

PERFORMANCE EVALUATION OF A THREE BOTTOM STANDARD DISC PLOUGH AT VARYING TILT AND DISC ANGLES

Olaniran, J.A.¹ and Babatunde, O.O.²

¹Department of Agricultural Engineering, LAUTECH, Ogbomoso, Nigeria.

²Department of Agricultural and Biosystems Engineering, University of Ilorin, Nigeria

Abstract

Ploughing which is the primary tillage operation aims at reducing the soil strength, cover plant residues, and rearrange soil aggregates. In this operation, considerable amount of farm tractor power is expended, and therefore efficient tillage system is desirable which minimizes the amount of energy required to till the soil. In this experiment, the combination of tilt and disc angle of a three bottom standard disc plough as they affect ploughing operation was studied in terms of width of cut, depth of cut, and volume of soil ploughed at a constant speed of 5.6km/hr. The test was carried out with five disc angles; 37°, 40°, 43°, 46° and 49°, in combination with five tilt angles; 15°, 20°, 22.5°, 25°, and 30° at constant ploughing length. The experiment was run at different passes of 3-blade combination maintained at 25 m ploughing length and data were taken at 5 m interval. The physicommechanical properties of the soil in the experimental plot were determined and found to be 6.7% soil moisture content (wb), bulk density is 1.53g/cm³, soil aggregate distribution of 7:1:2 (sand, silt and clay). The best performance of the three bottom standard disc plough was found at the combination of tilt angle in the range of 15°-25°, and 43°-46° disc angles. Ploughing below and beyond these values was not efficient.

Keywords: Ploughing, three-bottom standard disc plough, tillage, tilt angle, disc angle

1.0 INTRODUCTION

There are various agricultural activities involved in land cultivation to produce food and fibre for human consumption and raw material for industry. One of these activities is tillage operation after land clearing. Tillage is defined as mechanical manipulation / disturbance of soil in order to reduce the soil strength, cover weeds and plant residues, and thereby producing a favorable environment for plant growth.

The wish of farmer is to obtain efficient tillage operation with minimum use of tillage implement, and this has tasked agricultural engineers to be concerned with tillage equipment for many years to identify and qualify appropriately physical performance specifications for tillage tools. A tillage tool out of adjustment may require up to twice the power needed for efficient tillage operation and still do an unsatisfactory job. The method of operation, accuracy of adjustment, and condition of repair affect the amount of power required and the quality of tillage produced (Jacobs and Harrell, 1983).

Many researchers have made attempt to identify and suggest appropriate plough angles (disc and tilt) suitable for ploughing operation (Gulvin and Stone, 1977; Kepner et al., 1987; Panigraphi et al.,

1990; Sheruddin et al., 1992; Osadumi, 1991; Nakra, 1987; Jagdishwar, 2004; Imonigie, 2007).

Some robust successes have been achieved. Nakra (1987) examined the effect of disc angle in penetration and draught of disc plough, and reported that increase in disc angle and reduction in tilt angle improve penetration under hard soil conditions. He recommended a disc angle of 50° and 18° tilt angle for average ploughing conditions. Sheruddin et al (1992), concluded from a research work on different disc and tilt angle that;

- (i) At higher disc angles, the travel reduction increased and at higher tilt angles the travel reduction decreased.
- (ii) Field capacity was increased with an increase in disc and tilt angle.
- (iii) Fuel requirement were increased with an increase in disc and tilt angle. They however, recommended that further research work on disc and tilt angle could be carried out on other type of soil and using other simplified method. The objective of this study is to determine the combination of tilt and disc angles that will give the best performance of a disc plough

with respect to width and depth of cut on a particular soil type and condition.

1.1 Disc and Tilt Angle

Disc angle is an angle made between ‘line of travel’ of implement and the ‘axle line’ of each disc blade Fig. 1a, while the tilt angle is the amount of

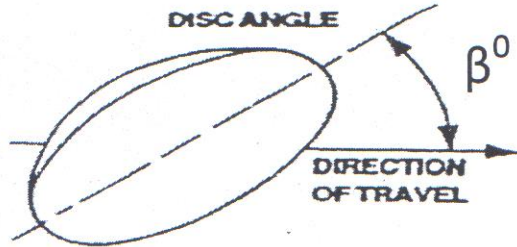

Fig. 1a: Disc Angle

inclination of the disc from the vertical position Fig. 1b. The size of these angles contribute greatly to affecting the performance of disc plough in terms of penetration into the soil, cutting through crop residues, inversion of soil, and draft of the implement.

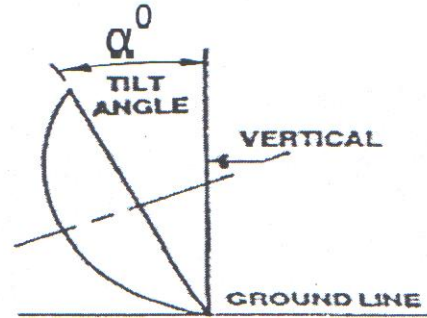

Fig. 1b: Tilt Angle

2.0 MATERIALS AND METHODS

An experimental plot of 1 hectare was selected at the Agricultural Engineering Research Plot, University of Ilorin, Nigeria. The plot has been cleared formerly for research work but overgrown with weeds, mostly spear grass and elephant grass. The random measurement of 25 selected grasses showed an average height of 1.25m. The site was carefully observed to ensure it is free of obstruction, as a guide against damage to the tractor and implement, and to facilitate smooth ploughing operation.

2.1 Physico-mechanical properties of the Soil

Different physico-mechanical properties of soil in the experimental plot were determined according to test code and procedure for ploughs in RNAM, (1983). Soil particle size analysis was determined to be 7:1:2 (sand, silt and clay) through sedimentation process using hydrometer. Penetrometer profile and cone index of the experimental plot both before and at ploughing depth were found with the relationship;

$$\text{Cone Index (C.I) (kg/cm}^2\text{)} = \text{load applied on penetrometer (kg)} \text{-----(1)}$$

Base area of the cone (cm²)

The soil moisture content and soil bulk density on wet basis were determined before ploughing operation using the relationship below, and the results is presented in Table 1 and 2.

Soil moisture content (S_{mc}) =

$$\frac{W_w - W_d}{W_w} \times 100\% \text{-----(2)}$$

Where;

S_{mc} = Soil Moisture Content %

W_w = Weight of Wet Soil Sample, (g)

W_d = Weight of Oven dried Soil Sample, (g)

Bulk density of the soil (B_{ds}) =

$$\frac{M}{V} \text{----- (3)}$$

Where;

M = Mass of the Soil Samples

V = Volume of the Core Sampler

2.2 Equipment and Implement

A mounted 3-bottom disc plough was used for this study as shown in fig.2. The plough has three discs with 61cm diameter each. The distance between the disc along the frame is 54cm. The implement has a vertical clearance of 64cm, and there is provision for tilt and disc angle adjustment. A Steyr 768 diesel tractor was used to power the implement at a constant speed of 5.6km/hr. Other equipment and tools used include; ASAE standard soil cone penetrometer, 100 m measuring tape, 1m steel metre rule, 2 m steel tape, try square, and combination set with spirit level.



Fig. 2: NARDI ITALIA 3-Bottom Standard Disc Plough

2.3 Disc Angle and Tilt Angle measurement and selection

2.3.1 Disc Angle

The five holes on the lower hitch bar of the plough in combination with three holes on the plate at the top of the frame gives an angular orientation of the disc to the tractor’s line of travel. Fifteen values of disc angles were determined at various combinations of 3 by 5 holes. Five of these values were then selected for the research work based on constant interval. They are; 37°, 40°, 43°, 46°, and 49°.

2.3.2 Tilt Angle

Five tilt angles; 15°, 20°, 22.5°, 25°, and 30° were determined through the angular displacement of the disc from the vertical through each of the holes on the plough bottom.

2.4 Experimental Procedure

The experiment was designed such that different settings and combination of disc and tilt angles were used. The experiment run at a time in a single pass of 3-blade combination maintained at 25m ploughing length. One operator was engaged for the experiment. The ploughing length was pegged at 5m interval to take five readings of depth and width of cut respectively per length.

3.0 RESULTS AND DISCUSSION

The average value of depth of cut and width of cut obtained at different combinations of tilt and disc angles are presented in Tables 3 and 4. The volume of soil ploughed was also calculated from average width and depth of cut, and the result is presented in Table 5.

Table 1: Determination of the Bulk Density of the Soil (Wet Basis)

	Samples		
	A	B	C
Length of Core Sampler (cm)	8.0	8.0	8.0
Diameter of Core Sampler(cm)	8.30	8.30	8.30
Weight of core sampler only (g)	280.0	279.0	280.0
Weight of Core sampler + soil Sample (g)	943.0	939.0	945.0
Weight of soil sample only (g)	663.0	660.0	665.0
Bulk density (wet basis) g/cm ³	1.53	1.52	1.54

$$\text{Average bulk density} = \frac{1.53 + 1.52 + 1.54}{3} = 1.53 \text{g/cm}^3$$

Table 2: Determination of Moisture Content of the Soil (Wet Basis)

	Samples		
	A	B	C
Weight of empty can (g)	27.0	28.0	27.0
Weight of empty can + wet soil sample (g)	73.0	71.0	72.0
Weight of wet soil sample only (g)	46.0	43.0	45.0
Weight of can + oven dried sample (g)	69.5	68.5	69.0
Weight of oven dried soil sample (g)	42.5	40.5	42.0
Moisture content in %	7.61	5.81	6.67

Average Moisture Content = 6.7% (wb)

Table 3: Average values obtained for depth of cut (cm) for combination of disc and tilt angles

		Depth of cut (cm) at different combinations				
Disc angle	↓	Tilt angles →				
		15°	20°	22.5°	25°	30°
37°	↓	23.4	23.5	25.0	25.1	21.9
40°	↓	24.1	24.7	26.0	26.6	23.5
43°	↓	27.3	26.3	26.6	23.6	22.1
46°	↓	25.7	26.2	27.7	23.9	22.8
49°	↓	23.3	23.7	26.4	27.0	21.9

Table 4: Average values obtained for width of cut (cm) for combination of disc and tilt angles

		Width of cut (cm) at different combinations				
Disc angle	↓	Tilt angles →				
		15°	20°	22.5°	25°	30°
37°	↓	43	51	52	53	45
40°	↓	53	54	44	58	48
43°	↓	56	58	60	58	49
46°	↓	61	61	62	63	59
49°	↓	59	57	54	56	43

Table 5: Volume of soil ploughed (cm³) for combination of disc and tilt angles

		Volume of soil ploughed (cm ³) at different combinations				
Disc angle	↓	Tilt angles →				
		15°	20°	22.5°	25°	30°
37°	↓	10	12	13	13	10
40°	↓	13	13	14	15	11
43°	↓	15	15	16	12	11
46°	↓	14	15	16	17	13
49°	↓	15	15	15	13	10

3.1 Depth of Cut (cm):

The 3-bottom disc plough made a poor depth of cut at 37° disc angle in combination with all the tilt angles except at 22.5° and 25° tilt angles (Table 3). The same trend could be observed at 40° disc angle which only made an improved width of cut

when it was combined with 22.5° and 25° tilt angles. However, the depth of cut increased sharply at 43° and 46° disc angle in combination with 15°, 20° and 22.5° tilt angles. Increased depth of cut is an indication that compacted layers of soil is broken up so that air, moisture and nutrients can reach the roots

of plant. It also encourages root development. Better depth of cut was also obtained at 49° disc angle in combination with 22.5° and 25° tilt angles (Table 3). It could however be noted from the table that ploughing at 30° tilt angle in combination with all the chosen disc angles (37°, 40°, 43°, 46°, and 49°) gave a poor depth of cut. This implies that disc angles 37°, 49° and 30° tilt angle may not be considered for a good ploughing operation.

3.2 Width of Cut (cm):

One of the objectives of ploughing operation is to cover and mix trash, incorporate organic matter and fertilizers into the soil. This enables the control of weeds and insects. In order to achieve this, ploughing operation should give a better width of cut. From Table 4, it could be observed that the combination of 43° and 46° disc angle with 15°, 20°, 22.5° and 25° tilt angle gave an improved width of cut. Particularly, 46° disc angle made better width of cut with all the tilt angles. The width of cut however dropped at 49° disc angle in combination with all the tilt angles especially at 30° tilt angle. It could be summarized from these observations that to achieve a good weed inversion and incorporation of organic matter/fertilizers, the choice of 46° disc angle and between 15°-25° tilt angle could be suitable to a greater extent.

3.3 Volume of Soil Ploughed

A greater volume of soil turned is an indication of good ploughing performance as this will ensure improved soil structure by rearranging the soil aggregates. A good soil structure has enough pore spaces for air and water to enter easily. It could be noticed from Table 5 that at lower tilt angle with increasing disc angle, the volume of soil turned increased. At disc angles of 37° and 40° the volume of soil turned is generally poor. The same poor trend is also observed at 30° tilt angle in combination with all the disc angles. Therefore, increased disc angle and decreased tilt angle would achieve large volume of soil to be turned thereby resulting in a good plough performance.

Conclusion

The results of the experiment indicated a better performance of the disc plough in the range of 15°-25° tilt angle, and 43°-46° disc angle.

Considering the conditions of the ploughed soil, it can be concluded that ploughing with 3-bottom standard disc plough at the combination of 25° tilt angle and 46° disc angle could be the best combination for ploughing operation. This observation agrees to a greater extent with recommended tilt and disc angles in the literature.

REFERENCES

- Gulvin, H.E, and Stone, A.A. (1977): Machine for Power Farming, 3rd Edition John Wiley and Sons Publishers, New York. Pp. 161-163.
- Imonigie, P.S. (2007): Basic Principles of Farm Mechanization and Machinery. Stirling – Horden Publishers (Nig.) Ltd, Orogun Ibadan, Nigeria.
- Jacobs, C.O. and Harrell, W.R. (1983): Agricultural Power and Machinery Mc Graw-Hill, Inc.
- Jagdishwar S. (2004): Element of Agricultural Engineering 4th Edition. Standard Publisher Distributors, New Delhi.
- Kepner, R.A, Bainer, R and Barger, E.L (1987): Principles of Farm Machinery 3rd Edition CBS Publishers and Distributions, New Delhi, Pp. 163-172.
- Oshadumi, J. (1991): An investigation on effects of tilt and disc angles on depth and width of cut of a disc plough. Unpublished B.Eng. Project Report, Agricultural Engineering Department, University of Ilorin, Nigeria.
- Panigraphi, B., Swain, S., and Mishra, J.N. (1990): Effect of implement and soil parameters on penetration depth of a disc plough. Agricultural Mechanization in Asia, Africa and Latin America vol. 21 (2). Pp. 9-12.
- RNAM Test Codes and Procedures for Farm Machinery, Technical Series No. 12 (1983): Regional Network for Agricultural Machinery Philippine.
- Sheruddin, B., Ghulam, R.M., Zafarullah, M., Panhwar., and Baloch, J.M. (1992): Effect of disc and tilt angle on field capacity and power requirements of mounted plough. Agricultural mechanization in Asia, Africa and Latin America 23(2). Pp. 9-13.