

## POWER FACTOR CORRECTION USING STATIC CAPACITOR: A CASE STUDY OF NIGERIAN 330KV GRID SYSTEM

<sup>1</sup>Adebayo, I.G. , <sup>2</sup>Olaomi A.A. <sup>3</sup>Akinkunmi, M. and <sup>4</sup>Olayonwa, Paul

<sup>1,2,3,4</sup>Department of Electronic and Electrical Engineering,  
Ladoke Akintola University of Technology, Ogbomoso.  
P.M.B. 4000, Ogbomoso, Nigeria.  
Correspondence: isaiahadebayo@yahoo.com

### ABSTRACT

*This paper work is concerned with the power factor correction using static capacitor being a case study of Nigerian 330kV Grid System. The research involves collection of various data relevant to the study from National Control Centre (NCC), Osogbo. The analysis is limited to the generator buses that have low power factors. Presented in this paper work is also the mathematical modeling of equations involving system monthly and annual savings. Simulations were done using MATLAB software package. The value of the static capacitor adopted and injected in each of the generator buses is 30kVar which is within the acceptable range of 25kVar to 40kVar. Where low power factors were noticed at the generator bus, static capacitor is injected to correct the low power factors especially at those buses. Typical examples are buses 2 (Jebba), 3 (Shiroro), 4 (Sapele), 5 (Delta) and 6 (Afam). The injection of static capacitor further leads to reduction in the load current in each of the generator buses and consequently, an increase in the system annual savings.*

**Keywords:** Power factor, Static capacitor, Generating station, MATLAB, Apparent power, Plant efficiency.

### INTRODUCTION

The electrical energy is almost exclusively generated, transmitted and distributed in the form of alternating current. Hence, the question of power factor immediately comes into mind. Most of the loads (e.g. induction motors, arc lamps) are inductive in nature and therefore, have low lagging power factor. Wasted energy capacity, also known as poor power factor, is often overlooked. It can result in poor reliability, safety problems and higher energy costs. Low power factor is also highly undesirable as it causes an increase in current, resulting in additional losses of active power in all the elements of power system from power station generator down to the utilization devices (Mehta and Mehta, 2005, Pamela, 2007).

The motors and other inductive equipment in a plant require two types of electric powers. One type is active power (i.e. working power) measured in kilowatt (kW). This is what actually powers the equipment and performs useful work. Another type is the magnetizing power which produces the flux necessary for the operation of inductive devices. The unit of measurement of magnetizing or reactive power is the kilovar (kVAR). The working power (kW) and reactive power (kVAR) together made up apparent power which is measured in kilovolt-

amperes (kVA) (Leon Wasser, 2009, Ray and Davis, 1988, Tse, 2003).

However, the power factor of a circuit is the ratio of active power to the apparent power.

$$\text{Power factor} = \frac{\text{Active power}}{\text{Apparent power}} = \frac{\text{kW}}{\text{kVA}} \quad (1)$$

In an inductive circuit, the current lags behind the voltage and the power factor is said to be lagging. However, in a capacitive circuit, current leads the voltage and power factor is leading.

In order to ensure most favorable conditions for a supply system from engineering and economic standpoint, it is important to have power factor as close to unity as possible.

### POWER FACTOR CORRECTION

The low power factor is majorly due to the fact that most of the power loads are inductive and therefore, take lagging currents. Low power factor results in unnecessarily high currents (requiring larger conductors and resulting in unnecessary losses). If a power source is required to deliver power (i.e. average power) to a load which has a low power factor ( $pf = \cos\theta$ ), the required current will be higher than it would be if the power factor were

larger. (Jason Starck, 2000). In order to correct the power factor, some devices taking leading power should be connected in parallel with the load (Mehta and Mehta, 2005). One of such devices is static capacitor (Hedin and Strump, 1981, Khoudiakev and Nivakin , 1981.). Other devices are synchronous motor, tuned harmonic filters and phase advancers. The capacitor draws a leading current and partly or completely neutralizes the lagging reactive component of load current. This raises the power factor of the load (Mehta and Mehta, 2005).

**ACTIVE, REACTIVE AND APPARENT POWER**

It is a known fact that reactive loads such as inductors and capacitors dissipate zero power. However, the fact that they drop voltage and draw current gives the deceptive impression that they actually dissipate power (Jim Lux, 2006). This power is called reactive power and it is measured in Volt-Amps-Reactive (VAR) or Kilovolt-Amps-Reactive (kVAR) rather than watts (W). The capital letter Q is the mathematical symbol for this reactive power (Theraja and Theraja, 1999).

However, the actual amount of power being used or dissipated in a circuit is the active power and it is measured in Watts (W) or kilowatts (kW). It is symbolized by the letter P. The combination of reactive power and active power is the apparent power and it is the product of a circuit’s voltage and current without reference to phase angle. Apparent power is measured in the unit of Volt-Amps (VA) or kilovolt-Amps (kVA) and it is symbolized by the capital letter S (Jim Lux, 2006).

As a rule, active power is a function of a circuit’s dissipative elements, usually resistances (R). Reactive power is a function of a circuit’s reactance (X). Apparent power is a function of circuit’s total impedance (Z). There are several power equations relating the three types of power to resistance, reactance and impedance (all using scalar quantities) (Jim Lux, 2006).

$$P = \text{Active power}, P = I^2 R, P = \frac{E^2}{R} \quad (2)$$

The unit of active power is W or kW.

$$Q = \text{Reactive power}, Q = I^2 X, Q = \frac{E^2}{X} \quad (3)$$

The unit of reactive power is VAR or kVAR.

$$S = \text{Apparent power}, S = I^2 Z, S = \frac{E^2}{Z} = IE \quad (4)$$

The unit of apparent power is VA or kVA.  
where

- P = Active power
- Q = Reactive power

- S = Apparent power
- I = Current
- R = Resistance
- X = Reactance
- Z = Impedance
- E = Voltage

**POWER FACTOR TRIANGLE**

Calculation of power factor correction can be illustrated from power triangle. In figure 1, the power triangle OAB is for the power factor  $\cos\theta_1$ , whereas power triangle OAC is for the improved power factor  $\cos\theta_2$ . It could be seen that real or active power (OA) does not change with power factor improvement. However, the lagging reactive power (kVAR) of the load is reduced by the power factor correction equipment. Therefore, the improved power factor is  $\cos\theta_2$

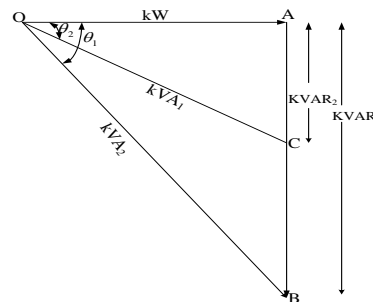

**Figure 1: Power Factor Correction**

**Triangle**

From figure 1, the leading kVAR supplied by the power factor correction equipment is

$$BC = AB - AC \quad (5)$$

$$= kVAR_1 - kVAR_2 \quad (6)$$

$$= OA(\tan \theta_1 - \tan \theta_2) \quad (7)$$

$$= kW(\tan \theta_1 - \tan \theta_2) \quad (8)$$

Knowing the leading kVAR supplied by the power factor correction equipment, the desired results can be obtained.

**Mathematical formulation of equations used in estimating annual savings for installing the power factor correction unit**

An inductive load taking a lagging current  $I$  and a power factor  $\cos\theta_1$  is considered. In order to improve the power factor of this circuit, the remedy is to connect the capacitor in parallel with the load

which takes a leading reactive component and partly cancels the lagging reactive component of the load.

$$kVar = S_1 \cos\theta_1 (\tan\theta_1 - \tan\theta_2) \quad (9)$$

$$\frac{kVar}{S_1 \cos\theta_1} = (\tan\theta_1 - \tan\theta_2) \quad (10)$$

$$\tan\theta_2 = \tan\theta_1 - \frac{kVar}{S_1 \cos\theta_1} \quad (11)$$

$$\theta_2 = \tan^{-1} \left[ \tan\theta_1 - \frac{kVar}{S_1 \cos\theta_1} \right] \quad (12)$$

$$\theta_2 = \tan^{-1} \left[ \tan(\cos^{-1} pf_1) - \frac{kVar}{S_1 \cos\theta_1} \right] \quad (13)$$

$$\cos\theta_2 = pf_2 \quad (14)$$

where

kVar = injected capacitor and is from 25kVar to 40kVar.

$S_1$  = uncorrected apparent power.

$\theta_1$  = lagging angle before capacitor is automatically injected.

$pf_1 = \cos\theta_1$  = uncorrected power factor.

Also,

$$P = S_1 \cos\theta_1 \quad (15)$$

kVA at uncorrected power factor =  $S_1$

kVA at corrected power factor =

$$S_2 = \frac{P}{\cos\theta_2} = \frac{P}{pf_2} \quad (16)$$

kVA nullified due to power factor correction =  $S_1 - S_2 = S_3$  (17)

Monthly savings =  $N332.10 \times S_3 = K$  (18)

Annual savings =  $12 \times K$  (19)

where,

P = active power

$\theta_1$  = lagging angle before capacitor is automatically injected.

$\theta_2$  = lagging angle after capacitor is automatically injected.

$S_1$  = uncorrected apparent power.

$S_2$  = corrected apparent power.

$S_3$  = nullified apparent power due to power factor correction.

K = monthly savings in naira

$pf_2 = \cos\theta_2$  = corrected power factor

N332.10 = the kVA rating for three phase commercial power consumption.

### Mathematical formulation of percentage reduction in current

$$P = S_1 \cos\theta_1$$

$$P = \sqrt{3} V I_1 \cos\theta_1 \quad (20)$$

$$I_1 = \frac{P}{\sqrt{3} V \cos\theta_1} \quad (21)$$

$$I_2 = \frac{P}{\sqrt{3} V \cos\theta_2} \quad (22)$$

$$\% \text{ Reduction in current} = \frac{(I_1 - I_2)}{I_1} \times 100 \quad (23)$$

where,

P = active power

$\theta_1$  = lagging angle before capacitor is automatically injected.

$\theta_2$  = lagging angle after capacitor is automatically injected.

$S_1$  = uncorrected apparent power.

V = 0.415kV = three phase voltage

$I_1$  = load current at uncorrected power factor

$I_2$  = expected load current at corrected power factor

## RESULTS AND DISCUSSION

### DATA COLLECTED FROM NATIONAL CONTROL CENTRE (NCC), OSOGBO

Table 1 shows the rated apparent power and their corresponding power factors for seven generating stations.

From Table 1, it is observed that five (5) generating stations (generator buses) have low power factors and hence, the need for improvement.

### THE RESULTS OF IMPROVED POWER FACTOR OF EACH GENERATING STATIONS

The results below were obtained after simulation with MATLAB software package. Table 2 shows the results of the apparent powers obtained with and without static capacitor, and the corresponding values of the power factors obtained when the capacitor was injected and when it was not.

**Table 1: Rated Apparent Power and Power Factor of Generating Stations (Base Case)**

S/N	GENERATING STATIONS	RATED APPARENT POWER (kVA)	POWER FACTOR
01	KAINJI	145.0000	0.9500
02	JEBBA	119.0000	0.8500
03	SHIRORO	176.5000	0.8500
04	EGBIN	276.9000	0.9000
05	SAPELE	110.0000	0.8000
06	DELTA	133.7500	0.8500
07	AFAM	110.0000	0.8000

**Table 2: Results obtained when static capacitor was injected compared with the Base case results**

S/N	Generating stations (Generator Buses)	Apparent power (KVA) Without Static capacitor	Apparent power (KVA) With Static capacitor	Power Factors (Without static capacitor)	Power Factors (With static capacitor)
01	JEBBA	119.0000	106.3004	0.8500	0.9515
02	SHIRORO	176.5000	162.7072	0.8500	0.9221
03	SAPELE	110.0000	95.0789	0.8000	0.9255
04	DELTA	133.7500	120.6716	0.8500	0.9421
05	AFAM	110.0000	95.0789	0.8000	0.9255

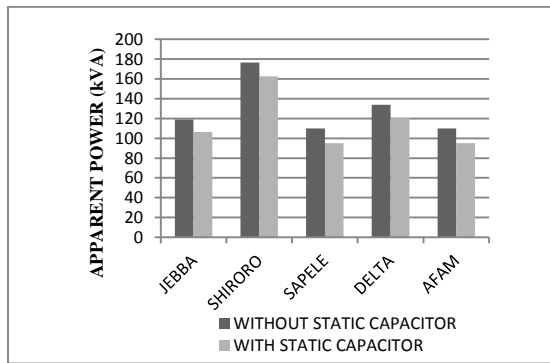

Figure 2: Comparism of Apparent Power with and without Static Capacitor

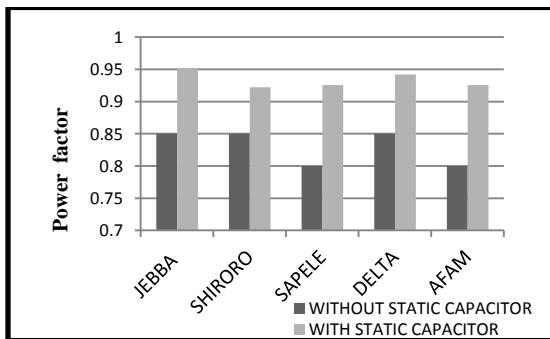

Figure 3: Comparism of power factor with and without Static capacitor

**THE RESULTS OF ANNUAL SAVINGS OF EACH GENERATING STATION**

Table 3 shows the monthly and annual savings of each generating station.

**Table 3: Monthly and Annual Savings of each Generating Station**

S/N	GENERATING STATIONS	MONTHLY SAVINGS (N)	ANNUAL SAVINGS (N)
01	JEBBA	4,218.00	50,611.00
02	SHIRORO	4,581.00	54,967.00
03	SAPELE	4,955.00	59,464.00
04	DELTA	4,343.00	52,120.00
05	AFAM	4,955.00	59,464.00

**THE RESULTS OF PERCENTAGE REDUCTION IN CURRENT OF EACH GENERATING STATIONS**

Table 4 shows the load currents at uncorrected power factors, the expected load currents at corrected power factors and the percentage reduction in current for each generating station.

**Table 4: Percentage Reduction in Current of each Generating Station**

S/N	GENERATING STATIONS	LOAD CURRENT AT UNCORRECTED POWER FACTOR (A)	LOAD CURRENT AT CORRECTED POWER FACTOR (A)	REDUCTION IN CURRENT (%)
01	JEBBA	165.5535	147.8857	10.6719
02	SHIRORO	245.5478	226.3591	7.8146
03	SAPELE	153.0326	132.2743	13.5646
04	DELTA	186.0737	167.8790	9.7783
05	AFAM	153.0326	132.2743	13.5646

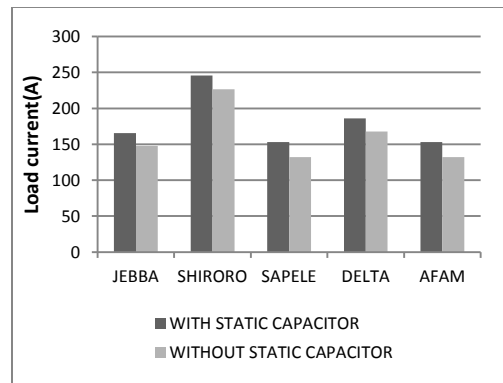

Figure 4: Comparism of load current with and without static capacitor

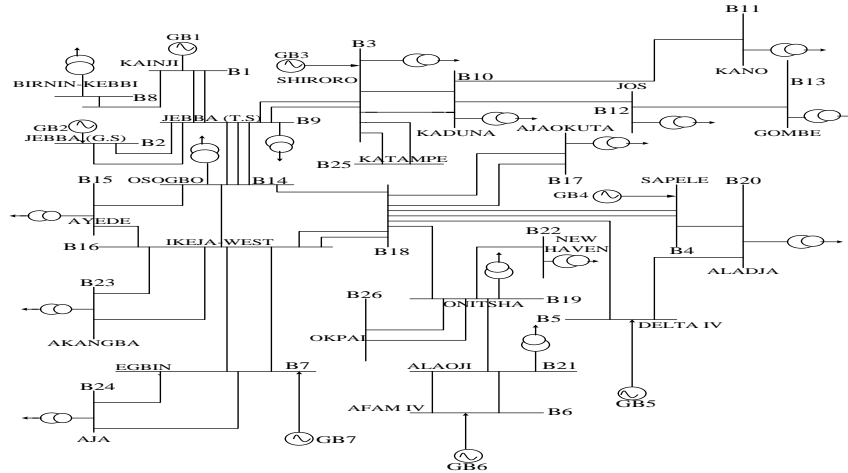

Figure 5: The single line diagram of the current 330kv Transmission Network

Source: (National Control Centre, Power Holding Company of Nigerian, Nigeria, 2007 )

### DISCUSSION OF RESULTS

Five generating stations (generator buses) were taken into consideration among other generating stations due to their low power factors. These include Jebba (0.85), Shiroro (0.85), Sapele (0.80), Delta (0.85) and Afam (0.80). Also, the range of injected capacitor which was used in this work is between 25kVar to 40kVar. The provision of automatic control for capacitors below 25kVar is not usually economical. In the course of this analysis, the value of injected capacitor used is 30kVar.

By comparing the uncorrected apparent power with the corrected ones as shown in figure 2, it is observed that the corrected apparent powers are lower than the uncorrected ones in each generating stations. Also, by comparing uncorrected power factors with the corrected ones as shown in figure 3, it is observed that power factors with static capacitor are higher than the uncorrected ones in each generating station. Moreover, by comparing the load currents at uncorrected power factors with the load currents at corrected power factors as shown in figure 4, it is observed that the load currents at corrected power factors are lower than the load currents at uncorrected power factors in each generating station. In addition, the annual savings of each generating station after power factor correction are of reasonable values.

### CONCLUSION

Power factor correction using static capacitor which is a case study of Nigerian 330kV grid system has been successfully carried out. The power factors of the generator buses considered that is, Shiroro (0.92),

Sapele (0.93), Afam (0.93), Delta (0.94) and Jebba (0.95) improved with the application of the static capacitor when compared with the initial values (base case) of those buses. Also, apparent powers are lower than the uncorrected ones. Both the apparent powers and power factors obtained in the course of reinforcing the system with static capacitor were used to calculate the annual savings of each generating station. Also, the load currents at corrected power factors are lower than the load currents at the uncorrected ones, specifically between 7-14% reduction in load current in each generating station. Hence, with the injection of static capacitor for power factor correction, the overall performance of the power system which can increase switchgear, starter, and motor life is improved. The bottom line of which is protection, efficiency, and maximum savings.

### REFERENCES

- Hedin R.A. and Strump K.B. (1981) "Series capacitor – a new scheme for damping subsynchronous resonance in compensated a.c. transmission system" Electric power research institute, USA, pubn 205, pp. 60.
- Jim Lux (2006), 'Lessons in Electric Circuit', HTML documents, vol. II, pp. 6- 21, Washington.
- Khoudiakev V.V. and Nivakin V. (1981) "Static compensators for power system and industries", All-union Electrotechnical Inst, USSR, Pubn 205, pp. 25.
- Leon Wasser (2009), 'Power Quality and Power Factor' Green Building Press, pp. 1-3.

- Mehta V.K. and Mehta R. (2005), 'A Textbook of principles of power system', First Multicolour Illustrative and Thoroughly Revised Edition, S. Chad and company Ltd., Ram Nagar, New Delhi-110055, pp. 100-117.
- Obais and Pasupuleti (2012). "Design of almost continuously controlled three-phase static VAR compensator for power factor correction purposes", vol.7 (2), pp.219-230. Available from: [ww.academicjournals.org/SRE](http://ww.academicjournals.org/SRE) [Accessed 9 March, 2012].
- Pamela, A. (2007) "Power Factor Correction for power systems" Department of Electrical and computer Engineering, Colorado state University, Fort collins, Colorado.
- Ray W. F. and Davis Rd. M. (1988) "The definition and importance of power factor for power electronics converters" Proc. European conference on Power Electronics and Applications (EPE) , pp. 799 – 805.
- Theraja B.L. and Theraja A.K. (1999) " A textbook of Electrical Technology" first edition, Chand S. and company Ltd. pp.433, New Delhi.
- Tony R.K. (2000), 'Power Factor Correction' HTML documents, vol. II pp. 6 – 21, Washington .
- Tse C. K. (2003). "International Journal of Circuit Theory and Applications", vol.31: pp.157-198.
- Available from: [www.Scirp.org/journal](http://www.Scirp.org/journal) [Accessed 9 March, 2012].