

OPTIMIZATION OF PROCESS PARAMETERS FOR NATURAL GAS SWEETENING USING ASPEN HYSYS AND RESPONSE SURFACE METHODOLOGY

Arinkoola A. Olatunde^{1,2,*}, Salam K. Kazeem¹, Jimoh M. Omolola¹ and Oghafua O. Nosa¹

¹Petroleum Engineering Unit, Department of Chemical Engineering, Ladoké Akintola University of Technology, Ogbomoso, Nigeria

²Petroleum Engineering Stream, African University of Science and Technology (AUST) Abuja, Nigeria

*Corresponding Author

Email: aoarinkoola@lautech.edu.ng

Abstract

Amines process remains the most economic and efficient technology available today for the removal of acid gases. However, the costs associated with pumping higher flow rates and cost of increased energy needs for the regeneration of solution can undermine the economic feasibility of the project portfolio. The absorber pressure, the composition and temperature at which the sour gas is available dictates sour gas and amine flow rates needed to meet the sweet gas specifications. To improve absorber capacity for a given sweet gas specification, optimization are commonly carried out using spread sheet with an adjust function to manipulate sour gas flow rate for fixed amine flow rate. This study performed optimization using response surface methodology on a simulated and calibrated amine plant. The result shows that the optimum operating conditions for 96% CO₂ removal were temperature of 30 °C, mass flow rate of 868.75 kg/hr and 20 numbers of plates. In conclusion, using experimental design and response surface methodology the parameter manipulation for attainment of optimal conditions is overcome.

1. Introduction

Hydrogen sulfide, carbon dioxide, water vapor and other sulfur containing compounds constitute major impurities in natural gas and pose serious operational challenges. The unique size of H₂S and CO₂ permits a perfect fitting into cavities formed by water molecules that result in gas hydrate formation under high pressures and relatively low temperatures (Paez et al. 2001). Natural gas that contains more than 5.7 milligrams of H₂S per one cubic meter of natural gas is “sour”. That containing only CO₂ and no sulfur compounds is termed “sweet” gas. However, it is a good practice to remove both impurities to prevent corrosion problems and increase the heating value of

concentration increases beyond 200 ppm, the sense of smell fatigues, and the gas can no longer be detected by odor. At 500 ppm, breathing problems have observed and death can be expected in minutes. At 1000 ppm, death occurs immediately (Arnold and Stewart, 1999).

Produced gases from reservoirs usually contain H₂S and CO₂ in varying concentrations ranging from barely detectable quantities to more than 3000 to 4000 ppm for H₂S and CO₂ respectively. From economic side, most contracts for the sale of natural gas require less than 4 ppm of these gases and heating value ranging from 920 to 980 Btu/scf (Mokhatab, 1999). Therefore, these impurities are

transported without al gas sweetening processes for the removal of CO₂ from natural gas. These include Chemisorption, Physical absorption, Adsorption, Hybrid solvents and Membrane separation (Kohl and Riesenfeld, 1997).

Notwithstanding, the design of the sweetening plant and the amount of solvent requirement are determined by the absorption behavior of the least soluble compound to be removed (Douglas et al., 1987). Process selection depends upon the pressure

and composition of the raw natural gas, the trace components and their composition, and the desired quality of marketable natural gas (pipeline specification of LNG). The chemisorption and physical absorption or combination of these two has been used extensively in existing LNG facilities (Jaswar Koto, 2014).

A typical LNG plant's overall flow diagram, and the main process units, is shown in Fig. 1. In this scheme, the feed gas is delivered at high pressure (up to 1,300 psi and 90 bar) from upstream gas fields via trunk lines and any associated condensate is removed. The gas is metered and pressure-controlled to the plant's design operating pressure.

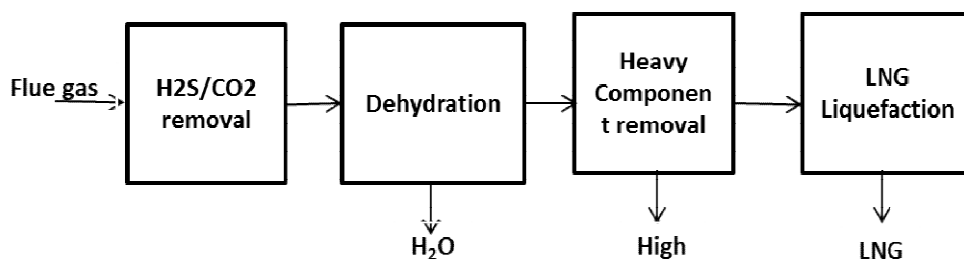

Figure 1: Typical LNG plant's block diagram

For optimum efficiency and effective impurity removal, the operating parameters of the sweetening unit must be maintained at optimum. Technically, when the gas reservoir pressure declines, the contracted gas flow rate decreases. Newwells are usually drilled to maintain production rate and front end compression may become necessary in the later stages of field life. But after a while when front end compression is also unable to supply gas with enough pressure, the pressure of the sweetening unit starts declining. Consequently, the efficiency of the unit keeps reducing with time.

In this paper the effect of declining pressure, number of plates and flow rate on the chemisorption processes are simulated using HYSYS. Usually, optimization are carried out using spread sheet with an adjust function to manipulate sour gas flow rate for fixed amine flow rate. Experimental design and response surface methodology were integrated with the numerical simulation for process optimization.

2 Theory

2.1 Chemisorption

Many solvent systems have been proposed and studied for removing CO₂ by chemical absorption. Mono Ethanol Amine (MEA) has been the most widely studied system (Alie et al., 2005, Abu-Zahra et al., 2007). The use of aqueous MEA for the removal of CO₂ from flue gases is a popular technology which has been described in detailed in a number of sources (Reddy et al., 2003, 2008). Other amines include tertiary amines such as Methyl Di

Ethanol Amine (MDEA) (Lu et al., 2005). Sterically hindered amines have also been investigated (Yih and Shen, 2002, Xu et al., 2002). The performance of hindered amines was found to be better suited to absorption in higher CO₂ partial pressure atmospheres (8-15% CO₂).

Mixed amine blends are designed to take advantage of the desirable properties in primary and tertiary amines. It is desired that these have the high capacity and low heat of absorption characteristic of tertiary amines and the fast rate of reaction characteristic of primary amines. This will lead to reduced circulation rates of the solvent and yield a lower heat duty in the stripper (Idem et al., 2006).

Irrespective of amine type, process selection depends upon the pressure and composition of the raw natural gas, the trace components and their composition, and the desired quality of marketable natural gas (pipeline specification of LNG specification). The design of the absorber and the amount of solvent required are determined by the absorption behavior of the least soluble compound to be removed (Wiley & Sons, 2007). In general, two reagents are available for chemisorption: the hot potassium carbonate solution and amines.

The hot potassium carbonate process is used to remove both CO₂ and H₂S in the gas stream. It works best on a gas with CO₂ partial pressures in the range of 30-90 psi (Kumar et al., 2003). Amines are well suited for applications where the acid gas partial pressures are low and low levels of acid gas are

desired in the residue gas. MEA,DEA and MDEA are extensively used in industry for CO₂ removal.

The flow scheme for all amine sweetening units is generally similar. MEA reacts with CO₂ and H₂S as follow (Kumar et al., 2003):

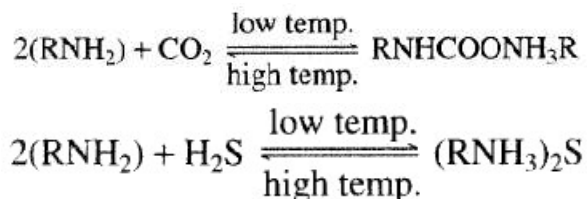

The fundamental underlying principle is the exothermic, reversible reaction between a weak acid (e.g., CO₂) and a weak base (e.g., amine) to form a

soluble salt. The choice of amine-concentration is often arbitrary and made on basis of experience. In general, corrosion inhibitors are effective in sweetening processes which allows the use of high concentration of amine. DEA concentration range is 30-40 wt. % but HYSYS can be applicable up to 50 %.

3 Methodology

3.1 Model specification and description

The flowsheet model from Abu-Zahra et al., (2007), was adopted for simulation and optimization of CO₂ removal (Figure 2).

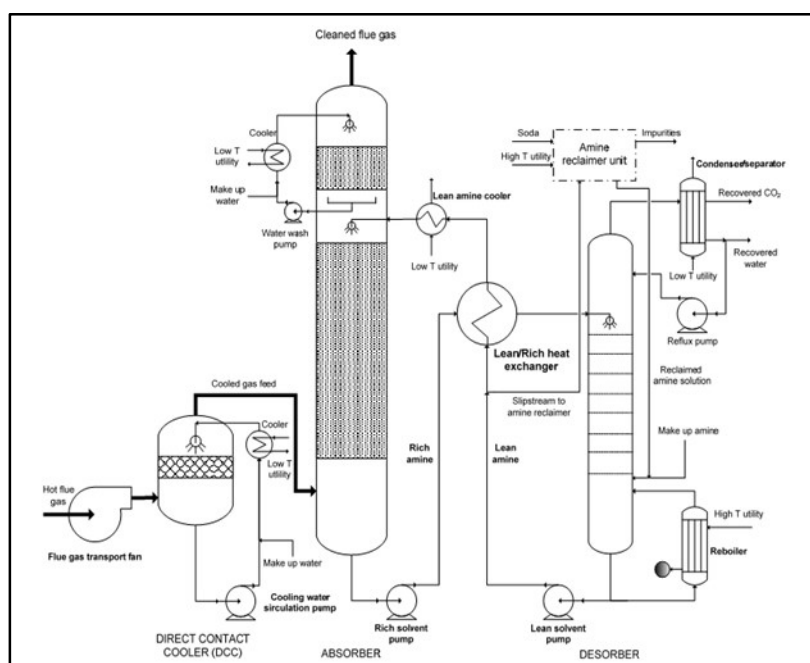

Figure 2: General flow diagram of a CO₂ removal process plant (Abu-Zahra et al., 2007)

The natural gas enters the plant through a knock-out vessel that removes any free liquid or entrainment solids. The gas leaves the top of the scrubber and enters the bottom of the absorber in countercurrent contact with aqueous lean amine solution. Sweet gas leaves the top of the absorber and flow to a dehydration unit before liquefaction. Lean amine flows downward to the sour gas and absorbs the CO₂ constituent and becomes rich solution. The rich solvent from the bottom of the absorber is flashed in a separator to recover some absorbed hydrocarbon in the rich solvent and then passed through amine-amine heat exchanger to the stripper where the acid gas

absorbed is stripped off at a very high temperature and low pressure. The acid gas then leaves the top of the stripper column. The lean amine from the bottom of the reboiler attached to the stripper flows through amine-amine heat exchanger and through a water air cooler before being introduced back to the top of the absorber.

These processes were modelled in the HYSYS simulation environment. Simulation was done using the in-built amine package with Kent Eisenberg's thermodynamic model for aqueous amine solutions and non-ideal vapor phase model. The components

and the fluid package are added. The un-simulated process flow diagram (PFD) developed is shown in

Figure 3.

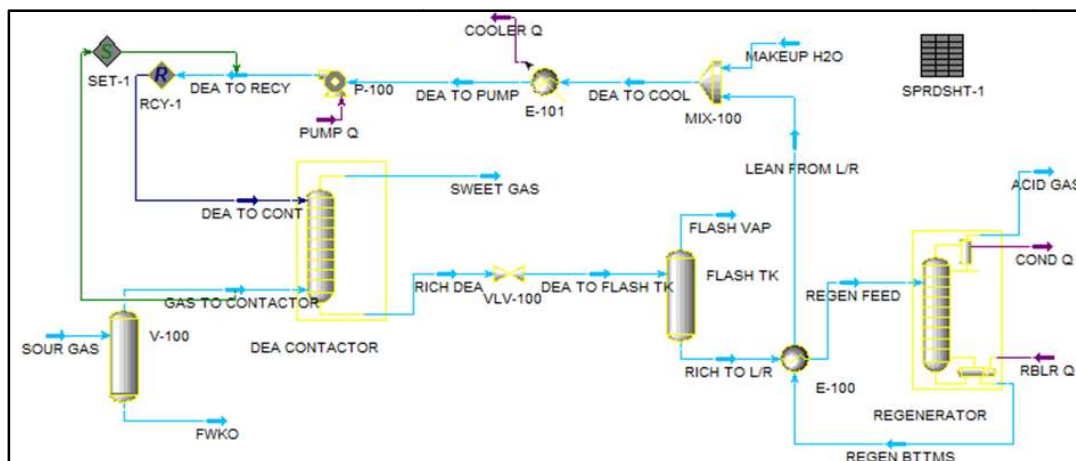

Figure 3: Un-simulated process flow diagram

3.2 Process Simulation

Table 1 shows the stream composition for HYSYS simulation. The simulation of the process begins with the simulation of the feed sour gas stream by specifying the gas temperature, pressure and flow rate. The natural gas enters the gas sweetening plant at temperature of 20 °C, pressure of 6895 kPa and with mass flow rate of 1100 kg mole/h. The remaining process parameters were estimated using EOS and the result is shown in Figure 4. Other streams specifications made are, the regenerated feed out of the amine-amine heat exchanger temperature to control the exchanger factor, DEA to Contactor temperature pressure and flow rate, make up water

temperature and DEA to recycle temperature. The material and energy balance is shown in Figures 5 and 6. Specification of sweet gas is around 50 ppm CO₂.

In order to ensure convergence on the absorber, the absorber top and bottom temperature and pressure was specified and simulated. Similarly, the regenerator convergence was attained by specifying the condenser and re-boiler pressure, the reflux ratio and the vent rate, the column was then simulated.

Table 1 Sour gas composition

Component	Molar Composition
Nitrogen	0.0016
Carbon Dioxide	0.0480
Hydrogen Sulphide	0.0171
Methane	0.8631
Ethane	0.0390
Propane	0.0092
i-Butane	0.0026
n-Butane	0.0029
i-Pentane	0.0014
n-Pentane	0.0012
n-Hexane	0.0018
n-Heptane	0.0071
Water	0.0050

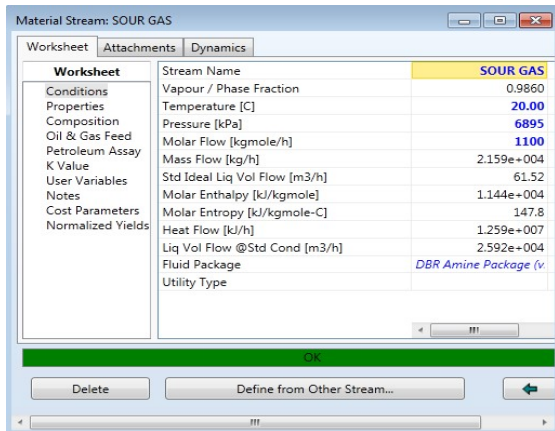

Figure 4: Natural gas property estimated at inlet conditions

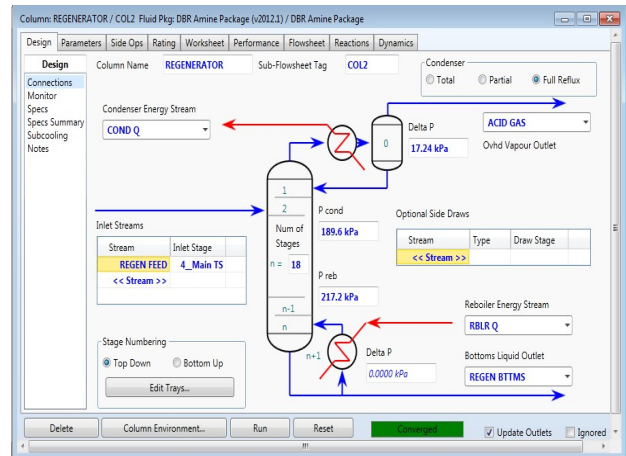

Figure 6: Converged regenerator

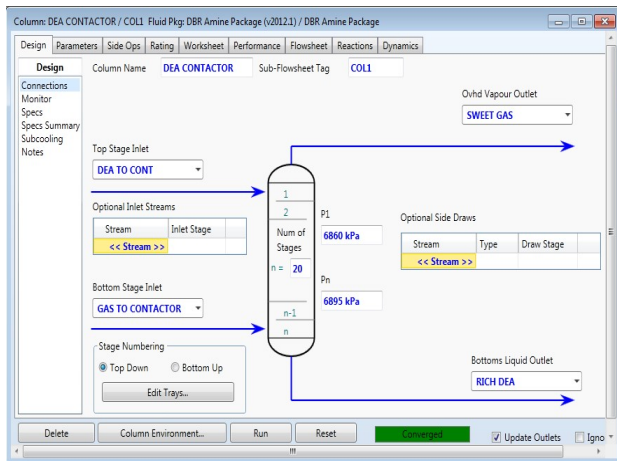

Figure 5: Converged absorber

Figure 7 shows a complete amine simulation for the base case parameters. The validity of the model was established by matching its performance with the historical data. An average absolute relative error less than 1.3% suggested that the model is representative and useful for optimization.

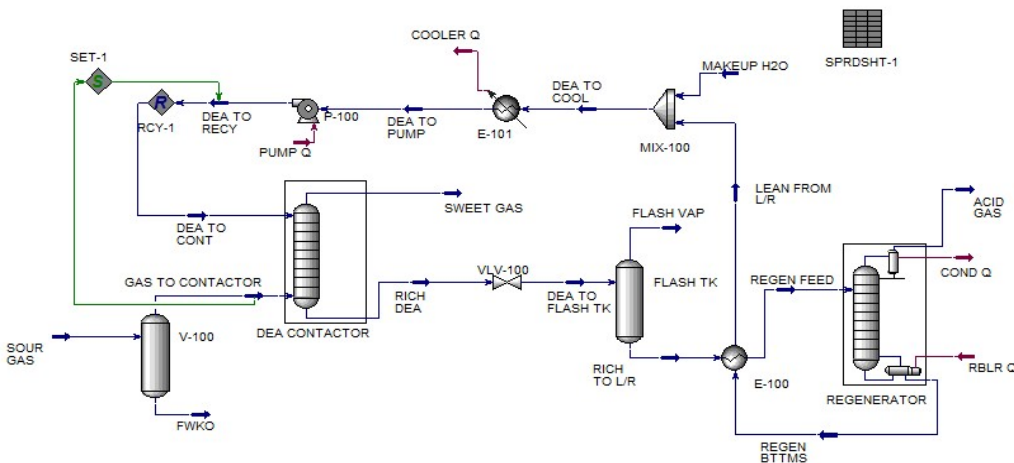

Figure 7: The complete simulation for base case Model

3.3 Sensitivity Analysis

Sensitivity analysis shows that the molar flow rate, temperature and number of plates are key process parameters. As shown in Figure 8 and 9, the temperature, number of plates and molar flow rate has a tremendous effect on amount of CO₂ removal. From Figure 8, it is observed that at constant molar

flow rate the removal efficiency increases with decreasing number of plates. For example, at 850 kg/h, maximum CO₂ remaining was recorded with minimum numbers of plates. The CO₂ removal decreases as the number of plate decreases until 15 plates. Similar observation was made for different temperature.

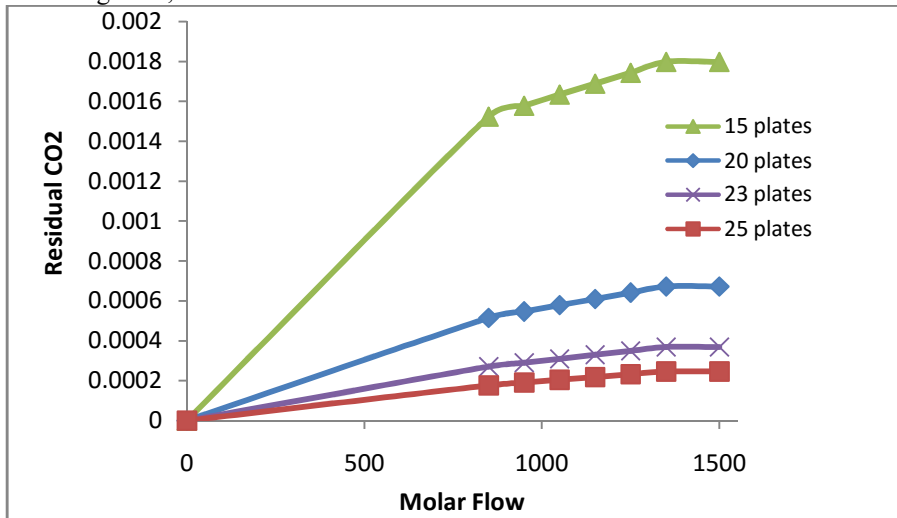

Figure 8 Sensitivity of CO₂ removals to molar flow rate for different number of plates at 20°C and 6898 kpa

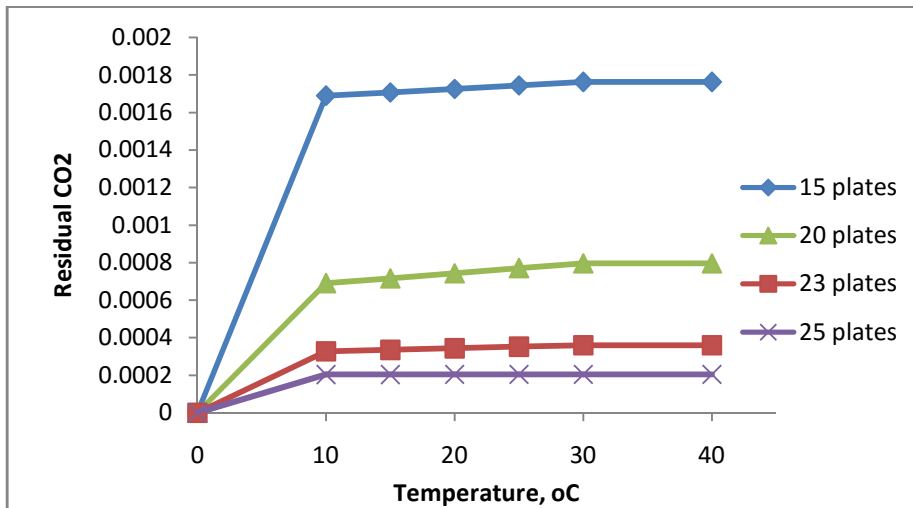

Figure 9 Sensitivity of CO₂ removals to molar flow rate for different number of plates at Molar flow rate of 1150 kg/h at different temperatures

3.4 Process Optimization

For optimization study, the parameters were sampled using Box-Behnken Design (BBD) algorithm. BBD belongs to the family of 3 level experimental design algorithms in which each numeric factor can be

varied over 3 levels. Table 2 shows the factors setting for experimentation. An overall of 17 experiments were performed as shown in Table 3. The result was analyzed by analysis of variance using response surface methodology (RSM).

Table 2 Parameter settings for optimization case

Name	Units	Low Actual	High Actual	Low Coded	High Coded
Temperature	oC	10	30	-1	1
Flow rate	kg/hr	850	1350	-1	1
Number of plate		15	25	-1	1

Table 3 Design Matrix for Box-Behnken Design

Std	Run	A:Temperature	B:q	C:NP	CO2 removal	
	5	1	-1	0	-1	0.046415
	10	2	0	1	-1	0.046075
	1	3	-1	-1	0	0.047474
	8	4	1	0	1	0.047812
	2	5	1	-1	0	0.047503
	11	6	0	-1	1	0.047825
	12	7	0	1	1	0.04769
	14	8	0	0	0	0.04747
	13	9	0	0	0	0.04747
	3	10	-1	1	0	0.047326
	17	11	0	0	0	0.04747
	9	12	0	-1	-1	0.046492
	4	13	1	1	0	0.047219
	7	14	-1	0	1	0.047813
	15	15	0	0	0	0.04747
	16	16	0	0	0	0.04747
	6	17	1	0	-1	0.038734

3.5 Response Surface Modelling

The development of valid response surface was based on careful analysis of variance for selection of model regressor and parameter interactions using value of "Prob > F" statistics. The F-statistics can be viewed as the ratio of signal (desirable) to noise (undesirable). The result obtained from the ANOVA is presented in Table 4. The Model F-value of

1208.55 implies the model is significant with high desirability. There is only a 0.01% chance that a "Model F-Value" this large could occur due to noise. It was observed that the probability coefficients (p-value) for T, Q, Np, Q², Np², T*Q, and Q*Np were less than 0.05, given a certainty level of 95%. This validate the choice of quadratic model consisted of main, quadratic terms for Q and Np as well as the interaction terms (T*Q and Q*Np).

Table 4 Analysis of variance

Source	Sum of Squares	DF	Mean Square	F Value	Prob > F	
Model	4.11E-06	7	5.87E-07	1208.55	< 0.0001	significant
T	9.63E-08	1	9.63E-08	198.37	< 0.0001	
Q	1.21E-07	1	1.21E-07	249.24	< 0.0001	
Np	3.29E-06	1	3.29E-06	6776.87	< 0.0001	
Q2	7.72E-08	1	7.72E-08	159.12	< 0.0001	
Np2	4.98E-07	1	4.98E-07	1025.61	< 0.0001	
T*Q	4.67E-09	1	4.67E-09	9.61	0.0147	
Q*Np	1.99E-08	1	1.99E-08	41.05	0.0002	
Residual	3.88E-09	8	4.85E-10			
Lack of Fit	3.88E-09	4	9.71E-10			
Pure Error	0	4	0			
Cor Total	4.11E-06	15				

3.6 Factors interaction

The ANOVA table shows clearly that all the selected main factors have significant effects on the CO₂ removal. The interaction of some of these factors exhibits significant effect on the model developed. Figure 9 and 10 are the 3-dimensional diagrams showing the main effects of flow rate, temperature, number of plates and their interaction on the CO₂ removal. A close observation of the base contour in these diagrams shows that main factors Q, T and Np independently have influence on the response setting a variable in its base value. For instance, as can be observed in

Figure 10, as the temperature increases from minimum to its maximum value, the amount of CO₂ removed was observed to increased. This observation is expected because transport of masses is enhanced at higher temperatures. Thus, temperature controls the transmissibility of mass and as such as

temperature increases, gas mobility increases so also the CO₂ removed. Keeping temperature constant at maximum value and increasing molar flow rate from minimum value to maximum, the amount of CO₂ removed increases untill around 1100 kg/hr when a further increase in flow rate resulted in a decrease in amount of CO₂ removed. There is therefore an optimality conditions for efficient absorption of CO₂ in the absorber.

Figure 11 shows the interaction of number of stages (Np) and amine flow rate (Q). The absorber number of stages have a dominat effect on the efficiency of the plant. For example, at low amine flow rate say 850 kg/hr, the amount of CO₂ removed increases with number of plates. Similarly, by setting the amine flow rate at its maximum value, the same observation was observed but with a corresponding lower efficiency. Thus it is desired to establish the optimum conditions for maximum removal of impurity from the natural gas.

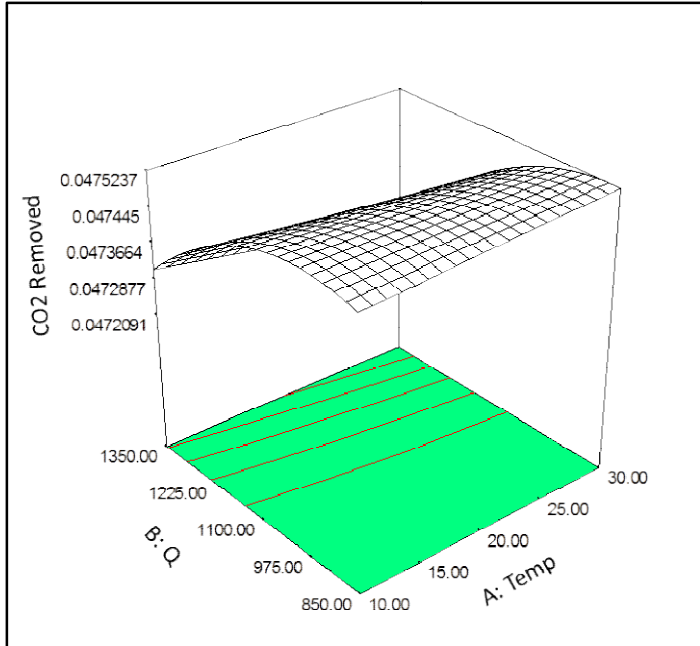

Figure 10 3-Dimensional diagram for the effect of mass flow rate (Q), temperature (T) and and their interaction on CO₂ removal.

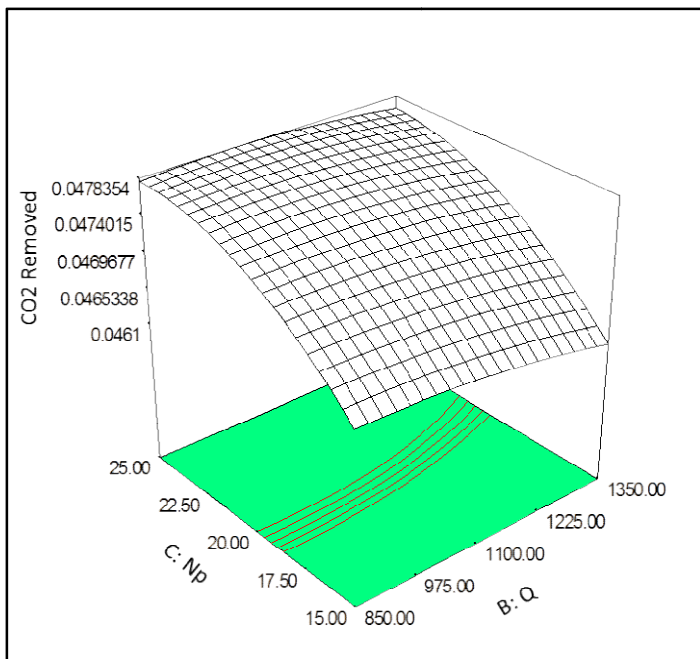

Figure 11 3-Dimensional diagram for the effect of mass flow rate (Q), number of plate (Np) and and their interaction on CO₂ removal.

To find the optimum process parameters that favor removal of CO₂ from the gas stream, an optimization problem was set up thus:

Maximize the objective function:

$$\begin{aligned}
 CO_2 \text{ removed} = & 0.038604 + 1.33647E - 05 * T \\
 & + 1.64146E - 06 * Q \\
 & + 6.66542E - 04 * N_p \\
 & - 1.35878E - 09 * Q^2 - 1.4594E \\
 & - 05 * N_p^2 - 1.366E - 08 * T * Q \\
 & + 5.646E - 08 * Q * N_p
 \end{aligned}$$

Subject to

$$10 \leq T \leq 30,$$

$$850 \leq Q \leq 1350$$

$$15 \leq N_p \leq 25$$

The standard deviation, multiple regression correlation coefficient, and predicted R-square values for the response surface model representing the objective function are 0.00002203, 0.9982 and 0.9911 respectively. The problem was solved numerically with the target criteria (CO₂ removed) set at maximum leaving the constraints at their ranges.

Figure 12 shows the ramp of numerical optimization in response surface methodology for temperature, mass flow rate and number of plate with CO₂ removed of 0.0475238 moles. Thus, the optimum operating conditions for column CO₂ removal were temperature of 30 °C, mass flow rate of 868.75 kg/hr and 20 numbers of plates.

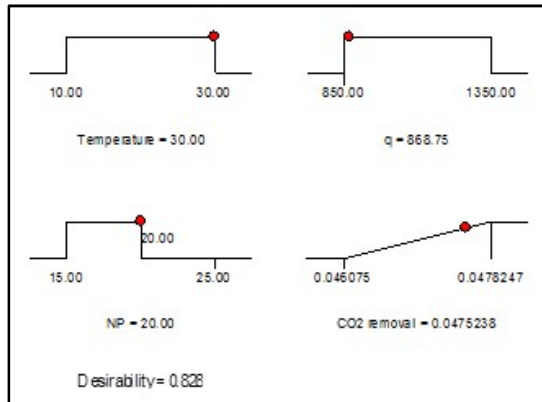

Figure 12 Ramp of numerical optimization in response surface methodology for Temperature, mass

flow rate and numbers of plates for CO₂ removal from a natural gas.

4 Conclusions and Recommendations

4.1 Conclusions

An optimization approach for CO₂ removal by integrating process simulator with the response surface methodologies is presented. The impacts of the amine flow rate, sour gas inlet temperature and absorber number of plates were analyzed. The results show that the number of absorber plates has a significant impact on the CO₂ removal. The efficiency was optimum as the number of plates reduces from 25 to around 20 for the selected solvent. The increase in amine circulation rate led to corresponding increase in amount of CO₂ removed. This could however increase the cost of the operation. The inlet temperature of the sour gas slightly affects the CO₂ removal. Thus, as the temperature decreases it is expected that the amount of energy requirement will tend to decrease.

4.2 Recommendations

Based on the experiment conducted, analyses and conclusions of this work, the following are recommended:

- (i). Detailed optimization framework for integrated equipment and process design parameters is recommended.
- (ii). The definition of the objective function in terms of cost is desirable. The use of Net Present Value (NPV) for example could give a more realistic analysis taking into account all the CAPEX and OPEX.

5.0 References

Paez, J.E., Blok, R., Vaziri, H. and Islam, M.R. (2001) 'Problems in gas hydrates: practical guidelines for field remediation', SPE paper No. 69424, SPE Latin American and Caribbean Petroleum Engineering Conference, 25–28 March, Buenos Aires, Argentina

Arnold, K. & Stewart M.; Surface Production Operations, Vol. 2; Ed. 2; Gulf Publishing Company; Houston TX; 1999; pp 151-153, 164-167,190.

Mokhatab R. Design Considerations for Acid Gas Injection. Laurence Reid Gas Conditioning Conference, 1999.

Douglas H. Mackenzie, Francis Chiraka Prambil, Christina A. Daniels, Jerry A. Bullin, (1987) "Design & Operation of a Selective Sweetening Plant Using MDEA," Energy Progress: 31-36

Kohl, A.L. and F.C. Riesenfeld, Gas Purification. 5th edition ed, ed. A.L. Kohl and F.C. Riesenfeld. 1997, New York: Elsevier. 1439.

Jaswar Koto (2014) "Absorption Acid Gas Removal in Liquefied Natural Gas Process," Journal of Ocean, Mechanical and Aerospace -Science and Engineering, Vol.7, pp24-28

Reddy, S., J. Scherffius, S. Freguia, and R. C., Fluor's Econamine FG PlusSM Technology: An Enhanced Amine-Based CO₂ Capture Process, in Second National Conference on Carbon Sequestration. 2003: Alexandria, VA.

Reddy, S., D. Johnson, and J. Gilmartin, Fluor's Econamine FG PlusSM Technology for CO₂ Capture at Coal-fired Power Plants, in Power Plant Air Pollutant Control "Mega" Symposium. 2008: Baltimore, MD.

Lu, J.G., L.J. Wang, X.Y. Sun, J.S. Li, and X.D. Liu, Absorption of CO₂ into aqueous solutions of methyldiethanolamine and activated methyldiethanolamine from a gas mixture in a hollow fiber contactor. Industrial & Engineering Chemistry Research, 2005. 44(24): p. 9230-9238.

Yih, S.M. and K.P. Shen, Kinetics of carbon dioxide reaction with sterically hindered 2-amino-2-methyl-1-propanol aqueous solutions. Industrial & Engineering Chemistry Research, 2002. 27(12): p. 2237-2241.

Xu, S., Y.-W. Wang, F.D. Otto, and A.E. Mather, Kinetics of the reaction of carbon dioxide with 2-amino-2-methyl-1-propanol solutions. Chemical Engineering Science, 1996. 51(6): p. 841-850.

Idem, R., M. Wilson, P. Tontiwachwuthikul, A. Chakma, A. Veawab, A. Aroonwilas, and D. Gelowitz, Pilot plant studies of the CO₂ capture performance of aqueous MEA and mixed MEA/MDEA solvents," Industrial & Engineering Chemistry Research, 2006. 45(8): p. 2414-2420

Wiley Critical Content-Petroleum Technology; Vol.1; John Wiley & Sons; 2007; pp-378

Kumar, P.S., J.A. Hogendoorn, G.F. Versteeg, and P.H.M. Feron, Kinetics of the reaction of CO₂ with aqueous potassium salt of taurine and glycine. Aiche Journal, 2003. 49(1): p. 203-213.

Abu-Zahra, M.R.M., L.H.J. Schneiders, J.P.M. Niederer, P.H.M. Feron, and G.F. Versteeg, CO₂ capture from power plants: Part I. A parametric study of the technical performance based on monoethanolamine. International Journal of Greenhouse Gas Control, 2007. 1(1): p. 37-46.

Alie, C., L. Backham, E. Croiset, and P.L. Douglas, Simulation of CO₂ capture using MEA scrubbing: a flowsheet decomposition method. Energy Conversion and Management, 2005. 46(3): p. 475-487.