

## DEVELOPMENT AND EVALUATION OF AN IMPROVED ELECTRO-MECHANICAL YAM POUNDING MACHINE

Oke M.O.<sup>1</sup>, Akinbode A.O.<sup>1</sup>, I.L. Sadiq<sup>1</sup>, K.A. Sulaiman<sup>1</sup>, S.A. Olaniyan<sup>1\*</sup> and J.B. Hussein<sup>2</sup>

<sup>1</sup>Department of Food Science and Engineering, Ladoke Akintola University of Technology, PMB 4000, Ogbomoso, Oyo State, Nigeria

<sup>2</sup>Department of Food Science and Technology, Modibbo Adama University of Technology Yola, PMB 2076 Yola, Adamawa State, Nigeria.

\*Corresponding Email Address: [saolaniyan18@lautech.edu.ng](mailto:saolaniyan18@lautech.edu.ng)

### ABSTRACT

*Yam is one of the oldest known recipes to man, which belongs to the class of carbohydrate and has been a part of the African meals for centuries. Pounded yam is generally accepted food prepared from yam tuber using indigenous method or equipment. Replacing such energy in cooking and yam pounding operation became expedient due to many reasons including tedious, laborious and very difficult. Materials to be used for construction of the electro-mechanical pounding machine were sourced locally and three different varieties of yam were used for its performance evaluation. It was observed from the result that the efficiency of the machine is high [98.75% (white yam), 99.70% (yellow yam), and 99.10% (water yam)]. The percentage lump and pounding capacity for white yam, yellow yam and water yam were 1.25, 3.49, 0.90 and 31.71, 29.68, 27.73g/s respectively.*

Keywords: yam, pounding, efficiency, percentage lump, pounding capacity.

### 1. INTRODUCTION

Yam, a tuber crop, which belongs to the class of carbohydrate type of food and has been one of the oldest recipes known to man. The world production of yam was estimated at 65.94 million metric tonnes in 2016. Out of this production, 93% came from West Africa, the main producers being Nigeria with 66.9% of world production; Ghana 11.3%; Côte d'Ivoire 9.0%; and Benin 4.6% (FAOSTAT, 2017). Yam is a perennial herbaceous vine crop with different species such as the white yam (*Dioscorea rotundata*), yellow yam (*Dioscorea cayenensis*), water yam (*Dioscorea alata*) and trifoliate yam (*Dioscorea dumetorum*) (Ayodeji and Abioye, 2011; Olaoye and Oyewole, 2012). Nutritionally, yam was analysed to have 80% starch, 7% protein, 1.7% lipid, 7% mineral, 3% fibre and 64% moisture content with 385Kcal energy from 100g of white yam (Olaoye and Oyewole, 2012). Yam was also observed to have lower Glycemic Index than potato tuber (Kay, 1987) and this attribute make yam provides a more sustained energy that protects the consumer against diabetes and obesity (Walsh, 2003). In the humid tropical countries of West Africa, yams are one of the most highly regarded food products and are closely integrated into the social, cultural, economic and religious aspects of life. Traditional ceremonies still accompany new yam production, indicating the high status given to the plant (FAO, 1998).

Yam can be changed from one form to another through various forms of processing e.g sliced yam that are sun-dried and milled into powder form is used to produce 'Amala' and eaten with choice soup. Yam can be cut into smaller sizes and fried in oil, small tubers of yam are roasted, and parboiled yam can also be turned into porridge and even pounded (Omotosho, 2011). All these are done to create varieties for human consumption. Pounded yam, which is one of the ways yam is utilized, is a generally accepted food in Nigeria (Ajibosin *et al.*, 2005). It is eaten by almost all the tribes in Nigeria and is highly regarded amongst all other foods. The traditional method of pounding yam is by pouring boiled yam into a wooden mortar and then pounded with a pestle. However, the use of wooden mortar and pestle was found to be tedious, time consuming, unhygienic and requires more labour which eventually adds to the cost of preparation (Ajibosin *et al.*, 2005). These shortcomings in its production necessitate for a less strenuous and cheaper method of making pounded yam (Otunola and Ogunbiyi, 2005).

Different methods of pounding yam have been reported by different researchers; (Makanjuola, 1975; Raji and Oriola, 2007; Odior and Orsarh, 2008; Ayodeji and Abioye, 2011; Olaoye and Oyewole, 2012), just to mention few names. Habart and Kenwood (1975) introduced a mixer which was used for pounding yam and mashing potatoes, but it faded

away because of its inefficiency. It was best used for mashing potatoes which was less viscous, sticky and starchy than yam. The preparation time of pounded yam using this machine was also a problem factor in that the machine has to be stopped intermittently and allowed to cool in order to avoid overheating. Also, another technique is the processing of yam into instant pounded yam flour, this method is still in existence but a lot of people do not like it because of several processing techniques the yam has undergone (Odior and Orsarh, 2008). More so, instant pounded yam flour does not have the same taste as the ancient pounded yam. Also, milling machines and blenders have been used to mill cooked yam but these methods are not also as effective as the use of mortar and pestle, milling machine do not give the desired ductile texture of pounded yam and blenders do not give uniform textures also. Therefore, this research will consider an electro-mechanical method. Electro-mechanical yam pounding machine is a portable machine used to produce pounded yam and to solve the problem of fatigue which results from manual pounding.

The need for the replacement of human energy with machine has been one of the driving forces behind development of technology right from onset. Due to the drudgery involved in pounding yam, the amount of time consumed, the risk of contamination of the pounded yam to dripping sweat and mucous from the body of the person doing the pounding in the traditional methods of pounding and the inadequacy of several other techniques to give the desired uniform ductile texture of the native pounded yam, and improved yam pounder is pertinent. The development of an improved mechanical yam pounder is the best way of replacing human power with mechanical power, at the same time achieving the desired texture of the pounded yam, saving time and energy.

The objective of this study is to design, construct an improved, reliable and efficient yam pounding machine that will be easy to operate and maintain and to evaluate the fabricated yam pounder with the use of white yam (*Dioscorea rotundata*), yellow yam (*Dioscorea cayenensis*), and water yam (*Dioscorea alata*).

## 2 MATERIALS AND METHODS

### 2.1 Selection of materials for construction of the machine

The following determinant factors and assumptions were taken into consideration when constructing the improved electro-mechanical yam pounding machine based on the procedures described by Oladeji (2012).

- (i) **Strength:** The strength of each component of the machine was considered while selecting the materials. The type of forces that will be encountered during the operation of the machine were put into consideration.
- (ii) **Machinability:** The materials used are easy to machine and form into the required shape and size.
- (iii) **Cost:** The cost of the machine designed was put into consideration because it can either make or mar the success of the product. It is of no use designing a machine that has no commercial value due to its exorbitant cost thus, the materials used are affordable.
- (iv) **Corrosion Resistance:** The materials used for fabrication are non-corrosive so as to prevent contamination and nontoxic to the food sample.
- (v) **Ease of Maintenance:** The materials used are easy to clean, maintain and replace if damaged. Stainless steel was used for both pounding chamber and mechanism which does not corrode upon washing.
- (vi) **Use of Standard Parts:** The use of standard parts was put into consideration so as to save a lot of time and enhance uniformity.
- (vii) **Availability:** The materials are readily available, easy to access and source locally.

### 2.2 Components of the Machine

The pounding machine is an arrangement of simple components (Figure 1) assembled together to achieve both boiling and pounding function (Figure 2). These components are as listed below:

#### 2.2.1 Boiling and Pounding Chamber

This is where the boiling and pounding action takes place. It is cylindrical and made of stainless steel of 300 mm diameter and 200 mm high.

#### 2.2.2 Pounding Mechanism

This is made up of stainless steel bar with two alternating hammer-like ends. It is located in the pounding chamber and it is the main component that pounds the yam.

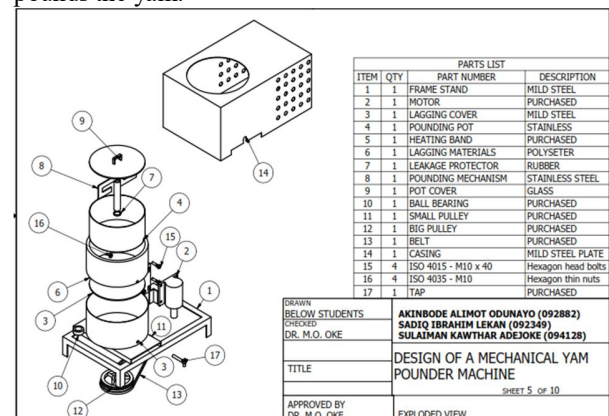

Figure 1: Exploded view of electro-mechanical yam pounding machine



Figure 2: Electro-Mechanical Yam Pounding Machine

### 2.2.3 Electric Motor

This provides power to the pounding machine by converting electrical energy into mechanical energy. An electric motor of 1 hp and 1440 rpm was chosen.

### 2.2.4 Transmission Belt

It is used to transmit power from the driver's pulley (pulley of the electric motor) to the driven pulley (pulley of the pounding mechanism).

### 2.2.5 Shaft

This was a stainless rod that transmits power from the driven pulley to the pounding mechanism. It was powered by an electric motor of 1hp through a belt and pulley arrangement.

### 2.2.6 Pulley

The machine has two pulleys, one on the shaft of the pounding mechanism and the other on the shaft of the electric motor. It transmits and receives power from the electric motor to the pounding mechanism respectively. The pulley on the mechanism shaft is bigger than that of the electric motor in the ratio 3 to 1. This is necessary to reduce the speed of the electric motor.

### 2.2.7 Bearing

Two ball bearings were used to help in holding the shaft of pounding mechanism in order to prevent abnormal rotation of the shaft.

### 2.2.8 Heating Band

The heating band provides the heat needed to cook the yam before pounding.

## 2.3 Design Specification

### 2.3.1 The Pounding Force and Power Requirement by the Electric Motor

The pounding force is the force required to masticate the boiled yam to fine desired texture.

Let the pounding force =  $P_F$

Then, the pounding pressure ( $P_p$ ) =  $\rho_b \times g \times h$  (1)

Where;  $\rho_b$  = density of boiled yam = 1950 kg/m<sup>3</sup> (Odior and Orsarh, 2008; Osueke, 2010)

$g$  = acceleration due to gravity = 9.81 m/s<sup>2</sup>

$h$  = height of the pounding mechanism = 0.075 m

$$(P_p) = 1950 \times 9.81 \times 0.075 =$$

$$1434.71 \text{ N/m}^2$$

Therefore, the pounding force ( $P_F$ ) =  $P_p \times A$  (2)

Where;  $A$  = the area covered by the mastication.

$$(P_F) = 1434.71 \times 0.0491 = 70.44 \text{ N}$$

The twisting effect of the pounding mechanism is given as;

$$\text{Torque } (T) =$$

$$P_F \times$$

distance of the beater from the line of action

$$(3)$$

$$T = 70.44 \times 0.125 = 8.80 \text{ Nm}$$

Then, the power required to operate the improved electro-mechanical yam pounding machine is given as;

$$\text{Power } (P) = T \times \text{Angler speed } (w)$$

$$(4)$$

$$\text{Where; } w = \frac{2\pi N}{60}$$

$$(5)$$

$$P = \frac{2\pi \times 480}{60} \times 8.80 = 442.3936 \text{ W}$$

Hence considering the factor of safety 1.5, the minimum power requirement for the design;

$$P = 442.3936 \times 1.5 = 663.59 \text{ W}$$

Therefore, based on the above calculations an electric motor of 1 hp with speed 1440 rpm, phase 3 and voltage of 440 V was chosen.

### 2.3.2 The Belt Drive Design

The belt drive is use to transmit power in the form of rotational motion to the pounding mechanism shaft. A V-belt was chosen for this design, since a high amount of power is to be transmitted from the pulley of the motor to the pulley of the pounding mechanism and the two pulleys are very close to each other, one side is slack and the other side tight. Also the wear taking place is visible and the belt can be change when they become old or break. Hence, this design was determine by the length of belt, wrap angles, belt tension and proper belt selection to transmit the required power.

The specification is as follows;

Diameter of small pulley (electric motor pulley),  $D_e = 50 \text{ mm}$

Since the ratio of transmission is 3:1,  
Diameter of the large pulley (pounding  
mechanism pulley) will be = 3 x De

$$= 3 \times 50 = 150 \text{ mm}$$

Speed of the electric motor pulley ( $N_e$ ) =  
1440 rpm

Speed of the pounding mechanism  
pulley  $N_b = \frac{N_e \times D_e}{D_b} = \frac{1440 \times 50}{150} = 480 \text{ rpm}$  (6)

The centre distance of the drive system;

$$x = D_e + 1.5D_b = 50 + (1.5 \times 150) = 275 \text{ mm}$$
 (7)

The angle of contact on the larger pulley  
(pounding mechanism pulley);

$$\theta_m = 180 + 2\alpha = 180 + 2(21.32) = 222.65^\circ = 222.65 \times \frac{\pi}{180} = 3.89 \text{ rad}$$
 (8)

Where;

$$\alpha = \sin^{-1} \left( \frac{D_b - D_e}{2x} \right) = \sin^{-1} \left( \frac{150 - 50}{2(275)} \right) = 21.32^\circ$$
 (9)

Mass of the belt per meter ( $m_b$ );

$$m_b = \frac{\text{weight of the belt per meter}}{\text{acceleration due to gravity}} = \frac{1.06}{9.81} = 0.108 \text{ kg/m}$$
 (10)

Where; weight of belt per meter = 1.06 N/m  
(Khurmi and Gupta, 2005)

Velocity of the belt ( $V_b$ );

$$V = \frac{\pi DN}{60} = \frac{\pi \times 0.150 \times 480}{60} = 3.77 \text{ ms}^{-1}$$
 (11)

Centrifugal tension ( $T_c$ );

$$T_c = m_b \times V_b^2 = 0.108 \times (3.77^2) = 1.54 \text{ N}$$
 (12)

Maximum tension on the belt ( $T$ );

$$T = \sigma \times \text{area} = 2.5 \times 10^6 \times 9.47 \times 10^{-5} = 236.84 \text{ N}$$
 (13)

Where;

Maximum allowable stress = 2.5 MPa  
(Khurmi and Gupta, 2005)

Density of the belt (rubber belt) = 1140  $\text{kgm}^{-3}$

$$\text{Area} = \frac{\text{mass of belt/metre}}{\text{density of belt}} = \frac{0.108}{1140} = 9.47 \times 10^{-5} \text{ m}^2$$
 (14)

Tension on the tight side ( $T_1$ );

$$T_1 = T - T_c = 236.84 - 1.54 = 235.30 \text{ N}$$
 (15)

Then tension on the slack sides of the belt  
shall be express as follows;

$$2.3 \log \frac{T_1}{T_2} = \mu \theta_m = 0.30 \times 3.89 = 1.167$$
 (16)

Coefficient of friction between rubber belt  
and dry pulley ( $\mu$ ) = 0.30 (Khurmi and Gupta, 2005).

$$\frac{T_1}{T_2} = \log^{-1} \left( \frac{1.167}{2.3} \right) = 1.38$$
 (17)

$$T_2 = \frac{T_1}{1.38} = \frac{235.30}{1.38} = 170.51 \text{ N}$$
 (18)

Power transmitted per belt;

$$P_b = (T_1 - T_2)v = (235.30 - 170.51) \times 3.77 = 244.26 \text{ W} = 0.24 \text{ KW}$$
 (19)

The pitch length of the belt;

$$L_p = \frac{\pi}{2} \times (D_e + D_b) + 2x + \frac{(D_e - D_b)^2}{4x} = \frac{\pi}{2} (50 + 150) + 2(275) + \frac{(50 - 150)^2}{4(275)} = 873.29 \text{ mm} \cong 870 \text{ mm}$$
 (20)

Therefore, a V-belt type A was selected for the design.

### 2.3.3 The Pot Capacity Design

The pot capacity was chosen based on the  
pounding mechanism size and the volume of the pot.  
The pounding mechanism diagram is shown in Figure  
3.

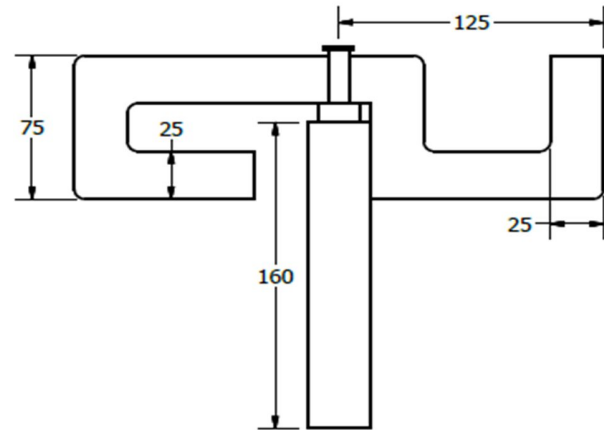

Figure 3: Pounding Mechanism

The pot diameter ( $D_p$ ) = 252 mm

The pot height ( $H_p$ ) = 75 mm

Therefore, the total volume of the pot

$$(V_p) = \frac{\pi D_p^2 H_p}{4}$$
 (21)

$$V_p = \frac{\pi \times 252^2 \times 75}{4} = 3741179.40 \text{ mm}^3$$

Volume of the pounding mechanism ( $V_m$ ) =  
1858500  $\text{mm}^3$

Therefore, the pot capacity that is the  
volume of pounded yam ( $V_y$ ) =  $V_p - V_m$  (22)

$$V_y = 3741179.40 - 1858500 = 1882679.40 \text{ mm}^3 = 0.001883 \text{ m}^3$$

Hence, the mass of yam tuber was calculated from;

$$\text{Density of yam tuber} = \frac{\text{mass of yam tuber}}{\text{volume of yam tuber}} \quad (23)$$

Where; density of yam tuber = 1250 kg/m<sup>3</sup> (Odior and Orsarh, 2008; Osueke, 2010)

Mass of yam tuber the machine can process at a time = 2.35 kg.

### 2.3.4 The Bearing Design and Selection

Since the loading of the machine is axial load and it is running at 480 rpm then a single row thrust bearing type was chosen. It dimensions is as follows (Khurmi and Gupta, 2005).

The dynamic equivalent radial load (W) for radial and angular contact bearing;

$$W = X.V.W_R + Y.W_A \quad (24)$$

Where, V = a rotating factor = 1.2 (for all bearings)

W<sub>R</sub> = radial load

W<sub>A</sub> = axial or thrust load

X = radial load factor = 1 (single row W<sub>A</sub>/W<sub>R</sub> ≤ 1.14)

Y = axial or thrust load factor = 0 (single row W<sub>A</sub>/W<sub>R</sub> ≤ 1.14)

$$W_R = P \times A = 1434.71 \times 4.9094 \times 10^{-4} = 0.70 \text{ N} \quad (25)$$

Where; P = the maximum pounding mechanism pressure

A = cross-sectional area of the pounding mechanism =  $\pi r^2 = 4.9094 \times 10^{-4} \text{ m}^2$

Therefore the dynamic equivalent radial load (W) for radial and angular contact bearing;

$$W = X.V.W_R + Y.W_A = 1 \times 1.2 \times 0.70 = 0.85 \text{ N}$$

The dynamic load rating for contact bearings under variable loads shall be express as follows;

$$C = W \left( \frac{L_{90}}{10^6} \right)^{1/K} \quad (26)$$

Where; C = basic dynamic load rating

L<sub>90</sub> = expected rating life at 90 % reliability (which ranges from 20000 to 50000 hours) (Khurmi and Gupta, 2005).

$$L_{90} = 60NL_H = 60 \times 480 \times 25000 = 720000000 \text{ revolutions}$$

L<sub>H</sub> = life in working hours

K = 3 (for ball bearings)

$$C = W \left( \frac{L_{90}}{10^6} \right)^{\frac{1}{K}} = 0.85 \left( \frac{720000000}{10^6} \right)^{\frac{1}{3}} = 7.62 \text{ N}$$

Therefore, the dynamic load for rolling contact bearing of 7.62 N corresponds to bearing designated 205 which translates into heavy duty

double roll angular contact bearing of bore diameter 25 mm. So this bearing shall be chosen;

Bore diameter = 25 mm

Outside diameter = 52 mm

Width = 15 mm

Then, the expected life of the selected bearing is;

$$L_{90} = \left( \frac{C}{W} \right)^K \times 10^6 = \left( \frac{7.62}{0.70} \right)^3 \times 10^6 = 1289.9438 \times 10^6 \text{ revolutions} \quad (27)$$

$$L_H = \left( \frac{L_{90}}{60 \times N} \right) = \left( \frac{1289.9438 \times 10^6}{60 \times 480} \right) = 44789.72 \cong 45000 \text{ hours} \quad (28)$$

### 2.3.5 The Heater Design

The total heat required, (Q<sub>T</sub>) is the energy required (excluding the wastage due to radiation/convection, etc.) for the cooking of yam tuber. Note, in this calculation, we have neglected the heat loss by air-convection/conduction and assumed that there was no heat loss from the bottom surface of the pot in contact with the heating element. The total heat required to cook yam was determined as described by (De et al., 2014).

Total heat required (Q<sub>T</sub>) = minimum or sensible heat required to cook yam (Q<sub>Y</sub>) + heat required to heat the pot (Q<sub>P</sub>) + latent heat of evaporation (L<sub>V</sub>) + Heat loss from the wall of the cooking pot (Q<sub>L</sub>).

#### 2.3.5.1 Sensible heat required to cook yam (Q<sub>Y</sub>)

$$Q_Y = m_y C_y (T_{mi} - T_a) \quad (29)$$

Where; m<sub>y</sub> = mass of yam

C<sub>y</sub> = specific heat capacity of yam = 2.056 kJ/kg°C (Oke et al., 2008)

T<sub>a</sub> = initial or ambient temperature of the pot

T<sub>i</sub> = inside wall temperature of the pot

T<sub>s</sub> = mean steam temperature

T<sub>mi</sub> = mean internal temperature =

$$\frac{T_i + T_s}{2}$$

#### 2.3.5.2 Heat required to heat the pot (Q<sub>P</sub>)

$$Q_P = m_p C_p (T_{mp} - T_a) \quad (30)$$

Where; m<sub>p</sub> = mass of yam

C<sub>p</sub> = specific heat capacity of pot = 502.416 J/kgK

T<sub>p</sub> = outside wall temperature of the pot

T<sub>mp</sub> = mean wall temperature of the pot =  $\frac{T_{mi} + T_p}{2}$

#### 2.3.5.3 Latent heat of evaporation (L<sub>V</sub>)

$$\text{Latent heat of evaporation} = \Delta m L_v \quad (31)$$

Where  $L_v$  = latent heat of vaporization ( $2.26 \times 10^6$  J/kg)

$m_f$  = mass of yam plus water and lid closed at the time  $t$  of cooking

$m_i$  = initial mass of yam plus water and lid closed at the time of putting on the heater

$\Delta m = (m_f - m_i)$  amount of water lost by evaporation.

### 2.3.5.4 Heat loss from the wall of the cooking pot ( $Q_L$ )

Heat loss from the wall of the cooking pot was determined as described by (Earle and Earle, 2004).

$$Q_L = h_c A_c (T_p - T_a)$$

(32)

Where  $h_c$  = the heat transfer coefficient at the outer surface

$A_c$  = curved surface area of the pot

Thus, the power required to power the heater of the improved electro-mechanical yam pounding machine was determined as described by (Hussein et al., 2017).

$$Power = \frac{total\ heat\ required}{time\ of\ pounding}$$

(33)

Based on the above calculations, a heating coil element of 1.5KW power was chosen for use.

### 2.3.6 The Frame/Case Design

The frame or casing is to cover the heating element and the pot, provides support as well serves as a house for the electric motor. It also serves as a holder to switches that control both the electric motor and the electric heater. It has two pins situated opposite of each other to hold the pot during cooking and pounding. The dimension of the frame base depends on the size of the pot and the electric heater selected while the electric motor determines the size of the upright and the overhead frame. The frame in which the electric motor was mounted are made with mild steel. Then the electric motor was booted and dampers attached to reduce vibration. To prevent corrosion of the frame, which may occur in the presence of air and water on metal, stainless steel was chosen for the top base and other parts are made from galvanized material.

## 2.4 Performance Evaluation

Three different species of yam tuber (white yam, water yam and yellow yam) were used to evaluate the machine. The yam tubers were manually peeled, sliced into small sizes, and weighed. The pieces of yam were neatly arranged into the stainless boiling chamber with water and the chamber cover

was replaced. The heating element was switched on for the pieces of yam to boil. Thereafter, heating element was switched off and the tap was turned on to drain excess cooking water. The masses were varied with time (1, 1.5 and 2 kg at 30, 45 and 60 seconds respectively). The pounder was switched on for the specified time, after which the pounder was switched off.

The pounded yam sample was packed into a clean bowl and examined to determine the mass of lumps present in it. This was then used to calculate the percentage efficiency of the pounding machine. The various weights of peeled yam, time taking and the resulting weight of well pounded yam were determined. The test was repeated for four times for each measured parameter and recorded. The pounding capacity as well as the percentage lumps were also determined using the following equations:

$$Pounding\ efficiency = \frac{mass\ of\ well\ pounded\ yam}{total\ final\ mass} \times 100\ %$$

(34)

$$Pounding\ capacity = \frac{weight\ of\ well\ pounded\ yam}{time\ taken\ for\ pounding}$$

(35)

$$Lump = \frac{mass\ of\ lump}{Total\ final\ mass} \times 100\ %$$

(36)

$$Total\ final\ mass = mass\ of\ well\ pounded + mass\ of\ lump$$

(37)

## 3. RESULTS AND DISCUSSION

The various weights of the three species of peeled yam tuber (white yam (*Dioscorea. rotundata*), yellow yam (*Dioscorea cayenensis*) and water yam (*Dioscorea alata*)), time taking for pounding and the resulting weight of well pounded yam were shown on the Tables 1, 2 and 3. The data generated for the calculated average value of pounding capacity, pounding efficiency and percentage lumps were also recorded. The average cooking time was also observed to be 25 minutes for the three species. Also for the three species it was observed that the machine took an average of 30 seconds to pound 1 kg of white yam, 45 seconds to pound 1.5 kg of yellow yam and 60 seconds to pound 2 kg of water yam.

It was observed from the result presented that the efficiency of the machine is high, the ability of the machine to pound effectively was higher for lower weight in the case of the water yam. For yellow yam the efficiency of 1 kg was lower than that of 1.5 kg and 2 kg (which are the same) and also, for white yam the efficiency of pounding 1.5 kg was higher than that of 2 kg while that of 1 kg was the lowest. The overall average efficiency of the machine is calculated to be 99.18%. The average pounding

efficiency (99.18%) of the fabricated machine is higher compared to that of Adebayo *et al.* (2014) who reported 93% pounding efficiency for a yam pounder cum boiler and 97% pounding efficiency for

traditional yam pounding method. Hitherto, Khalil (2014) reported 65% pounding efficiency for a machine that pound 0.36 kg yam within 55 seconds.

**Table 1: Evaluation of pounded yam produced from white yam**

Weight of peeled yam (g)	Weight of well pounded yam (g)	Weight of lumps (g)	Total final weight (g)	Pounding time (s)	Percentage lumps	Efficiency (%)	Pounding capacity (g/s)
1000	950	17.5	967.5	30	1.81	98.19	31.67
1500	1430	8.2	1438.2	45	0.57	99.43	31.78
2000	1900	26.6	1926.6	60	1.38	98.62	31.67

**Table 2: Evaluation of pounded yam produced from yellow yam**

Weight of peeled yam (g)	Weight of well pounded yam (g)	Weight of lumps (g)	Total final weight (g)	Pounding time (s)	Percentage lumps	Efficiency (%)	Pounding capacity (g/s)
1000	850	4.5	854.5	30	4.50	99.5	28.33
1500	1420	2.78	1422.78	45	2.78	99.8	31.55
2000	1750	3.25	1753.25	60	3.20	99.8	29.17

**Table 3: Evaluation of pounded yam produced from water yam**

Weight of peeled yam (g)	Weight of well pounded yam (g)	Weight of lumps (g)	Total final weight (g)	Pounding time (s)	Percentage lumps	Efficiency (%)	Pounding capacity (g/s)
1000	850	4.70	854.70	30	0.5	99.5	28.3
1500	1200	7.15	1207.15	45	0.6	99.4	26.6
2000	1700	28.40	1728.40	60	1.6	98.4	28.3

The average volume of yam pounded at a time with pounding capacity of the machine shows that the electro-mechanical yam pounder is approximately enough to feed two or more people. The pounded yam was equally good as the traditional pounded method with the added advantages of less processing time and high level of hygiene. The solution to indigenous needs through appropriate

technology was successfully represented in this work. The machine was developed from locally available materials which are quite affordable and available.

#### 4. CONCLUSION

The design and fabrication of the mechanical yam pounder with cooking that is easy to operate and maintain was undertaken. The general objective was achieved following the laid out

procedures while the stress and fatigue of manual pounding was eliminated. The machine was evaluated using white yam, yellow yam and water yam. The improved electro-mechanical yam pounder with the boiler unit was electrically operated, cook and pound pieces with rotary beater mechanism. The machine was able to boil and pounded the yam pieces hygienically. During performance testing, the yam pounding machine crushes the yam giving an average efficiency, lump percentage and pounding capacity of 98.75%, 99.70% and 99.10%; 1.25, 3.49 and 0.90; 31.71, 29.68 and 27.73 for white yam, yellow yam and water yam, respectively at minimum cooking time of 25 minutes.

Conclusively, the following recommendations were made; a better method of draining water after cooking should be devised, clamps should be made on the cover to prevent it from flying off during pounding, there may need to increase the pounding capacity of the machine to minimum of 3 kg at a time by increasing the capacity of the electric motor. There should be consideration for easy and hygienic sanitation of the chamber before and after pounding operation.

#### REFERENCES

- Adebayo, A.A., Yusuf, K.A. and Oladipo, A. (2014). Fabrication and Performance Evaluation of a Yam Pounder Cum Boiler. *Scientia Agriculturae*, 8(3), 112-120.
- Ajibosin, I.O., Daoudu, M.A., Omotade, S.A. and Komolafe, A.O. (2005). Capacity Building for Instant Pounded Yam Flour Production. *Nigerian Journal of Information Studies*, 4(4), 1-5.
- Ayodeji, S.P. and Abioye, T.E. (2011). Development and Performance Evaluation of a Parboiling Machine for Pounded-Yam Flour Processing Plant. *Journal of Emerging Trends in Engineering and Applied Sciences (JETEAS)*, 2(5), 853 – 857.
- De, D.K., Nathaniel, M., De, N.N. and Ikechukwu, M.A. (2014). Cooking Rice with Minimum Energy. *Journal of Renewable and Sustainable Energy*, 6(013138) (2014). doi:10.1063/1.4865794
- Earle, R.L. and Earle, M.D. (2004). *Unit Operations in Food Processing* ( Web Edition, 2004 ed.): The New Zealand Institute of Food Science & Technology (Inc.).
- FAO. (1998). *Storage and Processing of Roots and Tubers in the Tropics*. Retrieved from Food and Agriculture Organization of the United Nations:
- FAOSTAT. (2017). Global Yam Production in 2016. Available from FAO Retrieved February 28, 2018 from Food and Agriculture Organization of the United Nations
- Habart and Kenwood. (1975). Power Splitters. *Patent and Design Journal*, No. 6159, 522.
- Hussein, J.B., Hassan, M.A., Kareem, S.A. and Filli, K.B. (2017). Design, Construction and Testing of a Hybrid Photovoltaic (PV) Solar Dryer. *International Journal of Engineering Research and Science*, 3(5), 1-14.
- Kay, D.E. (1987). *Root Crops*. London: Tropical Development and Research Institute.
- Khurmi, R.S. and Gupta, J.K. (2005). *A Textbook of Machine Design* (Fourteenth ed.). Ram Nagar, New Delhi-110 055: Eurasia Publishing House (Pvt.) Ltd. .
- Makanjuola, G.A. (1975). The Design, Development and Testing of A Machine for Preparing Pounded Yam and Similar Foods. *Journal of Appropriate Technology, Intermediate Technology Publications*, 1(4), 9-10.
- Odiar, A.O. and Orsarh, E.S. (2008). Design and Construction of a Yam Pounding Machine. *International Journal of Nature and Applied Sciences*, 4(3), 319-323.
- Oke, M.O., Awonorin, S.O., Oyelade, O.J., Olajide, J.O., Ogunlakin, G.O. and Sobukola, P.O. (2008). Some Thermo-physical Properties of Yam Cuts of Two Geometries. *Agricultural Engineering International: CIGR Journal*, 5, 1-9.
- Oladeji, J.T. (2012). *Fundamentals of Machine Design*. Ibadan: Graceful Heights Prints
- Olaoye, J.O. and Oyewole, S.N. (2012). Optimization of some “Pounded” Yam Production Parameters. *Agricultural Engineering International: CIGR Journal*, 14(2), 1 – 15.



- Omotosho, O.K. (2011). *Design and Construction of A Yam Pounding Machine*. (Unpublished Thesis), University of Ilorin.
- Osueke, C.O. (2010). Design and Construction of a Yam Pounding Machine. Retrieved 05/11/2018, from Technological Research
- Otunola, E.T. and Ogunbiyi, R.S. (2005). Preliminary Studies on the Microbiological and Physico-chemical Characteristics of Fermented Pounded Yam. *Journal of Nutrition and Food Sciences*, 35(3), 135-142.
- Raji, A.O. and Oriola, K.O. (2007). Development of a Yam Pounding Machine. *Agricultural Mechanization in Asia, Africa and Latin America*, 38(4), 78-92.
- Walsh, S. (2003). *Plant Based Nutrition and Health*.