

12-30-2003

# Final Report: An Assessment to Determine the Most Suitable Location and Design for the Development of a City-run, Boat Sewage Pumpout Facility to Service Commercial and Recreational Vessels that Utilize the Waters within the Jurisdiction of the City of Boston

Urban Harbors Institute, University of Massachusetts Boston

Follow this and additional works at: [http://scholarworks.umb.edu/uhi\\_pubs](http://scholarworks.umb.edu/uhi_pubs)

 Part of the [Environmental Health and Protection Commons](#), and the [Water Resource Management Commons](#)

---

## Recommended Citation

Urban Harbors Institute, University of Massachusetts Boston, "Final Report: An Assessment to Determine the Most Suitable Location and Design for the Development of a City-run, Boat Sewage Pumpout Facility to Service Commercial and Recreational Vessels that Utilize the Waters within the Jurisdiction of the City of Boston" (2003). *Urban Harbors Institute Publications*. Paper 21.  
[http://scholarworks.umb.edu/uhi\\_pubs/21](http://scholarworks.umb.edu/uhi_pubs/21)

This Research Report is brought to you for free and open access by the Urban Harbors Institute at ScholarWorks at UMass Boston. It has been accepted for inclusion in Urban Harbors Institute Publications by an authorized administrator of ScholarWorks at UMass Boston. For more information, please contact [library.uasc@umb.edu](mailto:library.uasc@umb.edu).

---

# FINAL REPORT

---

***AN ASSESSMENT TO DETERMINE THE MOST SUITABLE LOCATION  
AND DESIGN FOR THE DEVELOPMENT OF A CITY-RUN, BOAT  
SEWAGE PUMPOUT FACILITY TO SERVICE COMMERCIAL AND  
RECREATIONAL VESSELS THAT UTILIZE THE WATERS WITHIN THE  
JURISDICTION OF THE CITY OF BOSTON***



Funded by the  
***Coastal Pollution Remediation “Plus” Program – FY ‘03***

Prepared by the  
**Urban Harbors Institute**  
University of Massachusetts Boston

Submitted by the  
**City of Boston Environment Department**  
Boston City Hall  
Boston MA 02201

*30 December 2003*

## TABLE OF CONTENTS

### List of Figures and Tables

Executive Summary	1
Sewage from Vessels — An Overview	3
The Need for Vessel Pumpout	4
Existing Vessel Pumpouts	5
Properties Considered	6
<b><i>Mystic Marine Fuel</i></b>	<b>9</b>
<b><i>Boston Towing and Transportation</i></b>	<b>10</b>
<b><i>Charlestown Pier 4</i></b>	<b>11</b>
<b><i>Black Falcon Cruise Terminal</i></b>	<b>11</b>
Description of Criteria Used	13
Required Permits	18
General Design and Equipment Requirements for Pumpout Facilities	20
Design and Equipment Requirements for the Selected Sites	24
<b><i>Specifics of Wet-well / Catch Basin Pumps</i></b>	<b>24</b>
<i>Types of Sewage Pumps</i>	25
<b><i>Specifics of Shoreside Pumpout Units</i></b>	<b>26</b>
Preliminary Cost Estimates for the Development of the Two Selected Sites	29
Operation and Maintenance	31
Preliminary Site Plans for the Two Selected Sites	32
Appendix 1: Specifications of ABS Pumps	34
Appendix 2: Specifications of Edson Pumpout Systems	45
Appendix 3: 1934 License for 400 Border Street Property	56

## LIST OF FIGURES AND TABLES

TABLE 1	Vessel sewage pumpouts in Boston Harbor	5
FIGURE 1	Water-dependent uses in the City of Boston	7
FIGURE 2	Summary of land use along City of Boston's shoreline	8
FIGURE 3	Color orthophotograph showing the location of the four sites that were assessed for this study	12
FIGURE 4	The approximate distances of locations within Boston Harbor from the two proposed commercial pumpout sites	15
TABLE 2	Criteria for commercial pumpout sites along Boston's Coastal waterfront	16
TABLE 3	Summary of permit requirements for commercial pumpout	18
TABLE 4	Estimated graywater and black water produced by cruise ships of various sizes	21
TABLE 5	Estimated graywater and black water produced by ferries of various sizes	21
FIGURE 5	The differences between pumpout systems that cater to vessels that do not have onboard sewage pumps and those that do	22
FIGURE 6	A typical shoreside manifold to which a large commercial vessel would connect its discharge hose and pump its effluent directly up and into a sewer line	23
FIGURE 7	ABS sewage pumps	26
FIGURE 8	Edson pumpout systems	27
FIGURE 9	Diagram describing how the static suction lift and the static discharge head relate to the function of a pump	28
TABLE 6	Estimated costs of equipment and installation at the two selected sites	30
	Preliminary site plan for Mystic Marine	32
	Preliminary site plan for 400 Border Street	33

## EXECUTIVE SUMMARY

This report presents the findings of a site and equipment feasibility study, as well as, a permit overview for the installation of a vessel sewage pumpout system for servicing commercial and recreational vessels in the City of Boston. As part of the analysis, we reviewed a number of sites located within the City of Boston's jurisdiction in Boston Harbor. We contacted facilities that have made recent investments in commercial grade pumpouts to learn more about the available technology. In analyzing the permit process, we reviewed local zoning requirements and had conversations with relevant City and state officials.

The project, as currently conceived, is to install a vessel sewage pumpout in Boston's Inner Harbor. As some commercial vessels have onboard sewage pumps while others do not, it is envisaged that the pumpout would need to be able to cater to both types of vessels. To this end, it would require a direct sewer line hook-up for those vessels equipped with onboard pumps, as well as a shoreside pumpout for the other vessels. Such a system would also be able to service recreational vessels. The pumpout must be conveniently located for commercial vessel traffic and it must have the power, capacity and adaptability to serve a varied fleet of boats. The pumpout would be connected directly to the municipal sewer system and ideally the necessary sewer infrastructure would already be in place.

### **Conclusions**

- At present, there are insufficient pumpout facilities to service the local and transient commercial vessels that operate in the waters of the City of Boston.
- Many commercial vessels operate inshore and can therefore only legally empty their holding tanks at a commercial pumpout facility. As there are insufficient facilities, these vessels represent a potential source of raw sewage pollution in Boston Harbor.
- The commercial pumpout infrastructure must be improved so that vessel operators have a convenient way to discharge their holding tanks in a legal manner.
- It is preferable for a sewage pumpout facility to be located in close proximity to where commercial vessels routinely operate.
- The most suitable location for a pumpout facility would be in an area with little residential housing.
- The criteria that must be met in order for a facility to service commercial vessels are significantly more restrictive than the criteria for recreational vessels. Therefore, a facility that can service commercial vessels will, by default, be able to service recreational vessels.
- There is no single location within the Inner Harbor that is in close proximity to where all commercial vessels operate. It was therefore necessary to focus on the commercial vessels that would be expected to contain significant amounts of sewage and do not operate off shore.
- A facility that is capable of servicing all types of commercial vessels would require a shoreside pumpout system and a direct hook-up to a sewer line.
- A facility equipped with both systems would also be capable of servicing recreational vessels.

- This study found that there were two sites that are most suitable for the establishment of commercial pumpout facilities. These were Mystic Marine in Charlestown and Boston Towing and Transportation's 400 Border Street property in East Boston.
- This study recommends that, if sufficient funding is available, both sites be established as pumpout facilities. Mystic Marine should be equipped with a shoreside pumpout system and a direct hook-up to a sewer line so that it can cater to all types of commercial vessels as well as recreational boaters. Border Street should be equipped with only a direct hook-up as this site would cater more to the tugs and other work boats.
- If sufficient funding is not available then Mystic Marine should be the primary location.
- Future waterfront redevelopment in the City of Boston offers the potential to establish other commercial pumpout facilities if demand is sufficient or if changes in regulations warrant this.
- The specific requirements for the necessary equipment at each facility and the costs of installation cannot be accurately estimated until full engineering assessments can be undertaken. Currently, equipment and installation estimates vary between \$40,000 and \$126,000 for the two sites. If engineering assessments reveal significant structural problems, these costs could increase significantly and site selection may have to be reviewed.
- The businesses currently operating at the two sites are in the best position to undertake the operation and maintenance of the pumpout and would need to adhere to an agreed-upon O&M plan.
- Both sites are located in Designated Port Areas and Mystic Marine is on a Massport property and is therefore exempt from Chapter 91 licensing. Therefore, no significant permitting issues are expected with the development of these sites as commercial pumpout facilities.

## SEWAGE FROM VESSELS — AN OVERVIEW

The vessels that utilize the waters of Boston Harbor vary considerably in their sizes, the uses to which they are put and the equipment with which they are fitted. Vessels range from large cruise ships to small recreational vessels. However, one issue that has been a recent focus of attention is the sewage that is produced while boaters are on board.

Vessels can be equipped with a number of different systems that can hold or treat sewage. There are a number of possibilities and whether or not these are fitted may depend on regulations or on the choice of the boater. Many vessels are equipped with an onboard toilet, or “head”. The term head simply applies to the actual toilet, similar to a normal toilet on land. Such heads are in turn connected to a Marine Sanitation Device (MSD). An MSD is a system that either treats the sewage onboard prior to the effluent being discharged over the side, or holds the untreated sewage until the holding tank can be emptied. All MSDs must be of a type that is certified by the US Coast Guard. This only applies to “fixed” systems and such certification does not cover what are commonly called “porta potties”. These are mobile units that can be removed from a vessel and emptied at a shoreside facility.

Currently there are three types of MSD that are recognized by the USCG:

- Type 1 – these treat the sewage onboard before it is discharged into the sea. The form of treatment varies. Simple systems macerate the sewage and then chemicals are added to disinfect the effluent prior to discharge. More advanced systems macerate the sewage and then use electrolysis to produce hypochlorous acid from seawater. The acid is then used to disinfect the effluent prior to discharge into the sea.
- Type 2 – these are similar to Type 1 MSDs in that they treat the sewage onboard prior to discharge. However, Type 2 MSDs do so to a higher standard, thus reducing bacterial levels to a greater degree than Type 1 MSDs. This is done through a three-stage process: aeration, clarification and disinfection. As the onboard treatment is more rigorous, it takes longer and therefore, the effluent is actually retained on board for a period of time.
- Type 3 – these differ from the previous types of MSD in that they do not treat the sewage on board but simply hold the untreated sewage in a holding tank until the tank can be emptied. As this is untreated sewage, it is currently illegal to discharge it into the sea unless the vessel is greater than 3 nautical miles offshore. Only vessels fitted with a “y-valve” can do this. Vessels not so equipped are unable to discharge overboard. If a vessel is closer inshore, the only legal way to empty a holding tank is at a pumpout facility. These are facilities that are designed to receive the untreated sewage and, either directly or indirectly, feed it into a municipal sewer system or a septic system.

Currently, the use of all three types of MSD is legal in Boston Harbor. Type 2 MSDs are uncommon on recreational vessels due to their size and cost. Any vessel over 65 feet in length that is fitted with an installed head must by law be equipped with either a Type 2 or Type 3 MSD. For vessels under this size, the choice is up to the boater and there are no laws requiring that a vessel be fitted with any particular type of MSD. However, if a vessel is equipped with a fixed head, this must connect to one of the three types of MSD.

## THE NEED FOR VESSEL PUMPOUT

Historically, there have been a number of major initiatives aimed at cleaning up the waters of Boston Harbor. Many of these have been highly successful and the water quality within the Harbor has improved dramatically. However, there are still sources of pollution entering the Harbor and therefore, these efforts must continue. One form of pollution that continues to be an issue within the Harbor is that of sewage, and one source of this is the effluent discharged from commercial and recreational vessels. While it is not being suggested that boats are the major source of sewage, it cannot be denied that they are one of the sources.

Boston Harbor continues to serve as a center of maritime commerce and also as an attraction to recreational boaters, both locals and transients. The need for water-dependent facilities within the City waters continues to expand. The development of the Boston Harbor national park area will only lead to a further increase in the number of boats in the area. As it is likely this number will continue to rise, so will their significance as a source of sewage pollution. Discussions held with commercial and recreational boaters in 2002 revealed a willingness to try to reduce sewage pollution from boats, although the preferred methodology varied from user group to user group. One option that has been discussed is to apply to have the waters of the City of Boston designated as a “No Discharge Area” (NDA). Such a designation would make it illegal to discharge treated sewage from boats (i.e. ban the use of Type 1 or Type 2 MSDs within the NDA). One of the key criteria for a successful NDA application is the identification of an appropriate number of sewage pumpout facilities in the area. Such facilities pump sewage from a vessel’s onboard holding tank into the municipal sewer system. It is important to note that there can be differences between the systems used to pump out commercial vessels and those that service recreational boats (see the *General Design and Equipment Requirements* section). Additionally, recreational pumpout facilities that received Clean Vessel Act (CVA) funding are not allowed to service commercial vessels.

On paper there appears to be a reasonable number of facilities within the City of Boston. However, studies conducted in 2002 and discussions with boaters revealed that there are almost no facilities available to the majority of commercial boaters and those that exist are either private, suffer from operational problems or are limited by security issues or a lack of reliable access. Additionally, there are too few facilities available to recreational boaters, and those that are available cannot always be relied upon to be in operation.

The City of Boston has therefore decided that before considering an NDA application, the pumpout infrastructure within the area must be improved. To this end, the City plans to develop a City-sponsored pumpout facility, or facilities, that will service the needs of the commercial and recreational boaters within the City waters.

Our research suggests that under existing regulatory conditions, the primary users of a commercial pumpout in Boston Harbor would be the Boston Harbor Cruises and Bay State Cruises ferry boats, MBTA ferries, and excursion boats that do not travel beyond 3 nautical miles offshore. If the City were to designate a No Discharge Area within the Harbor, additional users would include many of the tug and work boats that operate in the Harbor. At present, some of the larger vessels that use the Harbor, such as container ships, bulk cargo ships, and tankers, normally discharge their sewage when they are over 3 nautical miles off shore. However, they can also be serviced by barges (commonly called “honey barges”) into which they pump their sewage. These barges then discharge their contents at a commercial pumpout facility. Cruise ships normally discharge at sea but can also do so at the Black Falcon Cruise Terminal if necessary. While it is assumed that these larger vessels are complying with the 3 nautical mile regulations, it is important that these regulations are enforced and the discharge activities of such vessels are monitored. However, this issue is beyond the scope of this project.



## EXISTING VESSEL PUMPOUTS

There are 7 pumpouts for recreational boats and 3 pumpouts for commercial vessels within the City of Boston. The pumpouts are illustrated in Figure 1 and listed in Table 1 below.

TABLE 1. Vessel sewage pumpouts in Boston Harbor

<i>Map Reference</i>	<i>Name</i>	<i>Location</i>	<i>Comments</i>
1	Mystic Marine	Mystic Pier 1, 100 Terminal Street, Charlestown	Recreational pumpout and fuel service
2	Shipyards Quarters and Marina	Pier 8, Charlestown	Recreational pumpout
3	Charlestown Pier 4		Commercial pumpout
4	Constitution Marina	28 Constitution Road	Recreational pumpout
5	Boston Boatyard and Marina	256 Marginal Street, East Boston	Recreational pumpout and fuel
6	Boston Yacht Haven	87 Commercial Wharf	Recreational pumpout
7	Boston Waterboat Marina	66 Long Wharf	Recreational pumpout
8	Boston Harbor Cruises	Long Wharf	Commercial pumpout
9	Boston Marina	Rowe's Wharf	Recreational pumpout
10	Black Falcon	Reserved Channel	Commercial pumpout

Previous interviews (summer and fall 2002) with both recreational boaters and marina operators suggest that there is insufficient pumpout service available for recreational boaters in Boston's Inner Harbor. The predominant complaints were that the pumpout equipment was frequently out of operation and that requests for pumpout service were sometimes ignored, leaving boats with full tanks. In such a situation, the boater is either unable to use their MSD, must travel over 3 nautical miles offshore to dump it legally, or can empty the holding tank illegally closer to shore. Marina operators experience many equipment problems with their pumpouts and long delays for service. These drawbacks can be costly over time, and possibly dissuade some marinas from offering the service entirely.

There is an even greater gap in pumpout service available for commercial vessels, such as ferries. Last year, the City of Boston invested in a pumpout system at Charlestown Pier 4. However, the facility cannot service all types of commercial vessels (see the section on *General Design and Equipment Specifications*), is unmanned and access is sometimes restricted due to US Naval activity. The pumpout systems at both Pier 4 and Black Falcon Cruise Terminal are locked and a fee is charged for usage. These sites are discussed in greater detail in the next section. The pumpout at Long Wharf is a private system owned by Boston Harbor Cruises. It was reportedly out of service for almost a year from 2002-2003.

## PROPERTIES CONSIDERED

To select the most appropriate waterfront sites within the City of Boston, we developed a series of siting criteria to guide the process. The initial criteria applied general characteristics most desirable for a commercial pumpout site to highlight the most suitable regions. Qualitative features were also used to suggest specific properties to which we applied more rigorous criteria.

There is an inherent negative perception of facilities that, like a vessel pumpout system, store and convey sewage. This perception would be least problematic in a region with a concentration of commercial and industrial water-dependent uses, where access is easy and vessel traffic is high, and where there is a low concentration of residential development. Figure 1 shows the water-dependent uses of the City of Boston's waterfront. A preliminary scan of the shoreline highlights three regions where water-dependent land uses are concentrated (Figure 2).

**Region 1: South Boston Seaport District.** This area is part of the South Boston Designated Port Area. Much of the waterfront land in the Seaport District is owned by the Massachusetts Port Authority (Massport) and by the City of Boston's Economic Development and Industrial Corporation (EDIC). There is no residential development in this region at this time. Water-dependent uses in the area include:

- Northwest side of the World Trade Center: The Spirit of Boston excursion boat and the Provincetown II ferry both tie-up and load passengers.
- Boston Fish Pier: Lobstermen and fishermen can tie-up, refuel from a fuel truck, load and unload; a number of fish wholesalers, an ice merchant, and Massport offices are located on the site.
- Black Falcon Cruise Terminal: Serves a number of cruise ship lines where passengers load and unload. Peak cruise season is September and October. A pumpout line exists on the site.
- Conley Terminal: A large container terminal featuring gantry cranes and deep draft berths.

**Region 2: Downtown Boston/East Boston.** In downtown Boston there are a number of small marinas mixed with residential development. Other water-dependent uses include

- Constitution Marina in Charlestown at the mouth of the Charles River.
- Boston Tow and Transportation in East Boston, which provides tugboat and workboat service.

Redevelopment is planned for much of this part of East Boston, including two new residential developments with small marinas—Clippership Wharf and Pier 1 (East Boston Master Plan 2000).

**Region 3: Charlestown Mystic River/East Boston Chelsea Creek.** The upper reaches of Boston's Inner Harbor support an array of marine industrial activity.

- Massport's Auto Port—formerly the Moran Terminal—is located on 65 acres at the confluence of the Mystic River and Boston Harbor.
- Diversified Automotive leases waterfront space on the Little Mystic Channel and operates Mystic Marine that provides fuel and pumpout services.
- Boudreau's Boatyard on Chelsea Creek.

- Largely vacant marine industrial site at 400 Border Street (discussed below).  
Public residential housing and nonwater-dependent commercial uses are also prevalent.

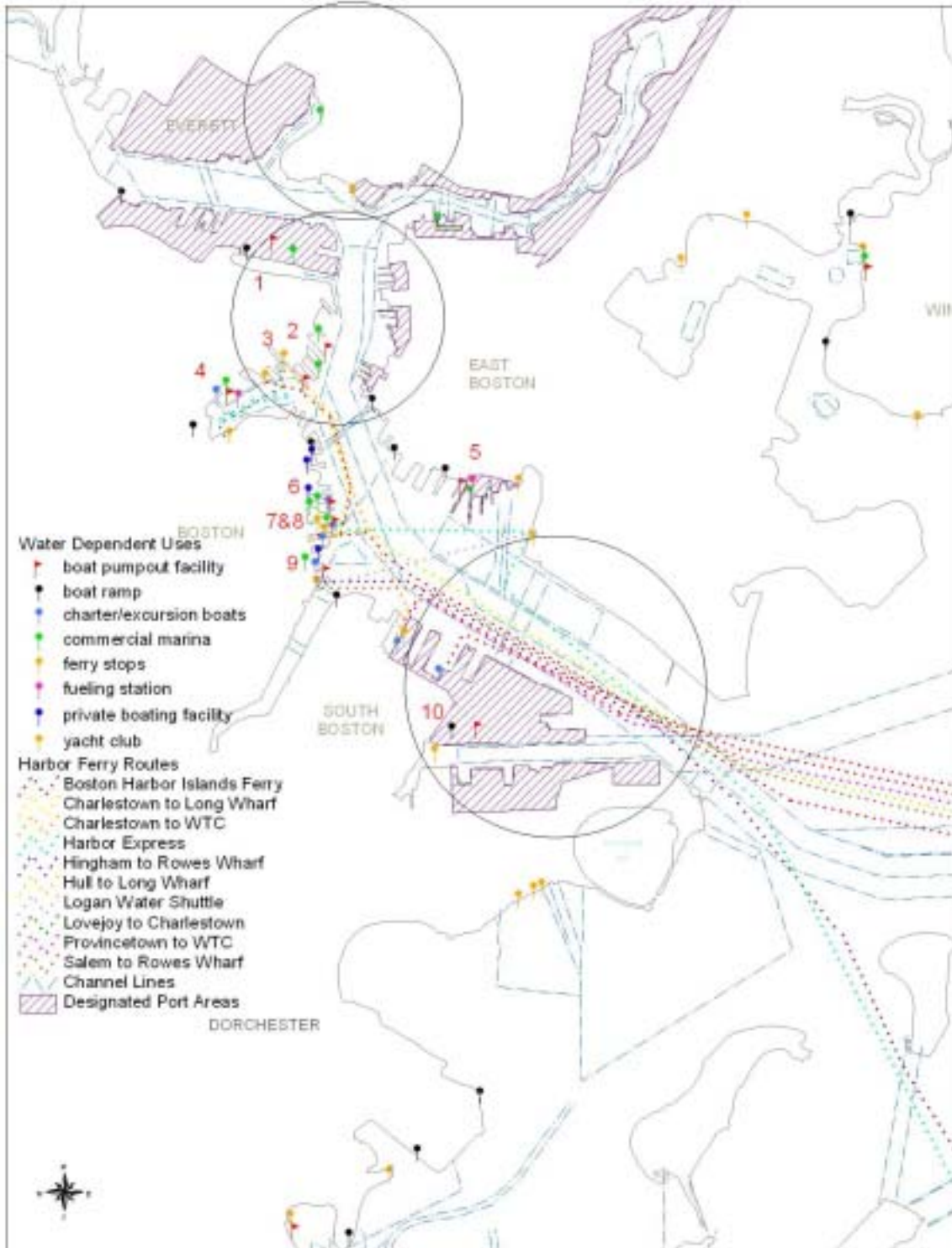

FIGURE 1. Water-dependent uses in the City of Boston (Data source: MassGIS, UHI). Boat pumpouts are displayed and numbered in red.

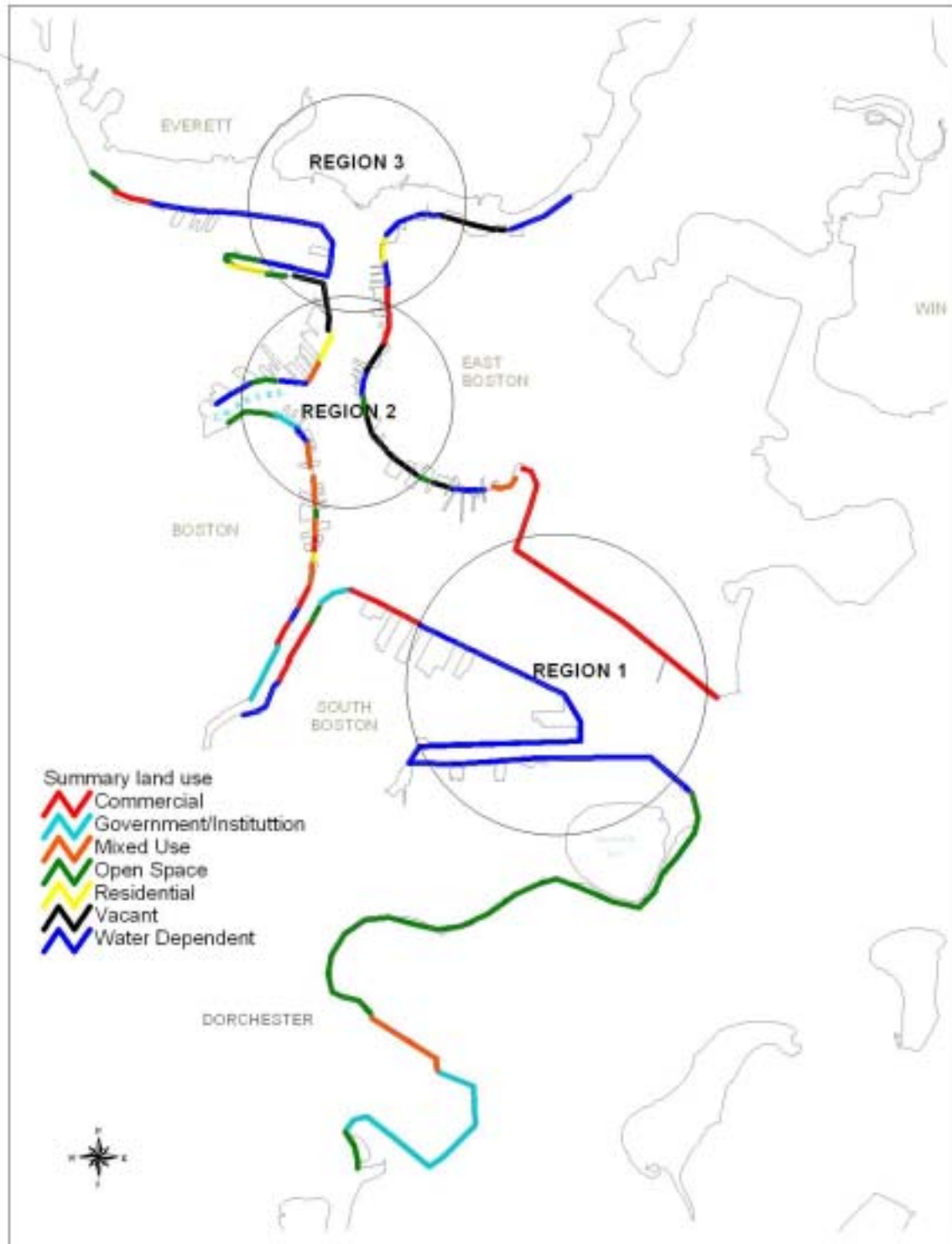

FIGURE 2. Summary of land use along City of Boston's shoreline (Data Source: MassGIS and UHI)

The highest concentration of residential development and the least marine industrial activity is within Region 2. There are also large tracts of land on the East Boston side that are underutilized and slated for redevelopment. Apartment and condominium complexes are planned on these sites. Unique opportunities exist for the City and state to require that water-dependent facilities—such as a commercial-grade pumpouts, fuel docks, or marinas—also be constructed on the sites as part of the permit process. Unfortunately development is yet to begin and may be years away from completion. The timeframe for this project is to construct the pumpout within the next year. So unless it is determined that potential sites in Regions 1 and 3 are unworkable, Region 2 will be eliminated from the site selection process.

Within Region 1 and 3, we selected four locations (Figure 3) for further review because they shared the following attributes: (1) they were mentioned as well-suited properties during a commercial vessel operator meeting on a possible No Discharge Area designation for Boston Harbor, (2) they had piers with existing pumpouts or sewer connections, and (3) the property or business owners expressed interest in such a project. The four properties include Mystic Marine Fuel, Boston Towing and Transportation's 400 Border Street site, Charlestown Pier 4, and Black Falcon Cruise Terminal. More detailed analysis of each property is presented below. The criteria applied to each property are presented in Table 2. A maximum of one point is awarded for each property that meets the criteria and the sum is totaled in the last row of the table.

### ***Mystic Marine Fuel***

Contact: Dennis Kraez, Diversified Automotive  
Property Owner: Massport

Mystic Marine Fuel is a commercial marina providing fuel and sewage pumpout services to both recreational and commercial vessels in Boston Harbor. With 12 fueling stations, 3 pumpout hookups, and 300 feet of accessible dock space (approximately 55 feet of which is floating dock), they can service 100 or more boats per day on weekends. Mystic Marine estimates that they refuel 70 percent of the recreational boats in Boston Harbor and 50 to 60 percent of the commercial fleet (all 12 Boston Harbor Cruises vessels and most Baystate Cruise vessels refuel at Mystic Marine). Larger vessels can forego the floating dock and tie up alongside the pier. Mystic Marine is equipped with a Waubaushene LD125 shoreside pumpout system that is used for smaller vessels. This consists of a 125-gallon tank (or "transfer cell") connected to a two-way vacuum pump. The pump sucks the sewage out of a vessel and into the tank. When the tank becomes full it automatically switches to discharge mode where the sewage is pumped into a 985-foot section of 8-inch sewer line and from there, into the Moran Terminal wet-well, or catch basin. The sewage waste pipe from the vessel to the tank runs along the floating dock. All pipes are stainless steel and above ground; no pipes are in the water. A number of different pumpout adapters accommodate different deck fittings.

Recreational boats are offered pumpout service during refueling; there is no charge for these pumpouts. The pumpout boat from Constitution Marina sometimes unloads its sewage waste at the Mystic. Mystic Marine used to offer pumpout services to larger, commercial vessels. Such vessels are equipped with onboard pumps that pumped the sewage up to a dedicated pipe connection on the dock. From here it bypassed the recreational Waubaushene pumpout and traveled directly to the wet-well. Unfortunately, Mystic Marine can no longer accept sewage from large-capacity vessels, such as the harbor ferries, as there have been frequent problems with the two pumps that "lift" the sewage from the wet-well into the Boston Water and Sewer Commission (BWSC) pipes.

Originally, the wet-well was equipped with two ABS Piranha<sup>®</sup> pumps. However, these had to be replaced a number of times. Passengers sometimes put items such as plastic cutlery into the

head and these then end up in the holding tank. It was thought that if these were passing through the ABS pumps they could result in their malfunction. Massport therefore decided that Mystic Marine could no longer offer the service unless the pumps were upgraded. Further details can be found in the *Design and Equipment Requirements* sections of this report.

Mystic Marine attributes its success as a fuel dock to their discounted fuel prices that are the lowest in the Harbor. They feel strongly that this is an ideal site for pumping out all kinds of boats because it can be done conveniently while vessels are fueling and trained staff are on hand to operate the systems.

There exists an additional opportunity at Mystic Marine for the City to combine its efforts. During the time of our interview with Dennis Kraez, we learned that Mystic Marine was working with the City to provide parking for the coaches that pass through Boston either as part of a routine travel schedule or a special tour. The coaches currently park in the Seaport District but have to relocate. Mystic Marine can provide space for parking and daytime accommodation for drivers. With some modifications and upgrades to the existing pumpout, they would also be able to remove the bus sewage.

### ***Boston Towing and Transportation***

Location: 400 Border Street, East Boston  
Property Owner: Jonathan Wales  
Contact: Phil Chase

Boston Towing and Transportation (BTT) is the largest private landowner in East Boston. With 13 tugs (each about 100 feet long and with a draft of 15 feet), BTT is well-located for bringing ships into the Harbor.

BTT's 10-acre property at 400 Border Street would be well-suited for a commercial pumpout. It is within the East Boston Designated Port Area and the City's Maritime Economic Reserve. There are four concrete piers on the site, each of which is over 100 feet in length. The water depth ranges from a minimum of 20 feet to a maximum of 30 feet at MLW. The piers are used by the tugs, visiting vessels, and as a staging area for construction projects. The upland portion of the site is in somewhat of a state of disrepair. However, this is not unusual for industrial waterfront businesses and it is likely that the state of disrepair is largely superficial and would not affect the ability of the site to be used for a commercial pumpout.

At one time, the site had freshwater, a fire main and sewer line that ran out to the main pier. The sewage was fed into a catch basin and then it was pumped up to the municipal sewer system (a height, or "head", of about 15 feet). Currently, the pumps in the catch basin are not operational.

BTT estimates 700 oil barges visit per year from New York City and the Mid-Atlantic States. Most barges are typically in the harbor for 2-4 days and, by law, cannot be left unattended. The tugs can have crews of six or more people and there is a limit to how much sewage the onboard MSD systems can hold. At this time, the tugs are outfitted with Type II MSDs, which treat and discharge sewage into the Harbor.

BTT provides pumpout service to the US Navy using a small Navy surplus vessel that holds approximately 78,000 gallons of sewage. This honey barge usually discharges at the pier-side commercial-grade pumpout at Charlestown Pier 4 or at the Black Falcon Cruise Terminal.

A new pumpout on this site could be located on the main concrete pier. Smaller boats could hook up directly to a dockside manifold while larger vessels would be serviced by the honey barge. BTT does not sell fuel.

### ***Charlestown Pier 4***

Location: Charlestown Navy Yard

Owner: City of Boston

Contact: Larry Mammoli

Pier 4 is one of the US Navy's three main berths in the Harbor. The pier is long enough to accommodate 80% of the classes of Navy vessels that visit the Harbor (approximately 200 feet). It has an existing commercial-grade pumpout with a manifold hookup that is locked when not in use. The Navy occasionally ties up at this site, during which time the pumpout would not be available to other vessels because of security constraints. The Navy is charged the BWSC's combined water/sewer rate when it uses the sewage pumpout.

Last year, the City upgraded the sewer connection to a 4-inch sewer line. The cost of the existing water and sewer connections is estimated at \$50,000. At present, the line does not have a meter, but it could be easily added to monitor sewage flow. The pumpout system does not have a pump, so to use it a vessel would need to be equipped with its own onboard sewage pump.

To be used as a commercial facility available to other users, the system would have to be metered, a fee would have to be levied and security issues would have to be addressed. Additionally, it would be necessary for the pumpout to be staffed when in use because of concerns that someone would pump bilge water contaminated with oil into the sewer system.

Larry Mammoli suggested a site in South Boston Marine Industrial Park as another possible site, but cost would be an issue because an additional 60 feet of sewer pipe would be needed.

### ***Black Falcon Cruise Terminal***

Location: South Boston Seaport District

Owner: Massachusetts Port Authority

Contact: Brad Wellock

The pumpout at Black Falcon is similar in design to the one at Pier 4. A 4-inch sewer line runs from a connector on the dock to an underground open spillway and into the BWSC sewer system. There is no pump to lift the sewage out of the boat and the system is not metered. Massport charges a flat fee of \$165 and then \$1.30 per ton, which is charged to cover Massport's BWSC fees.

The system at Black Falcon pumps out the occasional cruise ship—only one every two to three years—and the BTT honey barge. Anyone wanting to use it must make prior arrangements as the connector is locked. When a cruise ship is in port (almost every day between September and October) it is not physically possible for another commercial boat—such as a ferry—to access the pumpout. When there are no cruise ships at the facility, there is no staff available to unlock the pumpout.

In the past, honey barges would pumpout at night. This is no longer an option due to increased security. Unsupervised pumpout is also not an option due to the possibility of people pumping bilge water contaminated with oil and other hydrocarbons into the sewer system. However, if the facility were to be manned so that other vessels could pumpout, Massport would have to increase the fees that they would have to charge to cover the staff.



FIGURE 3. Color orthophotograph showing the location of the four sites that were assessed for this study (Data Source: MassGIS and UHI)



## DESCRIPTION OF CRITERIA USED

The main aim of this study was to assess the most suitable site for a commercial pumpout. Some commercial vessels are equipped with onboard pumps to discharge their sewage, while others require shoreside pumps. If a commercial pumpout facility was to be able to cater to all commercial vessels, it would require both systems (see the *General Design and Equipment Requirements* section for further explanation). Therefore, any facility that was equipped with a shoreside pumpout system could also service recreational vessels. At present, there are a number of other facilities in the area that service recreational vessels and very few that service the commercial fleet. Commercial vessels tend to be larger, have deeper drafts, are less maneuverable, hold larger volumes of sewage and are more pressed for time than recreational boats. Therefore, a facility that can cater to large commercial vessels should present few access restrictions for recreational boaters. Therefore, the criteria that were developed were aimed specifically at addressing the more demanding requirements of commercial usage. These were:

1. Sufficient water depth – A minimum water depth of 20 feet is required in the approaches and alongside the dock to ensure access for most commercial vessels. Vessels that require greater depths could be serviced by a honey barge.
2. Sufficient room to maneuver – Larger vessels are less maneuverable than smaller ones and therefore any site must provide sufficient room to allow for this.
3. Proximity to commercial traffic – A site must be near to where commercial vessels are operating or where they will be during routine operations, such as refueling and docking.
4. Sufficient dock length – The dock or pier must be long enough to accommodate large vessels.
5. Dock space availability – The dock must not be regularly blocked by other vessels.
6. Current state of dock – Docks in severe disrepair may require additional funds to rectify the situation.
7. Gravity feed or pump – Gravity feed refers to a sewer line that runs on a down-gradient from the connector to the municipal sewer system. If this is not the case, additional pumps will be required to lift the sewage into the sewer system. Neither system is necessarily better than the other although pumps require maintenance.
8. Tie to municipal sewer – Proximity to municipal sewer lines will determine how much additional sewer line is needed, if any. If sewer lines are already in place this reduces the costs of installing a pumpout system.
9. Existing infrastructure – Is there a functional pumpout on the site already? Does this pumpout have a shoreside pump or does it depend on the vessel having an onboard pump?
10. Other amenities – Does the site offer a service other than pumpout, such as fueling, that would attract commercial vessels?
11. Staff – Would staff be available to pumpout the boats, or would it be self-serve? If staff were available they could operate the equipment and deal with any problems that may arise. However, if additional staff were required to oversee the pumpout, this cost would have to be passed on to vessel operators.
12. Security – Are there security concerns under the new Homeland Security regulations? If a site were to be closed in times of heightened security, this would prevent vessels from utilizing the pumpout.
13. Land ownership – Siting a municipal pump out on private property would require an easement.

14. O&M organization – Who currently operates on the site and who would assume responsibility for operating and maintaining the system?

Using these criteria and an equal-weighted scoring system, two properties stand out as most appropriate for the siting of a commercial pumpout: Mystic Marine and 400 Border Street. Possible equipment requirements and preliminary cost estimates for these two sites are provided in later in this document.

While both sites are within the Inner Harbor, it is felt that this is not a significant limitation. Many commercial vessels already use sites within the Inner Harbor for refueling or docking and therefore would be in close proximity to the potential pumpout sites during routine operations. As discussed earlier, the largest commercial vessels, such as cruise ships and tankers etc., rarely pump out when in the Harbor. For example, it was reported that a cruise ship only discharges at the Black Falcon Cruise Terminal every two to three years. There is also the option for such vessels to be serviced by a honey barge (BTT services some Navy vessels using a 78,000 gallon-capacity honey barge) or to use Black Falcon Cruise Terminal. Due to the fact that large commercial vessels utilize shoreside pumpout so infrequently, it is felt that siting a commercial pumpout facility specifically to cater to these vessels should not be considered at this time. However, as various redevelopment plans for the Boston waterfront are considered, it may be possible to include additional commercial pumpout facilities in the future.

The commercial fishing fleet in Boston Harbor represents a group of vessels that is unlikely to frequently venture into the Inner Harbor. It is reported that tanker trucks normally refuel these vessels and that honey trucks have not been seen to service them. They therefore represent a potential source of sewage discharge in the Harbor. However, it is felt that even if a commercial pumpout facility were located in close proximity to where they dock, fishing vessels would be unlikely to use it frequently. There are a number of reasons for this:

- Many of the vessels are operated over 3 nautical miles offshore where they can legally discharge their sewage overboard.
- Smaller commercial fishing vessels that tend to operate closer inshore are often not fitted with an MSD or fixed head, and if they do have an MSD it is often a Type 1 that has no holding tank and directly discharges it into the sea.
- Many of these inshore vessels have a small complement of crew (one to two people on a typical lobster boat) and therefore the amount of sewage generated is of less significance than the amounts that are produced by numerous passengers on a ferry.

If, in the future, segments of Boston Harbor are designated as No Discharge Areas, fishing vessels equipped with Type 1 or Type 2 MSDs would need to be retrofitted with holding tanks. If this were to occur, it would be likely that the demand for shoreside pumpout facilities that could service commercial vessels (i.e. not CVA funded) would increase. At such a time it may be necessary to revisit the issue of siting such a facility in closer proximity to the fishing fleet. However, this potential demand may be addressed in the Commonwealth Flats Watersheet Plan that is currently being developed by Massport. At this time, the plan calls for the establishment of a pumpout facility in the vicinity of the ice making business on the Fish Pier.

This study has had to focus on the current demand for commercial pumpout services. In the future, with possible No Discharge Area designations, changes in the make-up of the commercial fleets and proposed redevelopment plans for various areas of the Boston waterfront, the demand may change and other commercial pumpout facilities may be required. However, it is felt that at the present time, and taking into account limited resources, the two sites in the Inner Harbor are best suited for servicing a significant proportion of the commercial vessels in Boston Harbor. While these locations are clearly not “ideal” for all commercial

operators (“ideal” being having a pumpout where their vessels are docked), they represent a realistic and practical option at this time.

Figure 4 shows the distances of various locations within Boston Harbor from the potential pumpout sites. The Fish Pier is approximately 2 miles from the sites and Conley Terminal is 3 miles away. While these distances are not great, it should be noted that once a vessel passes a line between the Fish Pier and the Hyatt Hotel, it has entered a “No Wake Zone” where its speed is restricted to 5 nautical miles per hour or less.



FIGURE 4. The approximate distances of locations within Boston Harbor from the two proposed commercial pumpout sites (Data Source: MassGIS and UHI)

TABLE 2. Criteria for commercial pumpout sites along Boston's coastal waterfront

<b>Criteria</b>	<b>Mystic Marine</b>		<b>400 Border Street</b>		<b>Navy Yard – Pier 4</b>		<b>Black Falcon</b>	
Sufficient water depth	Ample (~40 feet)	1	Ample (>20 feet)	1	Ample (~40 feet)	1	Ample (~40 feet)	1
Sufficient room to maneuver	Excellent. Ample room to turn, etc. in the channel by the dock. Mainly recreational boaters accessing fuel/dock/pumpout.	1	Plenty of room to access piers without turning. Piers are near to the channel so turning etc. would be in or near the channel.	1	Excellent	1	Excellent	1
Proximity to commercial vessel traffic	Yes	1	Yes	1	Yes	1	Yes	1
Sufficient dock length	Approximately 300ft of pier including a floating dock	1	4 concrete piers, each over 100 feet	1	Approximately 200 feet: sufficient to accommodate navy vessel so ok	1	Several 100 feet; sufficient to accommodate cruise ships so ok	1
Dock space availability	Unless being used by other vessels for fueling etc. this is no limits to space availability	0.75	Some oil barges tie-up here but with 4 piers this should not be an issue	1	Unavailable when in use by the navy. Otherwise would require pre-arranging to ensure that staff could be available	0.5	Unavailable when cruise ships in port. Unavailable outside working hours as no staff available. September and October are peak season for cruise ships.	0.25
Current state of dock	Excellent	1	In need of some repair	0.75	Excellent	1	Excellent	1
Gravity feed or pump to municipal system	Pump	1	Pump	1	Gravity	1	Gravity	1
Tie to municipal sewer system	Yes but pumps need replacing	0.5	Yes but pumps need replacing	0.5	Yes, currently working	1	Yes, currently working	1
Existing infrastructure	Pipe runs along dock but 2x pumps necessary to feed into municipal system are broken.	0.5	Pipe runs along dock and into a catchbasin. Then pumped to feed into municipal system. Pumps are broken and state of the catchbasin is unknown	0.5	Working pipe is in place and locked. No way to meter at present although that is a simple fix. Seems to be reliable but no personnel on site.	1	Working pipe in place and working with few problems. Unmetered.	1
Other amenities (fuel etc.)	Fuel is available for recreational boaters (12 pumps) and commercial vessels. Pumpout is available to recreational boaters who are customers (3 hookups, one shoreside pump)	1	None	0	None	0	Multiple but geared to the cruise ships, not general commercial vessels.	0

*Continued on next page*

<b>Criteria</b>	<b>Mystic Marine</b>		<b>400 Border Street</b>		<b>Navy Yard – Pier 4</b>		<b>Black Falcon</b>	
Staff	Yes	1	Yes	1	Would need to prearrange to ensure staff present	0.25	Staff present when there is cruise ship activity. If extra staff are required it would be expensive because they are union.	0.25
Security Issues	The Auto Port will have to develop a facility security plan but if vessels are not carrying passengers this should not be an issue.	1	No security issues.	1	Security is tight when the navy are using the facility. Otherwise no security issues.	0.25	Major security issues. Channel will be closed when country is on high alert. No access when staff are not present.	0
Land ownership	Massport (leased by Diversified Automotive)	1	Private (Boston Towing & Transportation)	0.75	Massport	1	Massport	1
O&M organization	Diversified Automotive	1	Boston Towing & Transportation	1	Massport	1	Massport	1
General Comments	This seems like an excellent site and this is strengthened by the fact that many commercial vessels already use the site for fuel.		This seems like an excellent site but the fact that fuel is not sold means that its use would require a special journey.		Limited availability of the site means that it is not ideal. However, if a meter were added it could then be used by particular vessels that might want to contract with Massport.		Due to security issues and the fact that the facility is frequently unavailable due to cruise ships, this site is not suitable. The US Coast Guard also said that this would not be a good choice due to security.	
<b>SCORE</b>		<b>12.75</b>		<b>11.5</b>		<b>11</b>		<b>10.5</b>

## REQUIRED PERMITS

This section outlines the types of permits that may be required for the construction of a commercial pumpout on the waterfront within the jurisdiction of the City of Boston. This analysis is limited because full information concerning the development of commercial pumpouts at either location is unavailable at this stage—particularly, detailed information on the physical conditions of the underlying infrastructure. We have confirmed that both properties have existing sewer infrastructure, existing docks, and adequate channel depths. Assuming that we do not encounter any difficulties that would require construction of a new structure or modifications to an existing structure, it is expected that the permits will be for minor modifications to the site.

Permits anticipated for this project are listed below (Table 3) and described in greater detail in the text that follows.

TABLE 3. Summary of permit requirements for commercial pumpout

	<b>Mystic Marine</b>	<b>400 Border Street</b>
<b>Federal</b>	<ul style="list-style-type: none"> <li>• None</li> </ul>	<ul style="list-style-type: none"> <li>• None</li> </ul>
<b>State</b>	<ul style="list-style-type: none"> <li>• Exempt from Chapter 91</li> <li>• Sewer System Extension and Connection Permit</li> </ul>	<ul style="list-style-type: none"> <li>• Chapter 91 “Minor Modification”</li> <li>• Sewer System Extension and Connection Permit</li> </ul>
<b>MWRA</b>	<ul style="list-style-type: none"> <li>• Direct Sewer Connection Permit</li> <li>• Septage Discharge Permit</li> </ul>	<ul style="list-style-type: none"> <li>• Direct Sewer Connection Permit</li> <li>• Septage Discharge Permit</li> </ul>
<b>Municipal</b>	<ul style="list-style-type: none"> <li>• Order of Conditions</li> <li>• Building Permit</li> <li>• Exempt from zoning</li> </ul>	<ul style="list-style-type: none"> <li>• Order of Conditions</li> <li>• Building Permit</li> <li>• Exempt from zoning</li> </ul>

### **A. State Permits**

#### *1. Department of Environmental Protection (DEP).*

The Massachusetts DEP Bureau of Resource Protection regulates activities on filled or flowed tidelands under the Public Waterways Act (M.G.L. c. 91) and the corresponding waterways regulations (310 CMR 9.00). Tidelands refer to all land presently or formerly beneath the ocean. These areas are government by a pre-colonial legal doctrine known as the public trust doctrine, which established that all rights in tidelands and the water are held by the state “in trust” for the benefit of the public.

The property at Mystic Marine is owned by the Massachusetts Port Authority, and as such is exempt from the Chapter 91 license program. The property at 400 Border Street has an existing permit (see attached) and will need to submit a “minor modification” to an existing license (310 CMR 9.22) prior to constructing the new pumpout and making modifications and/or repairs to the existing infrastructure.

DEP Bureau of Resource Protection also regulates the construction, maintenance, modification, or use of any sewer system extension or connection pursuant to the Massachusetts Clean

Waters Act (M.G.L. c.21 §43) and the corresponding Sewer System Extension and Connection Permit Program (314 CMR 7.00).

2. *Massachusetts Water Resource Authority (MWRA)*

A Direct Sewer Connection Permit is required to make a direct connection to MWRA's sewer system or to reconnect or modify an existing connection pursuant to 360 CMR 10.081.

In addition, a Septage Discharge Permit is required by anyone who commercially pumps, transports, or discharges septage and who directly or indirectly discharges into the MWRA sewer system.

**B. *City of Boston***

1. *Conservation Commission*

In Massachusetts, the municipalities and townships enforce the Wetlands Protection Act and associated regulations and policies by issuing an Order of Conditions. The wetlands laws give Conservation Commissions jurisdiction over projects that will affect "areas subject to protection," including, but not limited, to land under water bodies. The primary function of a Conservation Commissioner is to protect natural resources. It is envisaged that the establishment of a commercial facility at either site would not impact the sea floor unless the docks or piers required significant repair. If it transpired that this were the case, it is expected that the site would have to be rejected as such repairs would be cost prohibitive.

2. *Inspectional Services*

A Building Permit is required from the City of Boston to ensure that the pumpouts are constructed in accordance with the Massachusetts State Building Code. At this stage in planning, it is uncertain whether a Short Form or Long Form permit or a permit amendment will be needed.

## GENERAL DESIGN AND EQUIPMENT REQUIREMENTS FOR PUMPOUT FACILITIES

There are differences in the pumpout requirements for commercial vessels depending on how they are equipped. Additionally, there are also differences between commercial and recreational vessels. If a facility is to cater to all types of vessels then these differences must be addressed.

There are a number of differences between commercial and recreational vessels when it comes to MSD design. As discussed previously, there are three types of MSDs. Type 1 and Type 2 have onboard treatment and the effluent is then discharged to the sea. A Type 3 MSD has a holding tank that can be emptied at a pumpout facility. Recreational vessels that are fitted with a Type 3 will require a pumpout that has a pump located on the shore or on a boat as they do not have a pump on board to force the sewage, or “black water” up off the vessel. The onboard holding tank is connected to the deck by a hose and this connects to a deck fitting through which the pumpout machinery can suck the sewage. It is then either stored in a tank or runs directly into the municipal sewer system. The design of the deck fitting is not standard but there are a limited number of designs currently in use. Operators therefore have a series of adaptors to facilitate connection to whatever type of fitting the vessel is equipped with. Graywater is that which comes from the galley, sinks, showers or perhaps washing machines. Due to size restrictions, recreational vessels rarely store the graywater and it is simply discharged into the sea

Commercial vessels are frequently of a different design. Due to the larger number of people on board, the volumes of both graywater and black water produced are greater. The volumes also depend on the type of activity in which that vessel is engaged. A study on “The Impact of Cruise Ship Wastewater Discharge on Alaska Waters” from November 2002 estimated that on a large cruise ship, graywater may be produced at up to 50 gallons per person per day. On smaller cruise ships the figure is estimated at somewhere around 25 gallons per person per day. On all cruise ships, black water is produced at about 5 gallons per person per day. While this figure may seem very high, it should be noted that the black water volume is inflated due to saltwater flushing of the heads. Additionally, these figures were for vessels on which the passengers and crew stayed over night. The same study concluded that a vessel with 96 passengers and crew on board could produce approximately 2400 gallons per day of graywater and up to 480 gallons of black water (Table 4).

The same study also found that the volume of graywater produced on ferries was less than 25 gallons per person per day as the passengers are rarely aboard for prolonged durations and some facilities, such as laundries and showers, are not often available. Black water production was estimated at 2.5 gallons per person per day (Table 5).

Due to their size, smaller ships may not be able to hold the volume of graywater and may simply discharge it over the side. Larger vessels may have more storage capacity and may store the graywater until they are alongside a dock when they can discharge it into a drain. Some vessels mix their graywater with the black water in order to dilute the sewage prior to discharge.

Larger commercial vessels (greater than 65 feet) must be equipped with either a Type 2 MSD or a Type 3. If equipped with a Type 2, the sewage is treated on board prior to being discharged. However, the treatment consists of a three-step process, which means that sewage is held on board for a period of time. It is only moved through the steps in the process as more sewage is added to the system. Therefore, the duration that the sewage is on board is dependent on how frequently the head is used. The tugs that are in, or visit, Boston Harbor are frequently equipped with such MSDs. Additionally, the crews remain on board when in port and therefore they will be producing larger volumes per person of both black water and graywater than, say, the ferries. While Type 2 MSDs have a limited holding capacity, it is unlikely that this would be sufficient to hold the sewage from the crew during the whole time in port.



Many of the ferries in Boston Harbor are equipped with Type 3 MSDs that require pumping out unless the ferry is equipped with a y-valve. If this is the case then the Captain can empty the holding tank when greater than 3 nautical miles off shore, or do so illegally closer to shore.

Pumpout services do not normally receive graywater, unless it has been mixed with the sewage, as they are primarily designed for receiving sewage. Many commercial pumpouts are not equipped with shoreside pumps that smaller vessels require (Figure 5). Instead, many larger ships have onboard pumps that force the sewage up to the dock and directly into the sewer line through a manifold (Figure 6). At that point it either runs through the sewer via gravity (as is the case at Black Falcon and Pier 4), or it needs to be “lifted” up to the municipal sewer, requiring another set of pumps (as is the case at both Mystic Marine and BTT’s 400 Border Street property). If a vessel is not equipped with an onboard pump, then it must be emptied using a shoreside pump with sufficient suction power and holding capability.

TABLE 4. Estimated graywater and black water produced by cruise ships of various sizes in “The Impact of Cruise Ship Wastewater Discharge on Alaska Waters” study carried out for the Alaska Department of Environmental Conservation in November 2002

Ship Name	Length (feet)	Maximum # of people	Max. Black water Produced (gallon/day)	Max. Graywater Produced (gallon/day)
Wilderness Adventure	100	96	480	2400
Wilderness Discoverer	110	120	600	3000
Sea Bird	150	96	480	2400
Sea Lion	150	102	510	2550
Clipper Odyssey	200	204	1020	5100
Yorktown Clipper	200	200	1000	10000
Hanseatic	400	320	1600	16000
Spirit of Oceanus	295	178	890	8900
Spirit of Discovery	166	105	525	2625
Spirit of '98	192	122	610	4880
Spirit of Columbia	143	99	495	2475
Spirit of Alaska	110	95	475	2375
Spirit of Endeavour	217	130	650	3250

TABLE 5. Estimated graywater and black water produced by ferries of various sizes in “The Impact of Cruise Ship Wastewater Discharge on Alaska Waters” study carried out for the Alaska Department of Environmental Conservation in November 2002

Ship Name	Length (feet)	Maximum # of people	Max. Black water Produced (gallon/day)	Max. Graywater Produced (gallon/day)
Taku	300	412	1030	4120
Columbia	350	566	1415	5660
Malaspina	350	550	1375	5500
Matanuska	250	548	1370	5480
Kennicott	400	790	1975	7900

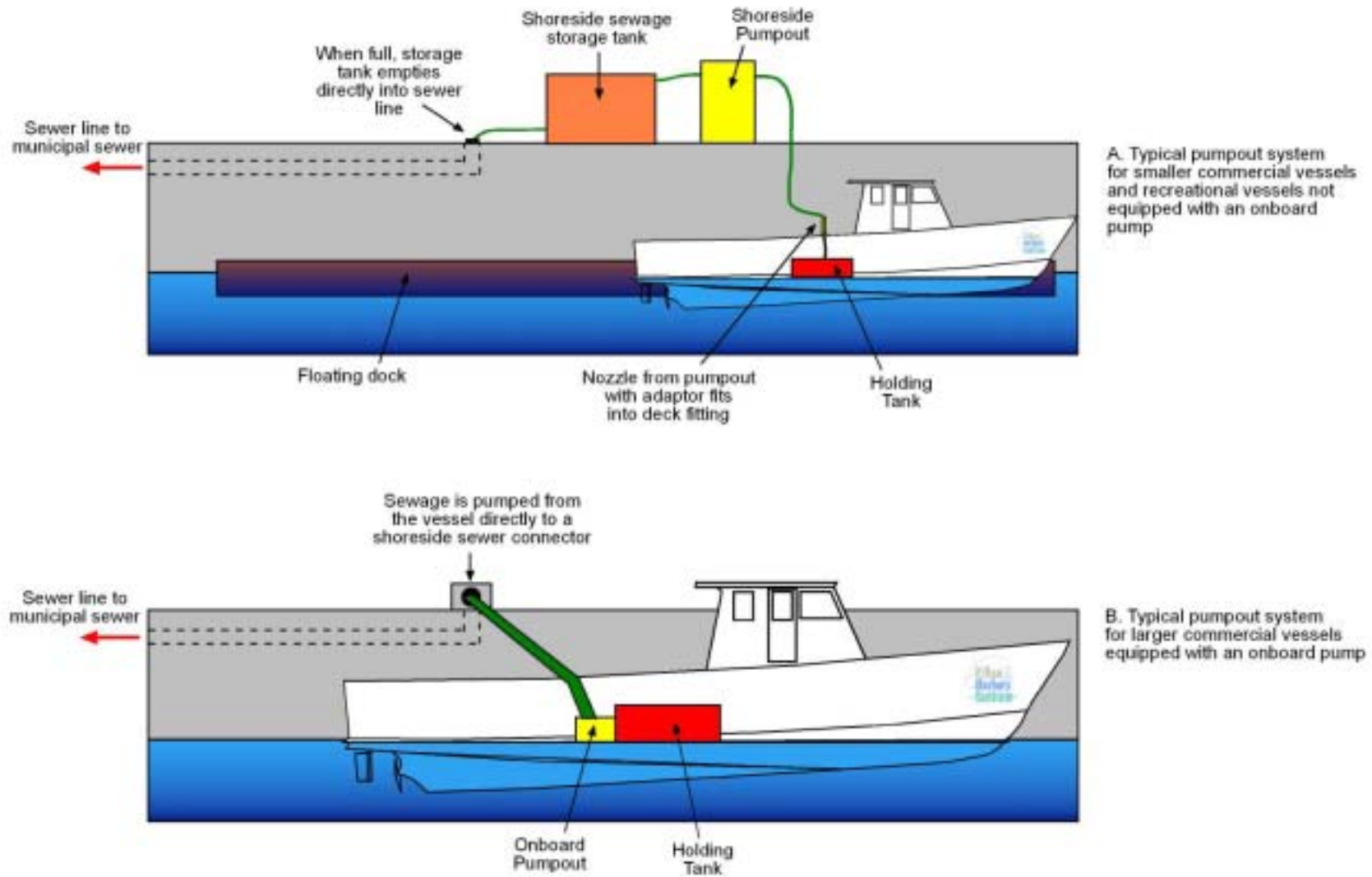

FIGURE 5. The differences between (A) pumpout systems that cater to vessels that do not have onboard sewage pumps and (B) those that do. The majority of larger commercial vessels will have onboard pumps, while recreational and smaller commercial vessels will require shoreside pumps.



FIGURE 6. A typical shoreside manifold to which a large commercial vessel would connect its discharge hose and pump its effluent directly up and into a sewer line. The photograph is of the connector at Pier 4. Photograph: UHI

## DESIGN AND EQUIPMENT REQUIREMENTS FOR THE SELECTED SITES

As discussed previously, the site selection process identified two locations in Boston Harbor that were deemed to be the most suitable for the establishment of a City-sponsored commercial pumpout facility. These are Mystic Marine and BTT's site at 400 Border Street in East Boston. As mentioned earlier, both sites have sewer lines that run along or under their docks and both systems run into a catch basin or wet-well from which the sewage must be pumped up into the municipal sewer system. While full engineering surveys would be necessary to ascertain the exact state of the existing systems, it is known that the pumps at 400 Border Street would require replacing as they are non-operational, and those at Mystic Marine, while currently functional, would require upgrading (as explained below).

As much of the infrastructure already exists at both sites, establishing a commercial pumpout would be more a case of fixing what is there rather than building a facility from scratch. Our recommendation is that, if sufficient funding is available, both sites should be developed as commercial pumpout facilities. This would mean that it would be highly unlikely that both sites were non-operational at the same time and would allow commercial Captains simply to cross the Inner Harbor to the alternative site if the first pumpout was in use. It is for these reasons that we feel that two sites would be most appropriate. Additionally, we would envisage that each site would cater to a slightly different clientele. Mystic Marine currently attracts a great deal of the recreational pumpout activity due to discounted fuel prices, easy access and a free service. They previously offered commercial pumpout until Massport prohibited them from doing so. Additionally, many of the commercial vessels operating within the Harbor take on fuel at Mystic Marine. If commercial pumpout was once again available, the site could offer "one-stop-shopping". In other words, commercial vessels would be going there anyway as part of their routine operations to take on fuel. While doing so, it would be easy for the vessels to be offloading sewage. It is important to remember that it is not necessary for a vessel to empty its holding tank at one time. The system works even if a vessel only offloads some of its holding tank's contents during the time it takes to fuel up. In addition to upgrading the wet-well pumps, we would recommend the installation of a second shoreside pumpout system at the Mystic Marine site so that smaller commercial vessels not fitted with onboard pumps would also be able to pumpout at this location without interfering with the recreational pumpout operations.

BTT's site at 400 Border Street caters to the tugboats operating within the Harbor, visiting tugs and visiting larger commercial vessels. It is envisaged that this would continue and that the development of the site for commercial pumpout would address the sewage coming from the more industrial commercial vessels within the Harbor. We would not envisage recreational or smaller commercial vessels accessing this site and would therefore not recommend that a shoreside system be installed here.

### ***Specifics of Wet-well / Catch Basin Pumps***

The wet-well at Mystic Marine was equipped with two ABS Piranha<sup>®</sup> pumps to lift the sewage into the BWSC system. These pumps have had a history of failure. Passengers have been known to dispose of items such as plastic spoons etc. in the onboard heads. If these run through a pump they can lead to its failure. This was thought to be the problem as such items were found in the Moran Terminal wet-well from which the sewage is pumped into the municipal sewer system. If this were the cause of the repeated problems, it would be necessary to have macerating or grinder pumps that break any solid down into small pieces that will not cause problems. The specifications of such pumps would depend on how high the sewage needs to be lifted and the rate at which it needs to flow. However, a report by Web Engineering Associates to Massport (August 2000) suggests that the original ABS pumps that were installed were below specification and poorly maintained. This led to cavitation within the pumps, as well as peak

power output issues, and these are thought to be what caused them to fail. As it is clear that such systems need to be maintained, the scope of this study included a preliminary assessment of who would be responsible for the Operation and Maintenance (O&M) plans for the commercial pumpouts. Both Dennis Kraez of Diversified Automotive, and Phil Chase of Boston Towing and Transportation have agreed that if a commercial pumpout were to be located on their site, their companies would assume responsibility for implementing the O&M plan.

While maceration may still be an option, Web Engineering states that few macerating pumps are installed inline at a single end use. Most are installed within the wet-wells themselves. This is not the design of the Moran Terminal wet-well.

Their “best-engineering practice” solution is to upgrade the two existing pumps so that they conform to the requirements for the system. The cost of purchase and installation is estimated at \$9,000 to \$13,000 for the two. However, it may be feasible to also add an in-line macerator at the boat-pumpout facility itself (rather than in the wet-well). This would cost an estimated \$12,000 to \$16,000. It is likely that BTT’s site at 400 Border Street would require a similar system if it is not to run into the same problems as occurred at Mystic Marine. However, the Moran Terminal wet-well receives sewage from a number of local businesses and facilities. This would not be the case at the 400 Border Street site as the catch basin there would only receive boat sewage and would probably not require such powerful pumps.

Clearly, a more accurate cost estimate can only be achieved when a full engineering assessment can be completed. This was not part of the scope for this study. Until such an assessment is undertaken, it is not possible to ascertain if there will be any engineering complications or what the pump requirements would be needed. At Mystic Marine the sewer line connecting the manifold to the wet-well was in use until June 2000, at which point Massport prohibited commercial pumpout activity. However, it is probably safe to assume that the sewer line is still in an operational state. At 400 Border Street, it is less easy to ascertain this and structural problems may become apparent when full surveys are completed.

### *Types of Sewage Pumps*

There are numerous pumps on the market that are capable of handling sewage. Many of the more powerful can easily shred any solids that may be in the effluent. The exact specification will vary depending on the average and peak flow rates and the height, or “head”, to which the sewage must be lifted. For example in 1989, it was calculated that at the Moran Terminal wet-well flow rates would be 17-gpm average and 85-gpm peak. This was predicted to rise to 25-gpm average and 125-gpm peak in the future. However, future flow rates will depend on the development that occurs in the area and how many new businesses tie into the system (and therefore the increase in the numbers of people loading the system).

Below are some brief descriptions of three pumps that ABS currently markets (Figure 7): The Piranha<sup>®</sup> pumps are the slowest of the three and are described as a “sewage pump with shredding action used for reliable and economical discharge of effluent under pressure, using small diameter discharge lines...”. They can handle flow up to 140-gpm and can pump to a head of 260 feet. Further details are in the Appendix 1.

The ACP Chopper pump is faster and is described as “rugged, reliable ABS submersible pumps from 3 to 10.5KW for pumping debris laden wastewater, sewage treatment sludge, agricultural effluent, industrial and institutional wastewater and for all types of tough applications. The Chopper hydraulics incorporate an effective cutting and chopping system. The cutting rate is a staggering 8000 times per minute. Chopper is fitted with standard ABS submersible motors. Shaft sealing between motor and hydraulics utilizes high quality shielded silicon carbide

mechanical seals” (<http://www.abspumps.com/>). Flow rates vary from 0 to 1100gpm and the head is 5 to 57 feet. Full details can be found in the Appendix 1.

An even faster ABS pump is the Z6000. This is a “well-proven submersible... pump range for industrial water and waste applications. The modular construction system for Z6000 pumps permits each pump size to be combined with several motor sizes. They are suitable for wet- or dry-pit applications. Sturdy construction with two high-quality compact mechanical shaft-seals shorten impeller overhang, thus minimizing shaft deflection”. They have a maximum flow rate of 13,000-gpm and a maximum head of 200 feet.



FIGURE 7. The ACP Chopper Pump (left), the Piranha® (center) and the Z600 (right) produced by ABS. Photographs from the ABS website (<http://www.abspumps.com/>)

These are just three of the pumps that ABS markets and each can come in a number of motor sizes. As it seems that the pumps that were originally fitted in the Moran Terminal wet-well were not up to the specification, it is clear that if new pumps are to be fitted at both Mystic Marine and 400 Border Street, a significant amount of the engineering that will be required will have to focus on ensuring that suitable pumps are selected. This will occur during the full design and construction phase that, it is hoped, will occur in 2004.

### ***Specifics of Shoreside Pumpout Units***

Currently, Mystic Marine is equipped with a Waubashene LD125 shoreside sewage pumpout system. This consists of a 125-gallon tank and a two-way pump. This is a vacuum pump that sucks the sewage out of a vessel and into the tank. When the tank is full, it automatically switches to discharge mode. At this point the sewage is discharged down 985-foot of 8” sewer line to the Moran Terminal wet-well. Shoreside pumpout systems do not normally require macerators as recreational and small commercial vessels have a reduced likelihood of their sewage containing non-sewage solids (this problem is most common on ferries). While Mystic Marine is already equipped with a pumpout system, it is felt that a second unit would be advisable. This would allow for Mystic Marine to pumpout the smaller commercial vessels and still cope with the demands of the recreational boaters. It also provides redundancy in that if one unit is down for maintenance, pumpout services can continue. As it is felt that 400 Border Street is likely to cater more to the tug business and some of the larger commercial vessels, no shoreside pumpout system would be required at this site.

Various people who were interviewed recommend Edson Pumps as a reliable supplier of shoreside pumpout equipment. Edson are based in New Bedford MA. They offer diaphragm

vacuum and peristaltic pumpout systems (Figure 8). Each of these systems can be tied directly into a sewer line. Each of the systems has pros and cons.

The diaphragm system is the cheapest system, is easy to maintain, handles solids well and pumps at 38 gallons per minute. However, the system only has a static suction lift to 12 feet and a static discharge head of 15 feet (these terms are explained in Figure 9 but relate to the height to which the pumps can move the sewage). This may not be effective at the Mystic Marine site due to the height of the pier.

The vacuum system is moderately priced, pumps at 40 gallons per minute, is capable of handling solids and has a static suction lift of 25 feet and a 20-foot static discharge head, which would be sufficient for the Mystic Marine site. As a vacuum pump is designed to pump air, the system is not affected if there are leaks within the system. The drawback of this system is that it is a more complicated system that requires maintenance to ensure continued operation.

The peristaltic system is the most powerful with a static suction lift to 27 feet and 65-foot static discharge head. It pumps at 40 gallons per minute and is very reliable. However, this system can only handle solids up to 5/8 inch in diameter.

An engineer from Edson Pumps recommends the vacuum system if commercial vessels are to be pumped out due to the increased likelihood of the holding tank containing non-sewage solids such as bottle caps and plastic items. The vacuum system also means that it is possible to have three separate boat hook-ups from one pump, therefore allowing three vessels to be pumped out at one time.

Full details of these three systems are contained in the Appendix 2.

Which particular pumpout design would be more suitable will depend on the site chosen, and in particular on the height of the dock. Clearly, it is essential that any system that is chosen can function at all times in the tidal cycle, including at low water on a Spring tide.



FIGURE 8. The Edson diaphragm system (left), the vacuum system (center) and the peristaltic system (right). Photographs from the website of the Edson Pump Division based in New Bedford MA (<http://www.edsonpumps.com/>)

Generally, commercial vessels may be expected to be larger than recreational vessels and, depending on the activities in which they are involved, they may also have larger holding tanks. It is therefore recommended that the new shoreside pumpout system be one that ties directly into the sewer line and therefore removes the necessity for a shoreside holding tank. In this way, the system does not have a limited capacity to hold sewage before the system must discharge into the sewer line. A direct hook-up to the sewer line would mean that vessels with large holding tanks could still be catered to.

The costs of shoreside pumpout systems vary between \$4,000 and \$15,000. This does not include the cost of installation. Depending on the situation and level of difficulty, installation can add an additional \$8,000 to \$30,000 to the cost (estimate from Edson Pumps engineer). The installation costs at Mystic Marine are not expected to be so significant as a sewer line already services the existing Waubashene system that is in place. However, this can only be ascertained when a full engineering survey has been undertaken, which will hopefully occur in the next phase of this project.

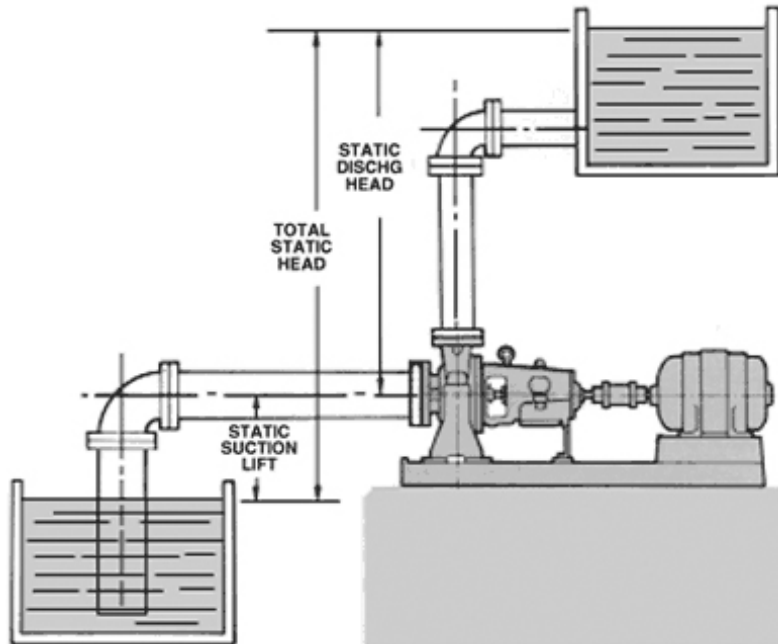

FIGURE 9. Diagram describing how the static suction lift and the static discharge head relate to the function of a pump. Taken from the Goulds Pumps website (<http://www.gouldspumps.com/>)



## PRELIMINARY COST ESTIMATES FOR THE DEVELOPMENT OF THE TWO SELECTED SITES

As discussed earlier, at this stage of the project to establish a City of Boston-sponsored commercial pumpout facility, or facilities, it is only possible to provide a preliminary estimate as to the costs. This is largely due to the fact that in order to implement such an undertaking, a considerable amount of engineering survey work will be required and such work may uncover structural, mechanical or electrical issues that would increase the costs significantly. It is clear that when the pumps were installed in the Moran Terminal wet-well, they were below specification and this led to major follow-up costs as the pumps needed to be replaced. It is therefore essential that the same mistake is not made with the establishment of the commercial pumpout facilities in Boston Harbor. Engineers will have to assess what pumps are needed to cope with the current flow rates and also to predict what future flow rates may be so that the system does not become redundant if further development occurs at either site that leads to an increase in the loading on the systems.

It is expected that engineering expertise will be required to ascertain:

- The structural integrity of existing pumpout sewer lines.
- The structural integrity of existing municipal sewer pipes, including the connections between the pumpout sewer lines and the municipal system.
- The structural integrity of all docks and piers at which vessel may tie up for pumpout (including the pilings and dock cleats etc.).
- Water depth at the piers at both locations and whether or not dredging would be necessary.
- The structural integrity of the catch basins / wet-wells at both sites.
- The status of dockside sewer discharge pipe manifolds.
- The specifications of the pumps required at both sites, taking into account possible future increases in loading.
- The status of the electrical supplies at each site to ensure that they are capable of dealing with the extra load from the pumps.
- Whether or not macerators should be incorporated into the designs.
- The exact specifications of a shoreside pumpout system at Mystic Marine based on the head through which the sewage must be lifted and the expected volumes and rates at which it must flow.
- Sufficient access to the systems to allow for maintenance / repair.
- The best location of dockside sewer lines, if not already in situ, to ensure that they are protected from the elements so that any residual effluent does not freeze during the winter and block the system.

If the engineering surveys uncover any issues that would significantly increase the costs of establishing either of the two commercial pumpout facilities, such as the need to rebuild a dock or carry out extensive dredging, it would be necessary to rethink the site selection.

Assuming that no major issues are identified during the next phase, and from discussions with engineers and operators, the costs of establishing a pumpout facility at both Mystic Marine (direct sewer line hook-up and shoreside pumpout) and 400 Border Street (direct sewer line hook-up only) would cost between \$40,000 and \$126,000 (Table 6). The reasons that the

estimates range so significantly is that there are a number of options as to the type of shoreside pumpout, the necessary specification for wet-well / catch basin pumps and whether or not macerators would be required. These questions would be answered as part of the engineering assessment in the next phase.

TABLE 6. Estimated costs of equipment and installation at the two selected sites

<b>MYSTIC MARINE</b>				
Item	Price Range			Comments
2x ABS Pumps for wet-well	\$9,000	to	\$12,000	Purchase and installation based on estimates from Web Engineering
Macerating pump	\$12,000	to	\$16,000	Purchase and installation based on estimates from Web Engineering (only if required)
Shoreside Pumpout System	\$4,000	to	\$15,000	Purchase only, based on estimates from Edson Pumps
Installation	\$8,000	to	\$25,000	Based on estimates from Edson Pumps

<b>400 BORDER STREET</b>				
Item	Price Range			Comments
2x ABS Pumps for wet-well	\$9,000	to	\$12,000	Purchase and installation based on estimates from Web Engineering
Macerating pump	\$12,000	to	\$16,000	Purchase and installation based on estimates from Web Engineering (only if required)

<b>BOTH SITES</b>				
Item	Price Range			Comments
Engineering Assessment	\$10,000	to	\$30,000	Assessment for shoreside sewer lines, pumps, pier structural integrity and electrics
Engineering Assessment	Free			Assessment for installation of Edson shoreside pumpout system is free from the company

<b>BOTH SITES</b>				
	Minimum		Maximum	
<b>TOTAL</b>	<b>\$64,000</b>		<b>\$126,000</b>	including Macerating pump
	<b>\$40,000</b>		<b>\$94,000</b>	excluding Macerating pump

## OPERATION AND MAINTENANCE

Both Dennis Kraez (Diversified Automotive/Mystic Marine) and Phil Chase (Boston Towing and Transportation) have expressed great interest in operating a commercial pumpout facility. It is envisaged that their organizations would assume full responsibility for the Operation and Maintenance (O&M) of the equipment that would be installed on their properties and ensuring that the systems remained operational.

As discussed previously, the pumpout systems will differ between the two sites and, as a result of this, so will the maintenance obligations. Mystic Marine would be equipped with both a shoreside pumpout and a direct hook-up to the sewer line for larger vessels, while Border Street would only have a direct hook-up. Direct hook-ups themselves require little regular maintenance apart from ensuring that the sewer line does not become blocked or frozen. However, both sites would require pumps in the wet-wells or catch basins. These pumps would require annual servicing to ensure that they remained operational and to ensure that their operational life-spans were not reduced. Regular maintenance is not expected to be costly, although the exact costs will depend on what make and type of pumps are installed.

Shoreside pumpout systems also require regular maintenance but, due to their higher degree of complexity, this must occur on a more frequent basis. The different types of shoreside systems require varying levels of maintenance and have various operational specifications. When the choice is being made as to which system to install at Mystic Marine, it will be necessary to balance the required specifications and the maintenance requirements. However, the suggestion that an Edson system be used is based on the fact that they are reported to be reliable and that Edson is located in New Bedford MA. The close proximity of the manufacturer means that if problems do arise, they can be quickly addressed by Edson service personnel.

Although shoreside pumpout systems require more maintenance, much of this is not complex and does not require extensive training. Research into pumpout operations conducted by the Urban Harbors Institute in 2002 and 2003 suggests that annual maintenance costs for a shoreside system range from \$100 to \$1,500.

PRELIMINARY SITE PLANS FOR THE TWO SELECTED SITES

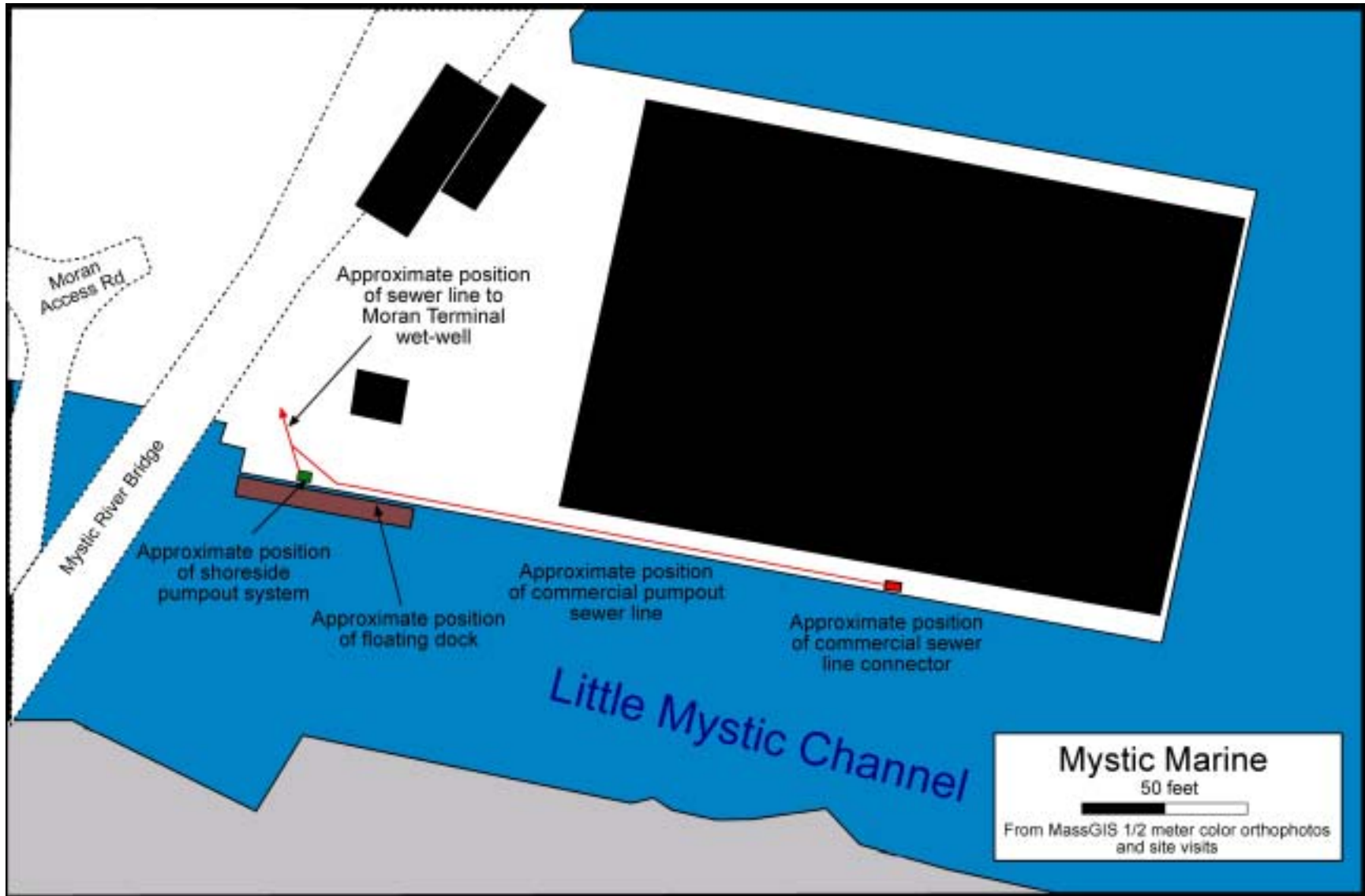



## APPENDIX 1: SPECIFICATIONS OF ABS PUMPS

## PIRANHA<sup>®</sup> 08

Small Grinder pump for use in the pumping of domestic sewage using the well proven Piranha cutting system. Also ideal for high head applications in clean water.

60Hz

- Unique ABS patented Piranha shredding system capable of shredding domestic waste.
- Suitable where the static lift is high or pumping sewage on undulating terrain.
- Suitable for individual households (to a maximum of three).
- Built-in temperature limiter.
- Available with or without KS Float switch.
- Advantage of small discharge lines from G1<sup>1</sup>/<sub>4</sub>" (DN 32).
- Simple cost effective installation.
- No control panel required.
- Head to 30m.



# PIRANHA 08

Technical Data		Discharge Internal thread		Motor Power P <sub>1</sub> HP P <sub>2</sub> kW		Speed at 60 Hz		Rated voltage V		Rated current A		Cable Type 10 m		Weight kg/lbs.	
Piranha 08 W		1 1/4"		2,6 1,4		3450		230		8,38		16/3 SJTOW-A		14/30	
Piranha 08 D		1 1/4"		5,2 1,2		3450		460		5,4		16/3 SJTOW-A		14/30	
*P <sub>1</sub> = Power taken from mains; P <sub>2</sub> = Power at motor shaft															
<b>Head</b>	<b>H [m]</b>	4	6	8	10	12	14	16	18	20	22	24	26	28	30
<b>Flow</b>	<b>Q [l/sec]</b>	2,2	2,1	2	1,9	1,8	1,7	1,5	1,3	1,2	1	0,8	0,6	0,4	0

## Data, Dimensions and Accessories

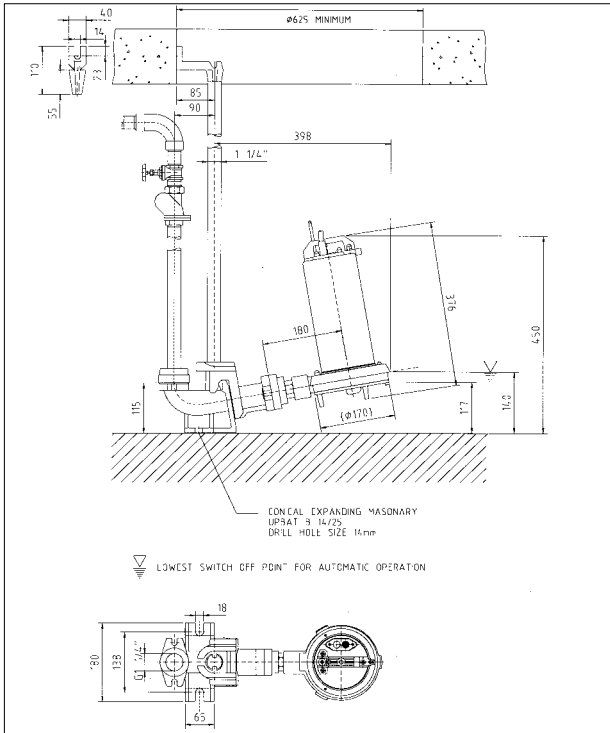

### Accessories

#### Fixed Installation with Pedestal

Description (Material)	Size	Part No.
<b>PIRANHA 08</b>		
○ Pedestal (GG-25)	PIRANHA08	62325007
G 1 1/4", supplied complete with fixing bolts		

## High head roof water storage application

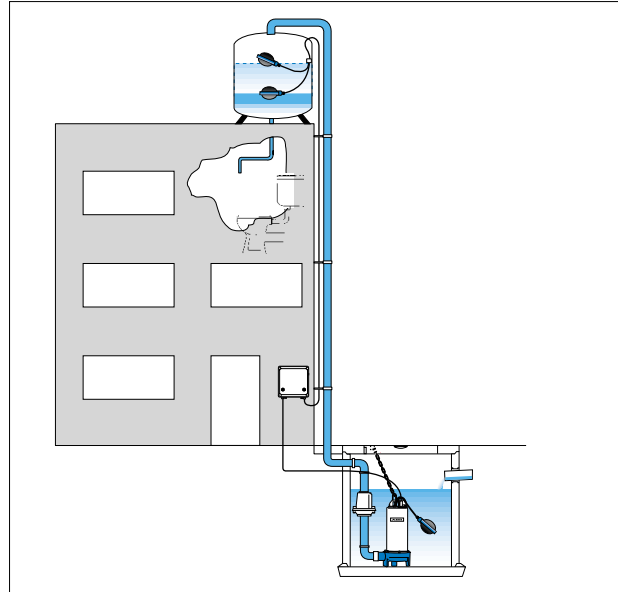

Description (Material)	Size	Part No.
○ Adaptor		13770011
○ Guide tube (steel, galv.)	1 1/4"	1 m 31380007 2 m 31380008 3 m 31380009 4 m 31380010 5 m 31380011
○ Chain (steel, galv.) with shackle		m 14990002 + 14990008
○ Ball type non-return valve (GG-25) with 2 x internal thread	G 1 1/4"	61400525
○ Shut off valve (brass) with internal thread	G 1 1/4"	14040005

**ABS**  
COST-EFFECTIVE PUMPING

ABS reserves the right to alter specifications due to technical developments

**Austria:**  
Tel. +43 2236 642 61/65  
Fax +43 2236 642 66

**Estonia:**  
Tel. +372 656 3398  
Fax +372 656 3385

**Greece:**  
Tel. +30 1 95 32 501  
Fax +30 1 95 32 504

**Norway:**  
Tel. +47 67 554 700  
Fax +47 67 554 750

**Sweden:**  
Tel. +46 31 706 16 00  
Fax +46 31 27 29 20

**Agents and distributors**  
ABS has sales and service representatives in more than 100 countries the world over

**Belgium:**  
Tel. +32 2 725 79 00  
Fax +32 2 725 71 19

**Finland:**  
Tel. +358 9 506 88 90  
Fax +358 9 55 80 53

**Hungary:**  
Tel. +36 1 231 60 70  
Fax +36 1 231 60 80

**Poland:**  
Tel. +48 22 63 38 646  
Fax +48 22 63 38 644

**Switzerland:**  
Tel. +41 71 694 6555  
Fax +41 71 694 6556

[www.abspumps.com](http://www.abspumps.com)

**Brazil:**  
Tel. +55 41 348 1991  
Fax +55 41 348 1879

**France:**  
Tel. +33 1 49 35 24 50  
Fax +33 1 48 54 42 82

**Ireland:**  
Tel. +353 53 63 200  
Fax +353 53 46 006

**Singapore:**  
Tel. +65 46 33 933  
Fax +65 46 22 122

**Turkey:**  
Tel. +90 216 455 2256  
Fax +90 216 455 2265

ABS is a company in the Cardo Group

**Canada:**  
Tel. +1 905 670 4677  
Fax +1 905 670 3709

**Germany:**  
Tel. +49 2246 13 0  
Fax +49 2246 13 200  
Tel. +49 6257 93 17 0  
Fax +49 6257 93 17 99

**Italy:**  
Tel. +39 051 89 00 911  
Fax +39 051 86 18 48

**South Africa:**  
Tel. +27 11 397 1612  
Fax +27 11 397 1795

**U.S.A.:**  
Tel. +1 203 238 2700  
Fax +1 203 238 0738

**Denmark:**  
Tel. +45 48 17 11 10  
Fax +45 48 17 19 11

**The Netherlands:**  
Tel. +31 43 352 50 50  
Fax +31 43 363 33 95

**Great Britain:**  
Tel. +44 1293 74 48 00  
Fax +44 1293 54 3 92

**Spain:**  
Tel. +34 91 670.28.51  
Tel. +34 91 666 58 68

**All other countries:**  
ABS Pumps International  
Head Office, Sweden  
Tel. +46 31 83 63 00  
Fax +46 31 16 79 14

Part No. 16005218



## AFP 1062 to 1562 Chopper Pump

Rugged, reliable submersible pumps from 3 to 11 kW for pumping debris laden wastewater, sewage treatment plant sludge, agricultural effluent, industrial and institutional wastewater and for all types of tough applications

DN 100 and DN 150

- For pumping stations in public and institutional facilities
- For excess sludge sumps in sewage treatment plants
- The AFP Chopper provides trouble free operation in woodyard sumps (bark and dirt from a log yard)
- The AFP Chopper is ideally suited for waste handling in all types of food processing
- Also suited for waste handling in rendering operations
- Automatic seal and temperature monitoring
- Fitted with standard ABS submersible motors
- Ideal for pumping farmyard slurry and run-off



## Applications

AFP Chopper pumps have been designed for those particularly difficult applications where standard pumps have difficulty coping.

In certain applications the sewage is a problem as all kinds of objects both fibrous and solid get flushed down the toilet.

The AFP Chopper hydraulics incorporate an effective cutting and chopping system which can deal effectively with otherwise difficult liquids such as sewage from institutions e.g. prisons and hospitals, sewage from train stations and sewage and run off from a large variety of processing and industrial applications including abattoirs, fish plants, factory fishing boats, wood processing etc. They are also used in agricultural applications involving straw and liquid manure.

They can be mounted on the standard ABS single guide rail pedestals or used free standing on a skirt base. Accessories are also available for installations in agricultural applications for mixing, circulation and pumping.

## Cutting system

The cutting system of the AFP chopper pumps consists of a special hardened and sharpened impeller and cutter plate. The cutter plate has cutting "pockets" which act as a shears. These cut up a variety of objects into a short pumpable size. The cutting rate is a staggering 8000 times per minute!

The impeller is fitted with a screw type auger, which draws the objects to be chopped into the hydraulics. This is especially effective in pumping sludge and in agricultural applications.

## Motor construction

AFP Chopper submersible pumps are compact watertight integral construction units with short robust shafts mounted in lubricated for life bearings.

Shaft sealing between motor and hydraulics utilises high quality silicon carbide mechanical seals. Protection against corrosive attack from liquid manure is achieved by careful selection of materials of construction using cast iron housings and stainless steel shaft and fasteners.

## Long life and minimum wear

Operating parts such as the impeller, volute and bottomplate are of high efficiency due to computer aided design and have proved themselves in the toughest practical tests.

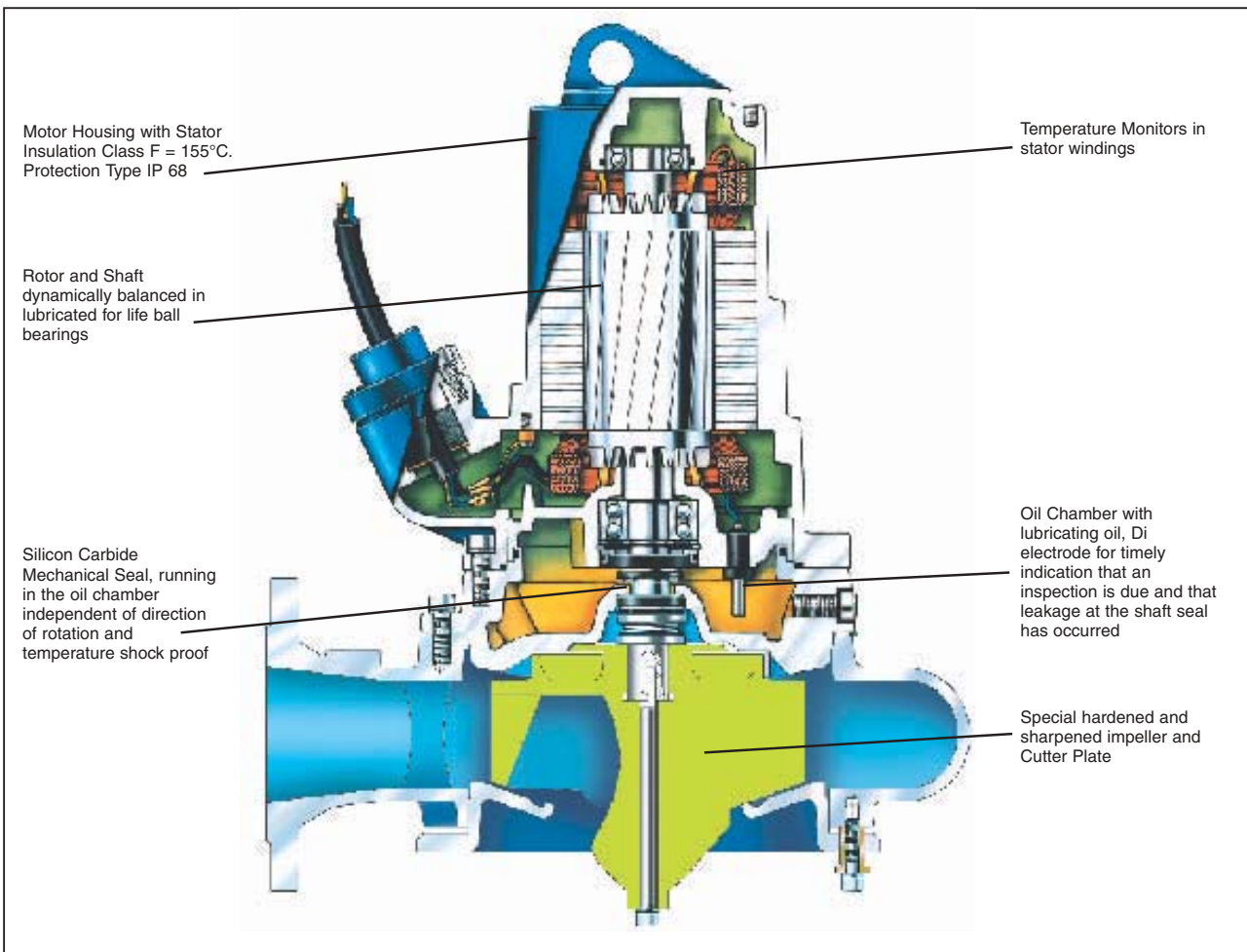



**PLASTIC BAGS, ARTICLES OF CLOTHING, SANITARY TOWELS, TIGHTS, CONDOMS, SYRINGES, CHILDREN'S TOYS ETC. ETC. ARE CHOPPED AND SWALLOWED BY THE AFP CHOPPER RANGE OF PUMPS**

AFP Chopper pumps have been designed for those extra difficult applications where standard pumps have difficulty coping.

We have all been confronted with certain applications where the sewage is a major problem because all kinds of objects both fibrous and solid get flushed down the toilet.

These are often institutional applications such as sewage from prisons, hospitals, mental homes and old people's homes. Locations used by large crowds of people such as train stations can also be a problem. Every city has a "difficult" application where special measures are needed. The AFP chopper pump is the answer.

The hydraulics incorporate an effective cutting and chopping system which makes short work of otherwise difficult applications. This can eliminate the need for expensive comminutors and pre-grinders.

**WHEN THE GOING GETS TOUGH THE TOUGH AFP CHOPPER PUMP GETS GOING**

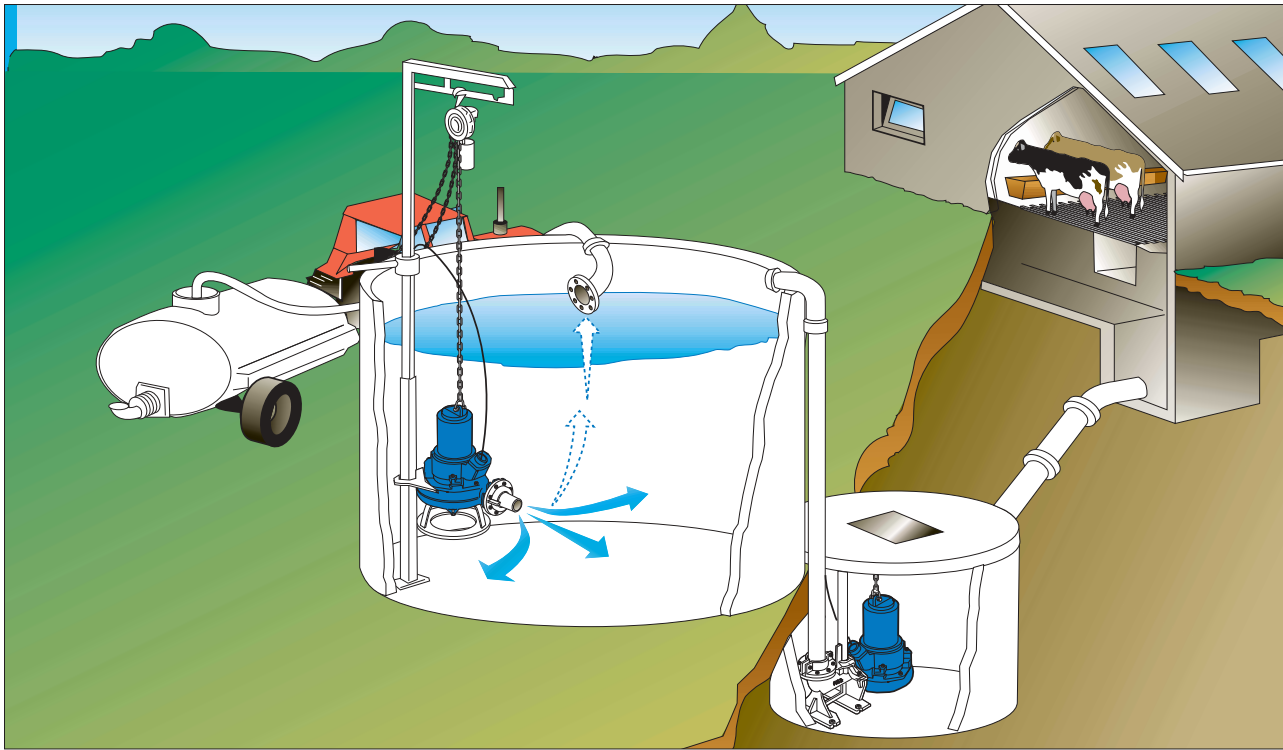

**Agricultural applications**

The AFP Chopper is ideal for tough agricultural applications.

The pump is fitted with a submersible motor, which is located below the liquid surface and thus protected from frost. There is no need for a tractor driving a PTO driven pump as the AFP Chopper pump has with a powerful electric motor with plenty of reserves.

Farmyard effluent and slurry contain solid and fibrous particles, which can block a conventional sewage pump. Straw for bedding, split animal feed plus the animal manure itself combine together to produce one of the most difficult pumping applications.

Regulations governing field spreading of slurry mean that the farmer has to store slurry until a suitable time for spreading arrives.

The AFP Chopper can pump the farmyard effluent to a holding tank. In addition the AFP Chopper can be used for mixing the contents of the holding tank and for pumping out the contents to a slurry tanker or for field spreading.

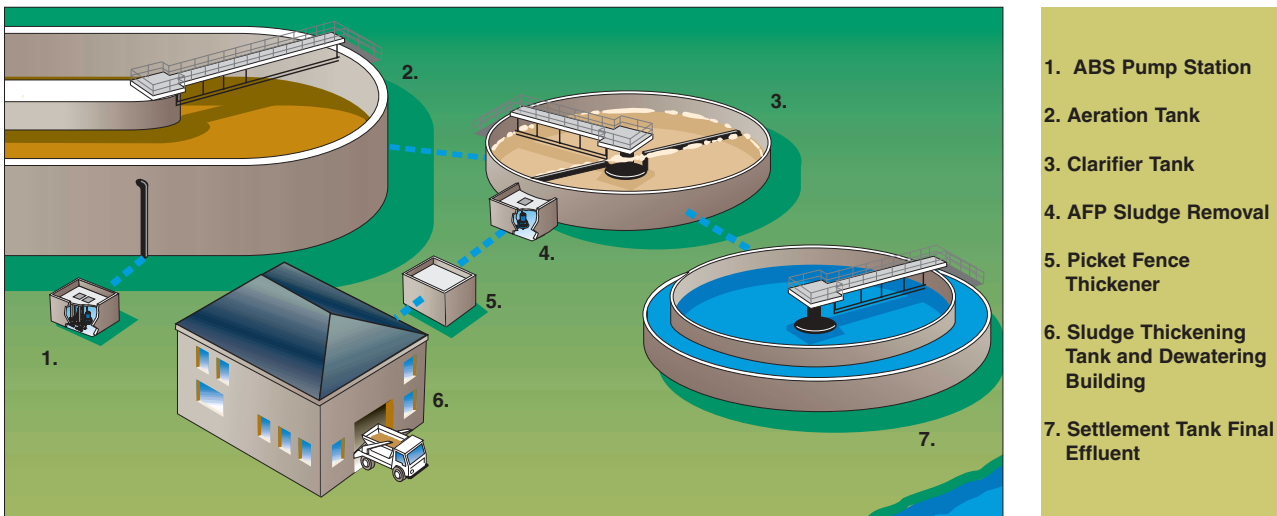

**Sludge pumping:**

The pumping of sludge is a critical part of the operation of a sewage treatment plant. Sludge has the characteristics of having a higher solids content than normal municipal sewage plus the presence of “roping” which can occur during the process. The auger feeding screw at the impeller helps draw the sludge into the pump where it is chopped and pumped on.

**Digester scum blankets:**

The AFP Chopper pump mixes scum blankets and prevents them from reforming.

**Digester recirculation**

The AFP Chopper pumps recirculate in an effective manner the digester sludge through heat exchangers. this can eliminate the need for comminutors.

***The AFP Chopper pump is the perfect solution for chopping and pumping of solids and is used widely in the following applications***

*The AFP Chopper pump is used in various types of fish processing industries ranging from the processing applications on dry land to the processing on trawlers at sea.*

**FISH HEADS, BONES, FISH PROCESSING WASTE OF ALL TYPES**



*The AFP Chopper pump is widely used in agriculture and can give free agitation or pump into a pipeline. It can be fitted for recirculation or flushing systems.*

**LIQUID MANURE HANDLING, COLLECTION PITS, HIGH LEVEL SILO**



*The AFP Chopper pump provides trouble free operation for the wood products and pump and paper industry*

**WOODYARD SUMPS, LOG SOAKING VATS, BARK HANDLING, DRAINAGE SUMPS, COAL PILE RUNOFF**



*The AFP Chopper pump is also suitable for waste handling in rendering operations. All types of rendered solids are handled successfully such as*  
**BLOOD, BONES, FAT, HAIR, FLESHINGS, PIECES OF HIDE, OFFAL, HORNS, HOOVES, EARS**



*The AFP Chopper pump is also suitable for waste handling in all types of food processing. Food processing industries such as restaurants, poultry, pork, fruit and vegetables have benefited from the excellent solids handling ability of the AFP chopper pump.*

**BLOOD, BONES, POULTRY FEATHERS, WHOLE CHICKENS, CARROTS, POTATOES**



## Performance Ranges 50 Hz

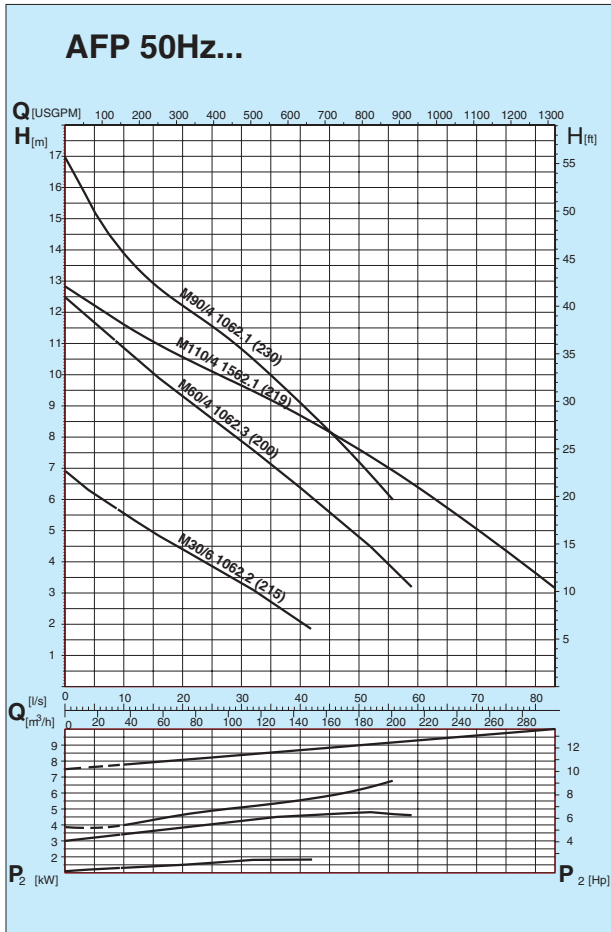

## Performance Ranges 60 Hz

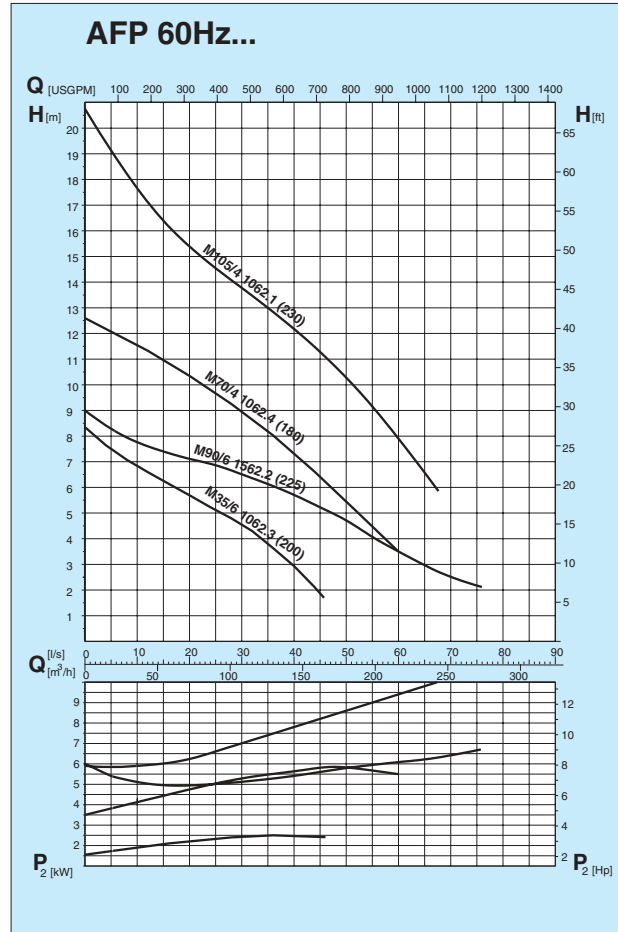

Solids passage 1062 DN 100/4" – 50 mm (2")  
1562 DN 150/6" – 65 mm (2<sup>5</sup>/<sub>8</sub>")

Technical Data														
Hydraulics	Dis-charge DN/ins.	50 Hz 60 Hz version	Motor	Motor Power*			Speed min <sup>-1</sup>	Rated Voltage				Cable Type** Starting	Weight kg/lbs.	
				P <sub>1</sub> kW	P <sub>2</sub> kW	P <sub>2</sub> HP		V/A	V/A	V/A	V/A			
AFP 1062.1	100/4"	50	M90/4	10,8	9	12	1480	400	19,4	(1)	Star Delta	133/293		
AFP 1062.2	100/4"	50	M30/6	4,1	3	4	960	400	7,7	(1)	Star Delta	115/253		
AFP 1062.3	100/4"	50	M60/4	7,2	6	8	1480	400	12,5	(1)	Star Delta	123/271		
AFP 1562.1	150/6"	50	M110/4	12,9	11	15	1480	400	23,1	(2)	Star Delta	255/561		
								V/A	V/A	V/A	V/A			
								230	380	460	575			
AFP 1062.1	100/4"	60	M105/4	12,4	10,5	14	1780	38,3	23,2	19,2	15,4	(1)	Star Delta	133/293
AFP 1062.3	100/4"	60	M35/6	4,6	3,5	4,7	1150	15,4	9,3	7,6	6,1	(1)	Star Delta	115/253
AFP 1062.4	100/4"	60	M70/4	8,4	7,0	9,5	1780	24,6	14,9	12,3	9,7	(1)	Star Delta	123/271
AFP 1562.2	150/6"	60	M90/6	10,5	9	12	1150	39,3	23,8	19,6	15,7	(2)	Star Delta	255/561

\*P<sub>1</sub> = Power taken from mains; P<sub>2</sub> = Power at motor shaft

\*\*Cable type: Special rubber for Submersible Pumps  
(1) 10 x 1.5 mm<sup>2</sup> – 400V  
(2) 10 x 2.5 mm<sup>2</sup> – 380/460/575V, Twin 4G4 + 2 x 0,75 – 230V

### Dimensions mm

### AFP (1062) 1562

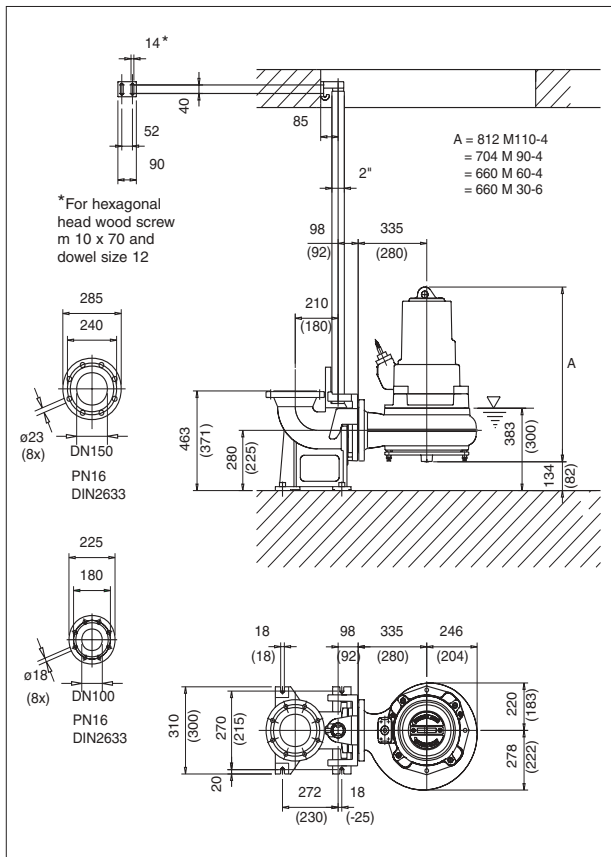

### Dimensions mm

### AFP (1062) 1562

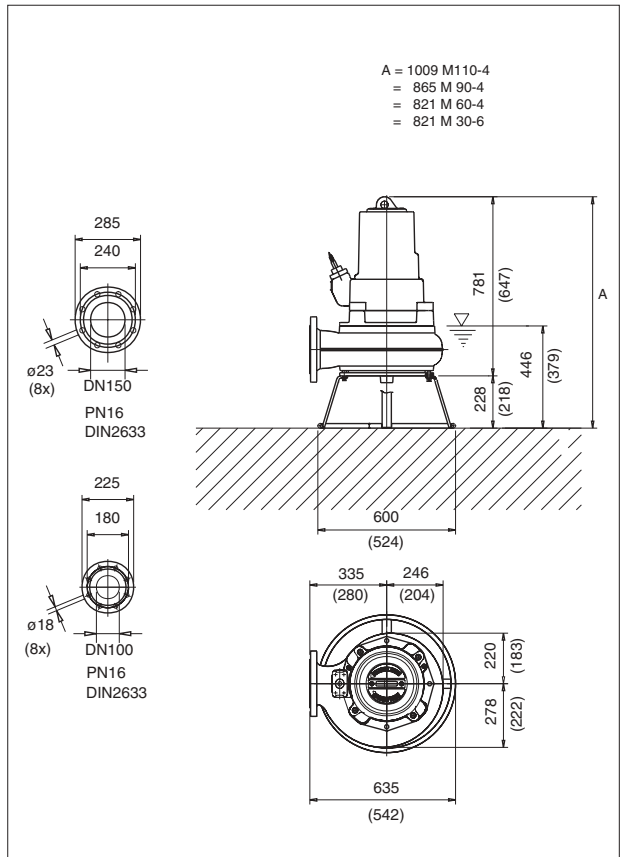

### Dimensions (Inches)

### AFP (1062) 1562

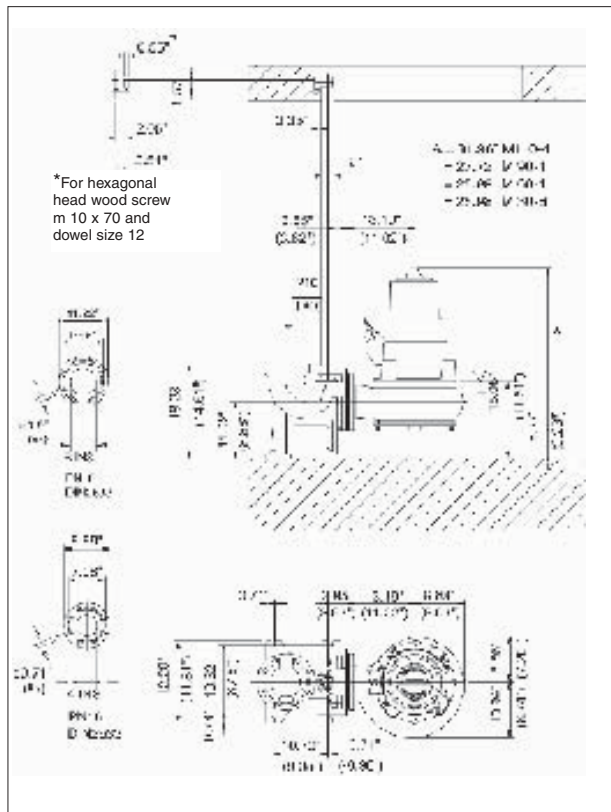

### Dimensions (Inches)

### AFP (1062) 1562

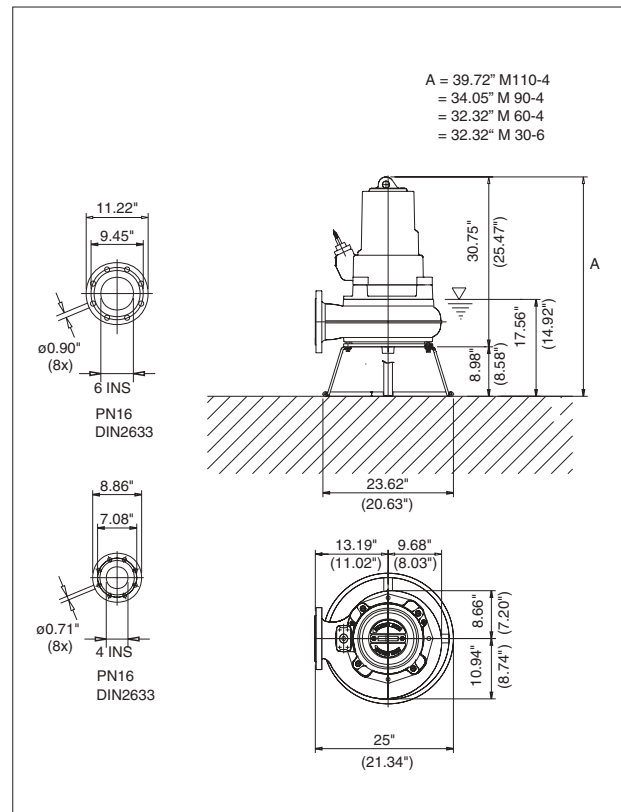

## Accessories

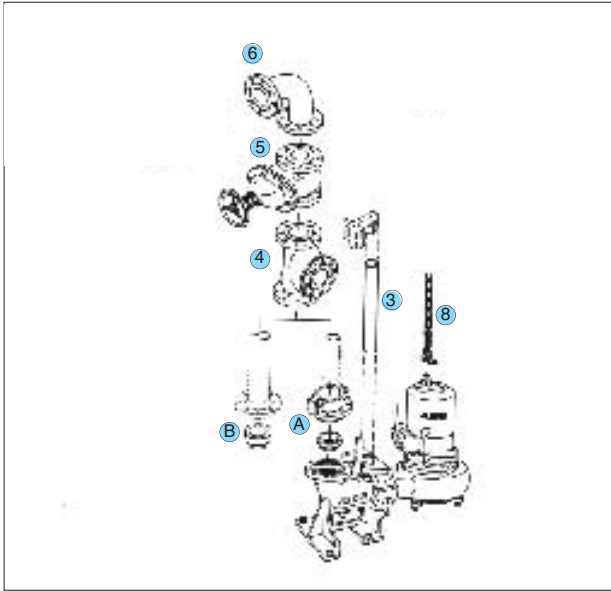

Description (Material)	Size	Part No.
① <b>Pedestal with cast on 90° Bend</b> (GG-25 cast iron) for ABS Automatic Coupling System with:		
Ⓐ Plug/clamp connection for discharge pipe	A-ø 109 mm DN 100	6 232 0653
	A-ø 115 mm DN 100	6 232 0654
	A-ø 160 mm DN 150	6 232 0656
	A-ø 169 mm DN 150	6 232 0657
Ⓑ with DIN or ASA flange connection	ASA 4" DN 100	6 232 0665
	ASA 6"/DN 150	6 232 0652
③ <b>Guide tube</b> (steel, galv.)	2" 1 m	3 138 0001
	2 m	3 138 0002
	3 m	3 138 0003
also:	4 m	3 138 0004
Pipe connector with securing pins for guide tube length above 6 m	5 m	3 138 0005
	6 m	3 138 0006

○ **Discharge pipe** on request, please give DN and L

Description (Material)	Size	Part No.
④ <b>Ball type non-return valve</b> (GG-20) with inspection opening and venting mechanism including 1 set of bolts and 1 gasket, flanges to PN 16	DN 100	6 140 0535
	DN 150	6 140 0518
⑤ <b>Gate valve</b> (GG-20 cast iron) including hand wheel, 1 set of bolts and 1 gasket, flanges to PN 16	DN 100	6 142 0501
	DN 150	6 142 0503
⑥ <b>90° Bend, Q-piece,</b> (SG iron to DIN 28637)	DN 100	6 261 0303
	DN 150	6 261 0305
⑦ <b>Junction piece</b> (St. 37 steel) to join the two discharge lines in the case of a twin-pump station	DN 100/100/100	6 261 0003
	DN 100/150/100	6 261 0005
	DN 150/150/150	6 261 0006
	DN 1 80 100 100 150	
	DN 2 100 100 150 150	
	A 460 580 580 860	
	H 165 200 200 270	
	L 260 195 330 270	
⑧ <b>Chain</b> (steel, galv.) including shackle	m 1 499 0002	
		+ 1 499 0008
⑨ <b>Sump cover</b> (St. 37 steel) with frame and seal	500x 500 mm	1 499 0051
	700x 700 mm	1 499 0052
	700x1400 mm	1 499 0053
<b>Sliding Bracket</b> Stainless Steel	1062	4 142 5042
	1562	4 142 5043
<b>Nozzle</b> Stainless Steel	1062	4 317 5000
	1562	4 317 5001

ABS reserves the right to alter specifications due to technical developments

**ABS**  
COST-EFFECTIVE PUMPING

**Austria:**  
Tel. +43 2236 642 61/65  
Fax +43 2236 642 66

**Estonia:**  
Tel. +372 656 3398  
Fax +372 656 3385

**Greece:**  
Tel. +30 1 95 32 501  
Fax +30 1 95 32 504

**Norway:**  
Tel. +47 67 554 700  
Fax +47 67 554 750

**Sweden:**  
Tel. +46 31 706 16 00  
Fax +46 31 27 29 20

**Agents and distributors**  
ABS has sales and service representatives in more than 100 countries the world over

**Belgium:**  
Tel. +32 2 725 79 00  
Fax +32 2 725 71 19

**Finland:**  
Tel. +358 9 506 88 90  
Fax +358 9 55 80 53

**Hungary:**  
Tel. +36 1 231 60 70  
Fax +36 1 231 60 80

**Poland:**  
Tel. +48 22 63 38 646  
Fax +48 22 63 38 644

**Switzerland:**  
Tel. +41 71 694 6555  
Fax +41 71 694 6556

[www.abspumps.com](http://www.abspumps.com)

**Brazil:**  
Tel. +55 41 348 1991  
Fax +55 41 348 1879

**France:**  
Tel. +33 1 49 35 24 50  
Fax +33 1 48 54 42 82

**Ireland:**  
Tel. +353 53 63 200  
Fax +353 53 46 006

**Singapore:**  
Tel. +65 46 33 933  
Fax +65 46 22 122

**Turkey:**  
Tel. +90 216 455 2256  
Fax +90 216 455 2265

ABS is a company in the Cardo Group

**Canada:**  
Tel. +1 905 670 4677  
Fax +1 905 670 3709

**Germany:**  
Tel. +49 2246 13 0  
Fax +49 2246 13 200  
Tel. +49 6257 93 17 0  
Fax +49 6257 93 17 99

**Italy:**  
Tel. +39 051 89 00 911  
Fax +39 051 86 18 48

**South Africa:**  
Tel. +27 11 397 1612  
Fax +27 11 397 1795

**U.S.A.:**  
Tel. +1 203 238 2700  
Fax +1 203 238 0738

**Denmark:**  
Tel. +45 48 17 11 10  
Fax +45 48 17 19 11

**Great Britain:**  
Tel. +44 1293 74 48 00  
Fax +44 1293 54 33 92

**The Netherlands:**  
Tel. +31 43 352 50 50  
Fax +31 43 363 33 95

**Spain:**  
Tel. +34 91 670.28.51  
Tel. +34 91 666 58 68

**All other countries:**  
ABS Pumps International  
Head Office, Sweden  
Tel. +46 31 83 63 00  
Fax +46 31 16 79 14

Part No. 16005209



## APPENDIX 2 SPECIFICATIONS OF EDSON PUMPOUT SYSTEMS

# Edson BASIC ELECTRIC DIAPHRAGM PUMP OUT SYSTEM

## Bronze 40 GPM Diaphragm Pump & Pump Out Hose Assembly

### Performance Features

- No Clog, No Spill, No Smell
- Dry Start Suction Lift to 12ft (3.65m)
- Discharge Head 15ft (4.57m)
- Pump Rated to 38 GPM (144LPM)
- Dependable Performance
- Automatic Self Priming Starts

### Design Features

- Easy to Use-Low Maintenance Components
- Modular For Flexibility of Installation
- Pump - Bronze, 2" Diaphragm
- Motor - 3/4 HP, 1Ph, 120/240V for Convenient Installation
- Optional Motors & Controls For Any Requirements

**For Marine, Campground and Industrial Applications.** Edson's engineers have combined Edson Single Diaphragm Pump with the hose, fittings and accessories required to provide a trouble-free and efficient Sewage Collection System. The Edson Basic Diaphragm Pump Out will also provide industrial and commercial operations with an environmentally sound method of sewage, oil, and waste liquid collection.

At the "Heart" of the pump out is Edson's powerful diaphragm pump. It is the best choice for the transfer and collection of sewage, sludge, waste oil and high viscosity fluids with suspended solids under low head conditions. Straight-through passages with no impellers insure Edson Pumps will not be stopped or damaged by personal hygiene items, bottle caps, paper, stones, twigs, banana peels, or any materials encountered when collecting waste products.

For boat and truck mounted portable pump outs using a 3/4 HP 12 volt motor to power the pump is a very efficient use of energy and the quite on demand operation is preferred over gasoline power engine.



278EB-40

### Edson Diaphragm Pump Out Systems

**PUMP PERFORMANCE:** Max. Volume - 38GPM / 144 LPM ● Suction Lift - to 15 ft / 4.57m ● Discharge Head - to 15 ft / 4.57m ● Dry Suction Lift - 12 ft / 3.65m.

**PUMP CONSTRUCTION:** Marine Bronze Pump Body ● Nitrile Diaphragm and Valves ● Stainless Steel Hardware ● Aluminum Frame ● Inlet - 2" Male NPT ● Discharge - 2" Female NPT ● Standard Electric - 3/4 HP, Single Phase, 115/230 Volt, 8.4/4.2 Amp, 60 HZ, 55 RPM, TEFC Gearmotor

**PUMP OUT HOSE ASSEMBLY:** 1 1/2" Polyflex Hose ● 90° Ball Valve ● Sight Glass/Check Valve ● Quick Clamp Adapter ● Complete Set of Deck Adapters ● 25 ft Length Standard ● 50ft Optional

**OPTIONS:** 50' Hose Assembly ● Explosion Proof Motor ● Motors and Controls for Any Power Requirement ● Explosion Proof On/Off Switch ● Bronze Pump Out Hydrant 270BR-150

### ORDERING INFORMATION

DESCRIPTION <i>See Price List For Other Models</i>	WEIGHT (Lbs / Kgs)	ORDER NO.
Basic Diaphragm Pump Out System	250 / 112	278EB-40
Waste Hose Assembly	25 / 11.2	279WHA-200
Bronze Pump Out Hydrant 1 1/2"	35 / 15.7	270BR-150
Hose Stand Only	35 / 15.7	260-HS
Hose Stand With Stop Start Buttons	35 / 15.7	260-284

# Edson

146 Duchaine Blvd., New Bedford, MA 02745-1292

Tel. 508-995-9711 Fax 508-995-5021

INTERNATIONAL

E-Mail pumps@edsonintl.com

www.edsonpumps.com

## Edson Diaphragm Pump Out Systems 278EB-40

**Pump:** 3/4hp/1ph/115/230v/60hz/tefc gearmotor operating at 55 rpm and coupled to a 40 gpm bronze diaphragm pump. All arranged on a painted aluminum frame with 4 mounting flanges.

**Hose Assembly:** 25' X 1 1/2" Polyflex Hose, 90° Ball Valve, Sight Glass/Check Valve, Quick Clamp Adapter, Complete Set of Deck Adapters.fig.4

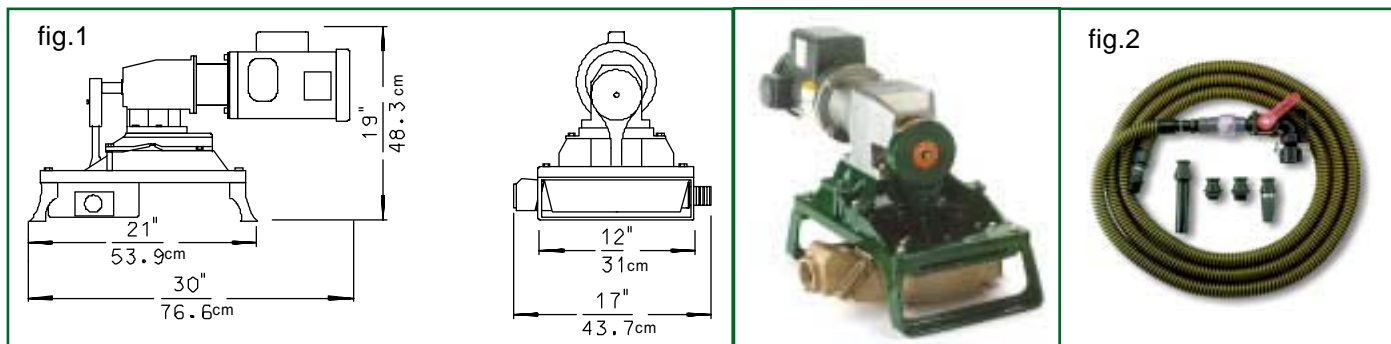

### Options

#### For Stationary Applications

**Hose Stand (Optional):** White Powder Coated Aluminum with or without Start & Stop Buttons Installed, Operation Instructions Sign and (4) 1/2" X 7" Aluminum Hex Head Mounting Bolts. fig.3  
Order Nos. 260-284 Hose Stand w/Start & Stop Buottons  
260-HS Hose Stand Only

**Control Panel w/ Timer and 24 Volt Stop/Start (Optional):** The Control Panel includes a 120/240 volt to 24 volt Transformer and a Timer to automatically shut off the pump after a selected time. The Red Stop Switch and the Green Start Switch installed in the Hose Stand operate on 24 volt for safety. Upon request they can be mounted in a separate nema-4 electrical box. fig.4  
Order No. 161-A-2000

**Hazardous Location Rated Motors and Switches (Optional):** Check With Factory fig.5

**Hydrant (Optional):** 1 1/2" Bronze Check Valve, Bronze Ball Valve and Quick Clamp Hose Adapter with Bronze Elbow and Close Nipple with Bronze Mounting Flange. fig.6  
Order No. 270BR-150

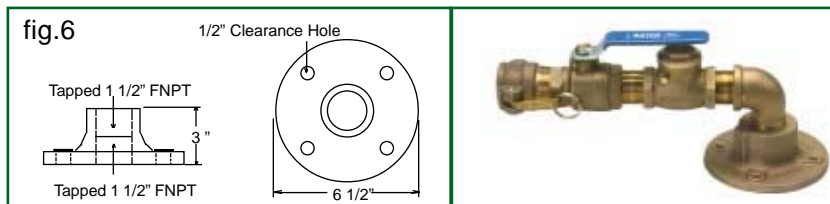
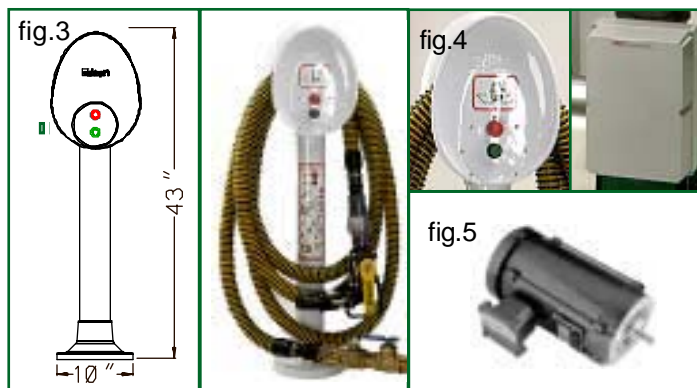

#### For Portable Applications

**Waste Hose Assembly 2" (Optional):** This kit includes all the hose, fitting and adapters needed to install an Edson Diaphragm Pump to any size collection tank. fig.7 and pg.4 Installation Waste Hose Installation Drawing.  
Order No. 279WHA-200

**12Volt Electrical Motor (Optional):** For boat and truck mounted portable pump outs using a 3/4 HP 12 volt motor to power the pump is a very efficient use of energy and the quite on demand operation is preferred over gasoline power engine. The electric power comes from a battery recharged by the engine driven altinator while moving from pump out to pump out.  
Order No. 161-A-1432



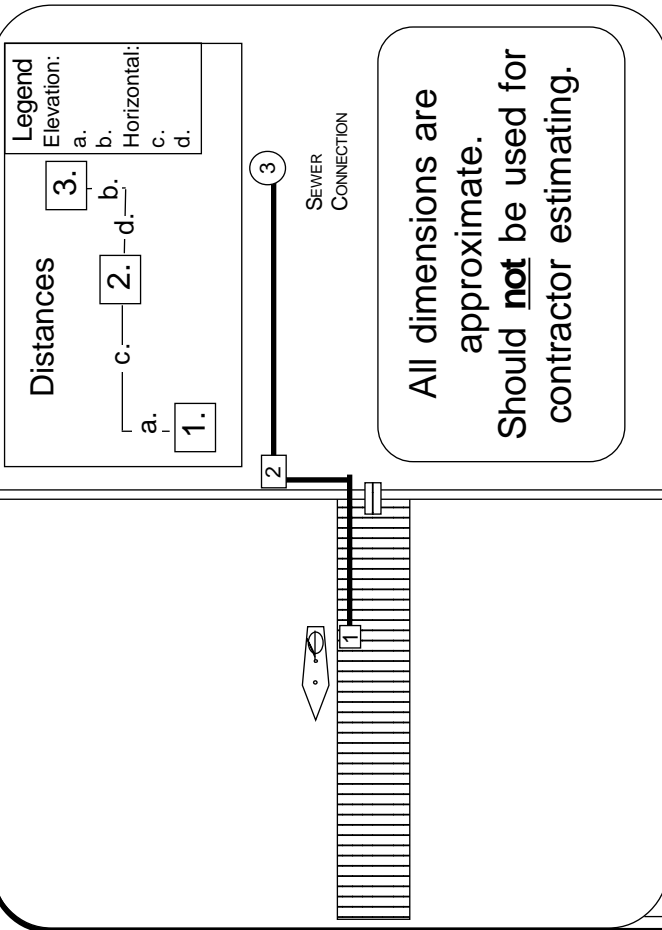

2. Bronze Pump

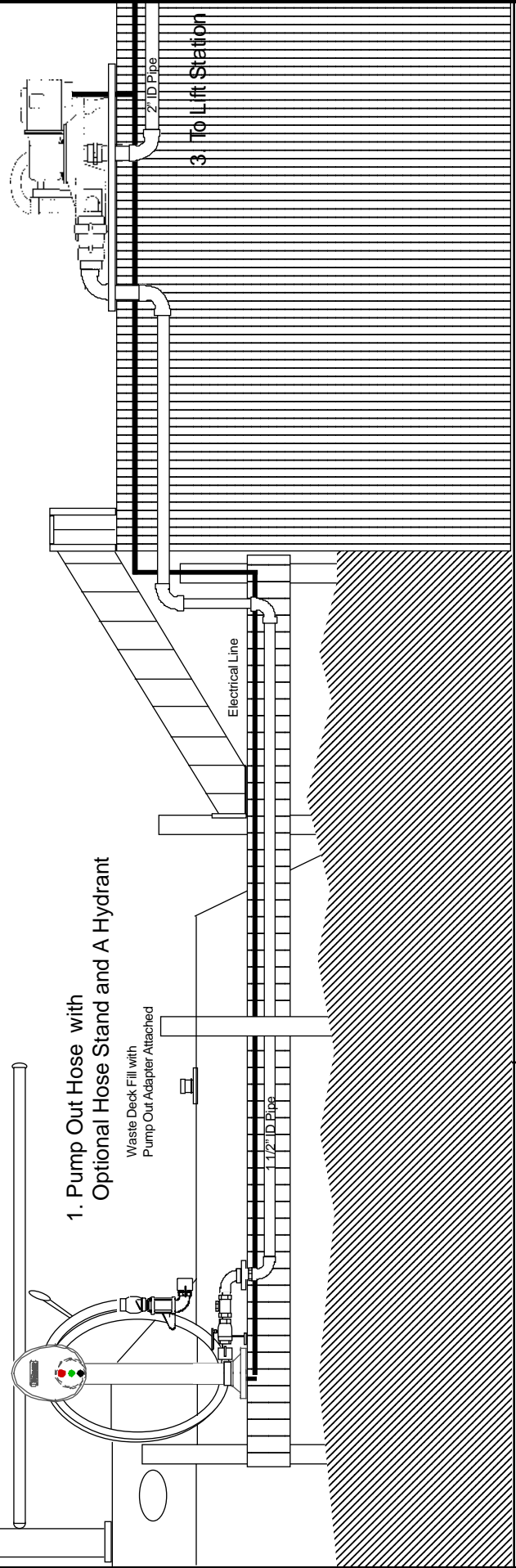

146 Duchaine Blvd.  
New Bedford, MA 02745  
Tel:508-995-9711 Fax:508-995-5021

**278EB-40 Pump Out W/ Options**

## Tank Set UP

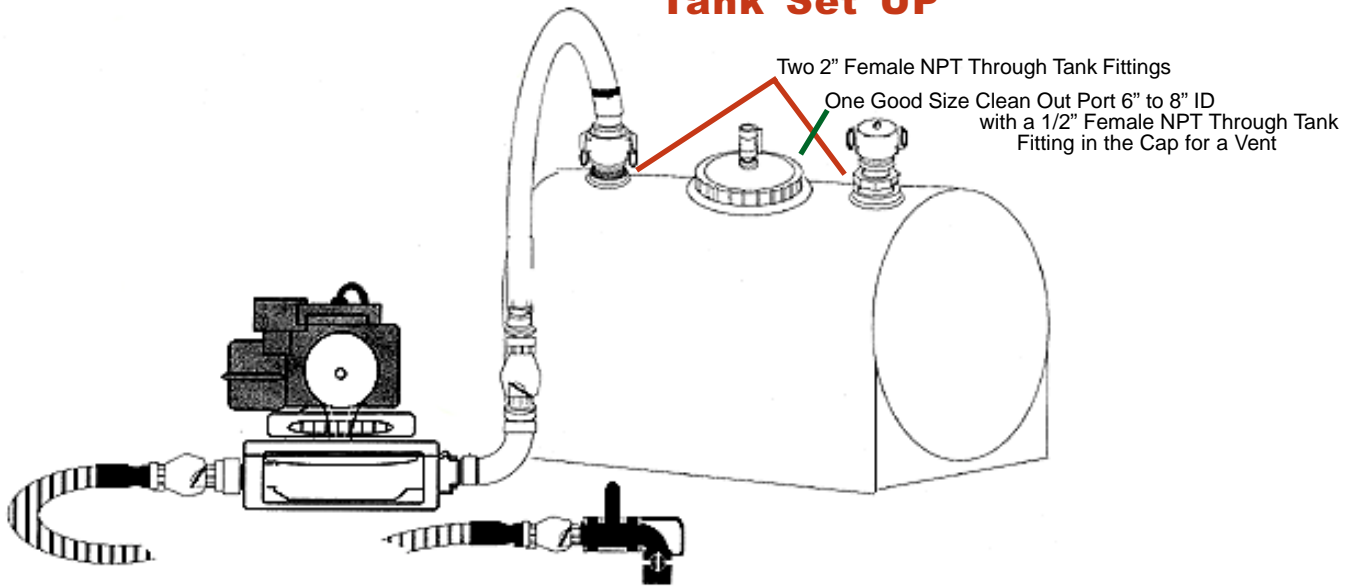

## Kit Installation

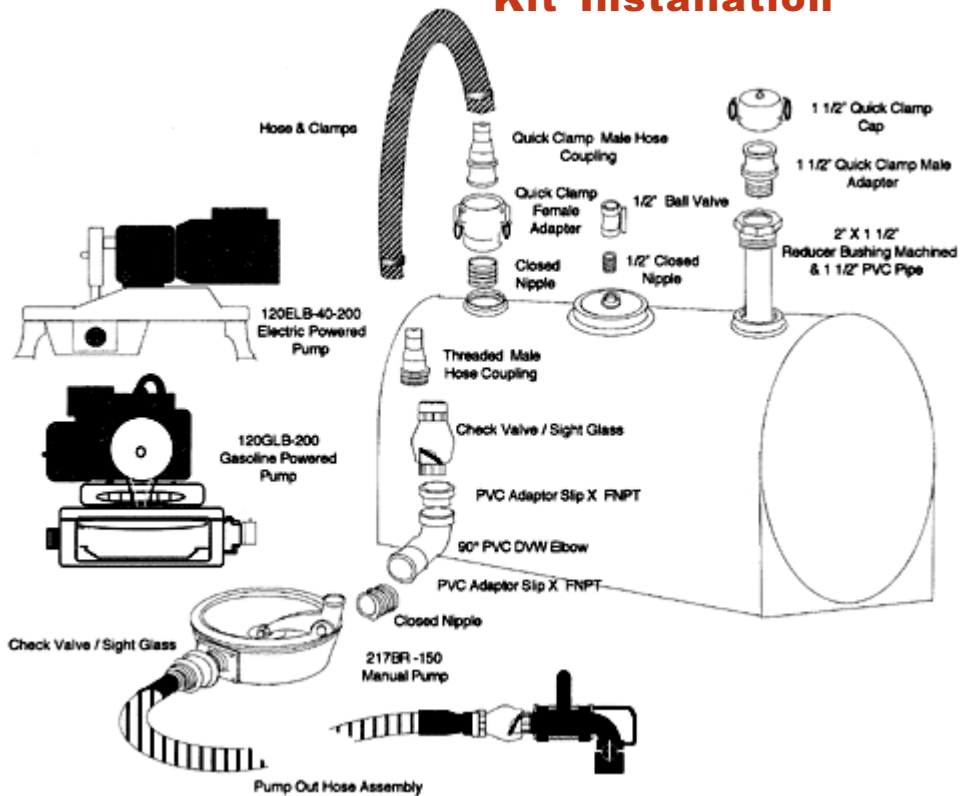



## Self Contained Liquid Waste Collection Unit

- PORTABLE SKID MOUNT WITH OPTIONAL TRAILER
- PUMP OUT RATES TO 40 GPM
- EASY FILL & OFF LOAD OPERATION
- DRY START LIFT TO 25'
- PUMP UP TO 50% SOLIDS
- RUGGED, DEPENDABLE, OIL PROTECTED VACUUM PUMPS
- QUIET RUNNING ELECTRIC OR GASOLINE ENGINE MODELS
- OPTIONAL PUMP OUT HOSE & FITTINGS
- EASY TO USE LOW MAINTENANCE OPERATION

Edson's Portable Vacuum Pumping System 290 235 03 is a convenient, easy to use waste collection system that is totally self contained on a steel skid. There is an optional over the road trailer available on which the skid can be mounted. This vacuum system is ideal for marinas that can not connect a pump out directly to a shore side sewer system but need to collect and transport the waste. The portable vacuum unit comes complete with a 235 gallon collection tank a #03 vacuum pump powered with 1 hp electric motor a 2.5 HP gas engine. It is equipped with a simple air valve system for switching from vacuum for filling the collection tank to pressure for emptying the collection tank.

An optional pump out hose assemblies come complete with all fittings and adapters necessary to pump out any boat.



**290-235-03**

Shown With Optional Gas Engine

## Edson Vacuum Pump Out Systems

**VACUUM PUMP:** #03 Oil Protected Rotary Vane 20 CFM ● Max. Volume - 40GPM / 152 LPM ● Suction Lift - to 25 ft / 7.6m ● Discharge Head - to 23 ft / 7m ● Powered By Electric Motor - 1 HP, Single Phase, 110/220 Volt, 60 HZ, TEFC ● Powered By Optional Gasoline Engine - 2.5 HP.

**TANK & SKID ASSEMBLY:** 235 Gal. Steel Tank Mounted on a Steel Skid with Lifting Eyes & Cover ● 12" Manway ● Internal Primary Shut-Off ● Oil Filled Vacuum/Pressure Gage ● Moisture Trap ● Pressure Relief Regulators ● Two 2" Sight Glass ● 2" Ball Valves w/ Male Cam Locks On Inlet and Discharge ● 20 ft. of 2" High-Vac Hose w/ Female Cam Locks Both Ends ● Stainless 4 Way Manual Slide Valve

**OPTIONAL TRAILER:** Built to Accept Skidded Unit ● 3000 LB Capacity Axle ● Fenders ● Motor Splash Guard ● Optional Electric Brakes ● Optional Tail Light Kit

**OPTIONAL PUMP OUT HOSE ASSEMBLY:** 1 1/2" Polyflex Hose ● 90° Ball Valve ● Sight Glass/Check Valve ● Quick Clamp Adapter ● Complete Set of Deck Adapters ● 25 ft Length Standard ● 50ft Optional

### ORDERING INFORMATION

DESCRIPTION <i>See Price List For Other Models</i>	WEIGHT (Lbs / Kgs)	ORDER NO.
Electric Powered Portable Vacuum System, 235 Gal., 1HP	700 / 313.6	290-235-03E1G
Gasoline Powered Portable Vacuum System, 235 Gal., 2.5HP	700 / 313.6	290-235-03G2.5G
Trailer	250 / 112	230 - 23503
25 ft Pump Out Hose Assembly	25 / 11.2	261-25-150
50 ft Pump Out Hose Assembly	35 / 15.7	261-50-150

**Edson**  
**INTERNATIONAL**

146 Duchaine Blvd., New Bedford, MA 02745-1292 Tel. 508-995-9711 Fax 508-995-5021

E-Mail pumps@edsonintl.com

www.edsonpumps.com

**Electric Powered Portable Vacuum System,  
235 Gal., 1HP fig.1**

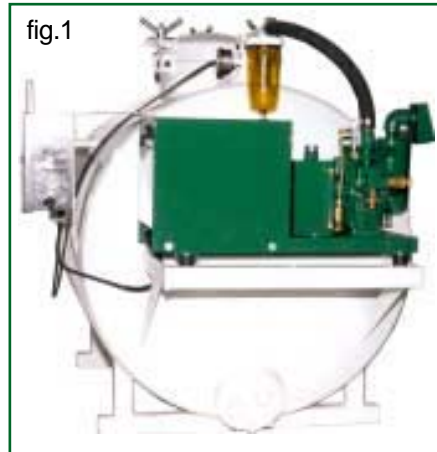

**Optional Hose Assembly:** 25' or 50' X 1 1/2" ID Polyflex Hose, 90° Ball Valve, Sight Glass/Check Valve, Quick Clamp Adapter, Complete Set of Deck Adapters.fig.2

**Optional Trailer:** Built to Accept Skidded Unit, 3000 LB Capacity Axle, Fenders, Motor Splash Guard, Optional Electric Brakes, Optional Tail Light Kit. fig.3

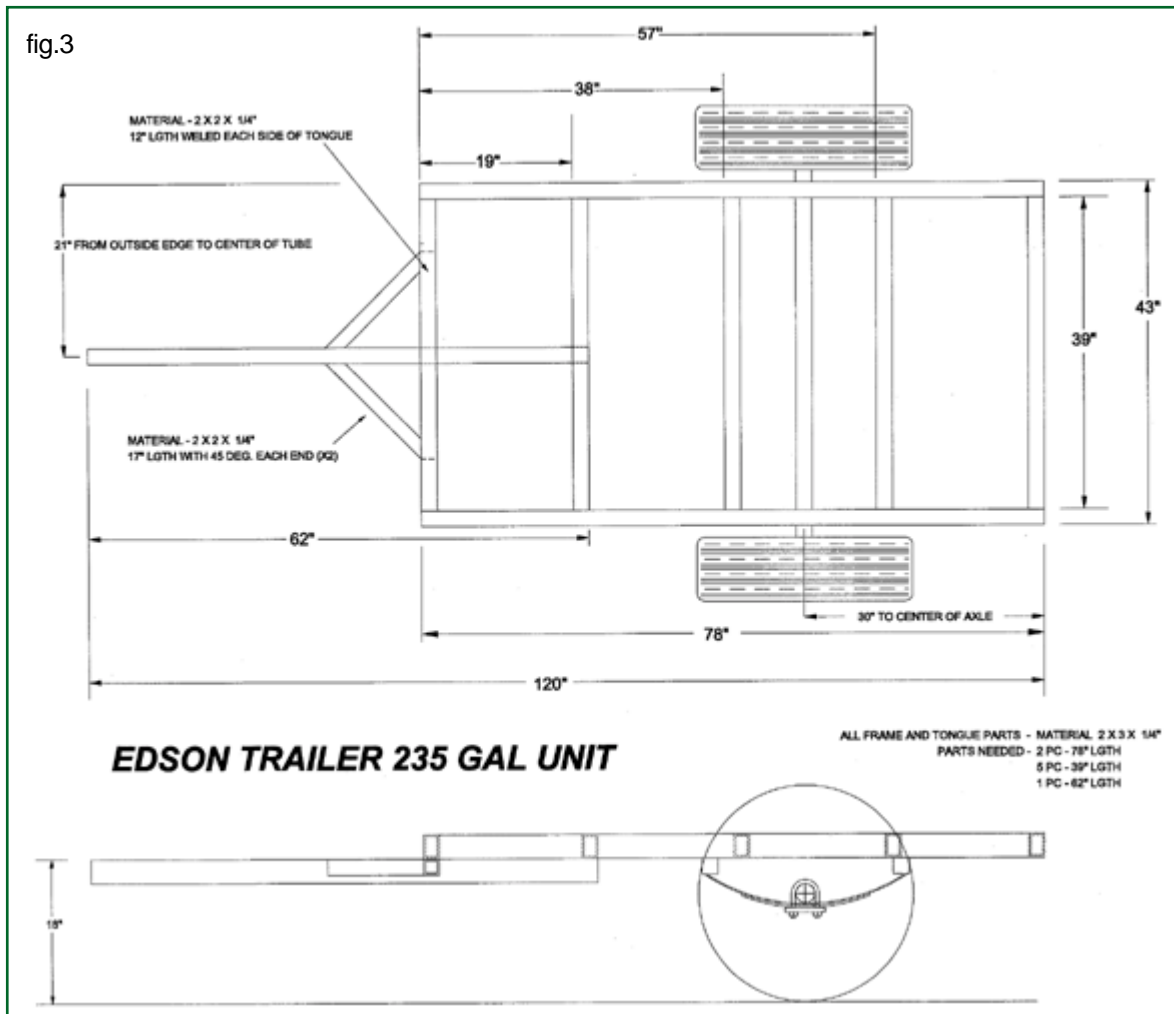

Pump Division

**Edson**  
 INTERNATIONAL

146 Duchaine Blvd., New Bedford, MA 02745-1292 Tel (508) 995-9711 Fax (508) 995-5021 E-Mail: pumps@edsonintl.com

# 286EP SERIES PERISTALTIC PUMP

## Features:

- Up to 40GPM
- Handles up to 60% suspended solids
- Self Priming to 27ft
- 65ft Discharge Head
- 27ft Suction Lift
- Easy Maintenance

## Applications:

- Waste Slurry Transfers
- Grease Interceptors
- Oil, Water, Coolant Sump Draining
- Marine / Recreational Pump-Outs
- Pit Dewatering
- Your Application ?



286EP Pump



286EP-40



282EP-60



## General Construction:

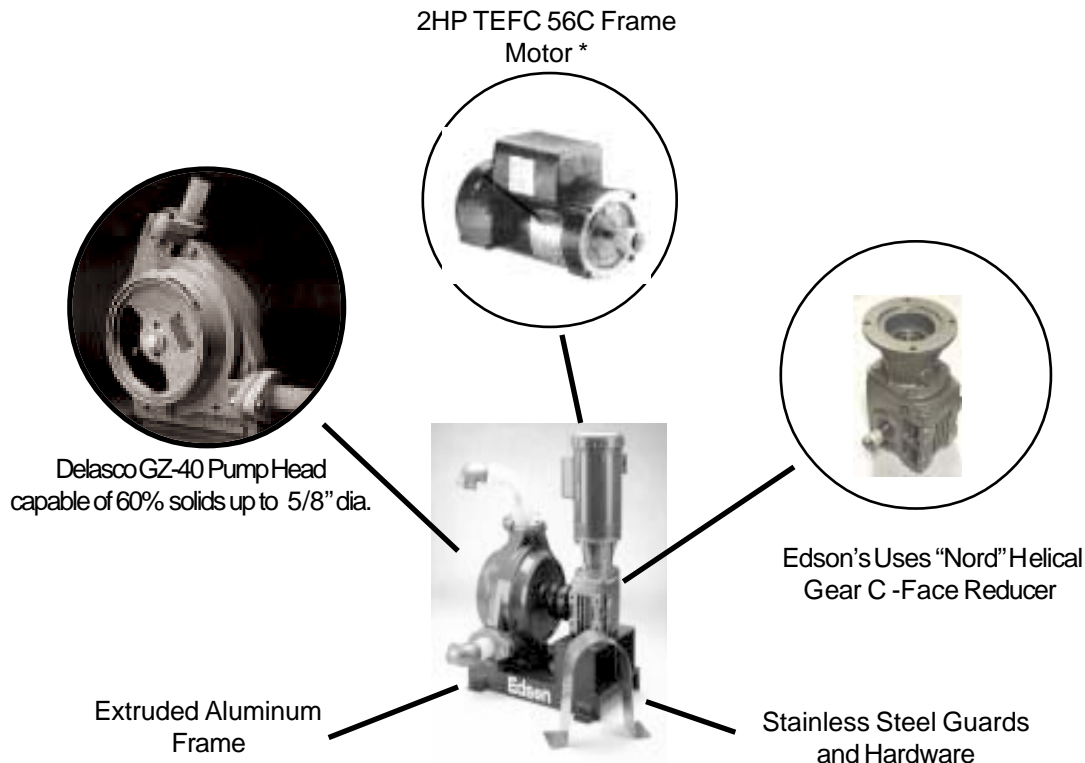

## How It Works:

As the pump rotates, the series of rollers compress the hose. The rollers travel along the hose moving the solution ahead to the discharge outlet. The hose expanding behind the roller creates a vacuum drawing more solution into the pump. Creating up to 27ft of dry suction lift.

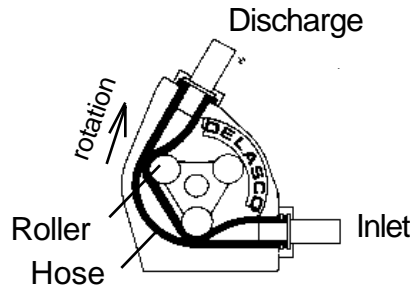

## Advantages:

The advantages of this design are high suction and discharge heads for solid laden slurries with no valves to clog, no solution contacting moving parts, run dry capability, and no seals to leak.

**Up to 65ft discharge head and 27ft dry suction lift**

## Motor Options:

- 2 HP @3450rpm
- 1 hp @1750rpm
- 120/220V 1ph
- 120/220V 1ph
- 240/480V 3ph
- 240/480V 3ph
- 12V DC
- 12V DC

\*\*Other motor options are available including special electrical requirements and gasoline powered units.

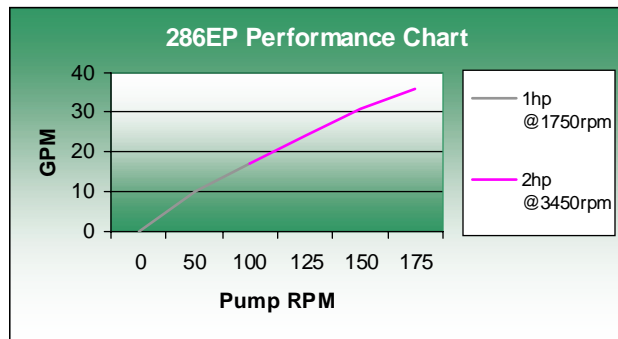

# High Performance Pumping Station 286EP-40



**286EP-40**

Shown with optional bronze hydrant

The 286EP Peristaltic Pump is ideally suited for pumping slurries such as sewage and waste waters from marinas, recreational areas and collection sumps.

## 286EP-40 Pump Out Station includes:

- 286EP Peristaltic Pump
- Fiberglass Enclosure
- White powder coated hose stand
- Timer control panel with "auto off"
- 24Volt safety start stop station
- 25' x 1 1/2" dia. hose assembly which includes:
  - 90° ball valve
  - set of (4) four deck / drain adapters
  - sightglass check valve

## Dimensional Information:

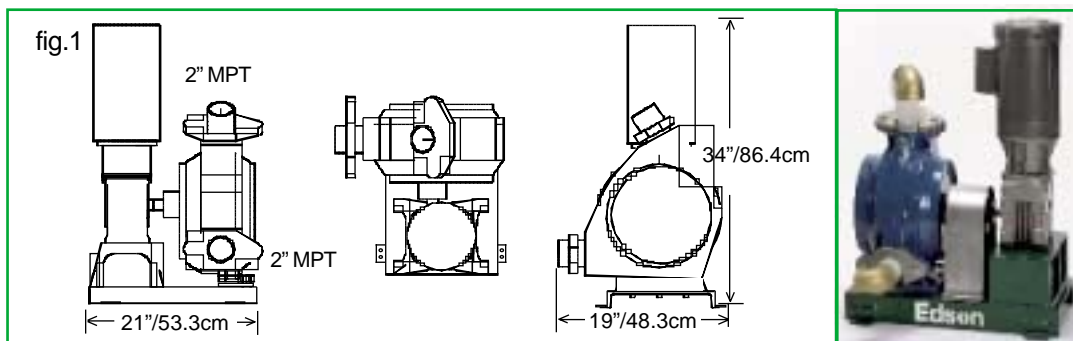

Figure 1: 286EP Peristaltic Pump

## Hose Material Options:

- Anti Abrasion
- EPDM
- Butyl
- Nitrile
- Hypalon
- Neoprene

### *Its That Easy!!*

The hose on the pump needs lubrication\* and inspection periodically depending on frequency of use.



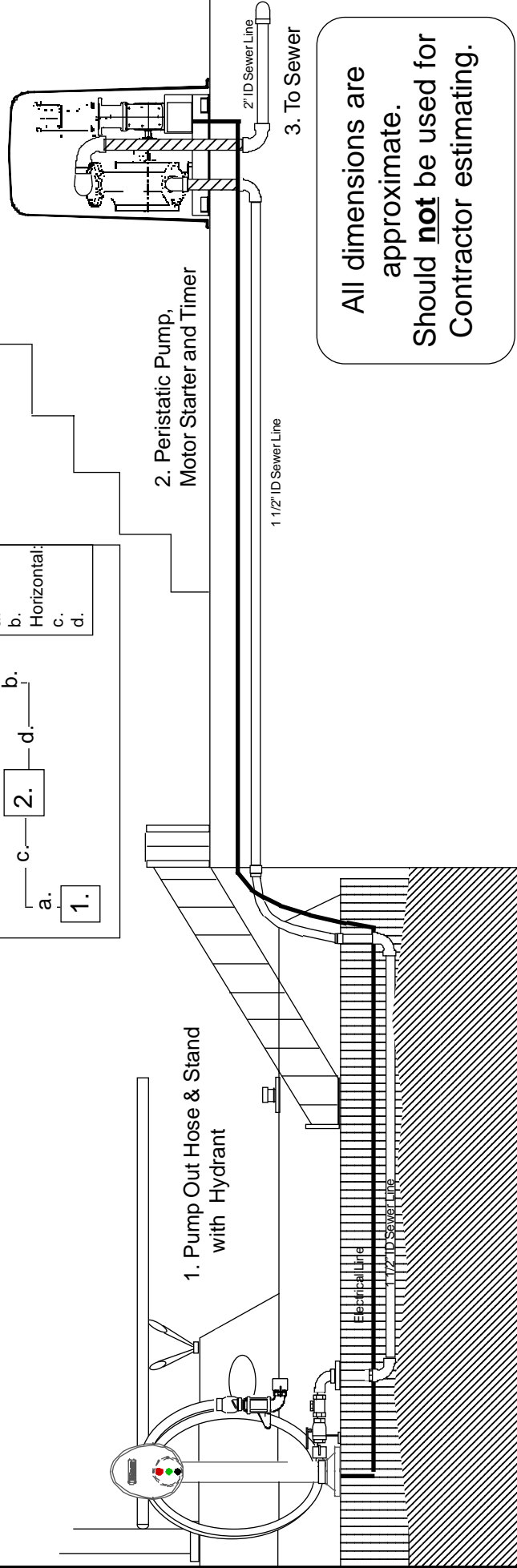
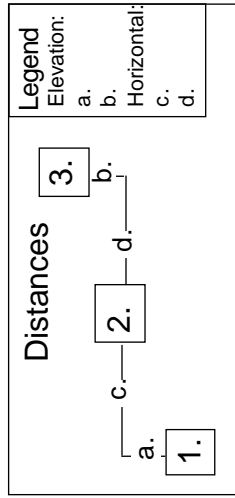
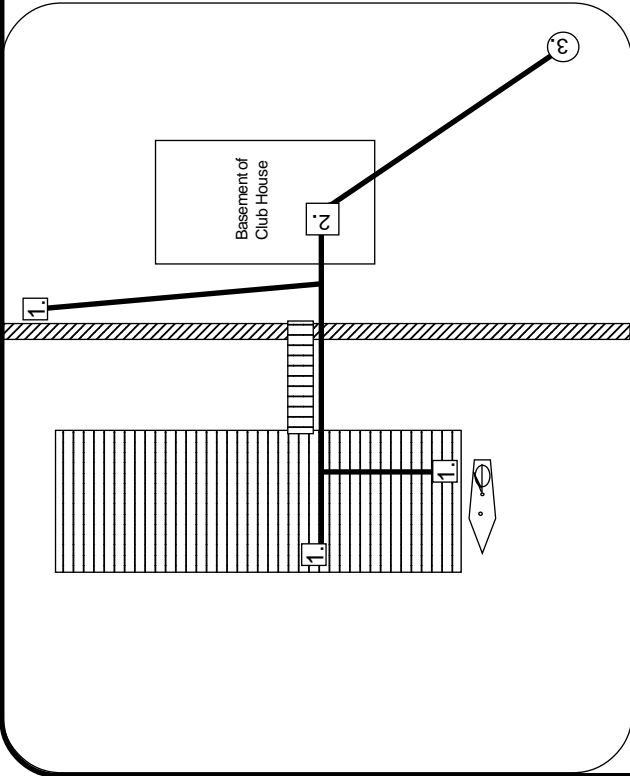

All dimensions are approximate.  
Should **not** be used for Contractor estimating.

## 286EP-40 Pump Out

APPENDIX 3: 1934 LICENSE FOR 400 BORDER STREET PROPERTY

Form WD 54.  
March-15-'33. No. 4179-2a.

# The Commonwealth of Massachusetts

No. 1574.



Whereas, the Mystic Steamship Company,-----  
of Boston-----, in the County of Suffolk-----and Commonwealth  
aforesaid, has applied to the Department of Public Works for license to build and maintain  
a bulkhead and to widen and repair an existing wharf in Boston  
Harbor at East Boston in the city of Boston,-----  
and has submitted plans of the same; and whereas due notice of said application, and of the time and  
place fixed for a hearing thereon, has been given, as required by law, to the -----Mayor  
and City Council---of the city---of Boston-----;

Now, said Department, having heard all parties desiring to be heard, and having fully considered said  
application, hereby, subject to the approval of the Governor and Council, authorizes and licenses the said  
Mystic Steamship Company-----, subject to the provisions of the ninety-  
first chapter of the General Laws, and of all laws which are or may be in force applicable thereto, to  
build and maintain a bulkhead and to widen and repair an exist-  
ing wharf in Boston Harbor at East Boston in the city of Boston,  
in conformity with the accompanying plan No. 1574.

A new bulkhead of 6-inch sheeting anchored to a con-  
crete anchorage may be constructed for a length of about 66 feet  
upon a line approximately 2 feet in front of the present timber

bulkhead and parallel with the existing structure, in the location shown on said plan and in accordance with the details of construction there indicated.

The present "South Pier" shown on said plan, may be widened to 26 feet for a length of about 337 feet and the outer end may be repaired by installing new fenders and bracing, in the location shown on said plan and in accordance with the details of construction there indicated.

At the inner end of the present wharf on the northerly side, a new fillet may be built for a length of about 26 feet along the northerly side of the wharf and of about 20 feet along the line of the new bulkhead as shown on said plan.

Nothing in this license shall be construed as authorizing any work on land, flats or structures not owned by the licensee without the consent of the owner or owners of such property.-----

The plan of said work, numbered -----1 5 7 4,----- is on file in the office of said Department, and duplicate of said plan accompanies this License, and is to be referred to as a part hereof.

The amount of tide-water displaced by the work hereby authorized shall be ascertained by the Department, and compensation therefor shall be made by the said ----- Mystic Steamship Company, its-----heirs, succes

and assigns, by paying into the treasury of the Commonwealth thirty-seven and one half-  
(37½) ----- cents for each cubic yard so displaced, being the amount hereby assessed  
by said Department.

Nothing in this License shall be so construed as to impair the legal rights of any person.

This License shall be void unless the same and the accompanying plan are recorded within  
one year from the date hereof, in the Registry of Deeds for the -----  
District of the County of Suffolk.

In Witness Whereof, said Department of Public Works have hereunto set their hands this  
third----- day of April,----- in the  
year nineteen hundred and thirty-four.

..... F E Lyman .....	} Department of Public Works
..... Richard K Hale .....	
..... Wm F. Callahan .....	

THE COMMONWEALTH OF MASSACHUSETTS

~~This license is approved in consideration of the payment into the treasury of the Commonwealth by the  
said  
of the further sum of  
the amount determined by the Governor and Council as a just and equitable charge for rights and privileges  
hereby granted in land of the Commonwealth.~~

BOSTON, Apr. 4, 1934

Approved by the Governor and Council.

..... William L. Reed .....

Executive Secretary.

A true copy.

Attest: *May A Sily* .....

Secretary.

