



Missouri University of Science and Technology
Scholars' Mine

International Specialty Conference on Cold-Formed Steel Structures

Wei-Wen Yu International Specialty Conference on Cold-Formed Steel Structures 2018

Nov 7th, 12:00 AM - Nov 8th, 12:00 AM

SDI Steel Deck on Cold-Formed Steel Framing Design Manual

Thomas Sputo

Follow this and additional works at: <https://scholarsmine.mst.edu/isccss>

 Part of the [Structural Engineering Commons](#)

Recommended Citation

Sputo, Thomas, "SDI Steel Deck on Cold-Formed Steel Framing Design Manual" (2018). *International Specialty Conference on Cold-Formed Steel Structures*. 1.
<https://scholarsmine.mst.edu/isccss/24iccfss/session6/1>

This Article - Conference proceedings is brought to you for free and open access by Scholars' Mine. It has been accepted for inclusion in International Specialty Conference on Cold-Formed Steel Structures by an authorized administrator of Scholars' Mine. This work is protected by U. S. Copyright Law. Unauthorized use including reproduction for redistribution requires the permission of the copyright holder. For more information, please contact scholarsmine@mst.edu.

Wei-Wen Yu International Specialty Conference on Cold-Formed Steel Structures
St. Louis, Missouri, U.S.A., November 7 & 8, 2018

SDI Steel Deck on Cold-Formed Steel Framing Design Manual

Thomas Sputo, Ph.D., P.E., S.E.¹

Introduction

The First Edition of the *SDI Steel Deck on Cold-Formed Steel Framing Design Manual* is the first design manual that specifically addresses the design of steel deck on cold-formed framing. The design of the steel deck is similar to deck on heavier rolled beams or open web steel joists, but it requires attention to some different detailing and fastening methods. This Manual concentrates on these differences.

The Manual Section contains an introduction to the topic, and sections specific to roof deck, floor deck, and fasteners. The roof and floor deck sections include diaphragm applications. The Manual contains tables for fasteners and diaphragms, and also includes 7 design examples specific to deck on cold-formed framing.

The Manual makes use of an on-line design tool, the *SDI Diaphragm Interaction Calculator*, which develops diaphragm tables for the situation where the diaphragm capacity is reduced by wind uplift.

This Manual conforms to the ANSI/SDI RD-2017 *Standard for Steel Roof Deck*, the ANSI/SDI NC-2017 *Standard for Non-Composite Steel Floor Deck*, ANSI/SDI C-2017 *Standard for Composite Steel Floor Deck-Slabs*, the AISI S100-16 *North American Specification for the Design of Cold-Formed Steel Structural Members* and the AISI S310-13 and -16 editions of the *North American Standard for the Design of Profiled Steel Diaphragm Panels*.

¹ Technical Director, Steel Deck Institute; and Consulting Structural Engineer, Sputo and Lammert Engineering, LLC (tsputo50@gmail.com).

Manual Format and Coverage

The SDI *Steel Deck on Cold-Formed Steel Framing Design Manual* is divided into a Forward and eight sections as follows:

Section 1	Introduction
Section 2	Roof Deck
Section 3	Floor Deck
Section 4	Fasteners
Section 5	Examples
Section 6	Fastener Tables
Section 7	Diaphragm Tables
Section 8	References

This new Manual provides information on how the use of steel floor and roof deck on cold-formed steel framing differ from when supported on open web steel joists or rolled beams.

1. The Manual complies with the analysis and design methods contained within the AISI S100 and S310 Standards, taking into account the more flexible behavior of screw fasteners in cold-formed supports.
2. The Manual contains seven design examples illustrating the design and analysis of steel deck on cold-formed steel framing, both roof and floor deck, and diaphragms.
3. Examples also show the calculation of diaphragm strength and stiffness using the AISI S310 provisions when supported by cold-formed steel framing.
4. Examples include expanded discussion of the interaction of wind uplift with diaphragm strength.
5. Fasteners included in the Manual include generic screws in accordance with the strength and flexibility provisions of AISI S100 and S310
6. Diaphragm load tables are calculated using the generic AISI S310 weld and screw provisions, and calculated using the previous 3rd Edition DDM fastener equations and proprietary fasteners. The same resistance and safety factors apply to both methods.

Section 1 - Introduction

Section 1 introduces the general differences when designing deck to be supported on cold-formed framing. The Manual supposes that the user is already conversant with designing deck on open web steel joists and rolled beams.

First, the user is introduced to the thinner supporting material, as shown in Table 1. Not all base steel thicknesses are available from all suppliers, and 27 mil material is rarely used for floor and roof joists, while 118 mil material is rarely used in trusses.

Thickness Designation (mils)	Minimum Thickness (inches)	Design Thickness (inches)	Reference Gage (Not Used for Specifying)
27	0.0269	0.0283	22
33	0.0329	0.0346	20
43	0.0428	0.0451	18
54	0.0538	0.0566	16
68	0.0677	0.0713	14
97	0.0966	0.1017	12
118	0.1180	0.1242	10

Table 1. Structural Cold-Formed Framing Base Steel Thickness

Floor and roof framing can be constructed either of trusses or of individual members. The design of the framing is beyond the scope of this manual, and the user is referred to any of several publications that are listed in the General References section of this Manual. However, it is important that the designer be cognizant of the limitations that the shape of the supporting framing imposes on the design of the steel deck.

Individual members used as floor joists or roof rafters are usually lipped channels, as shown in Figure 1. There are industry standard cross sections that are available from many manufacturers.



Figure 1. Lipped Channel

The flange width is important to consider when designing the bearing and attachment of the steel deck to the flange. Typical standard flange widths for structural cross sections are 1-5/8 inch (S162), 2 inch (S200) and 2-1/2 inch (S250). Also available, but not as commonly used in this application are 3 inch (S300) and 3-1/2 inch (S350).

Cold-formed steel trusses are commonly used for both floor and roof applications. Trusses are usually designed by the manufacturer as a specialty engineered item. Trusses can use lipped channels for top chords (referred to as C-Section Trusses), however there are proprietary sections used by some truss manufacturers, as shown in Figure 2.

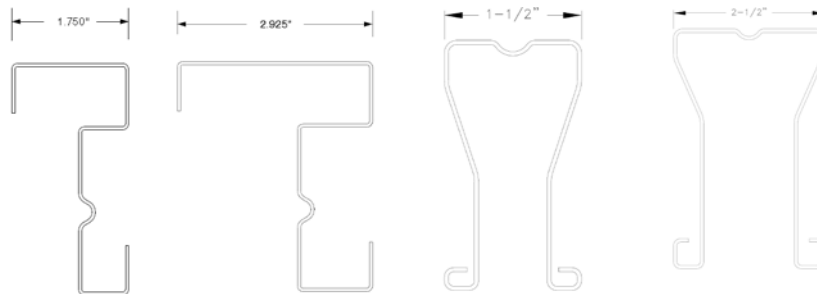

Figure 2. Proprietary Truss Chords (Courtesy of Aegis and Alpine Trussteel)

The Chapter closes out by reminding users that specific responsibilities for design are laid out in two Code of Standard Practice publications; the AISI Code of Standard Practice for Cold-Formed Steel Structural Framing (AISI S202) and the SDI Code of Standard Practice (SDI-COSP).

Section 2 - Roof Deck

Any of the roof deck profiles shown in the SDI Roof Deck Design Manual (RDDM) can be used on cold-formed steel roof trusses or rafters, with 1-1/2 inch Wide Rib (WR) deck (Figure 2.1) being the most common for spans of up to 8 feet. Engineering information, including section properties and span tables, can be found in the RDDM and in manufacturers literature.

This section provides an extensive development of sloped roof diaphragms, including monoslope, gable, and hipped roofs, as shown in Figures 3 and 4.

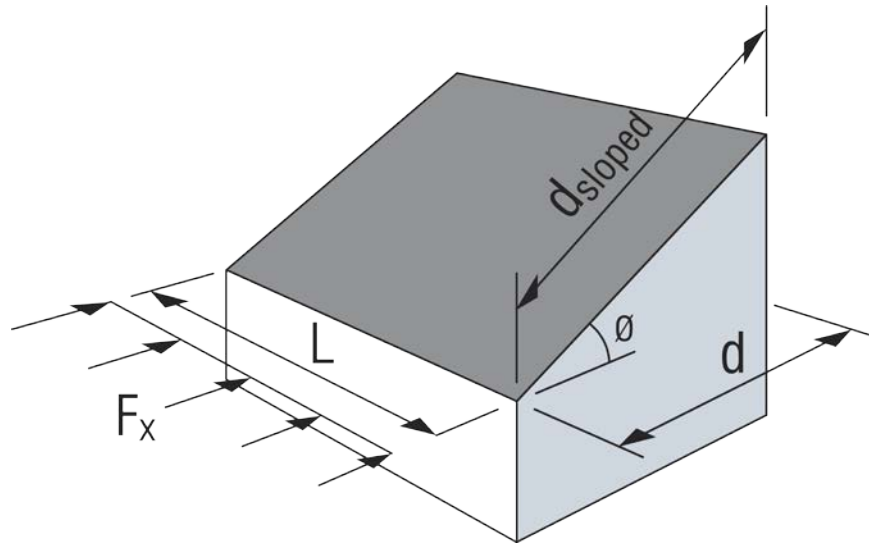

Figure 3. Monoslope Diaphragm, Laterally Loaded

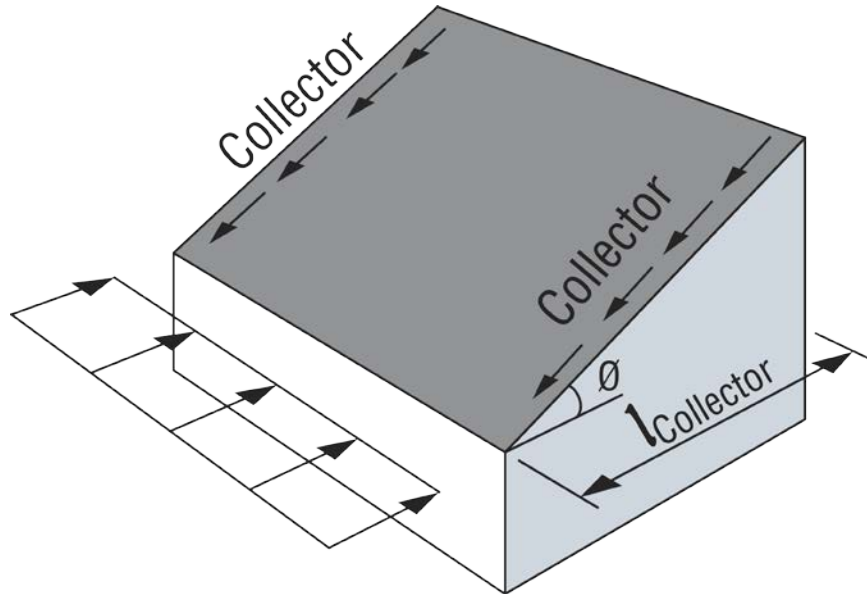

Figure 4. Monoslope Diaphragm Transverse Collectors

Roof diaphragms that are loaded by wind must resist both in plane shear and uplift. There are two loading conditions that must be considered:

- A. The roof deck is designed as the sheathing for the roof. For this case, the wind uplift on the deck and fasteners is calculated using component and cladding (C&C) wind pressures.
- B. The roof deck is designed as a diaphragm. For this case, the wind uplift and in plane diaphragm shear are both calculated using main wind force resisting system (MWFRS) wind pressures.

The application of combined wind uplift and diaphragm shear is covered in the manual, along with the accompanying "Diaphragm Interaction Calculator."

Section 3 - Floor Deck

Any of the floor deck profiles shown in the SDI Floor Deck Design Manual (FDDM) can be used on cold-formed steel floor trusses or joists. Engineering information, including section properties and span tables, can be found in the RDDM and in manufacturers literature. For closely spaced trusses or joists (48

inches or less on center), form deck of 9/16 inch to 1 inch in depth can also be used. For longer spans, deeper form deck or composite deck can be used.

Form deck is most often galvanized, and if galvanized, it is permitted to be considered to be a permanent form that supports the weight of the concrete slab, with the concrete slab designed to support the weight of the superimposed loads. Alternately, it is allowed to use bare or painted deck as permitted by the applicable SDI Specification (SDI C or SDI NC).

There are some design considerations that are common to both composite and non-composite (form) deck used for floors. Refer to Figure 5.

A. Available flat bearing width of the framing top flange may not permit the use of butted deck ends once the required deck bearing length (minimum of 3/4 inch per AISI S100) is taken into account. Also, minimum fastener end distance in the deck (1.5 times the screw diameter per AISI S100) may not be able to be met (for instance, minimum end distance for a #12 framing screw would be 0.324 inches or more than 5/16 inch). Deck panel underlength within SDI Standards tolerance of 1/2 inch per deck sheet and tolerance for framing placement and straightness needs to also be factored into this consideration.

B. Minimum fastener spacing (3 times the screw diameter per AISI S100) may control the number of fasteners per deck rib. For instance, the minimum center to center spacing for a #12 support screw is 0.648 or over 5/8 inches. This, combined with end distance limits, will most likely limit the number of screws to two per deck rib for the most common framing flange widths.

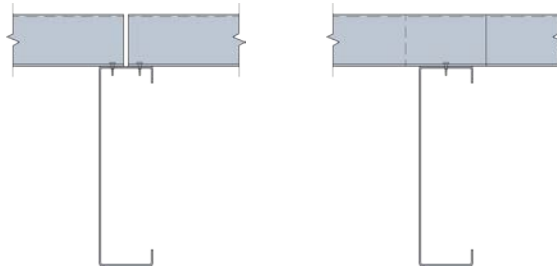

Figure 5 Butted and Lapped Deck Ends

Section 4 - Fasteners

Fasteners for attachment of steel deck to cold-formed steel framing are limited to screws, as shown in Figures 6 and 7. The application of screws in this use is similar to when attaching to heavier supporting steel, except that the additional limit states of tilting in shear, and pullout in tension, which do not normally control in heavier supporting steel, may govern design.

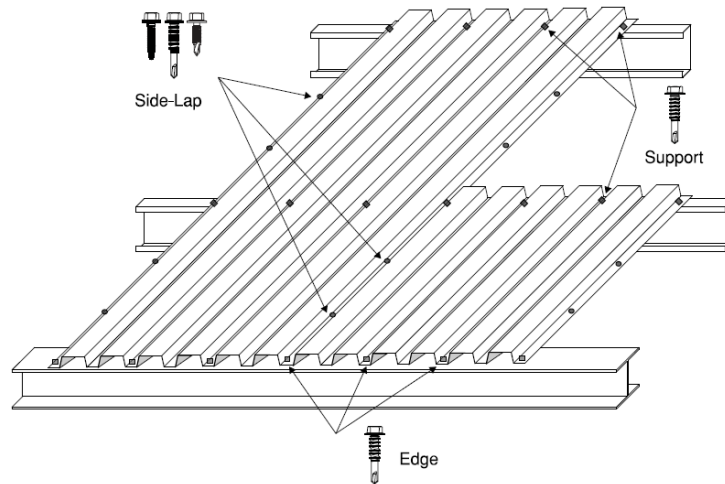

Figure 6. Support, Side-lap, and Edge Screws

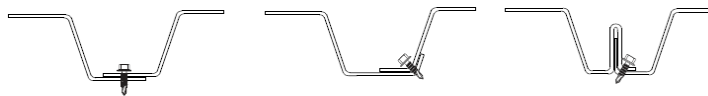

Figure 7 Nested and Interlocking Side-lap Screw Connections

Welded connections for either support attachment is **NOT RECOMMENDED** due to the difficulty in making acceptable welds between two or more layers of sheet steel. Burn-through damage to truss chords and rafter and joists flanges

often results and repairs to the supporting framing may not be possible. Any welding related damage to the support framing is not the responsibility of the framing supplier, deck supplier, or deck installer.

Welded side-laps are possible, but limitations on welding imposed by roof slope, burn through, and the cost effectiveness of screwed side-laps make welded side-laps undesirable.

Power-actuated fasteners are commonly used for steel roof deck attachment to support framing of 1/8 inch and thicker. At the time of publication of this Manual, no power actuated fasteners were available for connecting steel deck to cold-formed steel support framing. For additional information on these fasteners, refer to the SDI Roof Deck Design Manual and the literature of the product manufacturers.

As an alternative to screws, side-lap connections can be formed by crimping the upstanding edge of the deck, where provided. Crimps can only be made with deck that is designed with the upstanding edge to receive them and not all deck has upstanding edges that will accept crimps. Crimping can be categorized as either generic "button punching" or one of several proprietary mechanically formed connection systems.

Generic button punches serve only to align the deck side-laps but provide little resistance to shear at the panel edge. Proprietary mechanically formed connection systems are tested connections formed using specific tools for a specific deck. These proprietary systems have defined shear strength and stiffness values that are contained within research and acceptance reports. Information on these proprietary systems can be obtained from specific manufacturers.

Strict consideration also needs to be paid to the number of screws that are used at a single rib at a support. Minimum spacing per AISI S100 is 3 times the screw diameter, or approximately 5/8" for a No. 12 screw. That practically limits the number of screws per rib to 2 in most practical cases. At deck ends or butt joints, the minimum end distance is 1.5 times the screw diameter, which also limits the number of screws to 2 in a rib.

Section 5 - Examples

Section 5 consists of seven design examples which illustrate the differences between installing steel deck on cold-formed steel framing versus heavier steel supporting framing.

Example 1	Available Diaphragm Shear Strength in the Absence of Uplift Where the Support is Cold-Formed Steel Framing
Example 2	Stiffness of the Configuration in Example 1
Example 3	Available Diaphragm Shear Strength With Wind Uplift Where the Support is Cold-Formed Steel Framing
Example 4	Roof Deck (ASD)
Example 5	Floor Deck (ASD)
Example 6	Gable Roof with Open Ridge
Example 7	Loads on Diaphragm - Gable Roof Loaded on Endwall

Example 3 is a rigorous development of the interaction of shear and uplift in a wind loaded roof. This example will prove useful to designers in understanding the interaction that develops in fasteners.

Section 6 - Fastener and Framing Tables

Section 6 contains tables which will assist the user in designing fasteners

Table 1	Screw Dimensional and Tensile Strength
Table 2	Screw Nominal Pull-out Strength
Table 3	Screw Nominal Pull-over Strength
Table 4	Sidelap Screw Nominal Shear Strength
Table 5	Support Screw Nominal Shear Strength
Table 6	Support Screw Flexibility
Table 7	Sidelap Screw Flexibility
Table 8	Roof Deck Fastener Patterns
Table 9	Spanning Zee Framing











Attachment Patterns	C	Screws k
36/9 	3	7
36/7 	3	6
36/5 	3	4
36/4 	3	3
35/8 	2.92	7
35/7 	2.92	6
35/6 	2.92	5
35/5 	2.92	4
30/7 	2.5	6
30/5 	2.5	4
30/4 	2.5	3

Figure 8 - Roof and Form Deck Fastener Patterns

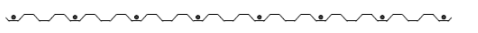
Section 7 - Diaphragm Tables

Section 7 includes tables for both filled and bare deck diaphragms.

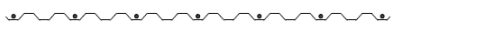
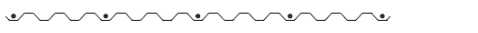
For concrete filled floor diaphragms, a simplified table which considers only the contribution of the fill above the top of the deck ribs is included, and is shown as Figure 9.

Nominal Diaphragm Shear Strength, S_n , PLF
ASD ($\Omega = 3.25$) LRFD ($\Phi=0.50$)

Concrete Thickness Above Deck (inches)	Normalweight Concrete (145 pcf)		Lightweight Concrete (115 pcf)	
	3000 psi	4000 psi	3000 psi	4000 psi
1.5	2943	3398	2078	2400
2	3923	4530	2771	3200
2.5	4904	5663	3464	4000
3	5885	6796	4157	4800
3.5	6866	7928	4850	5600

Notes:

1. This table considers only the contribution of the concrete to the diaphragm resistance.
2. Per SDI-NC, the minimum thickness of a structural concrete slab is 1-1/2 inches above the top of the non-composite steel deck.
3. Per SDI-C, the minimum thickness of a composite concrete slab is 2 inches above the top of the composite steel deck.

Figure 9 - Concrete Filled Diaphragm Table

For bare deck roof diaphragms, tables which are similar to those in DDM04 are provided for deck on cold-formed supporting framing. Each different combination of deck thickness, support framing thickness, and support framing ultimate strength is included. The tilting behavior of the support fastener screws in different thickness of support framing creates many more tables than are

found in DDM04, where fastener tilting is not a design limit state. An example of a typical table is shown in Figure 10.

1.5WR22
Design thickness = 0.0295 in.
F _{y-deck} = 33 ksi
F _{u-deck} = 45 ksi
Framing designation = 33 mils
Framing thickness = 0.0346 in.
F _{y-framing} = 33 ksi
F _{u-framing} = 45 ksi
Support fastening: #12 screws
Side-lap fastening: #10 screws

Loading	S310-13		S310-16	
	φ _{tr}	Ω _{tr}	φ _{tr}	Ω _{tr}
Seismic	0.65	2.50	0.70	2.30
Wind	0.70	2.35	0.80	2.00
Other	0.65	2.50	0.70	2.30

Fastener Layout	Side-lap Conn/Span	Nominal Shear Strength, S _{tr} , plf ²						K ₁ 1/ft
		Span						
		24"	32"	48"	64"	72"	96"	
36/14 α ₁ =α ₂ = 4.000 α ₀ ² = α _s ² = 1.556 N= 4.000 A= 2	0	1085	850	580				0.494
	1	1220	975	680	505	445		0.382
	2	1345	1090	770	585	515	380	0.312
	3	1450	1195	860	660	585	430	0.263
	4	1550	1290	940	730	655	485	0.228
	5	1630	1375	1020	795	715	535	0.201
	6	1705	1455	1095	860	775	590	0.179
36/7 α ₁ =α ₂ = 2.000 α ₀ ² = α _s ² = 0.778 N= 2.000 A= 1	0	540	425	290				0.989
	1	670	545	385	290	255		0.624
	2	775	645	470	365	325	240	0.455
	3	850	725	545	430	385	295	0.359
	4	910	795	615	490	445	345	0.296
	5	960	850	675	545	495	390	0.252
	6	995	900	730	600	545	430	0.219
36/5 α ₁ =α ₂ = 1.667 α ₀ ² = α _s ² = 0.722 N= 1.333 A= 1	0	460	370	265				1.186
	1	550	465	345	270	240		0.697
	2	610	535	415	330	300	230	0.493
	3	655	590	475	385	350	275	0.382
	4	685	625	520	435	400	320	0.311
	5	705	655	560	475	440	355	0.263
	6	720	680	590	515	480	390	0.228
36/4 α ₁ =α ₂ = 1.333 α ₀ ² = α _s ² = 0.556 N= 1.000 A= 1	0	350	285	200				1.483
	1	435	370	280	220	200		0.790
	2	485	430	345	280	255	195	0.538
	3	515	470	390	330	300	240	0.408
	4	530	500	430	370	340	275	0.329
	5	545	520	460	400	375	310	0.275
	6	555	530	480	430	405	340	0.237

¹ Nominal shear strength shown above may be limited by shear buckling. See Table below.

Loading	S310-13		S310-16	
	φ _{db}	Ω _{db}	φ _{db}	Ω _{db}
Buckling	0.80	2.00	0.80	2.00

Deck Profile	l in ⁴ /ft	Nominal Shear Due to Panel Buckling, S _{db} , plf ²					
		Span					
		24"	32"	48"	64"	72"	96"
WR	0.173	34328	19310	8582	4827	3814	2146

² Design Strengths:

ASD Required strength (Service Applied Load) ≤ Min {S_{tr}/Ω_{tr}, S_{db}/Ω_{db}}
 LRFD Required strength (Factored Applied Load) ≤ Min {φ_{tr}S_{tr}, φ_{db}S_{db}}

Figure 10 - Typical Roof Deck Diaphragm Table

Section 8 - References

Section 8 contains references used in the Manual, along with general recommended design references for cold-formed steel framing.

Diaphragm Interaction Calculator

To reduce the design effort involved with calculating the reduced diaphragm capacity when wind uplift must be considered in the design, the SDI has provided an on-line tool to assist designers. This "Diaphragm Interaction Calculator" will calculate the ASD and LRFD diaphragm capacity for an input uplift pressure, given deck profile, material strengths, and fastener pattern and type. This calculator will provide answers for deck on both cold-formed framing, and open web steel joists and rolled steel beams.

Conclusion

The new SDI *Steel Deck on Cold-Formed Steel Framing Design Manual* represents a step forward for designers of buildings that incorporate steel deck on cold-formed steel framing.

References

American Iron and Steel Institute (2013). *ANSI/AISI S310-13 North American Standard for the Design of Profiled Steel Diaphragm Panels*, Washington, DC

American Iron and Steel Institute (2016). *ANSI/AISI S310-16 North American Standard for the Design of Profiled Steel Diaphragm Panels*, Washington, DC

American Iron and Steel Institute (2016). *ANSI/AISI S100-16 North American Standard for the Design of Cold-Formed Steel Structural Members*, Washington, DC

Steel Deck Institute (SDI) (2015). *Diaphragm Design Manual, 4th Edition*, Glenshaw, PA.

Steel Deck Institute (SDI) (2013). *Roof Deck Design Manual, 1st Edition*, Fox River Grove, IL.

Steel Deck Institute (SDI) (2014). *Floor Deck Design Manual, 1st Edition*, Glenshaw, PA.

Steel Deck Institute (SDI) (2017) ANSI/SDI RD-2017 *Standard for Steel Roof Deck*, Glenshaw, PA.

Steel Deck Institute (SDI) (2017) ANSI/SDI NC-2017 *Standard for Non-Composite Steel Floor Deck*, Glenshaw, PA.

Steel Deck Institute (SDI) (2017) ANSI/SDI C-2017 *Standard for Composite Steel Floor Deck-Slabs*, Glenshaw, PA.

Steel Deck Institute (SDI) (2018) SDI *Steel Deck on Cold-Formed Steel Framing Design Manual*, Glenshaw, PA.