

EXPERIMENTAL AND NUMERICAL INVESTIGATION ON HYDRO-FORMING OF STEPPED TUBES FOR ALUMINUM ALLOY 6063

M. Safari^{1*}, J. Salimi², S. Hamidipour³

^{1,2,3} Department of Mechanical Engineering, Arak University of Technology, Arak
38181-41167, Iran

ABSTRACT

In this paper, hydro-forming process of stepped tube is studied experimentally and numerically. The material is aluminum alloy 6063. A new bush driving mechanism has been used in the tube hydroforming die set and consequently a stepped tube with sharp corners and high expansion ratio can be produced. In order to more investigation, effects of some process parameters such as internal pressure, die stroke and friction coefficient on the wall thickness of manufactured specimen and die filling are surveyed. The results show that the die is better filled with an increase in the die stroke and internal pressure due to more material flow into the die corners. It is concluded that the reduction of wall thickness is increased with increasing the die stroke, internal pressure and friction coefficient because of more contact surface area of the tube with the die and consequently more friction force in the contact pairs.

KEYWORDS: Hydroforming Process, Stepped tube, Experimental and numerical investigation

1.0 INTRODUCTION

Automotive parts currently under development or in production include seat frames, engine cradles, rails, exhaust manifolds and space frame components. Interest in the tube hydroforming process by the automotive industry is due to the possibility of replacing many multi-piece stamped and welded assemblies in body, frame or chassis components with one-piece hydroformed components. Thus, there is a great potential for not only weight saving but also for tooling and labor cost saving that may occur due to the elimination of multi-stage stamping and assembly processes through part consolidation. Additional benefits of tube hydroforming over stamping are improved dimensional accuracy, improved structural strength and stiffness, and consistent dimensional repeatability (Dohmann & Hartl, 1996), (Smith et al., 2003), (Stoughton & Yoon, 2004).

In recent years, pre-form processes such as bending, crushing and mechanical forming during the hydro-forming process have been used in order to produce a part with required mechanical properties or complex shapes. With these mechanical operations

* Corresponding author email: m.safari@arakut.ac.ir

before or during the hydroforming process, required hydroforming pressure is decreased and also a part with more uniform thickness distribution can be produced. In recent years, many researches have been reported in the field of tube hydroforming process (Kim & Hwang, 2002), (Tabatabaei et al., 2013).

(Kim et al., 2017) studied the finite element modeling of the hydroforming process for niobium tubes intended for use in superconducting radio frequency (SRF) cavities. In their work, crystal plasticity (CP) model was constructed that included the evolution of crystallographic orientation during deformation as well as the anisotropy of tubes in all directions and loading conditions. The results showed that high quality predictions of the deformation under hydroforming of Nb tubes can be obtained using CP-FEM based on their known texture and the results of tensile tests. (Shi et al., 2017) studied the necking and fracture in hydroforming of tubes under internal pressure through using the GTN model numerically. They investigated the effect of superimposed hydrostatic pressure on necking (both uniform stain and localized necking), fracture initiation and fracture surface formation. Their results showed that superimposed hydrostatic pressure has a great impact on the onset of fracture with the increase of superimposed hydrostatic pressure, but insignificant influence on the uniform strain. (Hashemi et al., 2015) predicted bulge height of aluminum tubes AA6063 using ductile fracture criteria at high temperatures. They calibrated ductile fracture criteria by performing several uniaxial tensile tests at different temperatures and strain rates. Free bulging process of tubes was simulated using finite element method and different loading curves were used to bulge the tubes. In their work, prediction of ductile fracture was compared with the experimental results measured on a warm free bulging set-up. Their results showed that Ayada ductile fracture criterion was able to predict the bulge height of aluminum tubes at high temperatures. (Hajializadeh & Mashhadi, 2015) investigated the finite element analysis of impulsive hydroforming on the sheet and tube using an explicit scheme.

The studied the effect of discharge energy, die radius and friction coefficient. It was observed that the discharge energy value has major effect on the process and the friction coefficient has minor effect relative to the others. Their results showed that Al6061-T6 tube did not sustain any damage even by experiencing stresses near the ultimate strength stress due to the high strain rate of the process. (Bihamta et al., 2015) optimized the variable thickness tube drawing and two-step bending in tube hydroforming process in order to obtain parts without any problems like bursting or un-filled zones at the end of the forming processes. (Liu et al., 2014) studied austenite-to-martensite transformation and microcrack initiation and propagation of the tube during T-shape hydroforming using electron backscattering diffraction, scanning electron microscopy, and transmission electron microscopy. The results showed that compared to the compressive stress, metastable austenite with similar strain surrounding or inside the grains transformed easier under tensile loading conditions. The inclusions were responsible for microcrack initiation. The propagation of the cracks was hindered by martensite/austenite constituent due to transformation induced plasticity effect. (Cui et al., 2014) studied the effect of external pressure on the critical effective strain theoretically, numerically and experimentally in order to explore the deformation behavior of double-sided tube hydroforming in square-section die. It was shown that increasing of external pressure has an effect on the fraction of grain boundaries, the number and size of the microvoids and the microhardness in the transition zone, and

thus increases the critical effective strain in the transition zone. It was concluded that the deformation ability of the transition zone is improved by the external pressure in double-sided tube hydroforming of square-section.

One of the main limitations in tube hydroforming process is production of stepped tubes with sharp corners and also high expansion ratios (*Expanded tube diameter/Initial tube diameter*). For production of stepped tubes with sharp corners or high expansion ratios, high forming pressures are needed. Using high pressures, necking and tearing are occurred in the produced part. Therefore, production of stepped tubes with sharp corners of high expansion ratios is very difficult in industries. In recent years some researchers have focused on hydroforming process of stepped tubes with sharp corners. (Kridli et al., 2003) investigated the thickness variation and corner filling in tube hydroforming process. Using commercial finite element code ABAQUS/Standard they simulated two-dimensional plane-strain finite element models of the tube hydroforming process. The interaction of material properties and die geometry on the selection of hydroforming process parameters was examined. It was concluded that the thickness distribution is a function of the die corner radius and strain-hardening behavior of the material. In addition, the thickness variation distribution could be reduced if a larger corner radius was used. (Hwang & Chen, 2005) have examined the die filling in a square cross sectional die by analytical, numerical and experimental methods. It was proved that higher pressure was required to fill the die corner if the corner radius was decreased. (Loh-Mousavi et al., 2007) have studied the filling of the die corner in hydroforming of a tube with box die and a T-shape die. A pulsating pressure path was used to improve the die filling. Although this path could improve the filling of the die corners, but the dies were not filled completely. On the other hand, producing a pulsating pressure path is very difficult than linear on constant pressures.

As it was mentioned above production of stepped tubes with sharp corners of high expansion ratios is very difficult and therefore there has been done few researchers in this field. However, in this paper a new mechanism is proposed for production a stepped tube with sharp corners and high expansion ratio. Using this new mechanism, bending process is associated with hydroforming process and combination of these two forming processes leads to production of a stepped tube with desirable features. In addition, the effects of some process parameters such as internal pressure, friction coefficient and die stroke on the thickness distribution of produced stepped tube and also filing of die is investigated.

2.0 EXPERIMENTAL WORK

The tubes were made of aluminum alloy 6063, and have 5 mm thickness, 26 mm outside diameter, and 170 mm length as initial dimensions. In Figure1, the schematic view of hydroformed tube with its dimensions is shown.

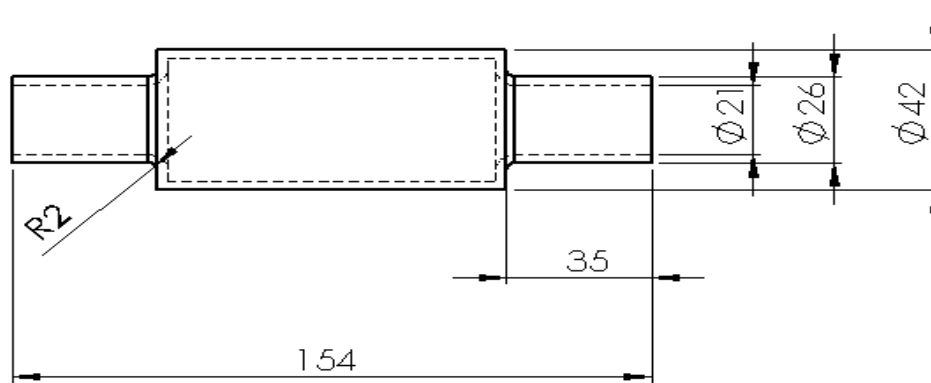
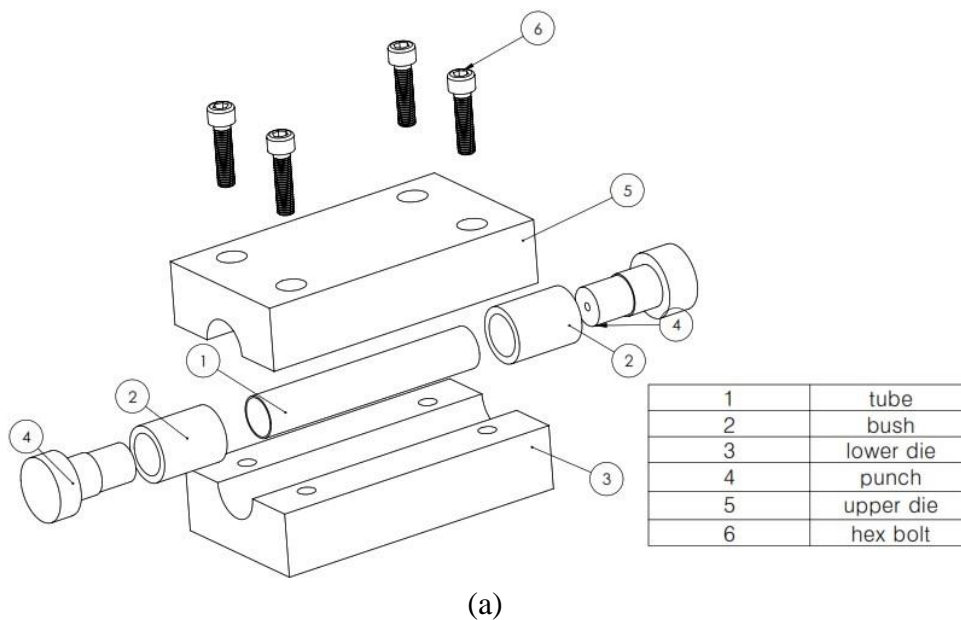
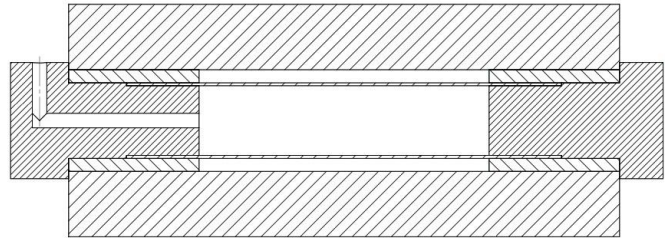

Figure 1. Schematic view of final hydroformed tube with its dimensions

A conventional hydroforming die for stepped tubes is composed of two halves. After placing the tube in the lower die, the upper and lower dies are closed, the tube is filled with liquid, and the punches seal the tube. By applying simultaneously the internal pressure and axial feeding, the tube is formed into the shape of the die cavity. However, with the conventional dies, at the end of the process, the corner of the cavity was not filled completely. In Figure 2 the schematics of die set for hydroforming of stepped tube are shown. It should be noted that the die set contains two additional bushes, compared with the common tube hydroforming dies [9-13].





(b)

Figure 2. (a) The die set for hydroforming of stepped tube, (b) Cut-out view of the die with positioning the tube

The forming stages of the tube in this die set is such that initially the tube is placed in the die, filled with liquid, and sealed with the punches. Then, by increasing the internal pressure, the tube is bulged and contacts the die walls that are fixed. By maintaining the internal pressure, the two bushes move until the die cavity is filled completely. It should be explained that in the common dies, the punches that are in contact with the tube ends, exert the axial feeding on the tube and the die corners cannot be filled completely. However, in the proposed die set in each side of the tube, even though the punch is similarly in contact with the tube end, but the bush gradually contacts the tube. At the end of the forming stage, both the punch and bush will be in complete contact with the tube and will exert axial feeding on the tube. This will lead to complete filling of the die corners. Figure 3 shows the die set mounted on the test machine. As it is seen in Figure 3, in this work a single action universal press machine 250 KN is used. However, in order to hydroforming a stepped tube a press machine with double action is needed. For this purpose, using a new mechanism, single action of press machine is converted to double action. The pressure generating system was a hydraulic unit with a maximum capacity of 30 MPa. The working pressure is regulated by a pressure relief valve. In the FEM simulation, it was necessary to introduce the true stress-strain curve of the tube material. Thus, tension tests are performed. Figure 4 shows the true stress-strain curve obtained for the material. In Figure 5, hydroformed stepped tube with the proposed die is shown. As it is shown in this paper, using the proposed die set a stepped tube with approximately sharp corners can be produced.



Figure 3. The die set mounted on the test machine

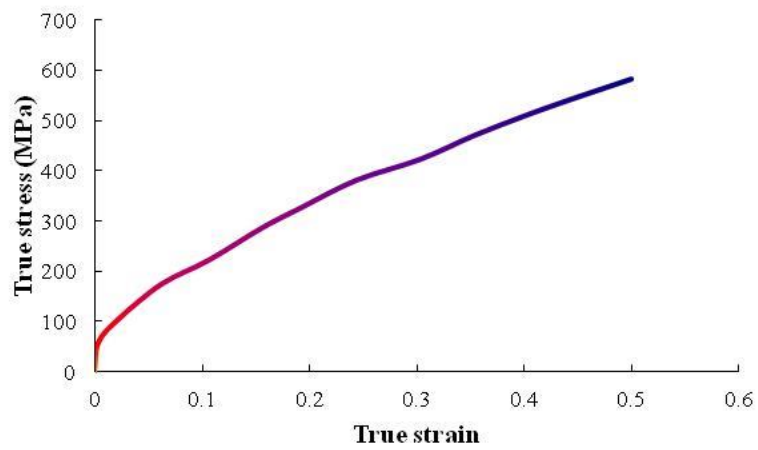

Figure 4. The true stress-strain curve obtained for aluminum alloy 6063 tube



Figure 5. The hydroformed stepped tube with the proposed die and mechanism

3.0 NUMERICAL WORK

In order to simulate the hydroforming process of stepped tube, commercial software, ABAQUS 6.14 is used. The simulation conditions, such as boundary conditions, interactions, internal pressure and loading paths are modeled as same as experiments. It should be noted that due to axial symmetry of parts and simulation conditions, 2D model is simulated in finite element method. The tube is modeled as a 2D axisymmetric with CAX4R element. The die components are modeled as 2D axisymmetric analytical rigid elements. Based on reference [9], the coefficient of friction between the workpiece and the die surfaces is considered to be 0.06 in the simulations. In the numerical simulations, two steps are considered for hydroforming. In the first step, the internal pressure increases until the tube bulges. In the second step, by axial feeding of punches and the bushes, and by remaining the internal pressure constant, the tube completely fills the die cavities. In Figure 6, hydroformed stepped tube in the numerical simulations is seen.

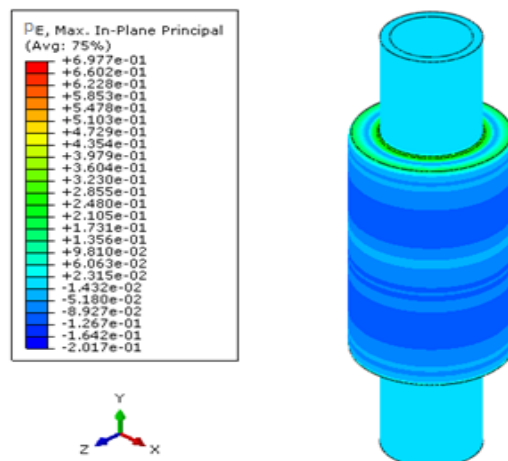

Figure 6. The hydroformed stepped tube in the numerical simulation

4.0 RESULTS AND DISCUSSION

In hydroforming simulations of stepped tube, the mesh size is important. Using coarse elements reduces the accuracy of simulations and very fine elements will increase simulations time without improving the accuracy of results. In order to find an optimum mesh size, internal energy for whole model is calculated at the end of hydroforming process for various numbers of elements (Figure7). From Figure 7, it is concluded that optimum number of elements for these simulations is about 2200 elements.

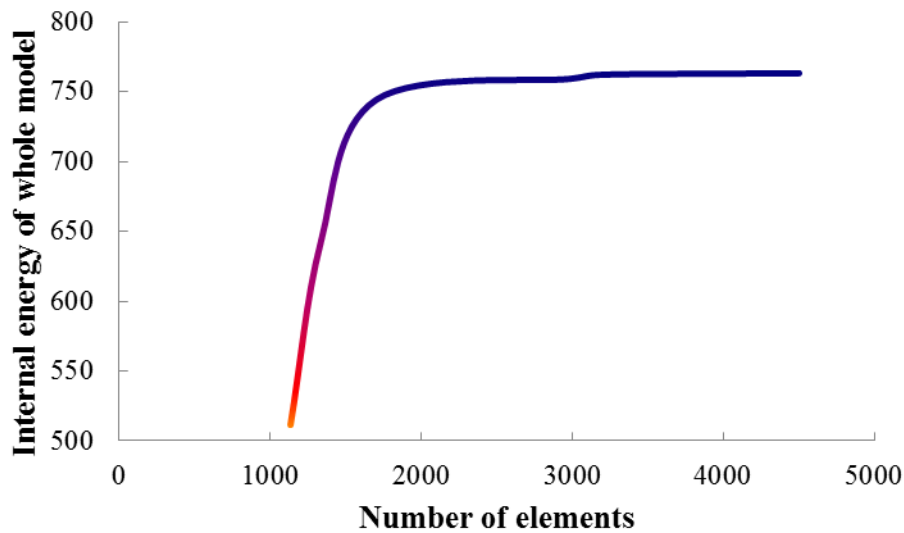

Figure 7. Internal energy of whole model versus number of elements at the end of hydroforming process

In Figure8, thickness distributions of a hydroformed stepped tube that is completely formed in the die obtained from experimental and numerical works are shown. It should be mentioned that for this experiment, the applied internal pressure and die stroke are 118 MPa and 8 mm, respectively.

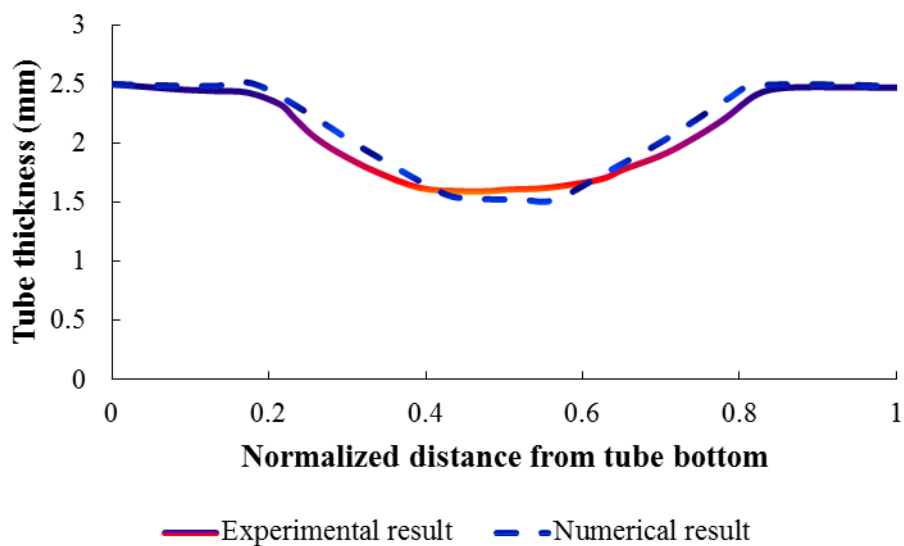

Figure 8. Thickness distributions of a completely hydroformed stepped tube obtained from experimental and numerical works

As it is seen from Figure 8, the thickness reduction in a completely hydroformed stepped tube with sharp corners is approximately 40% in both experimental and numerical results. The results of Figure8 show that the maximum thickness reduction is happened in the expanded area of stepped tube due to effects of internal pressure. In addition, it is proved from Figure8 that there is a good and suitable agreement between experimental measurements and numerical results. As the numerical simulations have been verified with experimental measurements, in the following the effects of some process parameters such as internal pressure, friction coefficient and die stroke on the thickness distribution of produced stepped tube and also die filling are investigated numerically.

4.1 Effect of internal pressure

In order to investigate the effect of internal pressure on thickness distribution and die filling, in the numerical simulations the initial tube will be hydroformed with three different internal pressures. For this purpose five different pressures such as 90, 100, 110, 115 and 118 MPa are applied in the numerical simulations. Axial feeding and friction coefficient are hold as 0.05 and 8 mm respectively. In table 1, the results of die filling and minimum wall thickness for hydroformed stepped tube are presented. The results show that the initial tube cannot fill the die with internal pressures of 90 and 100 MPa. However, the die is partially filled with the initial tube for internal pressure of 110 and 115 MPa and completely filled with the internal pressure of 118 MPa. The reason is that with increasing the internal pressure the material flow into the die corners is increased and hence die is more filled. The results indicated that with increasing in the internal pressure, reduction of wall thickness of stepped tube is increased because of more contact surface area of the tube with the die and consequently more friction force in the contact pairs.

Table 1. The results of die filling and minimum wall thickness of hydroformed stepped tube for different internal pressures

Internal pressure (MPa)	90	100	110	115	118
Filling of die	Not filled	Not filled	Partially filled	Partially filled	Completely filled
Minimum wall thickness (mm)	-----	-----	1.76	1.72	1.69

4.2 Effect of die stroke

In this section, effect of die stroke on filling of the die and minimum wall thickness of hydroformed stepped tube is investigated. For this purpose, five different die strokes such as 3, 5, 6, 7 and 8 mm are considered in the numerical simulations while internal pressure and friction coefficient are hold as 118 MPa and 0.05, respectively. The results of variation of die stroke on filling of the die and minimum wall thickness are presented in Table 2.

Table 2. The effect of die stroke on filling of the die and also minimum wall thickness of hydroformed stepped tube

Die stroke (mm)	3	5	6	7	8
Filling of die	Not filled	Not filled	Partially filled	Partially filled	Completely filled
Minimum wall thickness (mm)	-----	-----	1.93	1.80	1.66

As it is seen in table 2, better filling of the die is happened with an increase in the die stroke. Table 2 shows that the reduction of wall thickness is increased with increasing the die stroke. The material flow into the die is increased with increasing in the die stroke. Therefore, the die is better filled. However, with an interaction between die stroke, internal pressure and friction coefficient and due to increasing in the contact surfaces between die and the tube, more thickness reduction is seen in the manufactured tubes.

4.3 Effect of friction coefficient

In Figure 9, the effect of friction coefficient (between die and tube) on the minimum wall thickness of hydroformed stepped tube is shown. It should be noted that in the investigation of friction coefficient, the internal pressure and die stroke have been adjusted as 118 MPa and 8 mm respectively. In this state, the die can be filled completely by the tube. However, in this section only the effect of friction coefficient of the minimum wall thickness of hydroformed stepped tube is investigated.

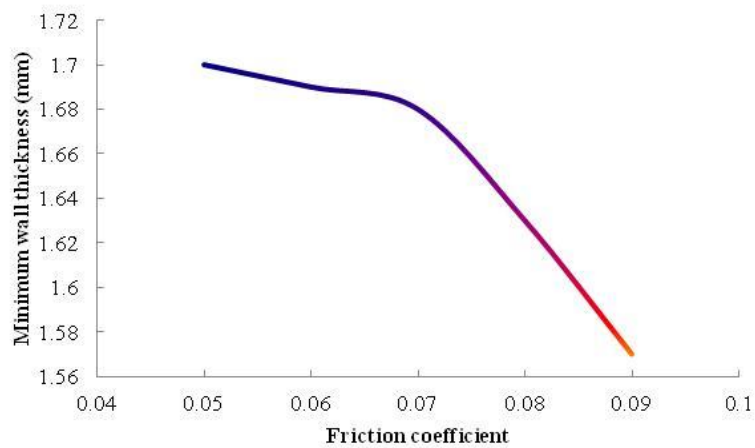

Figure 9. Effect of friction coefficient of the minimum wall thickness of hydroformed stepped tube

As it is seen in Figure9, with an increase in the friction coefficient, reduction of wall thickness of hydroformed stepped tube is increased because of more contact surface area of the tube with the die and consequently more friction force in the contact pairs.

5.0 CONCLUSIONS

In this work, hydroforming process of a stepped tube from of Al 6063 was investigated experimentally and numerically. A new mechanism was proposed for production a stepped tube with sharp corners and high expansion ratio. The effects of some process parameters such as internal pressure, die stroke and friction coefficient on filling of the die and also minimum wall thickness were investigated. The results showed that using the proposed mechanism in this paper, a stepped tube with sharp corners and high expansion ratio could be manufacture. It was concluded that better filling of the die was happened with an increase in the die stroke and internal pressure due to more material flow into the die corners. The reduction of wall thickness was increased with increasing the die stroke, internal pressure and friction coefficient because of more contact surface area of the tube with the die and consequently more friction force in the contact pairs.

6.0 REFERENCES

- Bihamta, R., Bui, Q. H., Guillot, M., D'Amours, G., Rahem, A., & Fafard, M., (2015). Global optimisation of the production of complex aluminium tubes by the hydroforming process. *CIRP Journal of Manufacturing Science and Technology*, 9, 1–11.
- Cui, X. L., Wang, X. S. & Yuan, Sh. J., (2014). Deformation analysis of double-sided tube hydroforming in square-section die. *Journal of Materials Processing Technology*, 214(7), 1341–1351.
- Dohmann, F., & Hartl, Ch., (1996). Hydroforming – a method to manufacture lightweight parts. *Journal of Materials Processing Technology*, 60, 669–676.
- Hajjalizadeh, F., & Mashhadi, M. M., (2015). Investigation and numerical analysis of impulsive hydroforming of aluminum 6061-T6 tube, *Journal of Manufacturing Processes*, 20(1), 257–273.
- Hashemi, S. J., Moslemi Naeini, H., Liaghat, G. H., & Azizi Tafti, R., (2015). Prediction of bulge height in warm hydroforming of aluminum tubes using ductile fracture criteria, *Archives of Civil and Mechanical Engineering*, 15(1), 19–29.
- Hwang, Y. M., & Chen, W. C., (2005). Analysis of tube hydroforming in a square cross-section die. *International Journal of Plasticity*, 21, 1815–1833.
- Kim, H. S., Sumption, M. D., Bong, H. J., Lim, H., & Collings, E. W., (2017). Development of a multi-scale simulation model of tube hydroforming for superconducting RF cavities, *Materials Science and Engineering: A*, 679, 104–115.

- Kim, J., & Hwang, S. M., (2002). Preform design in hydroforming by three-dimensional backward tracing scheme of the FEM, *Journal of Materials Processing Technology*, 130-131, 100-106.
- Kridli, G. T., Bao, L., Mallick, P. K., & Tian, Y., (2003). Investigation of thickness variation and corner filling in tube hydroforming. *Journal of Materials Processing Technology*, 133, 287–296.
- Liu, J., Zhang, Z., Manabe, K. I., Li, Y., & Misra, R. D. K., (2014). Microstructure evolution in TRIP-aided seamless steel tube during T-shape hydroforming process. *Materials Characterization*, 94, 149–160.
- Loh-Mousavi, M., Mori, K., Hayashi, K., & Bakhshi-Jooybari, M., (2007). Improvement of filling die corners in box-shaped tube hydro-forming by control of wrinkling. *Key Engineering Materials*, 334, 461–467.
- Shi, Y., Jin, H., Wu, P. D., & Lloyd, D. J., (2017). Effects of superimposed hydrostatic pressure on necking and fracture of tube under hydroforming, *International Journal of Solids and Structures*, 113–114, 209–217.
- Smith, L.M., Averill, R.C., Lucas, J.P., Stoughton, T.B., & Matin, P.H., (2003). Influence of transverse normal stress on sheet metal formability. *International Journal of Plasticity*, 19, 1567–1583.
- Stoughton, T.B., & Yoon, J.W., (2004). A pressure-sensitive yield criterion under a non-associated flow rule for sheet metal forming. *International Journal of Plasticity*, 20, 705–731.
- Tabatabaei, S. A., Shariat Panahi, M., Mosavi Mashhadi, M., Tabatabaei, S. M., & Aghajanzadeh, M., (2013). Optimum design of preform geometry and forming pressure in tube hydroforming using the equipotential lines method, *The International Journal of Advanced Manufacturing Technology*, 69(9-12), 2787-2792.