

Fuzzy Logic Implementation for Power Efficiency and Reliable Irrigation System (PERIS) of Tomatoes Smart Farm

Francisco B. Culibrina and Elmer P. Dadios

University of Rizal System, Morong, Rizal 1960 Philippines

De La Salle University, 2401 Taft Avenue, Malate, Manila 1004 Philippines

francisco_culibrina@dlsu.edu.ph

Abstract—This paper presents an intelligent motor speed controller for Three Phase Motor with Variable Frequency Driver (VFD) for irrigation system of Smart Farming using fuzzy logic algorithm developed inside a Micro-Control Unit (MCU) environment or MCU on Power Efficiency and Reliable Irrigation System (PERIS). The desired motor speed controller is obtained using fuzzy inputs that consider three phenomenon such as: availability of energy within the system, reservoir water level and environment temperature. These fuzzy inputs are feedback data from the water reservoir level sensor (plant water requirements), environment/temperature sensor and current sensor. Different frequencies were used to test the controller's performance in real time undergoing different water level and power load variations. The whole system is powered by photovoltaic cells, it can quickly and accurately calculate water demand amounts of crops, which can provide a scientific basis for power-savings and water-savings for irrigation. Experiment results showed that the developed controller is efficient, reliable and robust.

Index Terms—Fuzzy Logic; Irrigation System; Micro-Control Unit; Motor Speed Control; Smart Farm; Three Phase Motor.

I. INTRODUCTION

Food security is a major problem the world faces today [1]. The effect of global warming coupled with the world population explosion poses a big challenge to solve this problem. The unpredictable weather conditions evidently destroyed agricultural products [2]. In addition, due to climate change, the power/energy generation is compromised that resulted in crops water irrigation problem [3]. As a result, decreasing of agricultural products such as rice, corn, tomato, etc. was sentient by the farmers especially during offseason. Tomato was considered as one of the most cultivated vegetables around the globe and it is extensively grown as secondary crop from rice and corn based farming system. [4]. Consumption of tomato continues to increase around the globe [5].

To address the increasing demand of tomato, year round tomato production is the answer, thus, environment real time monitoring and water management are the important things to consider in smart farming. In this research, the focus of smart farming is to use new technology using fuzzy logic control to be program at MCU to drive VFD for motor control system that can give continuous site-specific plant production with consideration of environmental temperature, power availability and reservoir water level.

Plant grow are directly affecting by both factor of environment and water management [6]. Different real time monitoring for irrigation system were introduce by various researcher [7,8,9] but without consideration of power availability and environment temperature. Motor control management are necessary for power efficiency of the system [10]. Variable motor speed result into non-linear condition, thus, this involves the use of mathematical modeling to solve and understand complex nonlinear problems during motor operation [11], [12]. The uniqueness of this system is that, by using fuzzy logic developed in MCU, new circuit design of Input / Output (I/O) module & 12Vdc power supply that can provided an intelligent learning for power management and irrigation system as seen in Figure 1. By using photo voltaic cell as a source of energy, these can be install and use at any remote and isolated farm even without availability of commercial power.

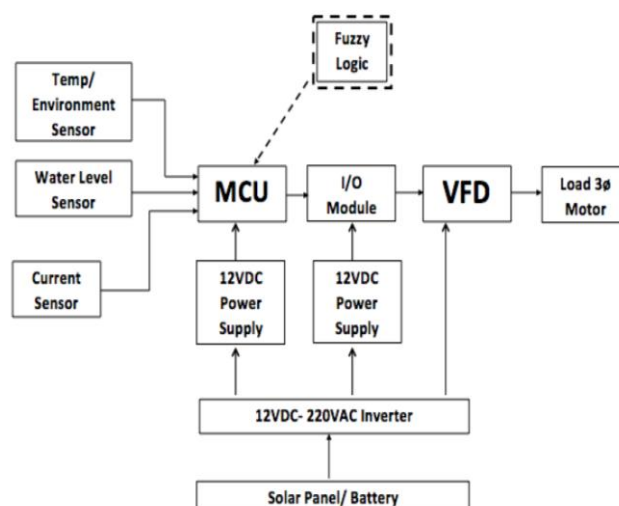

Figure 1: Block diagram for Power Efficiency and Reliable Irrigation System (PERIS) for Smart Farming for Tomatoes

II. POWER AND WATER SOURCE GENERATION FOR THE TOMATOES SMART FARMING

A. Water Source Generation

Deep irrigation must prefer for tomato and it seems semi-regular rather than light, daily irrigation [13]. One to two inches or one gallon of water each week are the basic requirements of each tomato plants, but more accurately one gallon of water for five days [14]. Infrequent or irregular

irrigations for tomato plant resulting to stress and growth development problems, including blossom end rot and cracked or split fruit [15]. It is required to maintain a minimum of 25 psi on water supply to have a good performance for automatic sprinkler irrigation and drip irrigation [16]. To address this needs, constant water supply must retain. These can be done using automated Jack Pump Well, driven by one horse power (1HP) three phase motor as shown from Figure 1 and Figure 2.

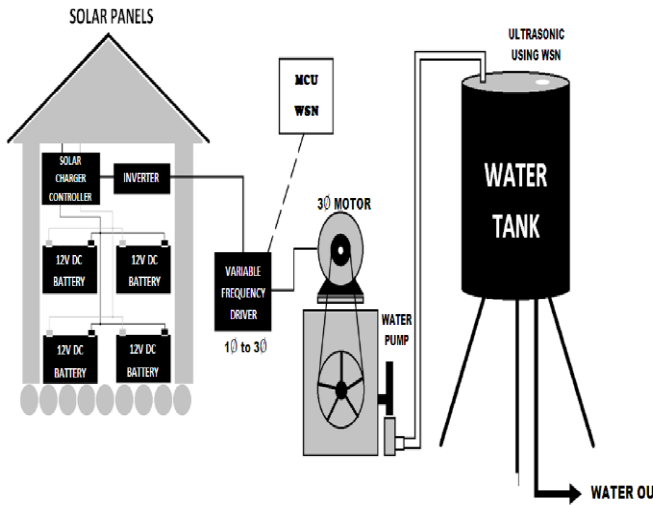

Figure 2: Cross section view of Smart Farm Solar Power and Irrigation System with an actuator using MCU, WSN and VFD.

Three phase motor was triggered and drove by VFD to provide different frequencies for one horse power-three phase motor to allow nonlinear speed requirements for the motor, these can be seen on Figure 1. Varying the speed of inductive motor will result to savings of energy consumption in the system [17]. The VFD was depend on the signal coming from MCU, where the fuzzy logic program developed. It has a three nonlinear input variables such as; (a) different levels of water reservoir/tank, (b) Environment Temperature, and (c) Availability of Energy in the System.

Since the three phase motor are operated in 220VAC, it will give an effect of electrical spike on other parts of the circuit in the system that will result to intermittent function of signals. Thus, to eliminate these effect of electrical spike, the researchers designed a novel I/O module that specific for these application to connect MCU and VFD without any interfering of electrical spikes on the other parts of the circuits, this can be seen at Figure 3.

The circuit I/O module on Figure 3 uses Opto-Isolation that allows transmission of information between two circuits, without making an electrical connection between them. Instead, the information transmitted as light. These serves as peripheral bridge between the MCU having a fuzzy logic program and VFD that drove the three phase-one horse power (1HP) inductive motor. It uses photo-transistors to separate electrically both side of the circuit from MCU to VFD, but connected by means of light signal from the photo-transistor.

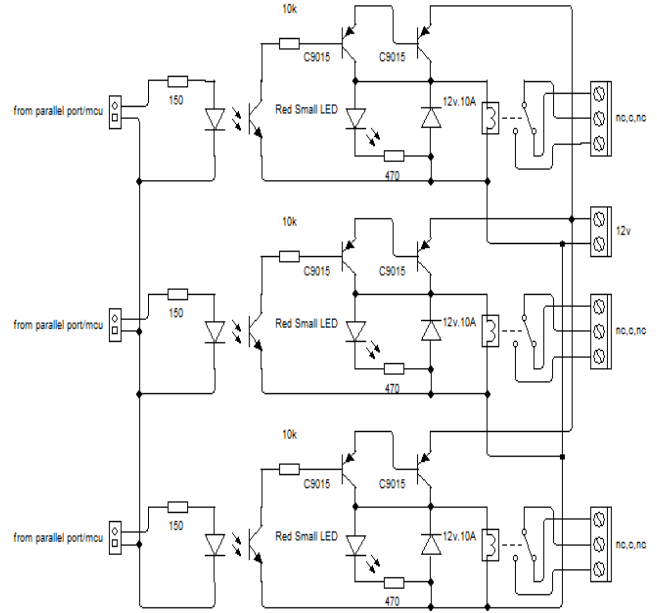

Figure 3: Present the configured system hardware schematic diagram of Input / Output (I/O) module.

Designing for this circuit at any application can be possible by choosing appropriate resistor values. Using KCL at the microcontroller pin can do so. The pin itself draws zero current, because it is an input, and the capacitor draws zero current at DC. Turning conductance instead of resistance can be apply to make it easier approach using mathematical computation, $G_1 = 1/R_1$, $G_2 = 1/R_2$, and $G_3 = 1/R_3$. The KCL gives:

$$\begin{aligned} (V_{adc}-5)/R_3+(V_{adc}-V_{measured})/R_1+V_{adc}/R_2 &= 0 \\ G_3 \times (V_{adc}-5)+G_1 \times (V_{adc}-V_{measured})+G_2 \times V_{adc} &= 0 \\ (G_1+G_2+G_3) \times V_{adc} &= G_3 \times 5+G_1 \times V_{measured} \end{aligned} \quad (1)$$

$$V_{adc} = (G_1/(G_1 + G_2 + G_3)) \times V_{measured} + (G_3/(G_1 + G_2 + G_3)) \times 5$$

B. Irrigation System

This study use both sprinkler and drip irrigation system that can be seen at Figure 4. The water reservoir/tank used can store 1500 liters of water. For this study, maintaining 25 psi of water supply was required to give good operation performance for automated drip irrigation and sprinkler irrigation system. Thus, to maintain 25 psi, equation 2 used for computation and it will give the result of having a minimum content of 1000 liters of water in water reservoir.

In getting the water psi of this study, considering formula shown below. One pound per square inch (psi) of pressure can be created using a 1-in. square column of water nearly 28 inches or 2.31 feet high. This is calculated from the two relationships developed [18].

$$\begin{aligned} \frac{1 \text{ psi}}{x \text{ inches}} &= \frac{0.036 \text{ psi}}{1 \text{ inch column}} \\ 0.36x &= 1 \\ x &= 2.77 \text{ inches} \\ \frac{0.433 \text{ psi}}{1 \text{ foot column}} &= \frac{1 \text{ psi}}{x \text{ feet}} \\ 0.433x &= 1 \\ x &= 2.31 \text{ feet} \end{aligned}$$

Because pressure changes with differences in elevation, two useful relationships to consider are:

1 foot of water = 0.433 pounds per square inch pressure
 2.31 feet of water = 1 pound per square inch pressure

$$psi = 0.433 \times height \text{ in feet} \quad (2)$$

Temperature requirements for tomato are between 14 degree to 24 degree Celsius [19]. Sprinkler irrigation system was not only for watering the plant but also to help lowering the temperature and humidity from 4.5 percent to 7 percent of temperature for a certain area [20], while drip irrigation used to increase the soil moisture content of plant plot. Figure 4 shows actual irrigation system implemented using both drip irrigation and sprinkler irrigation. Using soil moisture sensor allows to trigger the solenoid valve to on/off state for drip irrigation system, while the temperature sensor allows to trigger the solenoid valve for sprinkler irrigation system. In these study, the researchers also experiment and observe to determine the specific effect of rainfall warning to content of soil moisture. It was conducted using cylindrical container with 20cm diameter and 20cm depth containing of soil, by applying the precipitation value of water will give the result of soil resistance and memory require as shown in Table 1, this table use as reference for indoor (drip and sprinkler) application and outdoor (with rainfall). Also, to determine exact value of precipitation needed to be applied by the drip irrigation.

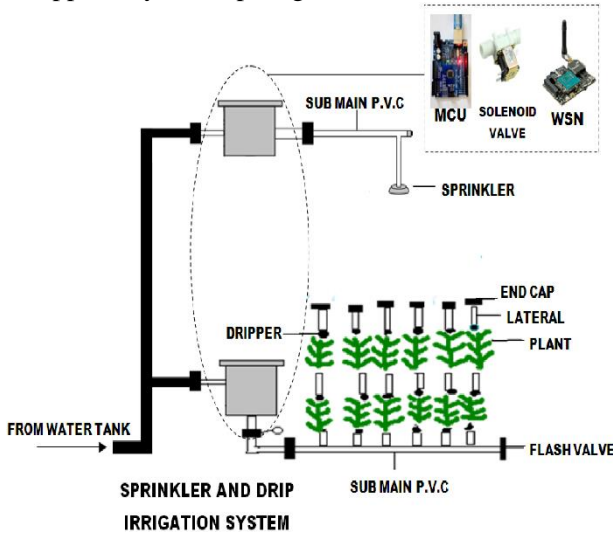

Figure 4: Sprinkler and Drip Irrigation System with solenoid valve, MCU and WSN

Table 1
 Rainfall warning with corresponding precipitation, soil resistance and memory requirements

Rain Warning	Precipitation (mm)	Soil Res. (Ω)	Byte (kB)
	0 - 2.5	3M	770
white	2.5 - 5	1.57M	660
	5 - 7.5	340k	505
	7.5 - 10	310k	500
yellow	10 - 12.5	160k	490
	12.5 - 15	145k	437
	15 - 17.5	135k	426
	17.5 - 20	120k	425
orange	20 - 22.5	105k	424
	22.5 - 25	80k	414
	25 - 27.5	30k	402
	27.5 - 30	5k	399
red	30 >	700	397

Table 1 serves as a reference for the soil moisture sensor to trigger the solenoid valve for drip irrigation. It was found out using equation 3 that drip irrigation operates and triggered at the range of 0-7.5mm of precipitation of water.

$$Consumption(mm) = 1 \text{ tomato} \times \left(\frac{1 \text{ gallon}}{5 \text{ days tomato}}\right) \times \left(4 \frac{\text{liters}}{\text{gallon}}\right) \times \left(\frac{1 \text{ mm}}{1 \times 10^{-6} \text{ liter}}\right) \quad (3)$$

C. Electric Power Source Optimization

These research use and promote renewable energy, in Figure 2 shows that the main source of power came from solar energy. It consists of 10 pcs (100 watts each) solar panel having a total of 1kWatts, with 4 pcs. of storage battery (12 Volts/100Ah) connected in parallel to the 12Vdc to 220Vac inverter. It support power operation for 1HP (746Watts) three phase induction motor, MCU and VFD as shown in Figure 1. Thus, optimization of power in the system was required to maximize the operation. In this paper, a three phase one horsepower (1HP or 746Watts) induction motor was used to pump and generate water from a deep well. Using three phase induction motor, it will give more power efficiency consumption compared to single phase induction motor [21].

Three phase induction motor switch into ON/OFF having different frequency controlled by means of MCU with a program of fuzzy logic. Table 2 shows the average value of Output Power (Po), Power Loss (Pl) due to core, switch, heat, etc., and Input Power (Pi) from Table 2 of single phase and three phase motor. Comparison of power efficiency for single phase and three phase motor are computed using formula given from the table.

To fill up the water tank/reservoir, it is require to run the induction motor into 6 hours within a day, succeeding day need 2 hours to maintain a minimum of 25 psi water pressure as discussed from 2.1.1, these will result to an average of 1hour and 8 minutes operation of motor per day.

Table 2
 Efficiency (η) of Single Phase vs Three Phase

Motor	Use formula	Computed Ave. value	Efficiency
Three Phase	$\eta = \frac{P_o - P_l}{P_i} \times 100\%$	Po=264, Pl=2.14, Pi=285	92.07%
Single Phase		Po=426, Pl=2.78, Pi=615	68.85%

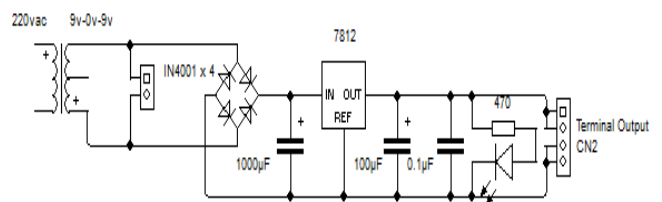

Figure 5: Schematic Diagram of 12V Regulated Power Supply MCU & I/O Module

Figure 5 shows the designed of a 12Vdc power supply dedicated for MCU and I/O special purposes to eliminate the effect of electric spike on the circuits due to the use of induction motor. To ensure the filter of signal, it uses 1000µF capacitor after the rectifier connected in parallel and another 100µF & 0.1µF capacitor after IC-7812 regulator also connected in parallel.

III. PROCESS INVOLVED IN FORMULATING THE FUZZY-MCU FOR POWER OPTIMIZATION & WATER SOURCE GENERATION

A. Fuzzy-MCU Process Flow

Figure 6 show the process flow of fuzzy control implementation to power optimization and water source generation using MCU. The main condition references of motor speed are the value of Available Energy (AE), as seen from Table 3. Available Energy are categorized as; Stop (S) ≤ 50 , Extremely Low (EL) from 60%, Low (L) from 70%, Medium (M) from 80%, and High (H) from 90% >. Another input, process value (water level and Temperature) that obtained as the feedback value of variable frequency drive (VFD). VFD is a device used to control AC motor speed and torque by varying its input frequency and voltage [22].

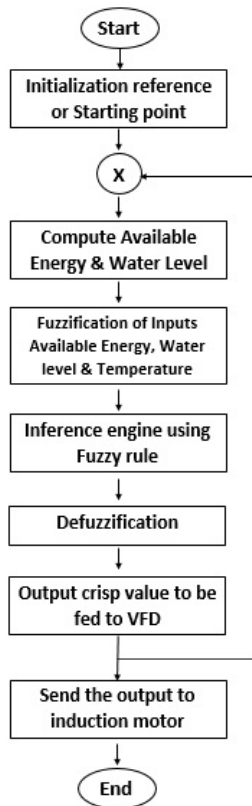

Figure 6: Fuzzy control flow chart diagram.

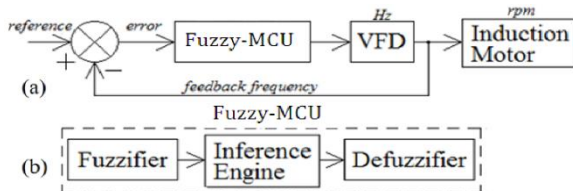

Figure 7: Components of Fuzzy-MCU controller. (a) Proposed-MCU based fuzzy controller; (b) components of the fuzzy-MCU controller.

Figure 7 shows the main components of Fuzzy-MCU controller. In this setup, the micro-controller unit (MCU) served as the main controller where the fuzzy logic algorithm was programmed. Fuzzy control (see Figure 7b) consists of fuzzifier, inference engine and defuzzifier [23], [24]. The water pump is electrically actuated by three phase 1-HP induction motor driven by the VFD.

Table 3
Fuzzy Rules for Available Energy, Temperature and Water Level.
ES=Extremely Slow, S=Slow, M=Moderate, H=High

Condition		Energy Level (%)			
Temperature (T)	Water Level (WL)	60 (EL)	70 (L)	80 (M)	90> (H)
Input Variable		Motor Speed Output			
Low	Low	ES	S	M	M
Low	Med.	ES	S	M	M
Low	High	ES	S	M	M
Med.	Low	ES	M	M	H
Med.	Med.	ES	M	M	H
Med.	High	ES	M	M	H
High	Low	S	M	H	H
High	Med.	S	M	H	H
High	High	S	M	H	H

B. Fuzzy Inputs

The researchers use the fuzzy MultipleXer (fMUX) as shown on Figure 8 to minimize the fuzzy rules, from 27 fuzzy rules into 9 fuzzy rules, input variables into Temperature (T) and Water Level (WL). A fuzzy multiplexer or (fMUX) acts as a fuzzy switch to select one of the fuzzy inputs. Selection of the inputs is determined by the value of candidate inputs termed as “Select Inputs” [25]. Available Energy are categorized as; Stop (S) from 0 to 50%, Extremely Low (EL) from 60%, Low (L) from 70%, Medium (M) from 80%, and High (H) >90% as shown from Table 3. The three phase induction motor for water pump are in OFF state at 50% and below ($\leq 50\%$) of the Available Energy. Using the Table 3 for fuzzy rules, the induction motor will turn ON at approaching 60 percent and above ($\geq 60\%$) base providing different motor speed base on condition of Temperature and Water Level as shown.

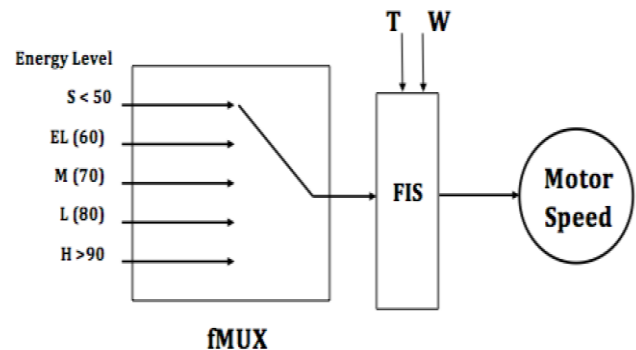

Figure 8: Fuzzy Control Block Diagram using fMUX for input selection of Available Energy level, considering the Temperature (T) and Water Level (WL)

C. Design of fMUX

Figure 9 shows block diagram of fuzzy multiplexer (or fMUX). The function of fMUX can selects one of several analog or digital input signals and forwards the selected input into a single line using selection logic provided by select lines. The basic fuzzy multiplexer, fMUX, realizes fuzzy multiplexing by the general expression [26].

$$Z = (EL * \bar{S}o * \bar{S}1) + (L * \bar{S}o * S1) + (M * So * \bar{S}1) + (H * So * S1) \quad (4)$$

where the logic operations (* and +) are implemented using some So and S1.

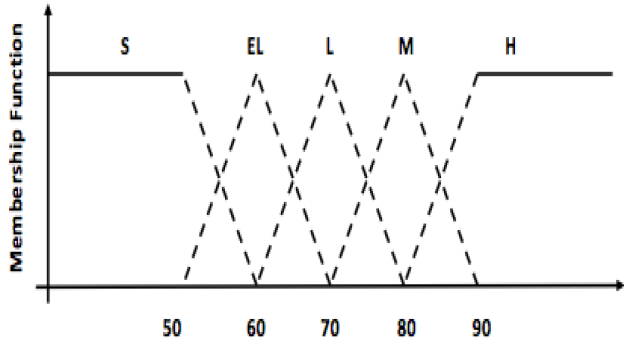

Figure 9: Fuzzifier using five (5) membership functions (S, EL, L, M and H).

IV. EXPERIMENT RESULTS

Table 2 and Table 3 shows the summary of input voltage V_i , input current I_i and computed input power P_i having a formula from equation 5, with additional constant of 1.4 for inverter loss. Output voltage V_o and output current I_o and computed RMS output power of P_o having formula of Equation 6 and computed value of system efficiency using the formula of Equation 7.

$$P_i = V_i \times I_i + 1.4 \quad (5)$$

$$P_o = V_o \times I_o \times \sqrt{3} \quad (6)$$

$$\eta \% = \left(\frac{P_o - P_L}{P_i} \right) \times 100 \quad (7)$$

Using three phase induction motor with VFD and MCU, C language for coding the program and adopting the fuzzy control flow chart diagram from Figure 6, implementing the fuzzy rules from Table 3. The responds of motor can be seen at figure 11, it indicates that the energy usage or consumptions for the whole system for irrigations are very minimal. Using the formula from equation 6 for getting the energy consumption calculation, energy E in kilowatt-hours (kWh) per day is equal to the power P in watts (W) times number of usage hours per day t divided by 1000 watts per kilowatt,

$$E_{(kWh/day)} = P_{(W)} \times t_{(h/day)} / 1000_{(W/kW)} \quad (8)$$

Using formula from Equation 8, having parameters of: inverter to convert DC to AC efficiency is 90%; power factor of the Operating Induction Motor is 0.85 (The power factor of induction motors varies with load, typically from around 0.85 or 0.90 at full load to as low as 0.35 at no-load, due to stator and rotor leakage and magnetizing reactance); Line to

line Voltage 400V and Frequency be 60Hz, star winded Stator; motor full load efficiency is 85% (Full load motor efficiency varies from about 85 % to 97 %, related motor losses being broken down roughly as follows: Friction and windage5%–15%, Iron or core losses, 15%–25%, Stator losses, 25%–40% Rotor losses, 15%–25% Strayloadlosses, 10% . Using Table 1 experiment, the results for initial energy consumption computation for the irrigation system to fill the tank are 3.73kW-hr/day. To maintain 500 liters of water as mentioned earlier, the energy requirements for the system is 1.24kW-hr/day.

V. DISCUSSION AND ANALYSIS OF RESULTS

The testing was performed in the irrigation system at Smart Farm for Tomato situated at Sitio Ugat, Brgy. Maybancal, Morong, Rizal as seen in figure 2a. The previous system were used conventional or manual switching system and it used a 1hp single phase induction motor. Figure 10 show the line graph of current consumption for both MPPERIS and conventional system. It is notice that conventional system required high amount of current for starting process for single phase induction motor. It has also an average current consumption of 8.1 amperes, which is very high compare with MPPERIS. Using Variable Frequency Drive (VFD) for this system made possible to use three phase induction motor and implementation of fuzzy logic to maximize the percentage of energy savings. It is possible even if the supply coming from photovoltaic cell (solar panel), the system can manipulate the starting revolution per minute (rpm) of motor by gradual increasing of frequency (Hz) from 0Hz to 60Hz induced in three phase induction motor, since the rpm of motor are direct proportionally related to frequency, the current requirements are resulting into very minimal value. It is also noticed that the current consumption of MPIRES had an average of 2.0 ampere, while the Conventional system had an average of 8.1 ampere, this can be seen on Table 4. The graph also show that the out MPIRES are in linear while conventional system are non-linear.

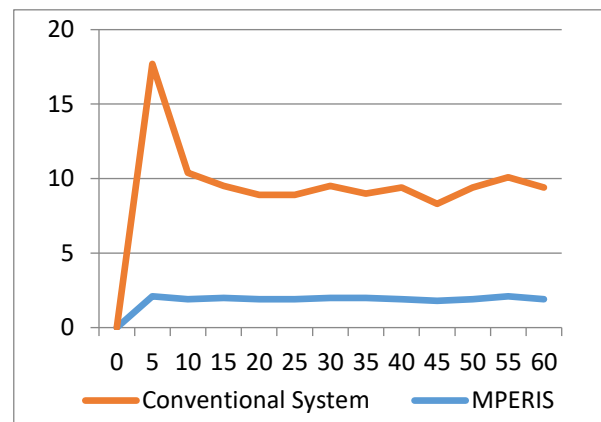

Figure 10: Line graph of current consumption for PMSEIS and Conventional System

Table 4
% Savings and Current Consumption of MPSEIS and Conventional System

Times (s)	0	5	10	15	20	25	30	35	40	45	50	55	60
PMSEIS	0	2.2	2.1	1.9	1.8	1.7	1.9	2	2.1	2.2	1.8	2.1	2.2
Conventional	0	15	12	9	6.8	6	6.5	6.8	7	7.3	6.5	6.9	7.1
% Savings	0	85.3	82.5	78.9	73.5	71.7	70.8	70.6	70.0	69.9	72.3	69.6	69.0

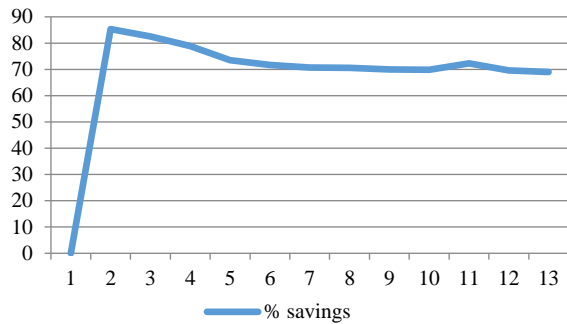

Figure 11: Percentage Savings of Current

Percentage current are calculated based on the Equation 9, where in the average current savings was computed equal to 73.7% compare from the conventional system.

$$\%savings = \frac{Con. Current - MPSEIS Current}{Con. Current} \times 100 \quad (9)$$

Figure 12 shows the line graph comparison of percentage efficiency of the two systems. The MPERIS has an average efficiency of 90.55 percent and conventional system has an average efficiency of 59.98 percent. MPERIS has an advantage of almost 30.57 percent of efficiency for the whole system.

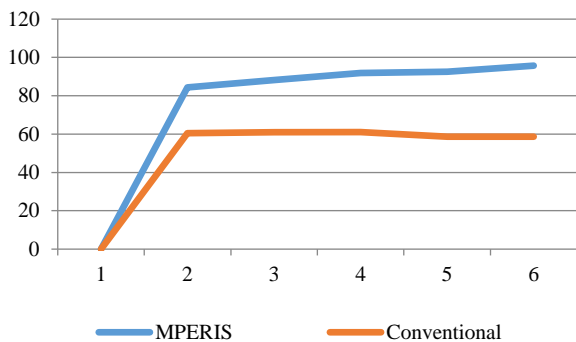

Figure 12: Percentage Efficiency Comparison of MPERIS and conventional system.

VI. CONCLUSION AND RECOMMENDATIONS

Using of VFD and MCU with the implementation of fuzzy logic-based motor speed controller into Irrigation system was obviously successful. Results showed that the fuzzy controller is significantly better compared to the conventional controller in terms of handling load variations.

It is also appreciate the use of fuzzy logic for enhancing the capabilities of the MCU in providing intelligent automation process. Results showed that the developed controller is accurate, reliable and robust by providing a percentage savings of current usage which is 73.7 percent..

ACKNOWLEDGMENT

The authors would like to acknowledge University of Rizal System-Morong, De La Salle University-Manila and the Engineering Research and Development for Technology (ERDT) of the Department of Science and Technology (DOST) for the research support and funding.

REFERENCES

- [1] Rosamond Hutt. (2016, January) www.weforum.org. [Online]. www.weforum.org
- [2] Jennifer A. Ng/Reporte. (2016, July) www.pcic.gov.ph. [Online]. www.pcic.gov.ph
- [3] Fritzie Rodrigues. (2014, March) www.rappler.com. [Online]. www.rappler.com
- [4] Patrick Raymud A. Lesaca. (2015, December) www.businessdiary.com.ph. [Online]. [businessdiary](http://www.businessdiary.com.ph)
- [5] Garry Lucier, Biing-Hwan Lin, Jane Allshouse, and Linta Scott Kantor, "Factors Affecting Tomato in the United States," *Vegetable and Specialties (Economic Research Services)*, vol. VGS 282, pp. 26-32, November 2000.
- [6] Francisco B Culibrina and Elmer P Dadios, "Smart Farm Using Wireless Sensor Network for Data Aquisition and Power Control Distribution," in *8th IEEE International Conference on HNICEM, Palawan, 2015*.
- [7] C. Emilio, C. Perez-Lucena, J. Roldan-Canas, and A. Miguel, "IPE:Model for Management and Control of Furrow Irrigation Real Time," *Journal of Irrigation and Drainage Engineering*, pp. 264-269, 1997.
- [8] K. L. Khatri and R. J. Smith, "Real Time Prediction of Soil Infiltration Characteristics for the Management of Furrow Irrigation," *Irrigation Science*, vol. 25, no. 1, pp. 33-46, 2006.
- [9] H. Tural, "Sensor Placement for Real Time Control of Automated Border Irrigation," *Proc. Conf. on Engineering in Agriculture and Food Processing*, p. SEAg 96/036, 1996.
- [10] Mark Steinmetz. (2012, May) www.vincotech.com. [Online]. [vincotech.com](http://www.vincotech.com)
- [11] Pradeep M Patil and Sanjay L Kurkute, "Speed Control of Three Phase induction motor Using single phase supply along with active power factor correction," *ACSE Journal*, vol. 6, no. 3, October 2006.
- [12] F J Borgum and E B G Nijhof, "Inverter Circuit for a PWM Motor Speed Control System," *Electronics Component and Application*, vol. 2, no. 3, p. 130, May 1980.
- [13] National Gardening Association. (2016, January) www.garden.org. [Online]. [garden.org](http://www.garden.org)
- [14] Heather Rhoades. (2016, April) www.gardenigknowhow.com. [Online]. [gardenigknowhow.com](http://www.gardenigknowhow.com)
- [15] VeggieGardener. (2010, April) [veggiegardener](http://veggiegardener.com). [Online]. www.veggiegardener.com
- [16] Irrigation tutorials. (2014, June) irrigationtutorials.com. [Online]. www.irrigationtutorials.com
- [17] Rahman Saidur, Saad Mekhilef, Mian Basharif Ali, and Hussein A. Mohammed, "Application of Variable Speed Drive (VSD) in Electrical Motors Energy Savings," *Renewable and Sustainable Energy*, January 2012.
- [18] Frank R. Spellman. (1998) crcpress.com. [Online]. www.crcpress.com
- [19] Steve Albert. (2010, March) www.harvesttotable.com. [Online]. [harvesttotable.com](http://www.harvesttotable.com)
- [20] Giulio Lorenzini. (2002, October) www.onlinelibrary.wiley.com. [Online]. onlinelibrary.wiley.com
- [21] N. Sclater and J. E. Traister. (2012, April) www.electrical-engineering-portal.com. [Online]. electrical-engineering-portal.com
- [22] S. J. Campbell, "Solid-state AC Motor Control," New York: Marcel Dekker, pp. 79-189, 1987.
- [23] E. H. Mamdani, "Application of Fuzzy Algorithmsfor the control of a dynamic plant," in *IEEE Proc.*, vol. 121, 1974, pp. 1585-1588.
- [24] R. Langari, "Past, present and future of fuzzy control: a case for application of fuzzy logic in hierarchical control," in *18th Int. Conf. of the North American Source*, 1999, pp. 760-765.
- [25] Furqan Fazili, "Fuzzy Logic Based Multiplex Design and Simulation," *IOSR Journal Of Electronics and Communication Engineering*, vol. 9, no. 2, pp. 31-36, March 2014.
- [26] Witold Pedrycz, "Logic-driven Fuzzy Modeling with Fuzzy Multiplexer," *Engineering Applications of Artificial Intelligence*, no. 17, pp. 383-391, 2004.
- [27] Electrical Engineering. (2012, April) [electrical-engineering portal](http://electrical-engineering-portal.com). [Online]. www.eletrical-engineering-portal.com
- [28] Elmer P. Dadios, J. J. C Biliran, Ron-Ron Garcia, D. Johnson, and A. R. B Valencia. *Humanoid Robot: Design and Fuzzy Logic Control Techniques for Its Intelligent Behavios*. [Online]. cdn.intechopen.com
- [29] R. Testezlaf, F. S. Zazueta, and T.H. Yeager, "A Real Time Control for Greenhouse," *Applied Engineering Agriculture*, vol. 3, no. 2, 1997.
- [30] Silke Migdal, Philipp Klug, Antoine Denis, and Heike Bach, "The Addiotional value of hyperpecstral data for smart farming," *2012 IEEE International Geoscience and Romote Sensing Symposium*, pp. 7329-7332, July 2012.

- [31] Nafisa Binte Yousuf, Khosru M. Salim, Rafid Haider, Md. Rajin Alam, and Fatima Binte Zia, "Development of Three Phase Induction Motor Controller for Solar Powered Water Pump," in *Development in Renewable Energy Technology (ICDRET)*, 2012, Dhaka, 2012, pp. 1-5.
- [32] ElectroTechnik. (2012) electrotechnik. [Online]. www.electrotechnik.net
- [33] Arduino. (2000) arduino.cc/en/Tutorial/ArduinoToBreadboard. [Online]. www.arduino.cc
- [34] S. J. Campbell, "Solid State AC Motor Control," pp. 79-189, 1987.
- [35] E. H. Mamdani, "Application of fuzzy algorithm for the control of a dynamic plant," *IEEE Proc.*, vol. 121, pp. 1585-1588, 1974.
- [36] R. Langari, "Past, present and future fuzzy control; a case for application of fuzzy logic in hierarchical control," in *18th Int'l Conf. of the North American Source*, 1999, pp. 760-765.
- [37] Patrick Raymund A. Lesaca, "There is Gold in Tomatoes," *AgriBusiness*, December 2015.
- [38] Santoshkumar and R.Y. Udaykumar, "Development of WSM for Precision Agriculture," *Innovation in Information, Embedded and Communication System*, March 2015.
- [39] Engineeringtoolbox. (2010) Engineeringtoolbox. [Online]. www.engineeringtoolbox.com
- [40] Patrick Lesaca and Raymund A., "There is a Gold in Tomato," *Agri Business*, December 2015.
- [41] Mel Goldstein. (2002, December) www.infoplease.com. [Online]. infoplease.com.