

Dual Axis Solar Tracking System in Perlis, Malaysia

R.S.Zulkafli, A.S.Bawazir, N.A.M.Amin, M.S.M.Hashim, M.S.A.Majid and N.F.M.Nasir
School of Mechatronic Engineering, Universiti Malaysia Perlis, 02600 Arau, Perlis, Malaysia.
nasrulamri.mohdamin@unimap.edu.my

Abstract—Sunlight is an abundant source of energy and this energy can be harnessed successfully using solar photovoltaic panels and convert it into electrical energy. However, the conversion efficiency of a normal PV panel is low. One of the main reasons is the power output of a PV panel is dependent directly on the light intensity. As the position of the sun is changing continuously from time to time, the absorption efficiency of an immobile solar panel would be significantly less at a certain time of the day and year. Therefore, to maximize the energy generation and improve the efficiency, a solar tracker comes into play. This paper presents the design and construction of an inexpensive active dual axis solar tracking system for tracking the movement of the sun to get the maximum power from the solar panels. It uses Light Dependent Resistors (LDR) to sense the position of the sun which is communicated to an Arduino Uno microcontroller. An algorithm is implemented to control DC geared motor's movements which maintaining the solar PV panel position so that it will perpendicularly facing towards the sun at all the effective time. Performance for both fixed and dual-axis solar tracker was compared. Evaluation results show that the dual-axis solar tracking system performs 44.7% better than the fixed solar tracking system.

Index Terms—Arduino Uno Microcontroller; Dual Axis Solar Tracking System; Light Dependent Resistors; Solar Photovoltaic System.

I. INTRODUCTION

It is known that damages on the ozone layer and the high demand for energy have driven mankind to search for a new source that can produce electric energy using renewable technologies and clean, such as wind energy, wave energy, and solar energy. Recently, solar energy is widely used to afford a great possibility for converting into electric power due to its long-term benefits and environmental friendly [1]. It is also able to cover the needs of electrical energy in the earth [2]. Nonetheless, the power generated from PV system does not enough compared to fossil fuels, especially in urban area. Thus, several approaches have been proposed. One of the approaches proposed is solar tracking system [3]. Harvesting energy via tracking system was an initiative method to get an optimum power output from the PV panel compares to fix position solar PV system [4].

II. SOLAR TRACKING SYSTEM

The solar tracking system can be used to maximize the power production since they keep the PV panel perpendicularly to the sun. As the position of the sun is changing continuously from time to time, the PV panel is adjusted by the solar tracking system. There are two classifications of the solar tracking system; active tracker and

passive tracker [5-7].

Active tracking system possesses the sensor feedback determination of the solar position during the day. The sensor will trigger the motor or actuator which will cause a movement of the PV panel, perpendicularly to the sun's position [8]. If the sunlight is not perpendicular to the tracker, then there will be a difference in light intensity on one light sensor compared to another. This difference can be used to determine in which direction the tracker has to be tilted in order to be perpendicular to the sun.

Unlike the active tracking system, the passive tracking system used the idea of thermal expansion of materials. A type of shape memory alloy; typically, a chlorofluorocarbon; is used. When the panel is perpendicular to the sun, both sides of the panel is equilibrium. Sun's movement caused one side of the material is heated and the other side contracts. Thus, resulting the solar panel to rotate [9]. Among these two tracking systems, the active tracking system is reasonably accurate [8]. The rotation panel mechanism has played an important role in order to increase or enhance the efficiency of solar power production [10].

There are two basic mechanisms of rotating panel which are single axis and dual axis [10]. Single axis solar tracker experienced either horizontal or vertical rotating plane. Meanwhile, the dual axis solar tracker has both the horizontal and vertical axes rotating plane and has the capability to track the sun's movement at any places. Among these, the dual axis rotating plane is commonly used as it provides higher accuracy and is well known to improve overall captured solar power by 30-50% compared to the single axis panel [11].

In this paper, an active type dual axis solar tracking system consists of microcontroller, sensors, and actuators were proposed due to greater accuracy compared to passive type solar tracking system [3]. The active solar tracking system is developed based on the dual axis control (according to the azimuth and solar altitude angles) to maximize the solar power generation. To reduce the cost of the system, an Arduino Uno microcontroller board and DC geared motor was used. Four light dependent resistor sensors (LDR) are used to track the sun. To evaluate the effectiveness of the solar tracking system, the dual axis solar tracker and fixed solar tracker efficiency were compared.

III. SOLAR TRACKER SYSTEM COMPONENTS

The main component of the dual axis tracker is Arduino Uno microcontroller. The DC motor movements were controlled by the Arduino which it received an analog signal from the LDR. The DC motor will direct the solar PV panel to the angle which the highest amount of solar energy can be harvested. The block diagram of the dual axis solar tracking

system process is shown as in Figure 1.

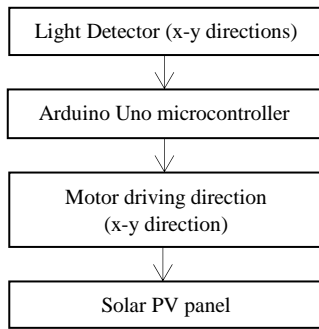

Figure 1: Block diagram of hardware implementation of dual-axis solar tracker

A. Hardware Design

Figure 2 shows the 3D model designed using CATIA software, where body contains three parts to hold and move the solar panel. In general, this design consists of two mechanisms namely movable and fixed joint. The fixed joint is the stand base of the system, while the moving joint has two parts which are placed on the top where the solar panel is connected to it.

The mechanical system is divided into 3 main components namely the inner rectangular frame (Figure3), outer rectangular frame (Figure 4) and the stand (Figure 5). The outer rectangular frame that connected to the stand, also connected to a DC motor which to rotate the solar panel in both East and West directions.

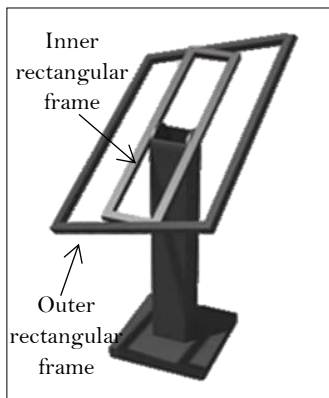

Figure 2: The 3D model of a dual axis solar tracking system

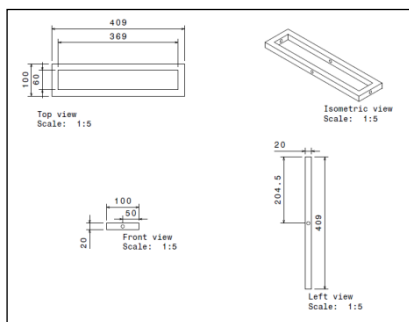

Figure 3: Inner rectangular frame

In Figure 4, the rectangular frame which is the outer frame also holds the solar panel and is connected with a DC motor which allows rotating the solar panel that facing North and South directions.

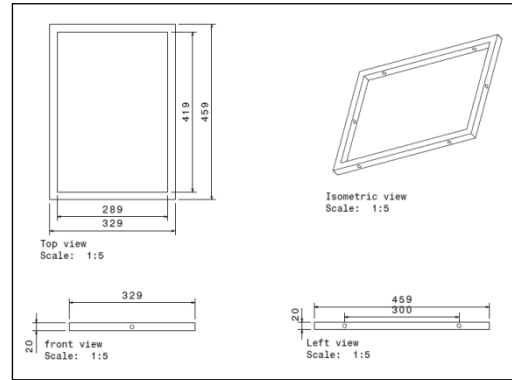

Figure 4: Outer rectangular frame

The stand as in Figure 5 where all the system components connected to is to make the whole system stand stable, and the top of the stand designed to prepare for an easy and smooth movement of both frames.

Most of the joints are mainly a steel material based which can withstand the weight of the solar panel used. The project has been divided into two parts according to their movement where the dual axis need to the different rotation to perform its job in tracking the sun on a regular basis. Two DC geared motors are used to rotate and position the solar panel to always perpendicular to the sun. Figure 6 shows the DC motor in place.

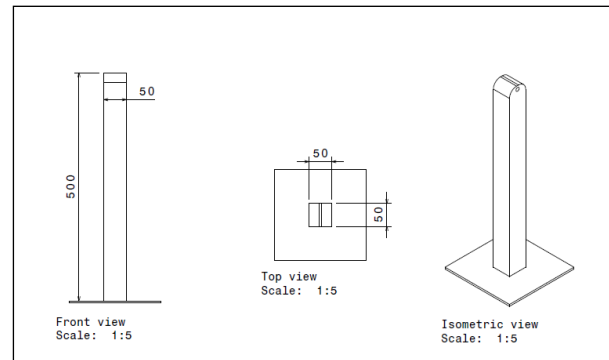

Figure 5: Solar tracker stand

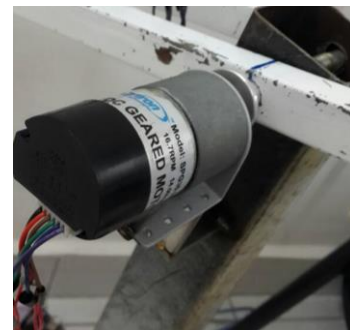

Figure 6: DC motor in place

B. Control System

The sensors used are four LDR sensors to control the motor via them. Each sensor is put on a side of a cross where each value of each sensor will differ according to its position toward the light (as in Figure 7). If the analog output of a sensor is low, the motor will move toward the highest value of the sensors which make the PV panel be in a position perpendicular to the sunlight.

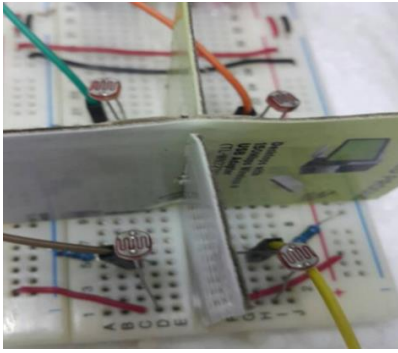

Figure 7: The arrangement of LDR sensors

IV. EXPERIMENTAL SETUP AND RESULTS

A dual axis and fixed axis solar tracker system with horizontal orientation were used in the experiment. The solar tracker has two axes of rotation which enables it to rotate along the west-east and north-south axes. Meanwhile, the fixed solar tracker panel was located at the optimum tilt angle for the location of Perlis which is 6.840° [12].

The testing is to observe the differential power output for both fixed and dual axis solar tracking system in real field conditions. The results indicate the efficiency and performance of the trackers during a sunny day. The testing has started at 8.00 a.m. until 6.00 p.m. The data are recorded for every one hour.

The rotation of dual axis solar tracker panel is as shown in (Figure 8). This movement is controlled by DC motors, where the angle of this axis is controlled via microcontroller depending on the values read from the sensors used.

From the data collected, the higher average output power with a tracking system is 31.293W and without tracking is 29.667W. The results for the different operating PV systems can be seen in Table 1.



Figure 8: Dual axis rotations

Table 1
Daily power yield of the fixed and dual-axis solar tracking system

Hour	Fixed (W)	Dual-axis (W)
0800	1.126	3.066
0900	14.104	21.703
1000	17.672	24.897
1100	23.305	30.008
1200	29.667	31.293
1300	23.895	29.430
1400	20.349	28.768
1500	16.556	25.477
1600	11.124	21.930
1700	6.6255	15.302
1800	2.066	9.211

The daily power output of PV systems for the representative clear day was presented in Figure 9. The systems reached their maximum power at 12.00 p.m. From the data collected, harvested sunlight via dual-axis tracking system is 44.7% higher than the fixed solar tracking system. This is due to the tracking system efficiency that can capture the sunlight by tracking the sun movement.

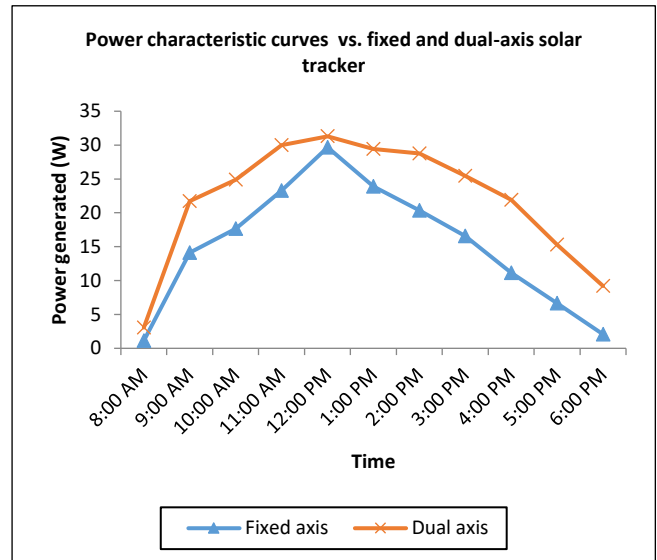

Figure 9: Solar tracking systems power generated

V. CONCLUSION

A dual axis sun tracking system for a PV system is briefly described and the performances for both dual axis and fixed tracking systems are summarized. The power yield is 166.5W for fixed solar tracker and 241W for the dual axis solar tracker. It is calculated that 44.7% more power obtained in the dual axis sun tracking system when compared to the fixed solar tracking system.

ACKNOWLEDGMENT

The authors would like to acknowledge the Ministry of Higher Education of Malaysia and the Universiti Malaysia Perlis, Perlis, Malaysia, for the financial support under FRGS (9003-00564).

REFERENCES

- [1] S. Ahmad, S. Shafie and M. Ab Kadir, "Power Feasibility of a Low Power Consumption Solar Tracker", *Procedia Environmental Sciences*, vol. 17, pp. 494-502, 2013.
- [2] T. Tudorache and L. Kreindler, "Design Of A Solar Tracker System For Pv Power Plants", Vol. 7, No. 1, Pp. 23-39, 2010.
- [3] J. F. Lee and N. A. Rahim, "Performance comparison of dual-axis solar tracker vs static solar system in Malaysia," in *2013 IEEE Conf. Clean Energy Technol.*, pp. 102-107, Nov. 2013.
- [4] N. Afifah, N. Syafawati, S. Idris, A. Haziah and M. Syahril, "Development of Dual Axis Solar Tracking System Performance at Ulu Pauh, Perlis", *Applied Mechanics and Materials*, vol. 793, pp. 328-332, 2015.
- [5] S. Ozelcik, H. Prakash, and R. Chaloo, "Two- Axis Solar Tracker Analysis and Control for Maximum Power Generation," *Computer Science*, Vol. 6, pp. 457-462, 2011.
- [6] M. Zolkapli, S. Al-Junid, Z. Othman, and M. Mohd Zulkifli, "High Efficiency Dual-Axis Solar Tracking Development using Arduino," in *2013 International Conference on Technology, Informatics, Management, Engineering & Environment (TIME-E 2013)*, Indonesia, June 23-26, 2013.

- [7] H. Mousazadeh, A. Kehyani, A. Javadi, H. Mobli, K. Abrinia and A. Sharifi, "A Review of Principle and Sun Tracking Methods for Maximizing Solar System's Output," *Renewable and Sustainable Energy Reviews*, 2009.
- [8] R. Vieira, F. Guerra, M. Vale and M. Araújo, "Comparative performance analysis between static solar panels and single-axis tracking system on a hot climate region near to the equator", *Renewable and Sustainable Energy Reviews*, vol. 64, pp. 672-681, 2016.
- [9] T. Kaur, S. Mahajan, S. Verma, Priyanka and J. Gambhir, "Arduino based low cost active dual axis solar tracker", *2016 IEEE 1st International Conference on Power Electronics, Intelligent Control and Energy Systems (ICPEICES)*, 2016.
- [10] F. Abdullah, M. Munaaim, S. Basah and S. Yaacob, "The feasibility study of applying solar tracking in power plant Kuala Perlis, Malaysia", *2016 IEEE Conference on Systems, Process and Control (ICSPC)*, 2016.
- [11] N. Kelly and T. Gibson, "Improved photovoltaic energy output for cloudy conditions with a solar tracking system", *Solar Energy*, vol. 83, no. 11, pp. 2092-2102, 2009.
- [12] I. Daut, M. Misrun, E. M and M. Yusoff, "Performance of Photovoltaic Module at Different Tilt Angles in Perlis, Northern Malaysia", *International Review on Modelling and Simulations*, vol. 3, no. 6, pp. 1335-1343, 2010.