

Design and Implementation of a Voltage Tracking with Artificial Neural Network Controller for a Double-input Buck-Boost Converter

Yonis. M. Buswig¹, Al-Khalid bin Hj Othman¹, Norhuzaimin bin Julai^{1,2} and Sim Sy Yi²

¹Department of Electrical and Electronic Engineering, Faculty of Engineering, Universiti Malaysia Sarawak, 94300, Kota Samarahan.

²Department of Electrical Engineering Technology, Faculty of Engineering Technology, Universiti Tun Hussien Onn, 86400 Parit Raja, Batu Pahat, Johor, Malaysia.

byonis@unimas.my

Abstract—This paper proposes an Artificial Neural Network (ANN) control voltage tracking scheme of a double-input buck-boost DC-DC converter. In this topology, a back-propagation algorithm topology is implemented. The controller is developed to improve the performance of the double-input converter during transient and steady-state operations. The neural network controller design, which is developed against output voltage command tracking is proposed. The proposed concept has been investigated and validated experimentally on a laboratory prototype using DSP TMS320F28335 real time digital controller to verify the dynamic response of the proposed controller. The experimental results confirm the validity of the proposed neural network control technique, which is a promising an efficient control topology that ensures double-input converter suitable for electric vehicle and renewable energy applications.

Index Terms— Artificial Neural Network Controller; Double-Input Buck-Boost Converter; Voltage Tracking.

I. INTRODUCTION

These days, double-input direct current (DC) power supplies are extensively used in many applications comparisons to single input power electronic devices such as electric vehicle and the green energy applications [1].

Consequently, the DC-DC double-input converter is used by converting a DC voltage which generated from different input voltage sources to a different DC voltage level to provide the DC output voltage level requirements of the load [12]. Additionally, the DC-DC double-input converter is also a substantial application for the power conditioning of the alternative electrical energy such as photovoltaic, wind generator and fuel cell system. For these reasons, the DC-DC double-input converter applications will lead to a more possibility potential market in green energy applications [2].

Essentially, the double-input converter consists of the power semiconductor devices which are operated as electronic switches circuits to convert the electrical energy from different electrical energy supplies. Implementation of the power switching devices causes the inherently nonlinear characteristic of the double-input converters. Due to this unfavorable nonlinear characteristic, the double-input converters require a control unit with a high performance of dynamic response [3].

To solve this problem and develop the dynamic response of double-input converters, various intelligent control

techniques such as fuzzy logic and neural network methods for double-input converters have been reported in [4]- [11].

A. Double-Input Buck-Boost Converter

The circuit outline of the proposed double-input buck-boost converter as shown in Figure 1. It had been intentionally assumed that switch 1, switch 2, switch 3 and switch 4 indicated as S1, S2, S3 and S4 respectively while diode 1, diode 2, diode 3 and diode 4 indicated as D1, D2, D3 and D4 respectively. A circuit outline of the proposed double-input buck-boost DC-DC converter is depicted in Figure 1.

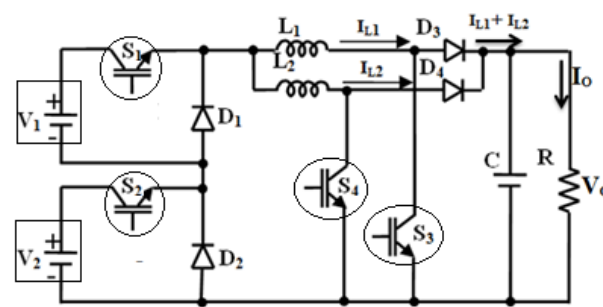

Figure 1: Circuit outline of the double-input buck-boost DC-DC Converter.

B. Voltage Transfer Ratio of The Proposed Double-input Buck-Boost Converter

Switching pattern of switches S1, S2, S3 and S4 are shown in Figure 2. The pattern is valid for all the possible arrangements of the proposed converter as it is composed of all the four operation modes.

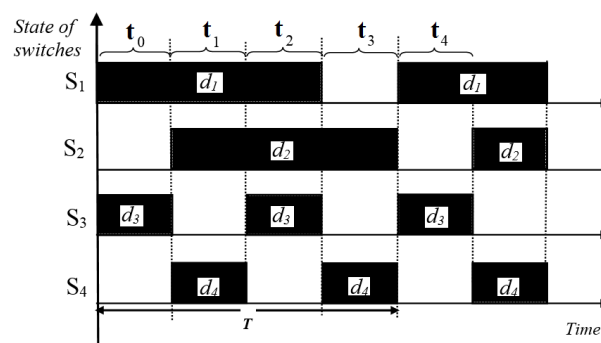

Figure 2: Switching pattern signals and duty cycle of switches.

T is the time period of the switching signal patterns of S₁, S₂, S₃ and S₄ of switches respectively. One can write the following equations for a multi-input interleaved buck-boost converter based on Figure 2 and volt-second balance equation of the inductors.

$$t_0 + t_1 + t_2 + t_3 = T \quad (1)$$

Assume that the current had reached a steady state. Therefore, by analyzing can be obtained:

$$V_1(d_1 - d_{3,4})T + (V_1 + V_2)d_{3,4}T - V_o(1 - d_1)T + V_2(d_2 - d_{3,4}) - V_o(1 - d_2) = 0 \quad (2)$$

Equation (2) in principle can be solved to find voltage output transfer ratio V_o. After several algebraic manipulations and solving, the expression for the output voltage shown as the following Equation (3) [1].

$$V_o = \frac{V_1 d_1}{1 - d_{3,4}} + \frac{V_2 d_2}{1 - d_{3,4}} \quad (3)$$

C. The Proposed Structure of Artificial Neural Network Control

The network of the proposed neural network controller architecture has a 1-4-1 neurons structure. The structure of the proposed neural network controller of a double-input converter as shown in Figure 3.

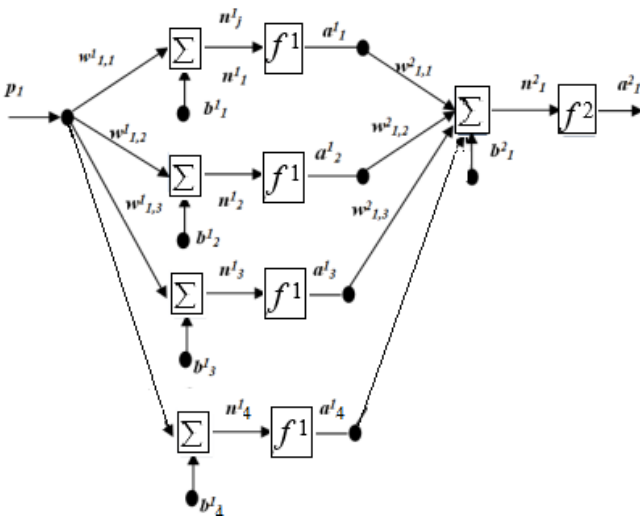

Figure 3: Architecture of the proposed neural network control

The connections weight parameter between *j*_{th} and *i*_{th} neuron at *m*_{th} layer is given by *w*_{*ij*}, while bias parameter of this layer at *i*_{th} neuron is given by *b*_{*mi*}. The transfer function of the network of *the* neuron in *m*_{th} layer is defined as:

$$n_i^m = \sum_{j=1}^{S^{m-1}} w_{ij}^m a_j^{m-1} + b_i^m \quad (4)$$

The output function of neuron at *m*th layer is given by:

$$a_i^m = f^m(n_i^m) \quad (5)$$

where *f* is activation function of the neuron. In this design, the activation function for the output layer and the hidden layer are unity and a tangent hyperbolic function respectively. The activation function of the hidden layer is given as:

$$f^m(n_i^m) = \frac{2}{1 + e^{-2n_i^m}} - 1 \quad (6)$$

Updating of the connection weight and bias parameters are given by:

$$w_{ij}^m(k+1) = w_{ij}^m(k) - \alpha \frac{\partial F(k)}{\partial w_{ij}^m} \quad (7)$$

$$b_i^m(k+1) = b_i^m(k) - \alpha \frac{\partial F(k)}{\partial b_i^m} \quad (8)$$

where *k* is sampling time, *α* is learning rate, and *F* performance index function of the network.

II. LEARNING ALGORITHM OF BACK PROPAGATION TOPOLOGY

After the neural network architecture is modeled, the next stage defines the learning model to update network parameters. By this learning capability, it makes the ANN suitable to be implemented for the system with the proposed double-input buck-boost converter parameters. The training process minimizes the error output of the network through an optimization method. Generally, in learning mode of the neural network controller a sufficient training data input-output mapping data of a plant is required. The online learning back propagation algorithm is designed and developed. The performance index is the sum of square error as a function of sampling time and is given by:

$$F(k) = \frac{1}{2} \sum_i e_i^2(k) \quad (9)$$

$$e_i(k) = t_i(k) - a_i(k) \quad (10)$$

where *t_i* is target signal and *a_i* output signal on the last layer.

The gradient descent of the performance index against to the connection weight is given by:

$$\frac{\partial F}{\partial w_{ij}^m} = \frac{\partial F}{\partial n_i^m} \frac{\partial n_i^m}{\partial w_{ij}^m} \quad (11)$$

The sensitivity parameter of the network is defined as:

$$s_i^m = \frac{\partial F}{\partial n_i^m} \quad (12)$$

$$s_i^m = \frac{\partial F}{\partial a_i^m} \frac{\partial a_i^m}{\partial n_i^m} \quad (13)$$

Gradient the transfer function again to the connection weight parameter is given by:

$$\frac{\partial n_i^m}{\partial w_{ij}^m} = a_i^{m-1} \quad (14)$$

By substituting Equation (12) and (14) into Equation (7) the updating connection parameter is given by:

$$w_{ij}^{m-1}(k+1) = w_{ij}^{m-i}(k) - \alpha s_i^m(k) a_i^{m-1}(k) \quad (15)$$

With the same technique, the updating bias parameter is given by:

$$b_i^{m-1}(k+1) = b_i^{m-i}(k) - \alpha s_i^m(k) \quad (16)$$

III. EXPERIMENTAL RESULTS

The proposed concept has been investigated and validated experimentally on a laboratory prototype using DSP TMS320F28335 real-time digital controller to verify the dynamic response of the double-input buck-boost converter with proposed neural network control. Block diagram of the proposed neural network control unit is shown in Figure 4. The double-input buck-boost converter parameters are shown in Table 1.

A fixed switching frequency and pulse width modulation (PWM) switching technique of switching signals have been chosen for experimental results study. The prototype of the proposed double-input buck-boost converter with using DSP

TMS320F28335 real time digital controller shown in Figure 5.

In case verifying of output voltage tracking capability for the proposed double-input buck-boost converter, the experimental results showed that the proposed controller has the ability to tracking the voltage reference variations in case of stepping-up and stepping- down and displays a very low-rise time and negligible overshoot.

It is found that the output voltage startup transient response of the double-input buck-boost converter with reference voltage lower than two input voltage sources (V1 and V2) as in the case of the buck converter (the output voltage 55 V) and higher than the two input voltage sources (V1 and V2) as in the case of the boost converter (the output voltage at 70 V) and as shown in Figure 6 and Figure 7 respectively.

Table 1
Parameters of the double-input converter

Variable	Parameter	Value
L_1 & L_2	Inductance	0.5 mH
C	Capacitance	480 μ F
R	Resistor	100 Ω
V_1	First input voltage	24 V
V_2	Second input voltage	36 V
S_1 & S_2	Switching frequency	10 kHz
S_3 & S_4	Switching frequency	20 kHz
d_1 & d_2	Duty cycle for main switches	75%
d_3 & d_4	Duty cycle for interleaved switches	50%
V_o	Output voltage	55 V - 70 V

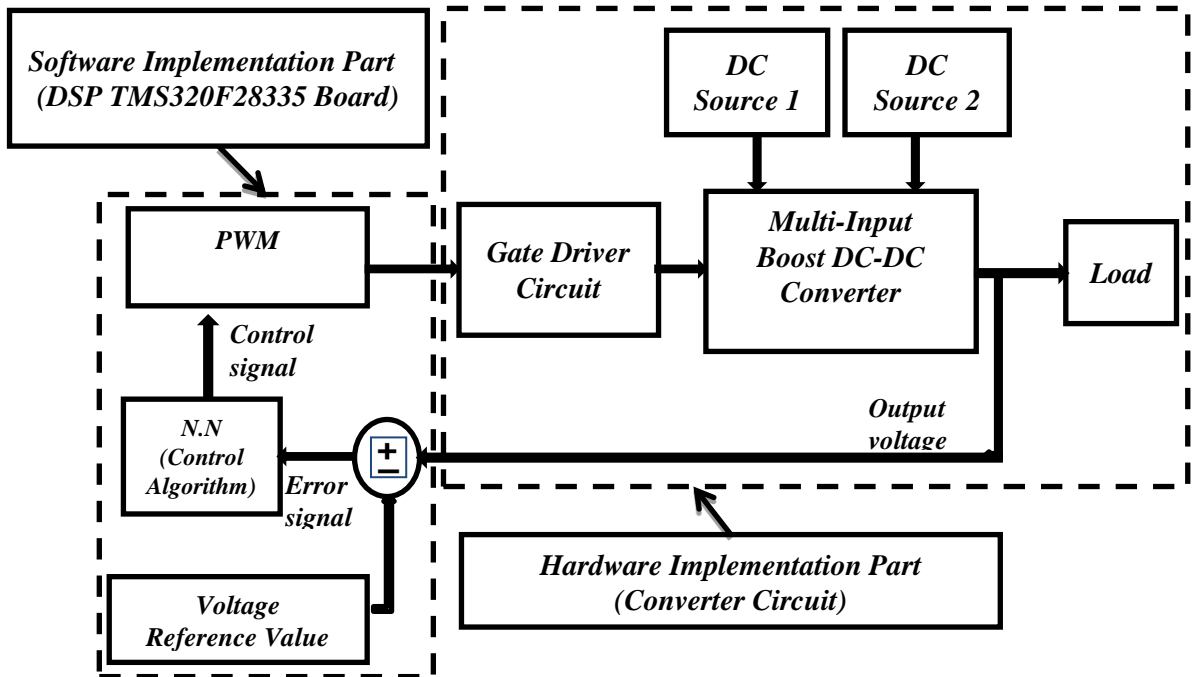

Figure 4: Schematic diagram of the proposed neural network control

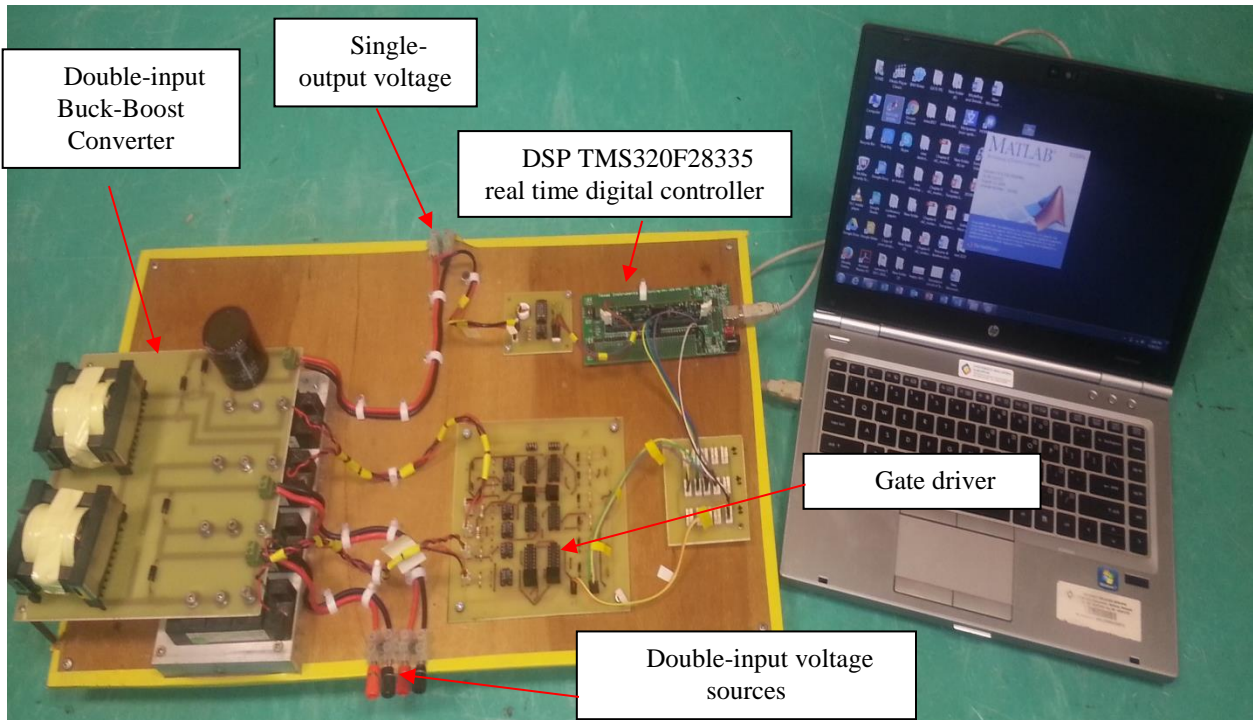

Figure 5: The experimental set-up of the proposed double-input converter

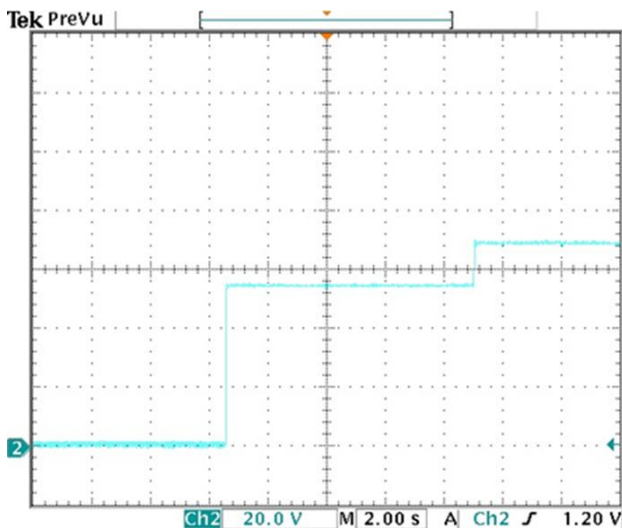

Figure 6: The dynamic response of the double-input converter when the output voltage is commanded to step-up from 0V to 55V to 70V.

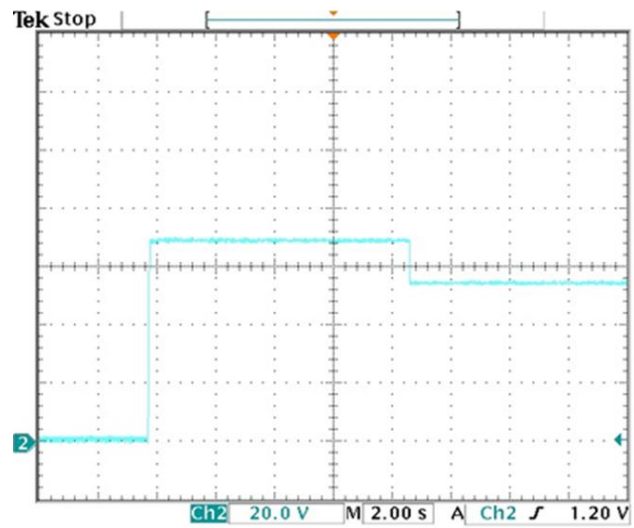

Figure 7: The dynamic response of the double-input converter when the output voltage is commanded to step-down from 70V to 55V.

IV. CONCLUSION

In this paper, a neural network control for double-input buck-boost DC-DC converter is discussed. To enhance and improve the performance of the voltage tracking of a double-input converter, a back-propagation topology is developed. It is observable that the neural network control unit is effective in decreasing overshoot, reducing settling time and has a fast response to track desired output voltage. In addition, based on the experimental results, the implementation of the back-propagation technique is a feasible solution for the output power regulation for double-input converters supplied with different input voltage sources such as solar panel and wind turbine in renewable energy system applications.

ACKNOWLEDGMENTS

The authors would like to gratitude research and innovation management center (RIMC) UNIMAS for valuable supports during conducting this research which funded by a Special Short Term Grant (SpSTG), University Malaysia Sarawak. Grant number: F02/SpSTG/1582/2017.

REFERENCES

- [1] Y. M. Buswig, W. M. Utomo, and Z. A. Haron, "Power sharing analysis of a new modified multi-input interleaved boost converter based on h-bridge cells," *ARNP Journal of Engineering and Applied Sciences*, pp.3943-3950, 2016.
- [2] Y. M. Buswig, W. M. Utomo, Z. A. Haron, and S. S. Yi, "Multi-Input Boost Converter for Hybrid PV and Wind Generator Systems," In *Advanced Materials Research*, pp.619-624, 2014.
- [3] W. M. Utomo, S. S. Yi, and M. Y. Yonis, "Voltage Tracking of a DC-

- DC Flyback Converter Using Neural Network Control,” *International Journal of Power Electronics and Drive Systems*, vol. 2, no. 1, p. 35 2012.
- [4] K.-H. Cheng, “Fuzzy–Neural Sliding-Mode Control for DC–DC Converters Using Asymmetric Gaussian Membership Functions,” *IEEE Transaction on Industrial Electronics*, pp. 1528- 1536, 2007.
- [5] C.-F. Hsu, “Intelligent Control for DC-DC Power Converter with Recurrent Fuzzy Neural Network Approach,” *IEEE International Conference*, pp.16-21, 2006.
- [6] G. G. Oggier, G. O. Garcia, and A. R. Oliva, “Modulation strategy to operate the dual active bridge DC-DC converter under soft switching in the whole operating range,” *IEEE Trans. Power Electron.*, vol. 26, pp. 1228–1236, 2011.
- [7] T. Gupta, “Implementation of a fuzzy controller for DC-DC converters using an inexpensive 8-b microcontroller”, *IEEE Transaction on Industrial Electronics*, pp. 661-669, 1997.
- [8] J. Mahdavi, “Application of neural networks and State -space averaging to DC/DC PWM converters in sliding-mode operation,” *IEEE Transaction on Mechatronics*, pp. 60 – 67, 2005.
- [9] W. M. Utomo, “Online Learning Neural Network Control of Buck - Boost Converter,” *Eighth International Conference on Information Technology: New Generations*, pp. 485–489, 2011.
- [10] R. Leyva, “Identification and control of power converters by means of neural networks,” *IEEE Transaction on Industrial Applications*, pp.735-742, 1997.
- [11] W. M. Utomo, “Voltage Tracking of a DC-DC Buck-Boost. Converter Using Neural Network Control,” *IEEE International Journal of Computer Technology and Electronics*, pp.108-113, 2011.
- [12] X. T. Guo, J. C. Jiang, L. Y. Niu, J. X. Li, Y. Q. Qu, “A 10kW DC-DC system based on a bidirectional high-frequency isolated dual active bridge DC-DC topology,” In *Proceedings of IEEE Power Engineering and Automation Conference*, Wuhan, China, pp. 50–54, 8–9 Sep. 2011.