

# Intelligent Approach of Event Detection with Efficient Energy Consumption in Wireless Sensor Networks

M. A. El abbassi, A. Jilbab, A. Bourouhou

*Electrical Engineering Research Laboratory  
ENSET-Rabat, Mohammed V University in Rabat, Morocco  
Elabbassi.3@gmail.com*

**Abstract--** In the context of environmental protection against fire, this work presents a hybrid system of decision making and early warning applied in wireless sensor networks. This system, also, integrates an efficient data routing technique, based on the clustering of the near-event nodes, ensuring judicious network energy consumption. Data fusion technique, based on sensors data aggregated by the Cluster Head node (CH) within a defined analysis area, is processed by K-medoids, the latter will mainly contribute to increase the system's performances by decreasing the intra-cluster noise parameter ( $\sigma$ ) conducting to improve the probability of detection. This step, therefore, will distinguish and merge only the correct and useful samples. On the basis of the fused data, the estimated alert by K-Nearest Neighbours (KNN) can be directly triggered based on a minimum number of sensor nodes detecting fire; this will affect in advantage on the rapidity of detection, which leads to limit the spread of fire quickly. The alert is transmitted from the CH node to the base station via an intermediate node (IN) elected intelligently outside the cluster. This proposed approach proves, through its simulation results, a remarkable improvement of system performances in terms of information reliability, rapidity of detection and alert, avoiding false and redundant information, and also it improves extending the network lifetime.

**Index Terms---** Data fusion; Decision-making; K-medoids; K-Nearest Neighbors; Network lifetime; Wireless Sensors Networks.

## I. INTRODUCTION

Wireless sensor networks (WSN) [1] remain, until now, among the prestigious technologies attracting more and more attention in various applications, such as the environmental monitoring, where the use of this technology can avoid the damage of one of the most natural disasters: the forest fire [2]. In such application, node sensors deployed in the forest area are able to measure, process and communicate their environmental data quickly in an autonomous manner with the base station [3, 4, 5]. However, these physical parameters collected cannot directly reflect the actual physical state of the coverage area. The autonomous estimate of each sensor tends to increase the probability of false alarm, as some sensors may be in a failure condition or far from the event, and deliver incorrect or imprecise information, which will directly affect the detection reliability. In order to improve the reliability of the estimation and to help reduce transmission energy consumption, the samples derived from these nodes must be

collected and processed in the data fusion centers [6] (as in the node master), this data fusion operation [7] is able to ensure a good reliability of information with a minimum of redundant information. (Figure1).

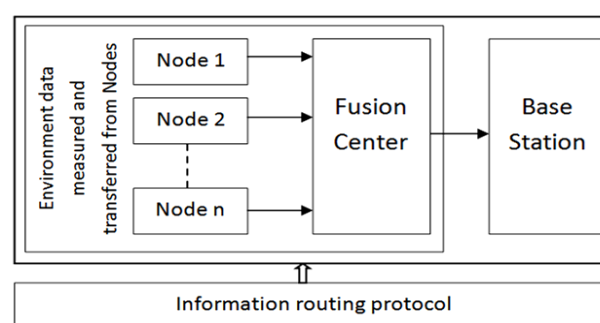

Figure1: Data fusion architecture

On the other hand, it is strongly recommended to apply an information routing protocol, which will therefore increasingly contribute to extend the life of the network while maintaining the highest network energy level for the possible maximum duration. Since each of these nodes sensors constituting the network has a limited power source (battery), which is consumed more by the wireless communication module, taking into consideration that the data transmission energy in k bit is more important than that of receiving data in k bit that is based on the energy model of the first order radio adopted in [8]. Such energy consumed in transmission also depends on the distance separating the transmitting node from the receiving node. As a result, it will be a quick loss of energy resources if there are sensors deployed in an environmental zone that measure and send their data directly to the base station.

In this work, we plan to improve the performance of the WSN system by proposing a robust approach that combines heterogeneous multi-sensor data fusion with information routing based on the concept of clustering conditioned by the appearance of the event. Such a model is applied in the context of the environment protection against fires. The work is organized as follows: Introduction describing, in general, the problem that leads to the development of the research paper. Section II outlines briefly some approaches recently developed in the same context. Section III discusses the methodology of the proposed global approach including the proposed method of heterogeneous data fusion, Section IV presents a set of results of the simulation with evaluation

of the performances of the proposed model, and the last section presents a general conclusion of this work.

## II. RELATED WORKS

Many research works have been developed on event detection systems applied on WSN, one of the most crucial factors to improve detection performance is the processing of data fusion on which several algorithms and models have been proposed.

Khanna & Cheema. [13] presented a data fusion method exploiting the fuzzy logic algorithm type II, in order to estimate the probability and the direction of the detected fire. Each node deployed in nature can capture several physical parameters. These nodes can form several clusters where every cluster has its own CH. The data measured by these sensor nodes will be transferred to their Cluster Head. In the same context, Arikumare et al. [10] proposed a data fusion mechanism for fire detection aiming at reducing the redundant data by reducing the transmission of the packets generated by the sensors transferred to the Cluster Head (CH) and finally forwarded to the Base Station (BS). This mechanism allows establishing beforehand the first two levels of Fuzzy Inference System (FIS) within the sensor node, then to logically reason through its resulting confidence factor with the aim to decide whether to transfer the data or not to CH where the third level of FIS will be performed. Sekkas et al. [14] presented another sophisticated model for early detection of fire. This model is based on a multi-level heterogeneous data fusion. The first level evaluates the statistical behavior of sensor data of temperature, humidity and also of vision (camera) type; whereas, the second level was adopted to combine all the outputs data of the primary level by exploiting the Dempster-Shafer theory.

Several other research activities discussing event detection models applied in WSN, ensuring, also, a good energy consumption management of the network; Izadi et al., presented in [9] a data fusion approach in the WSN based on fuzzy logic. This approach results in improving the system performances of the network by ignoring the redundant data from sensors while collecting only the correct and useful data for data fusion. On the other hand, it also allows reducing its energy consumption in comparison with other approaches. Das et al. [11] proposed a technique of energy-aware routing based on the fusion of multi-sensor data using the Bayes algorithm and the Ant Colony Optimization method (ACO). The results of simulation of the method show the good residual energy of the network compared to the protocol of LEACH (Low-Energy Adaptive Clustering Hierarchy) [8]. Another mechanism adopted by Zhang et al. [12] in the context of improving the performance of WSN in terms of energy consumption and the reliability of fused data. This technique is based on a concept of aggregation of measured data driven by time composed by a sensor node scheduling technique and combined with a batch estimation method that is based on data fusion using the Kalman filter algorithm. Our proposed

system follows in the same context these works category; it allows to deploy a good event detection service based on a multi-sensor data fusion elaborated within the CH node, the proposed method of data fusion and decision-making is based on K-medoids algorithm chained to KNN classifier. This global mechanism integrates, also, an intelligent information routing technique with the relation to event detection, capable to intelligently and partially exploit the network in relation to the appearance of the fire, ensuring very good management of energy consumption of the network which contributes to maximizing its lifetime.

## III. PROPOSED APPROACH

The proposed model presents an intelligent system elaborated for a reliable decision-making and early alerting with the wiser exploitation of network nodes in order to enhance the lifetime of the WSN's system. A general architecture is given in Figure 2.

This system is based, at the entrance, on sensor nodes that measure three types of different physical quantities: temperature, humidity, and smoke types (considering other types of sensors). In the case of a first alert translating the start of the fire detected by the nearest node, this latter forms an analysis segment with  $N$  nearest neighboring sensors. It is considered as a cluster constituted by Cluster Members (CM) (sensor nodes) and their own Master named Cluster Head (CH). Thereafter, the sensor having the highest residual energy in this cluster will be directly elected as CH of the group. The other sensor nodes belonging to the cluster are then dedicated to collect the environmental information and then to the process and send these data to the CH. The latter aggregates all these data and leads off a data sorting and merging processing. The resulting fused information is directly classified to affirm or to deny the presence and the propagation of the event. In the affirmative case, the CH node transfers the fire propagation alert message to the Intermediate Sensor node (IN), located outside the analysis cluster. The IN node is also elected for each new sequence and plays the role of the bridge connecting between the CH node and the Base Station (BS). This intermediate node is engaged if there is a situation of alert. The election of IN node is based on its residual energy which must be higher among others and on its distances to Sink and to CH node, which must be lower than the threshold distance denoted  $d_{th}$ . In the case of an alert message received by IN node, the latter finally transfers this information to the Base Station. Thus, it declares the end of a cycle, in order to start a new one again.

All these nodes deployed in the global zone, including the nodes located outside the cluster, are scheduled to switch between the sleep state for a  $T_s$  period and the waking up state for a  $T_w$  period ( $T_s > T_w$ ) in order to optimize energy consumption while periodically offering their services.

If, subsequently, one or more other sensors located outside the cluster detect the fire, the same global processing will occur and help to trace and monitor the fire propagation path.

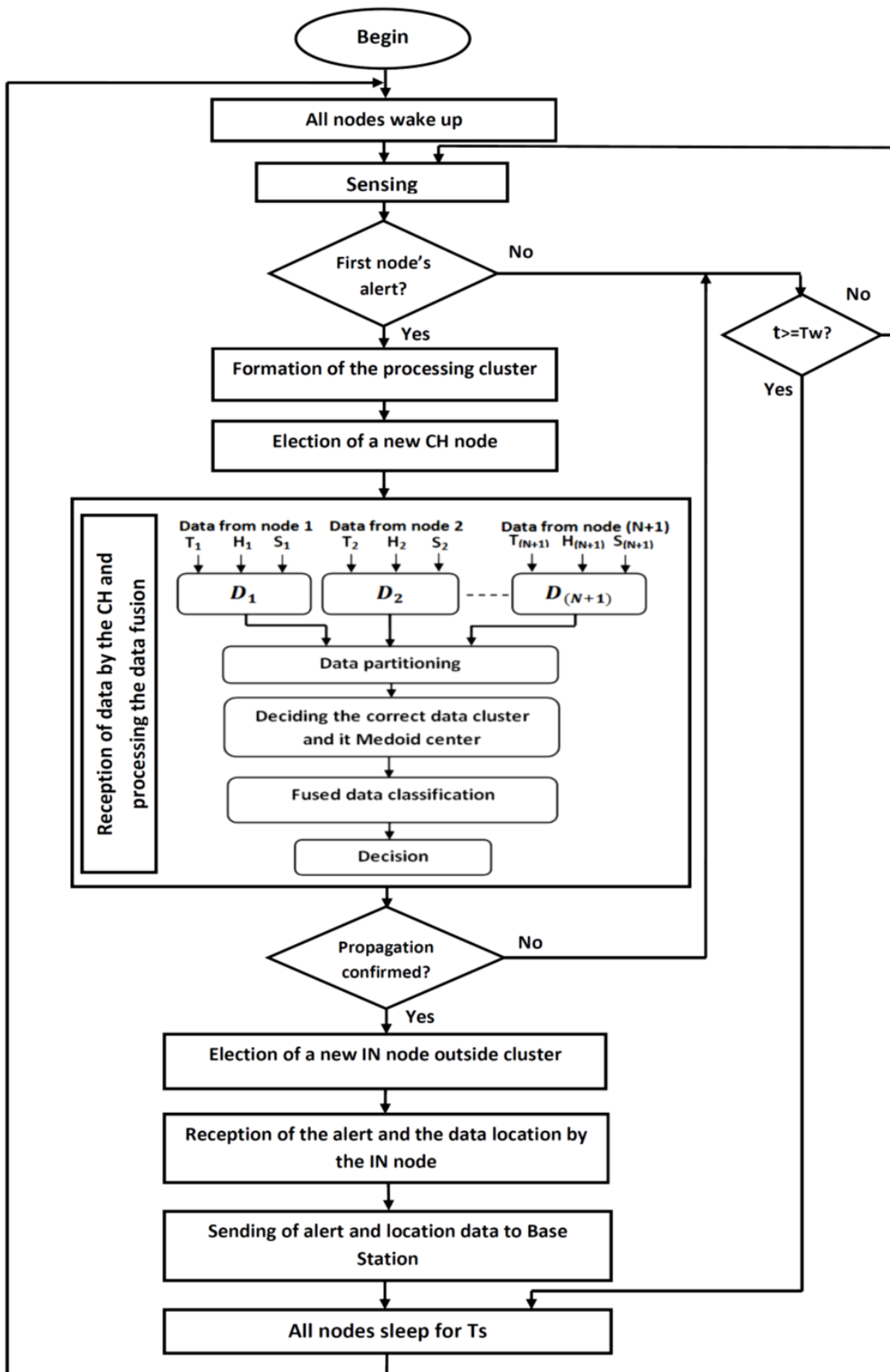

Figure2: The proposed system flowchart

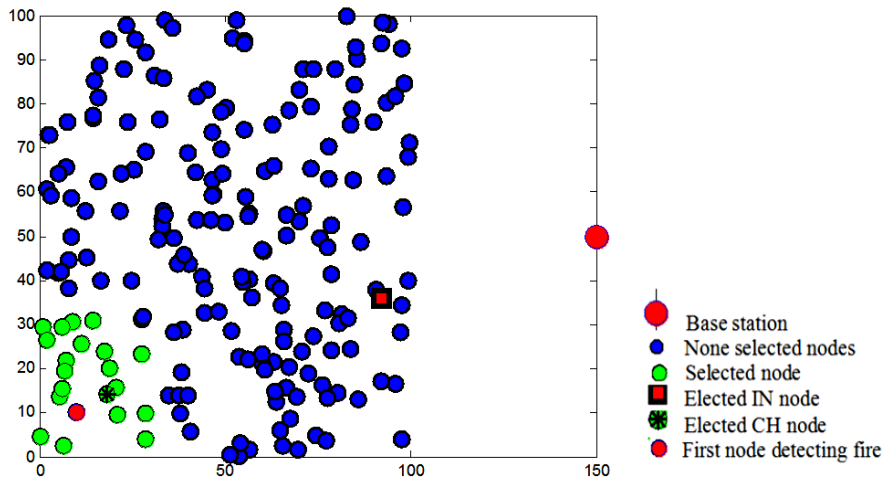

Figure3: Sensors network architecture exploited by the proposed system

The proposed approach is conditioned by the occurrence of the event exploiting, in the case of fire, a limited number of sensor nodes (as shown in Figure3), and thus minimizing unnecessary communication sensors that are far from the event location and reduce their transmissions packets. This also helps to maximize the lifetime of the network in comparison with LEACH (Low-Energy Adaptive Clustering Hierarchy) [8] and M-GEAR (Gateway-Based Energy-Aware Multi-Hop Routing Protocol) [15], that exploit, in their processing, the total platform of the network.

A. Data Fusion Technique

This part describes the proposed fusion method, which aims at estimating the physical state of the analysis zone monitored by  $N$  members that belong to the cluster (plus their CH). This estimation makes the possibility to affirm or deny the presence and the propagation of fire. And, as already mentioned above, this operation is performed within the elected CH node.

So, this data fusion technique consists of hierarchical levels of processing (see Figure2) starting with the collection of measurements series of the three physical quantities (temperature, humidity, and smoke) delivered from these  $(N+1)$  nodes, where each three different measured quantities constitute at  $t'$  instant, the coordinates of a single collected data. Thereafter, a data partitioning pretreatment is performed for the purpose of extracting the correct samples using the K-medoids clustering [16, 17]. The calculated medoid center is a final representative object of the cluster, which is considered, in this treatment, as a three-dimensional fused data, which will be processed and classified later by the KNN classifier [18, 19] in order to make the final estimation of the state of this located zone.

1) First Level Process: Sorting Information and Extracting the Fused Data

This part aims to exploit the K-medoids clustering [16, 17] for the purpose to eliminate data obtained from defective or imprecise sensors and extract the representative items that belong to the subset of the sorted correct data. And to briefly define K-medoids, this latter is a classical data partitioning technique whose objective is to group all data of  $n$  objects in  $k$  clusters by minimizing the sum of the distances between these samples and the item designated as a center of the cluster (medoid), which is a member belonging to this subset.

Among the main reasons for using the K-medoids technique in this application of data fusion; is that this partitioning algorithm, in comparison with other algorithms such as K-means [23], is capable of handling the noisy data, the outliers or the erroneous values effectively. Thus, this applied technique has good immunity for these extreme value samples that are derived from the erroneous sensors or those located far from the event; this eventually leads to extract the final medoid representing the cluster efficiently.

Let  $N$  selected nodes in the analysis cluster (see Figure1) (plus their CH node), where each node provides at every  $t=\tau$ , a tridimensional sample denoted  $D(H,T,S)$ . These data (humidity, temperature and smoke samples) are aggregated in CH node, where data sorting and fusing operations, are carried out by employing the K-medoids algorithm [16]. The number  $K$  of clusters can reach at most: 4. This choice is reasoned, since the collected raw data can belong to one of the four categories; the cluster of None-Fire correct data, the cluster of Fire correct data, the cluster containing Lower incorrect data and the cluster of Upper incorrect data. These clusters results are illustrated in a 3D projection along three axes: Humidity, Temperature and Smoke, as shown in Figure4 (An example of a single series of measurements).

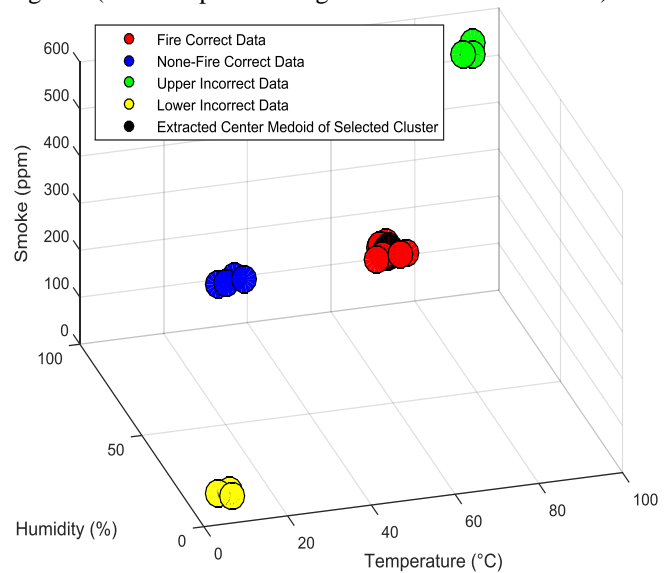

Figure4: Clustering data and extracting the medoid center of the selected subset (A 3D simulation over twenty one nodes of which six are failing, five are still far from the fire and ten are supposed in the fire zone.K=4)

After partitioning all collected data in  $K$  clusters, it remains to distinguish the subset of the relevant and the correct information. This reasoning takes into consideration both conditions:

- In the normal case, it is the cluster with a predominance of data among others.
- In the case of fire: it is the fire cluster having at least  $C_{min}=5$  collected data.

The center (medoid) of the sorted data represents the fused data denoted  $FD$  (as shown in Figure4).

## 2) Second Level Process: Data Classification and Decision-Making

This part focuses on the application of K-Nearest-Neighbors algorithm (KNN) [18, 19] for making an estimation output based on the medoid data input as denoted  $FD$ . It is noted that this classifier is among the most known techniques for classification of the objects, which has been applied since 1970's.

Given that  $FD(H_{mb}, T_{mb}, S_{md})$  represents a tridimensional combined sample based on the three physical quantities, where each  $FD$  result must be processed and assigned to one of two clusters. Note that the first cluster describes the hypothesis of 'None-Fire' while the second represents the hypothesis of 'Fire', as illustrated in Figure5.

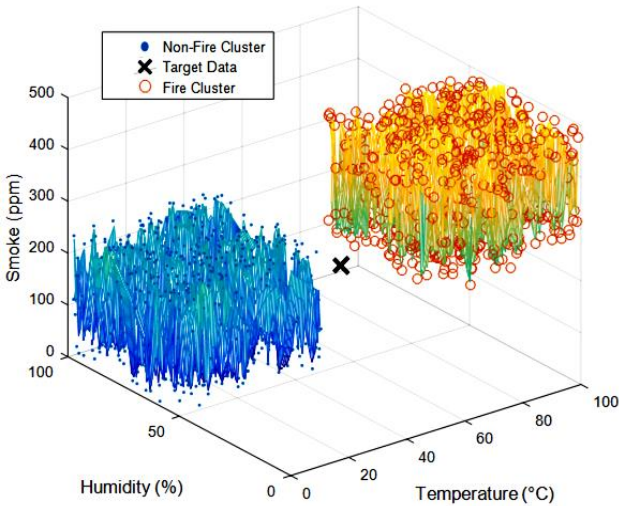

Figure5: An example of 3D projection of an  $FD$  target with two learning database clusters

These clusters are considered as sets of learning data on which the KNN refers to decide the output. These fixed intervals thresholds in the relation of temperature, humidity, and smoke, are based on real experiments about the generation of the fire event under different conditions. The adjustments of these intervals can also depend on the climatic nature of the monitored area.

The classification process of the  $FD$  data by the KNN algorithm is based on a voting system of the K-nearest neighbors. The measurements of distances between the  $FD$  target and the items of the clusters are carried out on the basis of the Minkowski distance [20], where the formula is described as follows:

$$M_{dist} = (\sum_{i=1}^m (|x_i - y_i|)^p)^{\frac{1}{p}} \quad (1)$$

where  $x_i$  and  $y_i$  are respectively the coordinates of two points  $X$  and  $Y$ , while the parameters:  $m$  and  $p$  are selected by the user. (For the proposed application we set  $m=3$  and  $p=3$ ).

The final decision is performed after the assignment processing of  $FD$ ; If  $FD$  is assigned to the fire cluster, the decision denoted  $F_{dec}$  switches to '1'. Otherwise it remains to '0'. (see Figure8).

## B. Energy Model Based

Regarding the energy aspect of the proposed global model, the utilization of the radio model of the first order is considered in theoretical calculation as adopted in [8] (see Figure6):

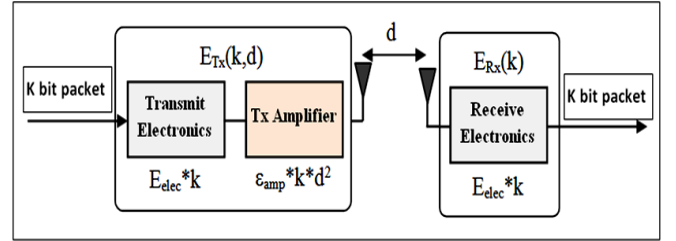

Figure6: Energy model of the first order radio

And to concretize the environment studied in this work, some hypotheses are defined before:

- All sensor nodes have similar characteristics and performance.
- BS has infinite energy and is located outside the surveillance zone.
- The sensor nodes are randomly deployed in a restricted environmental zone.
- The sensor nodes and the BS are always in static and fixed position.
- All sensor nodes have the ability to be an IN node, and a CH node and to perform data fusion processing.
- All sensor nodes have the ability to switch between sleep and wake up modes.

Then, to transmit a message of  $k$  bit for a distance of  $d$ , the energy consumed by the radio [8], is then:

$$E_{Tx}(k, d) = k \times E_{elec} + \epsilon_{efs} \times k \times d^2 \quad (d \leq d_{th}) \quad (2)$$

$$E_{Tx}(k, d) = k \times E_{elec} + \epsilon_{amp} \times k \times d^4 \quad (d > d_{th}) \quad (3)$$

And in the case of receiving a message of  $k$  bit, the energy cost by radio [8], is:

$$E_{Rx}(k, d) = k \times E_{elec} \quad (4)$$

Where  $E_{elec}$  represents the energy consumed within the transmission and reception electronics blocks, while  $\epsilon_{efs}$  represents the amplification energy expended for data transmission when the distance is less than  $d_{th}$ , and in the case where distance is greater than  $d_{th}$ , the transmission amplification energy becomes represented by  $\epsilon_{amp}$ .



IV. PERFORMANCE SIMULATION

A. Data Fusion Performance

1) First Level Process

The reasoning of simulation will be conducted in this section based on the temperature coordinate data, in the same way; this simulation application is assumed identical for other types of sensors.

A simulation of the Receiver Operating Characteristic (ROC) curves [20, 21] was studied in order to evaluate the performance of the data sorting method. This performance test based on a calculation of the probabilities of detection (denoted  $P_D$ ) and false alarm (denoted  $P_F$ ) to which they reflect a good performance when the detection probability is important while maintaining a lower level of the probability of false alarm. So, for this simulation, we took the previous issue where we have  $(N+1)$  temperature sensors in the cluster of the analysis area, with  $N = 20$ ; of which: ten aggregated temperature samples are provided from functional nodes, five samples are provided from functional nodes and still far from the fire zone, and finally, six incorrect or noisy samples are supposed transmitted from defaulting or failing sensors. The improvement in performance using the proposed application is illustrated in Figure7.

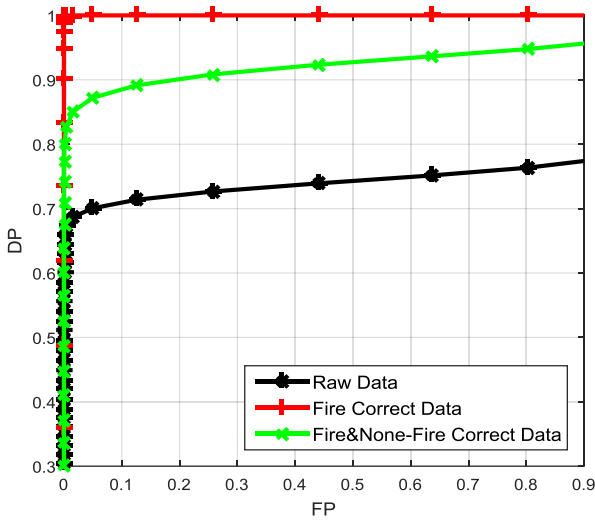

Figure7: Evolution of ROC performance after clustering and fusing data by K-medoids with respect to temperature coordinate.

According to Figure7, it is clear that the ROC curve based on the sorted data vector shows a better performance compared to that of raw data and this is explained by the diminution of the noise parameter (denoted as  $\sigma$ ) of intra-cluster, by applying the K-medoids clustering, which, therefore, leads to increasing the probability of detection.

2) Second Level Process: Output Estimation

Figure 8 describes the response of the decision developed by the KNN classifier, which is fed in the input by a variation of the Fused Data (FD) in its three coordinates (resulting from the first fusing level). This response is elaborated over a time axis.

The simulation is performed in the analysis area that includes twenty-one nodes. Starting with five sensors nodes detecting fire and six other nodes are assumed in failure mode and deliver erroneous data, while ten other sensors are,

at first, supposedly located far from the fire event location. The propagation of fire in this simulation is carried out during ten processing sequences. In each sequence, it is assumed that a new sensor detects the fire and therefore it joins the fire data cluster.

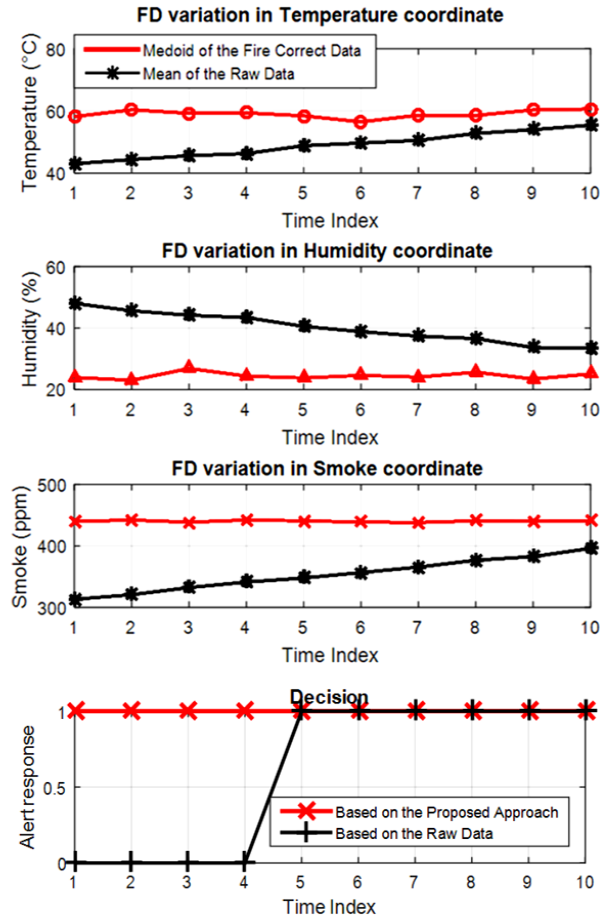

Figure8: The final decision performed by KNN with respect to FD variations in its three coordinates over ten sequences (we set:  $K = 7$ )

The rapidity of the alert and the vigilance of the system are also among the features of our proposed approach, where detection can be directly triggered if a minimum number of neighboring sensors nodes detect the fire ( $C_{min}=5$  first data belonging to the cluster) as in Figure8. In addition, this alert can be used to prevent fire propagation as quickly and reliably as possible before it burns a large area.

3) Interpretation

The primary level of data sorting is an important step allowing the refinement of data against possible errors; and on the other hand, it allows distinguishing between the correct data detecting fire and the correct data provided from the sensors which are still far from the event. It, therefore, contributes to removing unnecessary data in the overall treatment, and thus, increases the reliability of the system.

This merged information extracted from the first level plays an essential role in the decision made by KNN in the final level. It also allows the system to be more vigilant, sensitive and rapid in triggering the alert since the very beginning of event while maintaining the good detection reliability.

### B. Energy Consumption Evaluation

Concerning the impact of the proposed approach on WSN in terms of energy consumption and lifetime extending, a simulation experiment is done, comparing this proposed technique to LEACH (Low-Energy Adaptive Clustering Hierarchy) [8] and to M-GEAR (Gateway-Based Energy-Aware Multi-Hop Routing Protocol) [15] and to SEP (Stable Election Protocol) [24] and to TEEN (Threshold sensitive Energy Efficient sensor Network) [25] with the base on the simulation parameters defined in Table 1.

Table 1  
Simulation Parameters

Parameter	Value
Network area	100m x 100m
Number of network nodes	200
Number of fire cluster nodes	21 (20 CMs +1 CH)
Initial energy of node	0.1 J
Transmitter Electronics	50 nJ/bit
Receiver Electronics	50 nJ/bit
Sleep Energy	5nJ/bit
Transmit amplifier ( $\epsilon_{amp}$ ) (When $d > d_{th}$ )	0.0013 pJ/ bit/m <sup>4</sup>
Transmit amplifier ( $E_f$ ) (When $d \leq d_{th}$ )	10 pJ/ bit/m <sup>2</sup>
Number of Rounds	1300
Data transmission	4000 bit

The simulation is prepared over 200 nodes randomly scattered in a surface of 100m x100m, the Sink is located outside the zone, and its location is (150m, 50m), we consider at the first round that the fire is generated close to the node whose location is (0,0) and which is furthest from the Sink. The simulations of the algorithms are executed during 1300 rounds, their performance results are illustrated in Figure9, and Figure10.

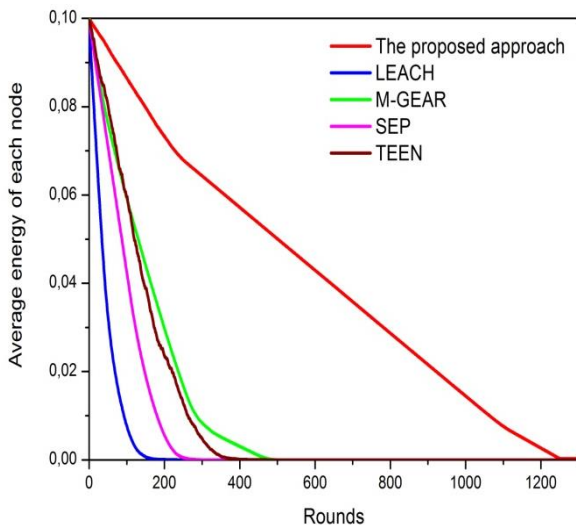

Figure9: The average energy of network node

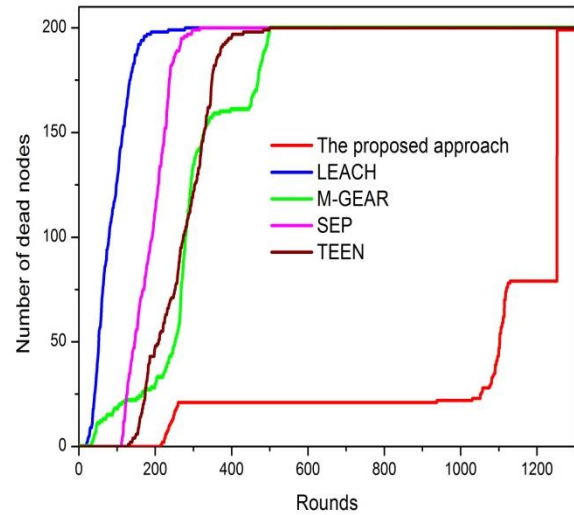

Figure10: The number of nodes dying during 1300 rounds

Figure 9. shows the comparison of the energy consumption of each node belonging to the network (on average) on the three approaches, as illustrated, the energy consumed when the proposed approach is applied much less than those obtained with LEACH, SEP, TEEN, and M-GEAR. This seems more reasonable since, in the proposed work, when the first fire appears, there is only one analysis cluster examined and operated in this zone. Whereas the case of LEACH, SEP, TEEN, and M-GEAR where the whole zone is divided into several clusters. Thus, these approaches make it possible to exploit all the nodes of the platform. This interpretation proves that the proposed approach outperforms these existing routing techniques in a wisely energy consumption.

Regarding Figure10, it illustrates the curves of the dead nodes in the three approaches during 1300 rounds, as shown, the network using LEACH is the first to die, followed by the networks using SEP, TEEN, and M-GEAR. However, the network using the proposed approach remains alive without any dead node until after 200 rounds where the nodes begin to die progressively until reaching  $(N+1)$  dead nodes in the vicinity of 250 rounds where the curve becomes stable. These  $(N+1)$  dead nodes are essentially the nodes of the analysis cluster. It is evident, as the nodes of this cluster area are more exploited in radio communication than other nodes in the network area, and therefore they are likely to be the first to die in this proposed approach. from 1050 rounds to 1120 rounds we can notice another dead node added, these sensor nodes represent the IN nodes previously exploited outside the cluster, and which they returned, after, to their normal state, working as the other external nodes, finally the last nodes that die are the rest of network nodes that were far from the event and that were not concerned with wireless data communication, their lifetime is prolonged by a periodic changeover of states between the sleep state where the radio module is deactivated, and the wake-up state where these sensors update their measurements and remain vigilant of a possible detection where keeping also their radio module in the listening state. ( $T_s > T_w$ ).

All this, conclude that on the basis of these simulation results, our approach ensures an efficient energy consumption of network nodes, making it possible to extend more the overall network lifetime.

## V. CONCLUSION

In the context of improving the performances of the WSN system applied for environment protection against fires, this paper describes a hybrid model integrating the fusion method of acquired multi-sensor data combined with an intelligent information routing technique that takes into account the appearance of the fire event. This system basically has used the concept of clustering which includes nodes that are closest to the event, which is detected beforehand by the first nearest sensor node.

Data fusion is initiated within the elected CH node in order to reliably estimate the state of the analysis cluster area. It consists of two hierarchical levels using, initially, a partitioning technique called K-medoids to sort and merge the correct data from temperature, humidity and smoke type sensors. The output at this level is a three-dimensional coordinate sample, which is represented as a merged data. Such a fused data is processed and classified by the KNN classifier to obtain an overall estimated decision describing the status of this area. And in the case of a positive decision reflecting the existence of the fire, the CH transmits an alert message to the Sink through the elected IN node which is located outside the cluster.

The proposed system is able to avoid, through its processing, a redundant, incorrect or useless data making it possible to increase the detection reliability based on the fused data and, in the same time, to minimize the energy consumption of the node which promotes a good extension of WSN's lifetime.

## REFERENCES

- [1] K. Sohrawy, D. Minoli, T. Znati, *Wireless sensor networks: technology, protocols, and applications*, John Wiley & Sons, 2007.
- [2] A.A.A. Alkhatib, "A Review on Forest Fire Detection Techniques", *International Journal of Distributed Sensor Networks*, vol. 10, issue: 3, (2014).
- [3] M .A. El abbassi, A. Jilbab, A. Bourouhou, "A robust model of multi-sensor data fusion applied in wireless sensor networks for fire detection", *International Review on Modelling and Simulation (IREMOS)*, vol. 9, N. 3, pp. 173-180, June 2016.
- [4] M .A. El abbassi, A. Jilbab, A. Bourouhou, "Hybridized Model for Early Detection and Smart Monitoring of Forest Fire", *Transaction on machine learning and artificial intelligence*, vol. 5, no. 4, 2017.
- [5] M .A. El abbassi, A. Jilbab, A. Bourouhou, "Detection model based on multi-sensor data for early fire prevention", *IEEE ICEIT 2016, tangier Morocco*, pp. 214 - 218, 2016.
- [6] B.Khaleghi, A. Khamis, F.O Karray, S.N. Razavi, "Multisensor data fusion :A review of state-of-the-art", *Information fusion*, vol. 14 pp. 28-44, 2013.
- [7] B. Sharma, A. A. Pillai, P. Saranya, "Application of data fusion and sensor head algorithm for data extraction from wireless sensor networks", *Indian journal of science and technology*, vol. 9, 2016.
- [8] W.R.Heinzelman, A.Chandrakasan , H. Balakrishnan, "Energy-efficient communication protocol for wireless microsensor networks", *The Hawaii International Conference on System Sciences*, January 4-7, Maui, Hawaii, 2000.
- [9] D.Izadi, J.H. Abawajy, S. Ghanavati , T .Herawan, "A data fusion method in wireless sensor networks", *Sensors*, 15, 2964-2979, 2015.
- [10] K.S. Arikumare, V. Natarajan, L. Sushma, "Efficient fuzzy logic based data fusion in wireless sensor networks", *Online International Conference on Green Engineering and Technologies (IC-GET)*, Coimbatore, pp. 1-6, 2016.
- [11] S. Das, S. Barani, S. Wagh, S.S. Sonavane, "Extending lifetime of wireless sensor networks using multi-sensor data fusion", *Sadhana - Academy proceedings in engineering sciences*. vol. 42, no.7, pp. 1083–1090, 2017.
- [12] K. Zhang, C. Li, W. Zhang, "Wireless sensor data fusion algorithm based on the sensor scheduling and batch estimate", *International journal of future computer and communication*, vol. 2, no.4, 2013.
- [13] V. Khanna, R. K. Cheema, "Fire Detection Mechanism using Fuzzy Logic", *International Journal of Computer Applications*, vol.65, no.12, 2013.
- [14] O. Sekkas, S. Hadjieftymiades, E. Zervas, "A Multi-level Data Fusion Approach for Early Fire Detection", *In Intelligent Networking and Collaborative Systems (INCOS), 2nd International Conference*, pp. 479- 483, 2010.
- [15] Q.Nadeem, M. B. Rasheed, N. Javaid, Z. A. Khan, Y. Maqsood, A. Din, "M-GEAR: Gateway-Based Energy-Aware Multi-Hop Routing Protocol for WSNs", *IEEE Eighth International Conference on Broadband, Wireless Computing, Communication and Applications*, France, 2013.
- [16] L.Kaufmann, P.J.Rousseeuw, *Clustering by means of Medoids, in Statistical Data Analysis Based on the L1-Norm and Related Methods*, edited by Y. Dodge, North-Holland, 405–416, 1987.
- [17] L.Kaufmann, P.J.Rousseeuw, *Finding Groups in Data: An Introduction to Cluster Analysis*. Hoboken, New Jersey: John Wiley & Sons, 2009.
- [18] D. Coomans, D.L. Massart, "Alternative k-nearest neighbour rules in supervised pattern recognition: Part 1. k-nearest neighbour classification by using alternative voting rules". *Analytica Chimica Acta*, vol.136, 15-27, January 1982.
- [19] V. Kotu, B. Deshpande, *Predictive Analytics and Data Mining*, chapitre 4, Pages 63-163, 2015.
- [20] K. Teknomo, *Similarity Measurement*, Retrieved from: <http://people.revoledu.com/kardi/tutorial/Similarity/MinkowskiDistance.html> . [accessed 2015]
- [21] K. Hajian-Tilaki, "Receiver Operating Characteristic (ROC) Curve Analysis for Medical Diagnostic Test Evaluation", *Caspian Journal of Internal Medicine*, 4(2), pp. 627-635, 2013.
- [22] H.J.A. "Receiver operating characteristic (ROC) methodology: the state of the art". *Crit Rev Diagn Imaging*; 29, pp. 307-35, 1989.
- [23] MacQueen, J. B. "Some Methods For Classification And Analysis Of Multivariate Observations. Proceedings Of 5th Berkeley Symposium On Mathematical Statistics And Probability", *University of California Press*. pp. 281–297 (1967) Retrieved in 2009.
- [24] G. Smaragdakis, I. Matta, A. Bestavros, "SEP: A Stable Election Protocol for Clustered Heterogeneous Wireless Sensor Networks", *In Second International Workshop on Sensor and Actor Network Protocols and Applications (SANPA 2004)*, 2004.
- [25] A. Manjeshwar and D. P. Agrawal, "TEEN: a routing protocol for enhanced efficiency in wireless sensor networks", *Proceedings 15th International Parallel and Distributed Processing Symposium. IPDPS 2001*, San Francisco, CA, USA, 2001, pp. 2009-2015.