



## Scholars' Mine

---

[Masters Theses](#)

[Student Theses and Dissertations](#)

---

Fall 2008

### Design for manufacturing for friction stir welding

Harish Bagaitkar

Follow this and additional works at: [https://scholarsmine.mst.edu/masters\\_theses](https://scholarsmine.mst.edu/masters_theses)

 Part of the [Manufacturing Commons](#)

Department:

---

#### Recommended Citation

Bagaitkar, Harish, "Design for manufacturing for friction stir welding" (2008). *Masters Theses*. 6722.  
[https://scholarsmine.mst.edu/masters\\_theses/6722](https://scholarsmine.mst.edu/masters_theses/6722)

This thesis is brought to you by Scholars' Mine, a service of the Missouri S&T Library and Learning Resources. This work is protected by U. S. Copyright Law. Unauthorized use including reproduction for redistribution requires the permission of the copyright holder. For more information, please contact [scholarsmine@mst.edu](mailto:scholarsmine@mst.edu).



**DESIGN FOR MANUFACTURING FOR FRICTION STIR WELDING**

**by**

**HARISH BAGAITKAR**

**A THESIS**

**Presented to the Faculty of the Graduate School of the**

**MISSOURI UNIVERSITY OF SCIENCE AND TECHNOLOGY**

**In Partial Fulfillment of the Requirements for the Degree**

**MASTER OF SCIENCE IN MANUFACTURING ENGINEERING**

**2008**

**Approved by**

**Venkat Allada, Advisor**

**Rajiv Mishra**

**Frank Liou**

© 2008  
Harish Bagaitkar  
All Rights Reserved

*This work is dedicated to my father, the late Mr. Sadanand Bagaitkar, my mother Mrs. Shobhana Bagaitkar, my uncle Mr. Yashwant Khanapurkar, and my aunt Mrs. Vimal Khanapurkar.*

## **PUBLICATION THESIS OPTION**

The thesis consists of two separate research papers; Paper I and Paper II.

Paper I has been published at the Proceedings of the ASME 2008 International Design Technical Conferences & Computers and Information in Engineering Conference – New York City, NY, USA.

(Page Number 1 to 27)

Paper II has been published at the Proceedings of the ASME 2008 International Conference on Manufacturing Science & Engineering – Evanston, IL, USA.

(Page Number 29 to 47)

## ABSTRACT

This thesis is divided in two parts. In the first part, technical feasibility of implementing Friction Stir Welding (FSW) for automobile chassis fabrication is discussed using a case study. In the case study, Design for Manufacturing (DFM) principles are applied to manufacture an aluminum automobile chassis. Various DFM issues such as Tool Accessibility Issue, Joint Configuration Issue, and Fixture Support Issue along with relevant guidelines such as component geometry change and component elimination are discussed in the first section. Results show that more than 50% of the chassis joints can be welded using FSW technique. The second part of the thesis describes efforts to develop a web-based E-Design Tool for the FSW technique. The E-Design Tool accepts joint specifications from the user and generates a set of process parameters that may be used as process design guidelines by engineers and researchers who work on FSW. The E-Design Tool can serve as a useful tool for process parameter selection for designers, engineers, and researchers who work on the FSW technique.

## ACKNOWLEDGMENTS

I would like to take this opportunity to thank the people who have helped me accomplish this research effort.

I am extremely grateful to my advisor, Dr. Venkat Allada, for his guidance, advice, and consistent encouragement. He has been a tremendous source of motivation. I would also like to thank my thesis committee member, Dr. Rajiv Mishra, for his continuous support throughout my work. I appreciate the time taken by both, Dr. Venkat Allada and Dr. Rajiv Mishra to discuss valuable research approaches and results. I wish to express my sincere gratitude to my committee member, Dr. Frank Liou, for his insightful comments.

In addition, I would like to further acknowledge the support of my team members and friends, Pradeep Tipaji and Kamini Gupta, for participating in thought-provoking discussions and encouraging me in this work. I would also like to thank Abhijit Choudhury, Padmavathi Krishna Pakala, Mohit Goswami, Salik Ram Yadav, and Deepak Tickoo for their encouragement and moral support during my master's program.

Last but not the least, I would like to thank my father, the late Mr. Sadanand Bagaitkar and my mother, Mrs. Shobhana Bagaitkar, for their encouragement and the trust they bestowed on me. Also, I am thankful for the love and emotional support of my wife Sayali Peshave, and her family.



## TABLE OF CONTENTS

	Page
PUBLICATION THESIS OPTION.....	iv
ABSTRACT.....	v
ACKNOWLEDGMENTS .....	vi
LIST OF ILLUSTRATIONS.....	ix
LIST OF TABLES.....	x
PAPER I. DESIGN FOR MANUFACTURING (DFM) METHODOLOGY TO IMPLEMENT FRICTION STIR WELDING (FSW) FOR AUTOMOBILE CHASSIS FABRICATION	
1. INTRODUCTION .....	2
2. DESIGN FOR MANUFACTURING ISSUES.....	5
2.1. Tool Accessibility Issue .....	5
2.1.1. Tool Accessibility Issue - 1.....	6
2.1.2. Tool Accessibility Issue - 2.....	10
2.2. Joint Configuration Issue.....	11
2.2.1. Joint Configuration Issue - 1.....	12
2.2.2. Joint Configuration Issue - 2.....	13
2.3. Fixture Support Issue.....	14
3. COMPONENT ELIMINATION .....	16
4. JOINT CATEGORIZATION .....	18
5. PERFORMANCE FEASIBILITY OF FSW JOINTS .....	19
5.1. Joint Testing - MIG welded joints.....	21
5.2. Joint Strengths - MIG and FSW.....	23
6. RESULTS AND CONCLUSIONS.....	24
7. FUTURE WORK .....	25
ACKNOWLEDGEMENTS.....	26
NOMENCLATURE .....	26
REFERENCES .....	27

PAPER II. E - DESIGN TOOL FOR FRICTION STIR WELDING (FSW)

1. INTRODUCTION .....	30
2. THE FSW DATABASE .....	31
3. THE E – DESIGN TOOL .....	32
3.1. Assumptions for the E-Design tool.....	33
3.2. Inputs for E-Design Tool .....	33
3.2.1. Step 1: Selection of welding technique.....	33
3.2.2. Step 2: Selection of component geometry and material.....	34
3.2.3. Step 3: Selection of joint category.....	35
3.2.4. Step 4: Selection of mating/aligning faces and the base component .	36
3.2.5. Step 5: Specifying the joint strength.....	37
3.2.6. Step 6: Specifying the weld category.....	38
3.3. Outputs of the E-Design Tool .....	39
4. INPUT – OUTPUT RELATIONS.....	42
5. RESULTS AND CONCLUSIONS.....	44
6. FUTURE WORK.....	45
ACKNOWLEDGEMENTS.....	46
REFERENCES .....	47
VITA.....	48

## LIST OF ILLUSTRATIONS

### PAPER I

Figure 1: Lap Welding Using FSW Process.....	2
Figure 2: FSW Tool Head and FSW Tool.....	6
Figure 3: Interference of Tool Shoulder and Tool Head With the Component.....	7
Figure 4: Avoidance of Tool Shoulder Interference With Component-2.....	7
Figure 5: Avoidance of Tool Head Interference With Component-2.....	9
Figure 6: Welding Operation From Top Side.....	10
Figure 7: Welding Operation From Bottom Side.....	11
Figure 8: T-Joint Between Component-1 and Component-2.....	12
Figure 9: Geometry of Component-2 Changed to Convert T-Joint into Lap Joint.....	13
Figure 10: Metallic Piece Added at the Corner to Facilitate FSW for the T-Joint.....	13
Figure 11: T-Joint Configuration With FSW.....	14
Figure 12: Joint Between Thin Walled Hollow Tube and Sheet.....	15
Figure 13: MIG Welded Joint With Component-3.....	16
Figure 14: Proposed FSW Joint Without Component-3.....	16
Figure 15: Aluminum Chassis Used for Functional Feasibility Study.....	18
Figure 16: Aluminum Chassis Used for Performance Feasibility Study.....	21
Figure 17: Test Coupons for MIG Welded Joint.....	22

### PAPER II

Figure 1: E-Design Tool Flowchart.....	32
Figure 2: Screenshot of Window for Selection of Welding Technique.....	34
Figure 3: Screenshot of Window for Selection of Component Geometry and Materials..	35
Figure 4: Screenshot of Window for Joint Category Selection .....	36
Figure 5: Screenshot of Window for Selection of Mating/Aligning Faces and Base Component.....	37
Figure 6: Screenshot of Window for Specifying Joint Strength.....	38
Figure 7: Screenshot of Window for Specifying Weld Category.....	39
Figure 8: Screenshot of Output Window.....	40
Figure 9: Screenshot of Design Suggestion Window.....	41

**LIST OF TABLES****PAPER I**

Table 1: Joint List for Automobile Chassis.....	20
Table 2: Strengths of MIG Welded Joints.....	22

**PAPER II**

Table 1: Year of Origin for Various Welding Techniques.....	30
Table 2: Options for Component Geometries and Materials.....	34
Table 3: Input and Output Parameters for the E-Design Tool.....	43

## PAPER - I

# Design for Manufacturing (DFM) Methodology to Implement Friction Stir Welding (FSW) for Automobile Chassis Fabrication

**Harish Bagaitkar<sup>‡</sup> and Venkat Allada\***

<sup>‡</sup>Graduate student, Sustainable Design Laboratory, Engineering Management Building,  
Missouri University of Science and Technology, Rolla, MO. 65409.

[hbagitkar@gmail.com](mailto:hbagitkar@gmail.com)

\*Corresponding Author: Professor, Engineering Management & Systems Engineering  
Department, and Vice-Provost for Graduate Studies

119 Fulton Hall, Missouri University of Science and Technology, Rolla, MO. 65409.

[allada@mst.edu](mailto:allada@mst.edu)

### ABSTRACT

*The manufacturing functional feasibility of implementing Friction Stir Welding (FSW) for automobile chassis fabrication is discussed using a case study that applies Design for Manufacturing (DFM) principles for manufacture of an aluminum automobile chassis. This paper proposes the FSW technique as an alternative to laser welding and metal inert gas welding techniques. Further, it addresses the various DFM issues that arose during investigation. DFM guidelines involving joint design change, component geometries, and component elimination are discussed. By making appropriate changes in the component geometries and joint designs, and by eliminating some components, more than 50% of the joints in the case study could be welded using the FSW technique. The need for a performance feasibility study is discussed, and an example is provided. Joint strength requirements for proposed FSW joints are specified in the performance feasibility study.*

### **Keywords**

Design for Manufacturing (DFM), Friction Stir welding (FSW), automobile chassis

## 1. INTRODUCTION

Friction Stir Welding (FSW) is a solid state welding technique in which a non-consumable rotating tool is used to make a joint between two components. The two components are oriented and clamped with appropriate fixtures. The rotating FSW tool is plunged into the components at the start point of the weld line and traversed along the weld line. Figure 1 shows a lap weld made using the FW technique. The simultaneous rotation and traverse movement of the tool pin and shoulder cause heating of the workpiece, material movement, and accumulation of hot metal under the shoulder. These actions result in a solid state joint between the two components.

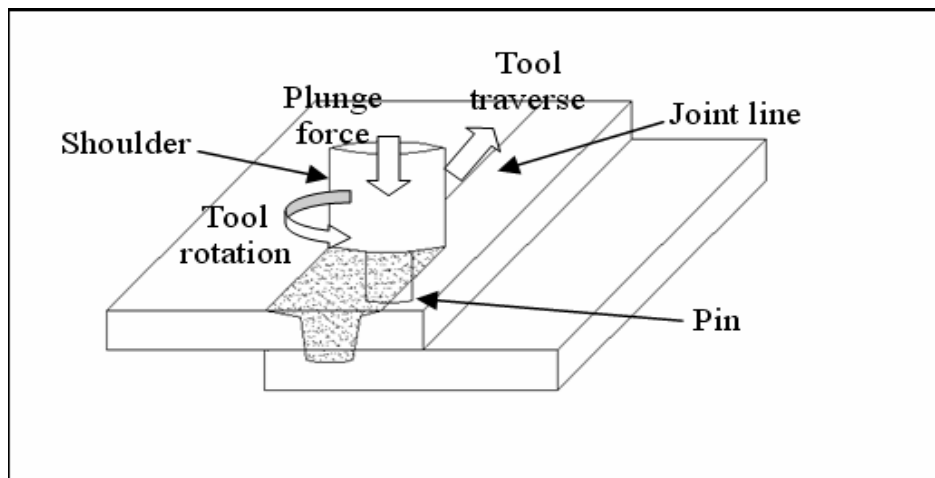

**Figure 1: Lap Weld Using FSW Process**

Presently, the FSW technique is widely used in ship building and aircraft building [1] due to its many advantages over other welding technologies. These advantages include eco-friendliness (no use of shielding gas, no spatter produced during the process, no fumes generated), use of non-consumable tools, elimination of filler material, elimination of shielding gas, and minimal human intervention [1]. The automobile

industry is another area the technique has potential. Efforts are underway made to study how FSW can be used to manufacture automobile body parts such as doors, roofs, and bonnets [2,3]. The chassis (or frame) of any automobile is a structure fabricated by welding together several components. A large amount of welding is required to fabricate the chassis. To date, no effort has been made to study the manufacturing issues encountered in the implementation of the FSW technique for automobile chassis fabrication. Moreover, DFM methodology has not been used to address the challenges faced in automobile chassis manufacture.

A case study was developed to study the feasibility of implementing FSW to join automobile chassis components. The criteria for manufacturing feasibility were purely technical and included both functional feasibility and performance feasibility. Functional feasibility was evaluated based on the following criteria: (a) easy tool accessibility and no tool collisions, (b) simple joint design and configurations, and (c) easy fixturing. The joints were analyzed by an expert in FSW technology who inspected each joint to evaluate the feasibility of changing it. A robotic FSW machine with six degrees of freedom was used to study the weldability of the chassis joints. The automobile chassis used was originally fabricated using Metal Inert Gas (MIG) and Laser Welding (LW) techniques to join various components. The FSW technique is fundamentally different (in terms of welding process, tools, and machines) from MIG and LW techniques. Hence, when evaluating the FSW technique as an alternative to MIG and LW techniques, manufacturing issues such as the Tool Accessibility (TAI), Joint Configuration (JCI) and Fixture Support (FSI) should be considered. Various DFM principles, such as change of

component geometry, joint design, and component elimination, were employed in the case study.

The performance feasibility study determined necessary strengths for the proposed FSW joints. The relationship between strength of MIG welded joints and strength of proposed FSW joints was established.

The automobile chassis used in the case study consists of 28 aluminum components requiring 46 welded joints. Although an effort was made to use the FSW technique to weld every joint of the chassis, this was not possible due to the manufacturing issues mentioned above. The DFM study helps to categorize the chassis joints into two classes: (a) Class-1 joints are joints which can be welded using the FSW technique, with or without the application of DFM principles and (b) Class-2 joints are joints which cannot be welded using the FSW technique despite of the use of DFM principles. Each chassis joint was checked for all manufacturing issues.



## **2. DESIGN FOR MANUFACTURING ISSUES**

In this paper, three manufacturing issues and the relevant DFM principles are discussed in detail. These issues are as follows: (i) Tool Accessibility, (ii) Joint Configuration, and (iii) Fixture Support. These manufacturing issues and principles supply the criteria for the DFM study used to evaluate the functional feasibility of using the FSW technique to fabricate automobile chassis.

### **2.1. Tool Accessibility Issue**

Both tool accessibility issues (TAI-1 or TAI-2) were studied with the assumption that the FSW machine has six degrees of freedom.

The FSW machine uses a tool head to hold the FSW tool. The FSW tool comprises the tool shoulder and the tool pin. Figure 2 is a schematic of a typical FSW tool head and the FSW tool. The FSW tool head is bulkier than the FSW tool. Moreover, in the case of automobile chassis, the geometries of many components cannot be changed. As a result, the FSW tool cannot reach the area intended for the welding operation without interfering with the component or a fixture element. This manufacturing problem is categorized as a Tool Accessibility Issue (TAI). Two types of TAI are as described in sections 2.1.1 and 2.1.2.

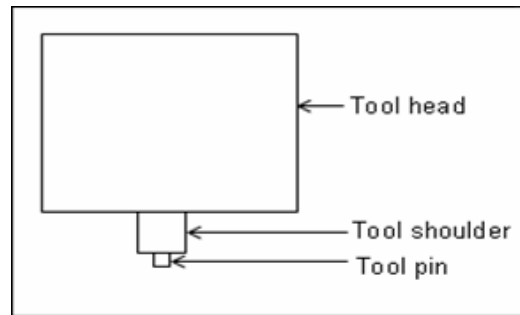

**Figure 2: FSW Tool Head and FSW Tool**

**2.1.1 Tool Accessibility Issue-1 (TAI-1).** Tool Accessibility Issue - 1 is caused by the geometrical shape(s) of one or both components involved in the joint. The joints that belong to the TAI-1 category are those for which the issue of tool accessibility can be handled by changing the geometry of one or both of its components (i.e., extending the overlap portion between the two components). However, changing the component geometry would affect the functionality of the component or product. Also, extra material is introduced thereby negating the advantage of the FSW process. Changing the component geometry is not desirable in such scenarios; hence, TAI-1 joints are not considered weldable using the FSW technique.

Two cases of tool interference are shown in figure 3. The tool shoulder or the tool head can cause the TAI-1 by interfering with the component.

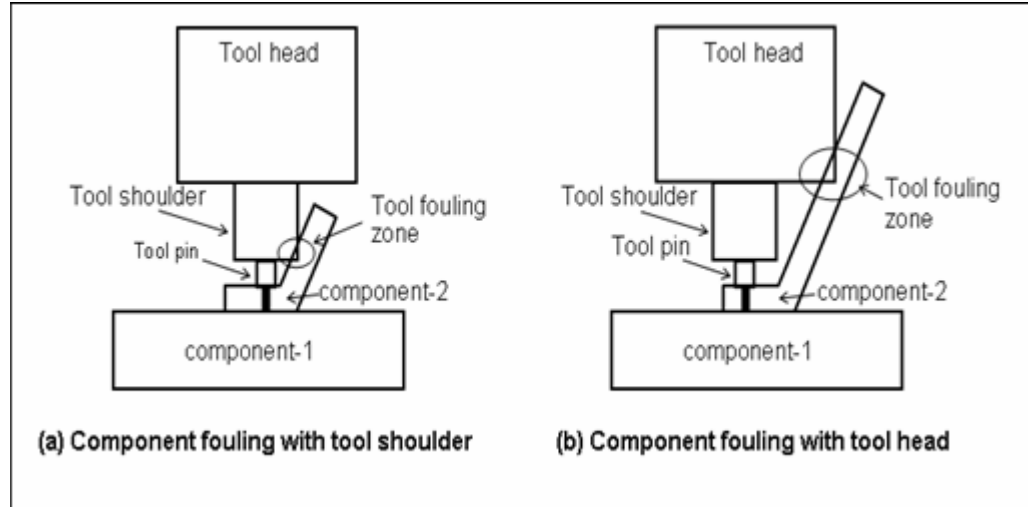

**Figure 3: Interference of Tool Shoulder and Tool Head With the Component**

The issue of tool shoulder interference can be avoided by extending the overlapping portion of component-2 over component-1, as illustrated in figure 4. This change in the geometry of component-2 moves the weld line away from its slant surface, thus preventing the collision with the tool shoulder.

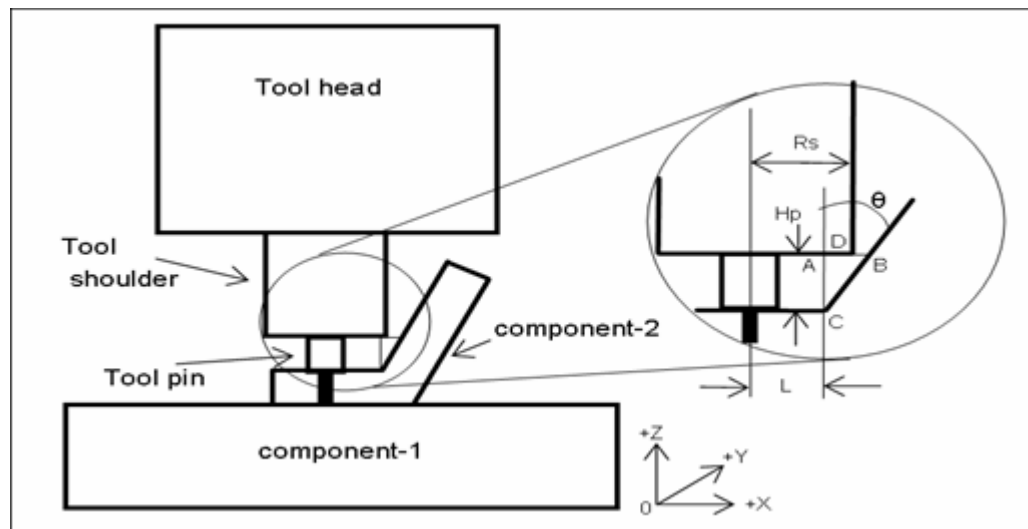

**Figure 4: Avoidance of Tool Shoulder Interference With Component-2**

In order to prevent the collision of tool shoulder with component-2, two mathematical conditions must be satisfied. The condition that must be met to avoid tool shoulder interference with component-2 in horizontal (X and Y) directions is mathematically defined as:

$$H_p \tan \theta + L - R_s > 0 \quad (1)$$

where,

$H_p$  = Pin height (when the tool pin is fully plunged)

$\theta$  = Angle between vertical and slant surface of component-2

$L$  = Distance between center of weld line and point C

$R_s$  = Tool shoulder radius

The condition to avoid tool shoulder interference with component-2 in a vertical (Z) direction is mathematically defined as follows:

$$\text{If } \theta = 0^\circ, CB < H_p \quad (2)$$

where  $H_p$  = Pin height (when the tool is fully plunged)

The issue of tool head interference can be avoided by extending the overlapping portion of component-2 over component-1, as illustrated in figure 5. This change in the geometry of component-2 moves the weld line away from its slant surface, thus preventing the collision with the tool head.

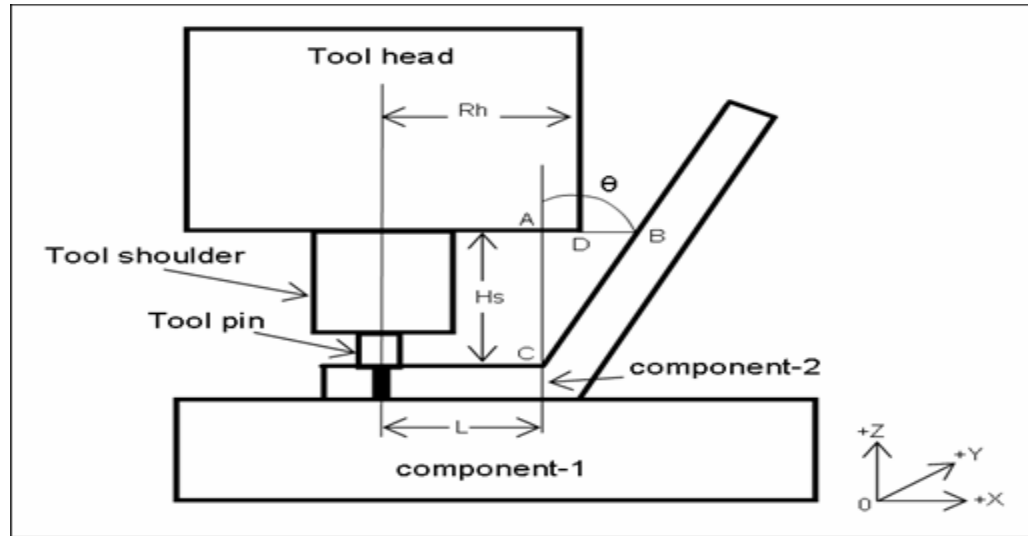

**Figure 5: Avoidance of Tool Head Interference With Component-2**

In order to prevent the collision of the tool head with component-2, two mathematical conditions (equation 1 and equation 2) must be satisfied.

The condition that must be met to avoid tool head interference with component-2 in horizontal (X and Y) directions is mathematically defined as:

$$H_s \tan \theta + L - R_h > 0 \quad (3)$$

where,

$H_s$  = Pin height + shoulder height (when the tool pin is fully plunged)

$\theta$  = Angle between vertical and slant surface of component-2

$L$  = Distance between center of weld line and point C

$R_h$  = Tool head radius

The condition that must be met to avoid tool shoulder interference with component-2 in the vertical (Z) direction is mathematically defined as:

$$\text{If } \theta = 0^\circ, CB < H_s \quad (4)$$

where,  $H_s$  = Pin height + shoulder height (when the tool pin is fully plunged)

In order to prevent the tool from interfering with components having varying cross section along the Y-axis, the conditions (eq.1 through eq.4) should be checked at all the cross sections in the X-Z planes.

Before making any changes in component geometry, effects on component and product functionality should be considered.

**2.1.2 Tool Accessibility Issue-2 (TAI-2).** TAI-2 is also caused by the geometrical shape(s) of one or both components involved in the joint. The corner-shaped portion of component-2 makes it impossible for the tool head to access the intended weld area. If the weld is made from the top (as shown in figure 6), the tool collides with component-2 and the pre-welded component.

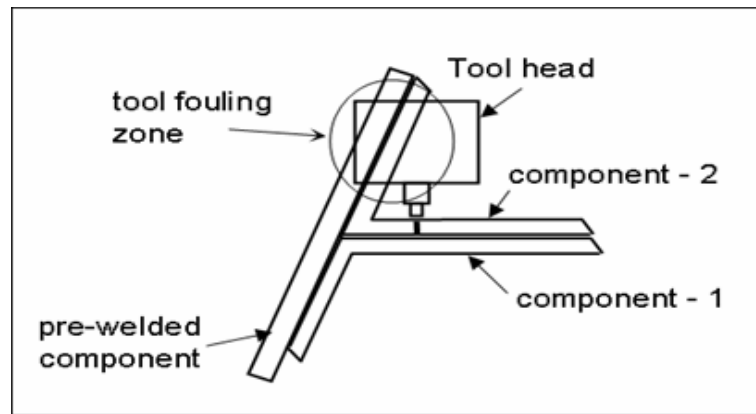

**Figure 6: Welding Operation from Top Side**

If the weld is made from the bottom (as shown in figure 7), the tool collides with pre-welded component.

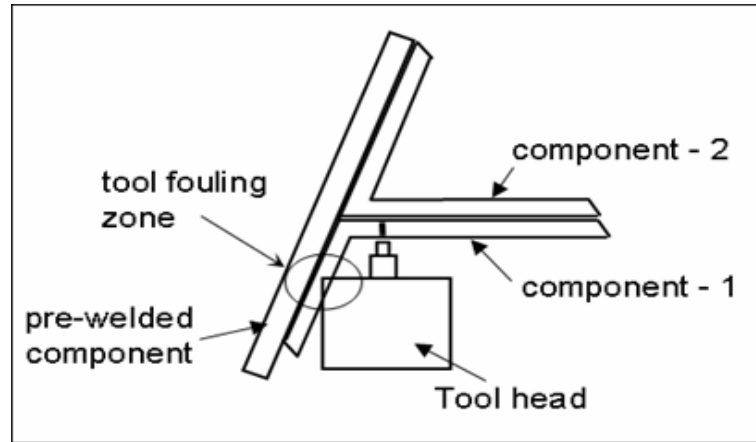

**Figure 7: Welding Operation from Bottom Side**

Component-1 is part of a sub-assembly that includes both, component-1 and the pre-welded component. This tool interference issue cannot be handled by changing the geometry of either component-2 or component-1 by increasing the overlap between the two components (as in TAI-1) because the corner-shaped portion of the component-2 remains inaccessible.

## **2.2 Joint Configuration Issue**

The joints in the automobile chassis used in the case study are of different configurations, including lap joint, butt joint, and tee-corner (T-corner) joint. The use of FSW is well established for lap and butt joints. These FSW welded joints are extensively used in structures built in the marine, aerospace, and automobile industries [1,2]. However, welding of the T-corner joints requires adjustment, giving rise to the Joint Configuration Issue (JCI). Like the TAI, the JCI has two types: JCI-1 and JCI-2.

**2.2.1. Joint Configuration Issue-1 (JCI-1).** A JCI-1 is typically encountered in the T-corner joint configuration between two components. The JCI-1 can be handled by adding a piece of metal along the corner line to facilitate FSW at that line [5]. The issue can also be addressed by changing the geometry of the component to convert the T-joint into a lap joint. Smith *et al.* [6] recommend using lap or butt joints instead of T-joints, however, this method introduces extra material to both lap and butt joints, thereby negating the advantage of the FSW process. Joints having JCI-1 cannot be welded using FSW. Figures 8, 9, and 10 illustrate in detail possible ways of handling a JCI-1. Figure 8 shows the T-corner joint between the two components.

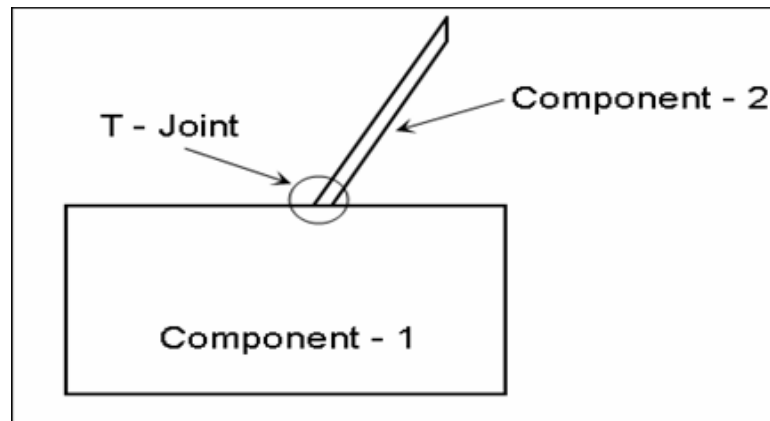

**Figure 8: T-joint Between Component-1 and Component-2**

Figure 9 shows that a JCI-1 can be addressed by changing the geometry of component-2 to convert the T-corner joint into a lap joint. The black line on the extended portion of component-2 would be the weld line for the lap joint. Due to this extension, however, the overall mass of the joint increases, which is not desirable.



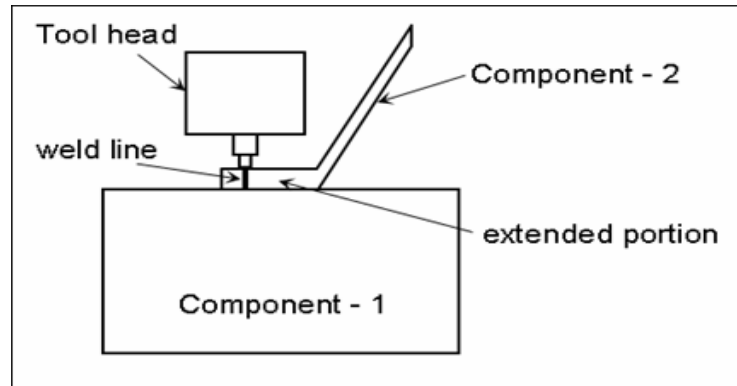

**Figure 9: Geometry of Component-2 Changed to Convert the T-joint into Lap Joint**

In figure 10, a metallic piece is added at the corner line produced between the two components, which also increases the joint's mass.

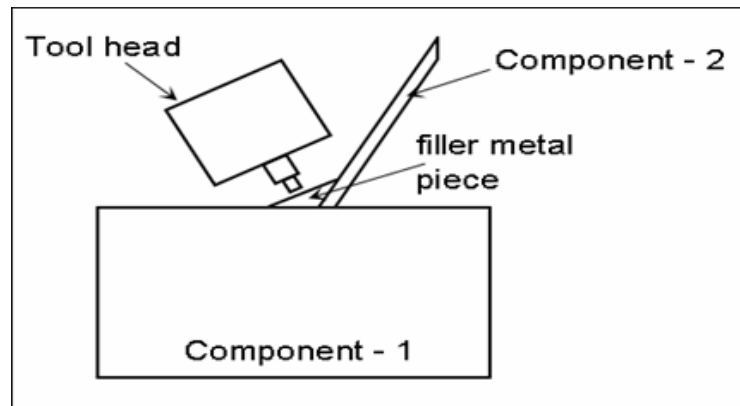

**Figure 10: Metallic Piece Added at the Corner to Facilitate FSW for the T-joint**

**2.2.2 Joint Configuration Issue-2 (JCI-2).** A JCI-2 arises when welding a T-corner joint without changing the geometry of any components or adding any extra metal parts, as shown in figure 11.

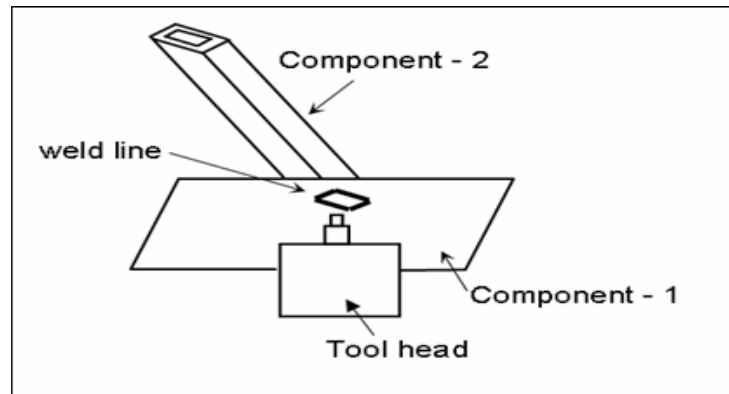

**Figure 11: T-joint Configuration With FSW**

The two components could be joined by making a weld from the underside of component-1. The black square shown in figure 11 on the underside of component-1 is the weld profile. In this case, the tool pin would penetrate from the underside of the component-1 into component-2. However, the wall thickness (assumed to be 3 millimeters) of the hollow component-2 makes it impossible to make a weld in this fashion. Welding in this manner would cause tearing of the walls of component-2 because the tool diameter would typically be approximately 3 mm or more. Hence, JCI-2 cannot be resolved, making it impossible to weld this kind of joint using the FSW technique.

### **2.3. Fixture Support Issue**

FSW (spot welding, stitch welding, or continuous welding) of components requires strong fixture support elements that resist the various forces exerted on the components during the welding process [7]. This requirement is a process constraint for the FSW technique.

The Fixture Support Issue (FSI) is encountered due to the geometrical shapes of the components and the position of joints in the chassis assembly. Typically, an FSI is seen in joints made up of hollow components with low wall thicknesses. To maximize the number of joints that can be welded using the FSW technique, the chassis could be broken down into many sub assemblies constructed at separate stations; however, many joints that must be completed on the assembly line cannot be welded using FSW due to FSI.

Figure 12 shows an example of a joint between component-1 (a hollow tube) and component-2 (a sheet) where an FSI is encountered. The wall of the hollow component-1 is assumed to be 2.5 millimeters thick, requiring an internal support that can resist the force exerted on it during the welding process. Without this internal support, component-1 would be deformed by welding forces.

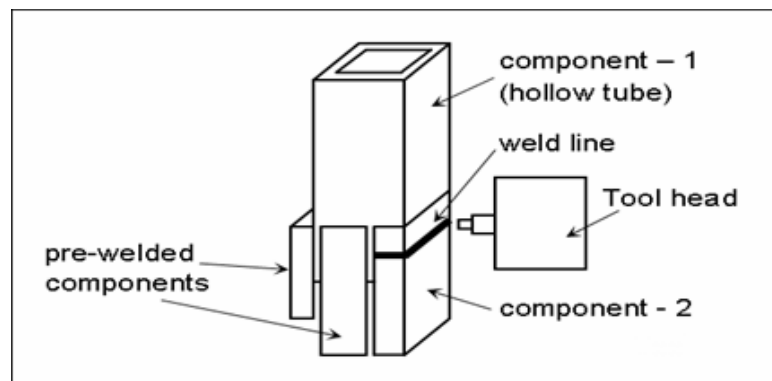

**Figure 12: Joint between Thin Walled Hollow Tube and Sheet**

Due to the pre-welded components around the opening of the hollow tube, however, it is impossible to provide any such internal support, thus eliminating the possibility of making this joint using the FSW technique.

### 3. COMPONENT ELIMINATION

The FSW technique can produce stronger aluminum component joints than can MIG or LW techniques [1]. This advantage of FSW is the basis for employment of the DFM principle of component elimination in the case study.

Figure 13 shows the design of one of the joints in the chassis. Three components, component-1, component-2, and component-3, are involved in the joint. This joint is completed by using the MIG welding technique.

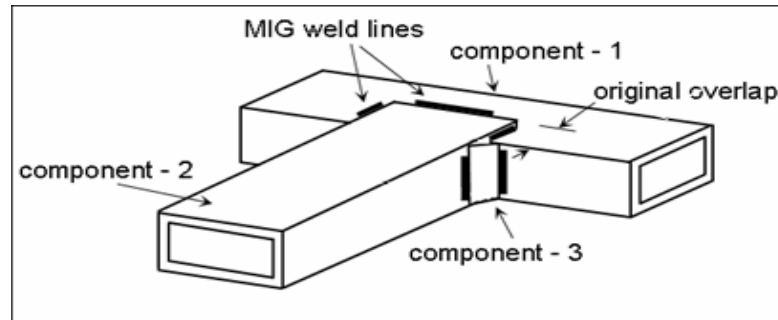

**Figure 13: MIG Welded Joint with Component-3**

Using the component elimination principle, the design of this joint can be modified as shown in figure 14. In the modified joint design, component-3 is eliminated.

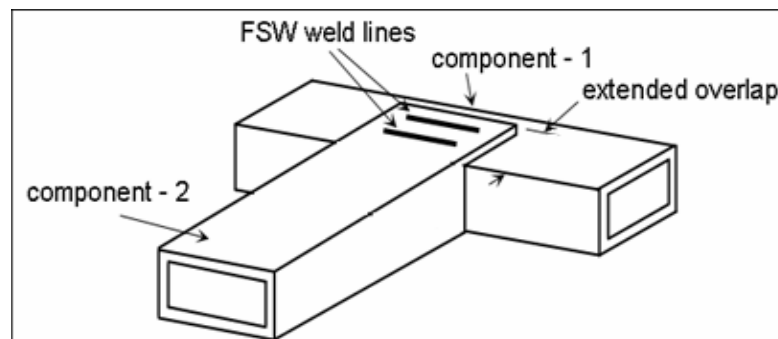

**Figure 14: Proposed FSW Joint Without Component-3**

The overlapping portion of component-2 above component-1 is extended. FSW can be employed on this extended overlapping area. Two or more weld runs can be made in this area to strengthen the joint, thus compensating for the support strength provided by component-3 in the original joint design.

Joint strength evaluation is necessary to validate component elimination. The strength of the MIG welded joint (involving component-3) and the FSW joint (without component-3) should be compared, as discussed in performance feasibility study.

#### 4. JOINT CATEGORIZATION

In order to categorize the joints of the chassis used in the case study (shown in figure 15), each joint was checked to determine the functional feasibility of implementing FSW.

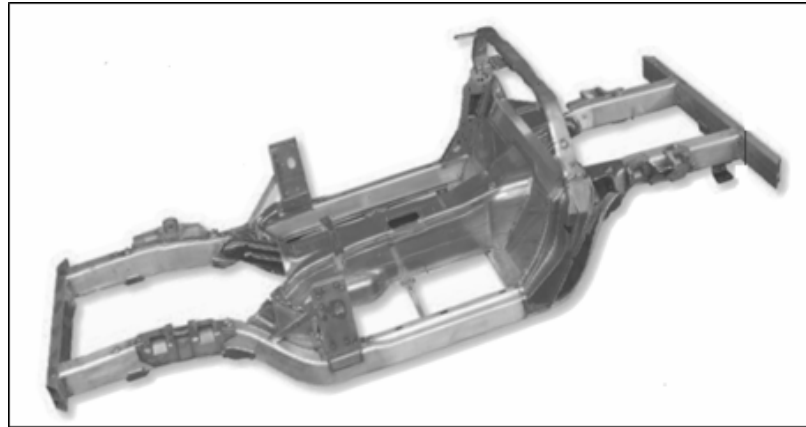

**Figure 15: Aluminum Chassis Used for Functional Feasibility Study**

The Feasibility was determined on the basis of the three issues discussed above: TAI, JCI, and FSI. These issues can be collectively labeled Design for Manufacturing (DFM) issues. If the FSW technique can be used to weld a particular joint without encountering any of these three issues, or if these issues can be resolved using DFM principles, FSW be used on that joint. On the other hand, if one or more of these issues is encountered and cannot be resolved using DFM principles, the FSW technique should not be applied.

## 5. PERFORMANCE FEASIBILITY OF FSW JOINTS

The manufacturing issues (TAI, JCI, and FSI) discussed above determine the functional feasibility of implementing the FSW technique to fabricate an automobile chassis made of aluminum components. Table 1 shows that FSW can be used for 54% of the chassis joints. Those joints for which FSW is feasible either do not have no manufacturing issue, or the manufacturing issue (s) can be resolved by employing DFM principles, as discussed above.

A functional feasibility study is necessary but not sufficient to evaluate the use of FSW for automobile chassis fabrication. A performance feasibility (achievable joint strength) study is also required to decide whether FSW is suitable for automobile aluminum chassis fabrication. MIG welded joints of an automobile chassis were tested in a laboratory to determine the joint strength values. The strength of Class-1 joints listed in Table 1 (proposed FSW joints) must be greater than or equal to that of the corresponding MIG welded joints in order to pass the performance feasibility test.

**Table 1: Joint List for Automobile Chassis**

Joint Number	Joint Components	Joint Type	Joint Station	DFM Issues			Joint Class
J1	C1-C19	Lap Joint	Assembly line				Class-1
J2	C1-C12	Lap Joint	Assembly line				Class-1
J3	C1-C10	Lap Joint	Assembly line				Class-1
J4	C1-C11	Lap Joint	Assembly line	TAI-1			Class-2
J5	C1-C4	Lap Joint	Assembly line				Class-1
J6	C1-C5	Lap Joint	Assembly line				Class-1
J7	C1-C6	Lap Joint	Assembly line				Class-1
J8	C1-C25	Joint eliminated in the proposed design					
J9	C1-C23	Lap Joint	Assembly line				Class-1
J10	C1-C3	Lap Joint	Assembly line				Class-1
J11	C1-C8	Lap Joint	Assembly line				Class-1
J12	C1-C9	Lap Joint	Assembly line	TAI-1			Class-2
J13	C1-C20	Lap Joint	Assembly line				Class-1
J14	C1-C22	T - Joint	Assembly line		JCI-1		Class-2
J15	C1-C26	Lap Joint	Assembly line	TAI-1			Class-2
J16	C1-C28	Lap Joint	Assembly line	TAI-1			Class-2
J17	C1-C15	Lap Joint	Assembly line	TAI-1			Class-2
J18	C12-C7	Lap Joint	Assembly line			FSI	Class-2
J19	C10-C7	Lap Joint	Assembly line			FSI	Class-2
J20	C11-C7	Lap Joint	Assembly line	TAI-1		FSI	Class-2
J21	C27-C7	Lap Joint	S-Assembly				Class-1
J22	C13-C9	Lap Joint	Assembly line				Class-1
J23	C8-C9	Lap Joint	S-Assembly				Class-1
J24	C20-C9	Lap Joint	S-Assembly				Class-1
J25	C24-C10	Lap Joint	Assembly line	TAI-1			Class-2
J26	C11-C10	Lap Joint	S-Assembly				Class-1
J27	C27-C10	Lap Joint	Assembly line				Class-1
J28	C12-C11	Lap Joint	Assembly line	TAI-1		FSI	Class-2
J29	C24-C12	Lap Joint	Assembly line	TAI-1			Class-2
J30	C15-C12	Lap Joint	Assembly line	TAI-1			Class-2
J31	C27-C12	Lap Joint	Assembly line			FSI	Class-2
J32	C8-C13	Lap Joint	Assembly line				Class-1
J33	C19-C15	Lap Joint	Assembly line	TAI-1			Class-2
J34	C14-C16	Lap Joint	Assembly line				Class-1
J35	C17-C16	Lap Joint	Assembly line				Class-1
J36	C24-C16	Lap Joint	Assembly line				Class-1
J37	C19-C16	Lap Joint	S-Assembly				Class-1
J38	C24-C17	Lap Joint	Assembly line				Class-1
J39	C19-C18	Lap Joint	Assembly line	TAI-2		FSI	Class-2
J40	C24-C18	Lap Joint	S-Assembly				Class-1
J41	C22-C21	T - Joint	Assembly line	TAI-1	JCI-2	FSI	Class-2
J42	C26-C21	Lap Joint	S-Assembly				Class-1
J43	C19-C24	Lap Joint	Assembly line	TAI-2			Class-2
J44	C6-C25	Joint eliminated in the proposed design					
J45	C5-C25	Joint eliminated in the proposed design					
J46	C13-C14	Lap Joint	S-Assembly				Class-1



### 5.1. Joint Testing – MIG welded joints

To determine the strength of MIG welded joints, an automobile chassis made of aluminum components was studied. Figure 16 shows the automobile chassis used for the performance feasibility study.



**Figure 16: Aluminum Chassis Used for Performance Feasibility Study**

The chassis is composed of two types of joints, lap joint and T-joint. The chassis was cut into pieces to obtain test coupons of the two joint types suitable for testing. The MIG welded chassis joints were tested for tensile strength. Test coupons (for both lap joints and T-joints) of 0.5 inches width were prepared for the tensile testing. Figure 17 shows a picture of one such test coupon. Table 2 includes the strength values for each joint tested.

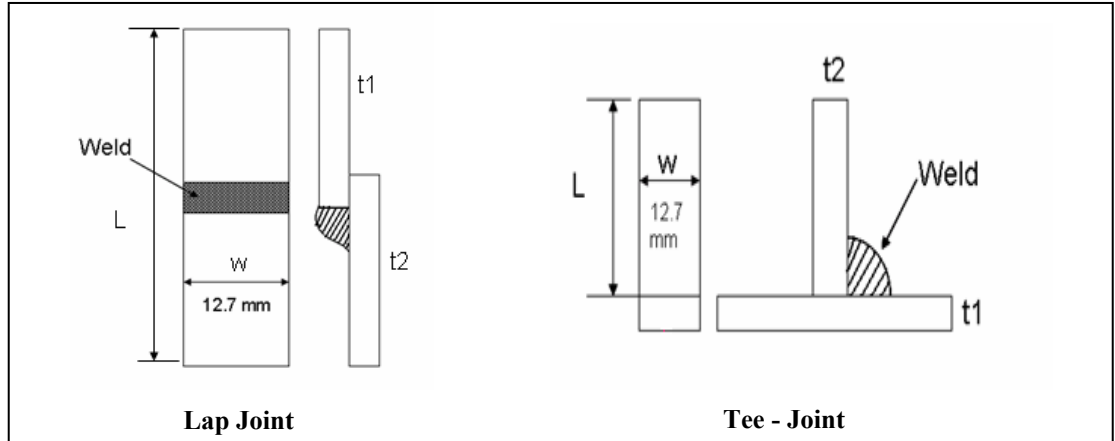

**Figure 17: Test Coupons for MIG Welded Joint**

**Table 2: Strengths of MIG Welded Joints**

<b>Joint No.</b>	<b>Joint Type</b>	<b>Thickness of Part-1 (mm)</b>	<b>Thickness of Part-2 (mm)</b>	<b>Tensile Failure Load (kN)</b>
1	Lap Joint	4.25	5	7.1
2	T-Joint	4.25	4.25	4.1

## 5.2. Joint Strength – MIG and FSW

To pass the performance feasibility test, the strength of the Class-1 joints listed in table 1 (the proposed FSW joints) must be greater than or equal to that of corresponding MIG welded joints (table 2). The conditions for performance feasibility can be mathematically defined as:

(A) For lap joints:

$$\begin{array}{l} \text{Tensile strength of proposed FSW} \\ \text{(Class-1) joints} \end{array} \geq \begin{array}{l} 7.1 \text{ kN (Tensile strength of MIG} \\ \text{welded joints)} \end{array} \quad (5)$$

(B) For T- joints:

$$\begin{array}{l} \text{Tensile strength of proposed FSW} \\ \text{(Class-1) joints} \end{array} \geq \begin{array}{l} 4.1 \text{ kN (Tensile strength of MIG} \\ \text{welded joints)} \end{array} \quad (6)$$

All joints that pass both the functional feasibility test (Class-1 joints in table 1) and the performance feasibility test then those joints could be friction stir welded. Functional feasibility and performance feasibility are the necessary and sufficient conditions to ensure the full technical feasibility of FSW for fabrication of automobile chassis made from aluminum components.

## 6. RESULTS AND CONCLUSIONS

The functional feasibility study proved that 25 out of a total of 46 unique joints welded using MIG or LW techniques in the automobile chassis could be welded using the FSW technique. Once joints J8, J44, and J45 were eliminated from the proposed design, more than 50% of the joints could be welded using the FSW technique. Table 1 lists all joints and their categories (Class-1 or Class-2).

This paper discusses three manufacturing issues associated with the FSW technique as an alternative to MIG and LW techniques. The case study results showed that FSW passed the functional feasibility test for joining over 50% of the joints involved in the automobile chassis.

In general, manufacturing issues such as TAL, JCI, and FSI are relevant to the study of the feasibility of manufacturing automobile chassis using the FSW technique. DFM principles of component geometry change, joint design change, and component elimination can be employed to address the manufacturing issues. Figure 15 shows the chassis used for the case study.

A performance feasibility test should be carried out to ensure that the proposed FSW joints have strength greater than or equal to that of the corresponding MIG welded joints. Functional feasibility tests and performance feasibility tests should be completed to determine the extent to which FSW may be used in automobile chassis fabrication.

## 7. FUTURE WORK

This case study examines the implications of tool accessibility, joint configuration, and fixture support issues for use of the FSW technique as an alternative to the MIG and LW techniques currently used to fabricate automobile chassis. DFM principles such as change in component geometry, joint design, and component elimination are used to address DFM issues.

The performance feasibility study determined the tensile strength of the MIG welded joints and formulated the conditions necessary for the proposed FSW joints to qualify as a substitute for the MIG welded joints. The joints of an automobile chassis are subjected to many other forces such as bending, torsion, and vibration. The next step in a performance feasibility study should include analysis of FSW joints for all such strength factors. Such a study would be necessary for advanced analysis of the joints under all work conditions.

In addition, a cost-benefit analysis is necessary to study the economic feasibility of FSW technique for automobile chassis fabrication and to evaluate potential advantages of the FSW technique, such as higher joint strength, reduced labor, environment friendliness, energy efficiency, and the use of non-consumable tools. The FSW technique should also be compared to MIG and LW techniques on factors such as joint strength, process time, set up time, labor, and chassis weight. Such comparisons would help engineers and managers to determine the extent to which the FSW technique might be used for automobile chassis fabrication.

## ACKNOWLEDGMENTS

This work is supported in part by the National Science Foundation grant number EEC #0632803 and the Engineering Management & Systems Engineering department, Missouri University of Science and Technology. Any opinions, findings, and conclusions, or recommendations presented in this paper are those of the authors and do not necessarily reflect the views of the National Science Foundation, or the Engineering Management & Systems Engineering Department, Missouri University of Science and Technology.

## NOMENCLATURE

<b>Hp</b>	Pin Height (when the pin is fully plunged)
<b>Rs</b>	Tool shoulder radius
<b>Hs</b>	Pin height + Shoulder height (when the pin is fully plunged)
<b>Rh</b>	Tool head radius
<b><math>\theta</math></b>	Angle between vertical and slant surface of component-2

## REFERENCES

- [1] R. S. Mishra and M. W. Mahoney, *Friction Stir Welding and Processing*, published by ASM International, Materials Park, Ohio, 2007, pp. 10-25.
- [2] [www.aluminum.org](http://www.aluminum.org), last visited on January 11, 2008.
- [3] P. Sederstorm:, *Spot Friction Welding of Ultra High Strength Automotive Sheet Steel*, Masters thesis, Brigham Young University, April 2007.
- [4] K. T. Ulrich and S. D. Eppinger, *Product design and development*, Third Edition, McGraw-Hill, New York, 2004.
- [5] T. J. Trapp, T. Stotler, and M. Skilliter, *Friction Stir Welding of corner configurations*, United States Patent 6676008.
- [6] C. B. Smith, J. F. Hinrichs, and W. A. Crusan, *FSW Stirs up Welding Process Competition*, Forming and Fabrication Journal, Vol. 10, No 2, 2003, pp. 3-6
- [7] A. L. Stahl., *Experimental measurements of longitudinal load distributions on friction stir welding tools*, Masters thesis, Brigham Young University, December 2005.
- [8] J. D. Stoll., *How to lose 136 lbs*, Ward's Auto World, June 2005.





## PAPER - II

### E - Design Tool for Friction Stir Welding (FSW)

**Harish Bagaitkar<sup>‡</sup>, Venkat Allada\***

<sup>‡</sup>Graduate student, Sustainable Design Laboratory, Engineering Management Building,  
Missouri University of Science and Technology, Rolla, MO. 65409.

[hbagitkar@gmail.com](mailto:hbagitkar@gmail.com)

\*Corresponding Author: Professor, Engineering Management & Systems Engineering  
Department, and Vice-Provost for Graduate Studies

119 Fulton Hall, Missouri University of Science and Technology, Rolla, MO. 65409.

[allada@mst.edu](mailto:allada@mst.edu)

#### ABSTRACT

*This paper describes efforts to develop a web-based E-Design tool for the Friction Stir Welding (FSW) technique. The input parameters for the E-Design tool are the joint specifications. The output parameters are process parameters such as tool geometry details, tool rpm, and plunge depth. The heart of the E-Design tool is the FSW database. The FSW database contains mappings of various input parameters and output parameters captured from various experimental studies cited in the literature. The proposed E-Design accommodates only lap joints and butt joints between similar aluminum alloys. The E-Design Tool can serve as a useful tool for process parameter selection for designers, engineers, and researchers who work on the FSW technique.*

#### **Keywords**

Fiction Stir welding (FSW), E-Design Tool, FSW Database

## 1. INTRODUCTION

Numerous research studies have examined the application of Friction Stir Welding (FSW) for various aluminum joints [1-9]. Various publications contain data from relevant FSW experiments; however, there exists no repository for this data. Further, the data is dynamic. That is, there are no widely accepted guidelines for selecting process parameters for FSW because the FSW technique is not as fully developed as other better established welding processes. Table 1 lists widely used welding technologies and their approximate year of invention [10].

**Table 1: Year of Origin for Various Welding Techniques**

<b>Welding Technique</b>	<b>Year of Invention</b>
Thermite welding	1893
Oxy Acetylene welding	1900
Resistance welding	1903
Metal inert gas welding	1940
Tungsten inert gas welding	1941
Plasma welding	1957
Laser welding	1960
<i><b>Friction stir welding (FSW)</b></i>	1991

The novelty of the FSW technique makes it difficult for researchers and designers to select process parameters, tools, and machines for experimentation or process design. This paper describes an effort to build a database to hold data collected from various sources relevant to FSW research activities (specifically for aluminum joints). In addition, this paper describes the development and structure of web-based software (E-Design tool) to guide designers in the selection of process parameters to suit specific requirements. The guidelines generated by the E-Design tool are based on relations extracted from the FSW database.

## 2. THE FSW DATABASE

The FSW database is a collection of all process parameters relevant to the FSW technique. The parameters include component material, joint type, weld type, component thickness, tool material, tool pin type, tool pin height, tool pin diameter, tool shoulder diameter, tool shoulder face type, tool shoulder features, plunge depth, plunge speed, tool rpm, tool travel rate, plunge force, torque, dwell time, tool tilt angle, weld length, and joint strength. These parameters are collected from experimental data at the Center for Friction Stir Processing (CFSP) laboratory at Missouri University of Science and Technology (Missouri S&T) and various technical articles on the FSW technique [1-9]. The effect of tool rpm, tool travel rate, and tool geometry on joint strength was studied by Rodrigues *et al.* [1], Jefferson [2], Colligan *et al.* [3], and Reynolds and Tang [4]. In addition, Arul *et al.* [5], Pan *et al.* [6] and Fartini and Zuccarello [7] have demonstrated the relationship between component thickness, plunge depth, plunge force and the joint strength. Guo [8] and Stahl [9] experimented with tool pin shape and tool pin features in FSW. The FSW database forms the foundation for the E-Design tool. The relationships used by the E-Design tool are developed based on the process parameters in the database.

### 3. THE E-DESIGN TOOL

The E-Design tool is an interactive web-based software that serves as a process parameter selector for the FSW technique. The user inputs parameters specifying all the joint requirements. These parameters are then processed by the E-Design tool to generate a set of outputs. The outputs include the parameters necessary to weld the joint per specifications using the FSW technique. Figure 1 explains the six steps of the input process used by the E-Design tool.

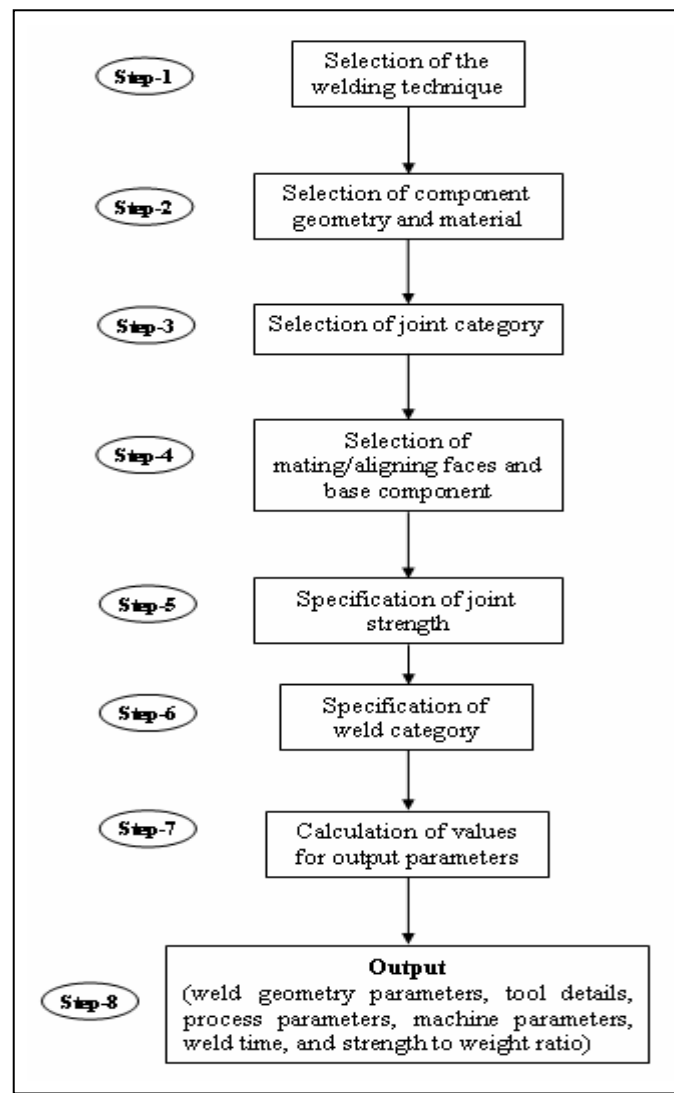

Figure 1: E-Design Tool Flowchart

The user specifies the joint requirements in the first six steps. In step 7, the E-Design tool processes these inputs to calculate output parameters generated in step 8.

### **3.1. Assumptions for the E-Design Tool**

The E-Design tool operates on the following assumptions and rules.

- (a) Components to be joined are of similar aluminum materials.
- (b) All joints will be lap or butt joints.
- (c) For all aluminum varieties density and ultimate tensile strength values are average figures calculated from the ASM Handbook database.
- (d) In the case of spot and stitch welds the spots/stitches are uniformly spaced and equidistant from the component geometry.
- (e) All joints are simple and require linear welds. These joints can be welded only by positioning the FSW tool vertically downwards. Hence, an FSW machine with three degrees of freedom is selected for all inputs.
- (f) An allowance of 500 millimeters is added to the horizontal dimensions for calculating the machine table size to accommodate fixture elements.

### **3.2. Inputs for the E-Design Tool**

The inputs for the E-Design Tool are discussed below in detail.

**3.2.1. Step 1: Selection of welding technique.** A window for selecting the welding technique is displayed. The user selects “FSW” from the available list of welding techniques. Figure 2 shows a screenshot of the window for selection of welding technique.



**Figure 2: Screenshot of Window for Selection of Welding Technique**

**3.2.2. Step 2: Selection of component geometry and material.** Next, a window for component geometry and material is displayed. The user selects the component geometry and material for the two components to be joined. The options for geometries and materials are shown in Table 2.

**Table 2: Options for Component Geometries and Materials**

Component - 1		Component - 2	
Geometry Options	Material Options	Geometry Options	Material Options
Sheet	AA 6061 - T6	Sheet	AA 6061 - T6
Tube	AA 6111 - T4	Tube	AA 6111 - T4
Angle	AA 5182 - O	Angle	AA 5182 - O
Channel		Channel	

A pictorial view of the geometry options is displayed in the same window. Figure 3 shows a screenshot of the window for selection of component geometry and materials.

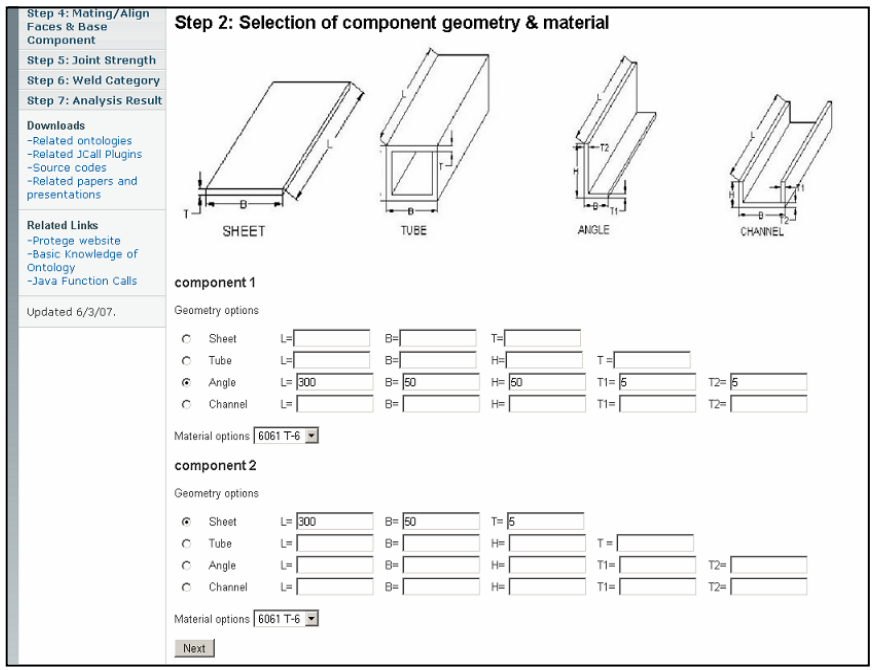

**Figure 3: Screenshot of Window for Selection of Component Geometry and Materials.**

**3.2.3. Step 3: Selection of joint category.** In the next step, the user selects the category of joint required. The two options available for joint categories are lap joint and butt joint. Figure 4 shows a screenshot of the window for selection of joint category.

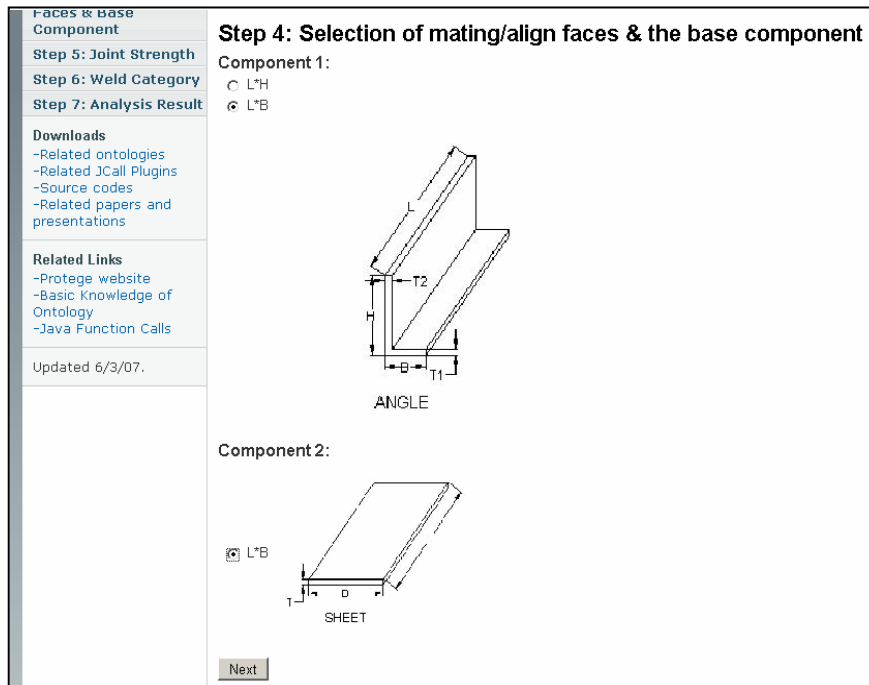

**Figure 4: Screenshot of Window for Joint Category Selection.**

#### **3.2.4. Step 4: Selection of mating/aligning faces and the base component.**

After confirming the weld category selection, the user selects the mating/aligning faces of the two components involved in the joint. Pictures of both components are displayed in the window. The user specifies the faces by selecting the thickness parameter of the geometry and selects the base component in the case of lap joints. Figure 5 shows a screenshot of the window for selection of mating/aligning faces and the base component.





**Figure 5: Screenshot of Window for Selection of Mating/Aligning Faces and Base Component.**

**3.2.5. Step 5: Specifying the joint strength.** In the next step, the user specifies the required joint strength by entering the joint strength value in MPa. Figure 6 shows a screenshot of the window for specifying joint strength.

Decision Support Tool for Friction Stir Processing	
Step 1: Welding Technique	Step 1: Welding Technique selection Result FSW
Step 2: Component Geometry & Material	Step 2: Selection of component geometry & material Component 1: Material: 6061 T-6, Geometry: Angle, (L=300, B=50, H=50, T1=5, T2=5) Component 2: Material: 6061 T-6, Geometry: Sheet, (L=300, B=50, T=5)
Step 3: Joint Category	Step 3: Selection of joint category Lap
Step 4: Mating/Align Faces & Base Component	Step 4: Selection of mating/align faces & the base component L*B and L*B
Step 5: Joint Strength	Step 5: Specifying the joint strength
Step 6: Weld Category	
Step 7: Analysis Result	
Downloads	<input type="text" value="235"/> MPa <input type="button" value="Next"/>
-Related ontologies	
-Related JCall Plugins	
-Source codes	
-Related papers and presentations	

**Figure 6: Screenshot of Window for Specifying Joint Strength.**

**3.2.6. Step 6: Specifying the weld category.** Finally, the user specifies the weld category. The options available for weld category are (a) continuous weld, (b) stitch weld, and (c) spot weld. Figure 7 shows a screenshot of the window for specifying the weld category.

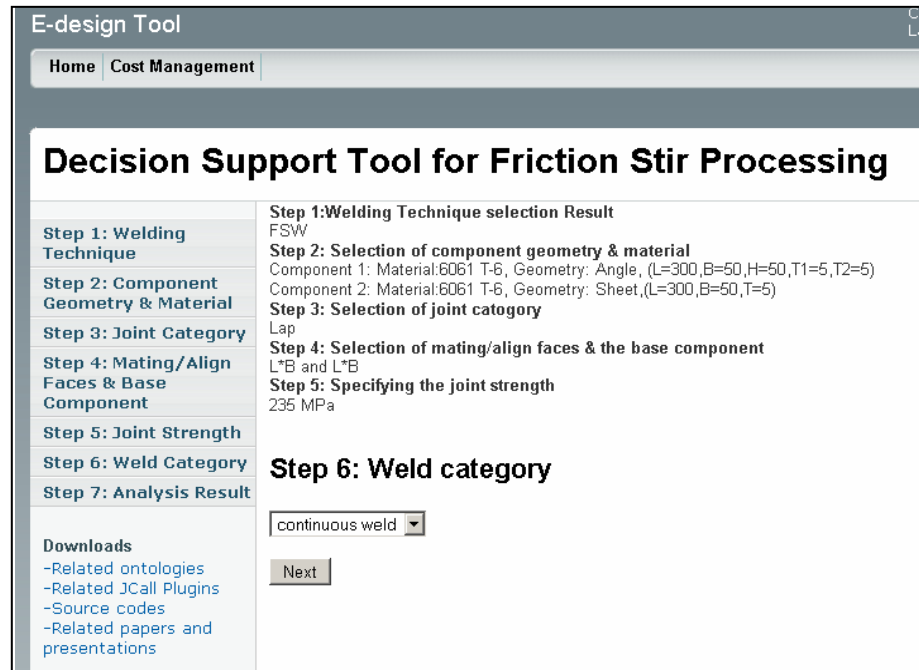

**Figure 7: Screenshot of Window for Specifying Weld Category.**

### 3.3 Outputs of the E-Design tool

After obtaining all user inputs, the output window is displayed. This window displays the following information:

- (a) Weld geometry parameters - number of spots, number of stitches with stitch length, and total weld length (depending on the weld category selected).
- (b) Tool details - tool material, tool pin type, shoulder profile, shoulder features, shoulder diameter, pin diameter(s), and pin height
- (c) Process parameters - tool tilt angle, plunge depth, plunge speed, tool rpm, tool travel rate, plunge force, dwell time
- (d) Machine Parameters - machine degrees of freedom, machine table size
- (d) Time required for welding
- (e) Ratio of joint strength to joint weight

The user can modify the output parameters generated by the E-Design tool. The rightmost column of the Analysis Result shown in figure 8 has the option to modify the output parameters.

Analysis Result		Want to
A) Length of weld	270 mm	increase decrease
B) Tool Material	Tool Steel	change
C) Shoulder Diameter	15 to 20 mm	increase decrease
D) Shoulder Profile / Face	Concave	change
E) Shoulder Features	Featureless	change
F) Tool Pin Type	Cylindrical	change
G) Pin Diameter	5 to 7 mm	increase decrease
H) Plunge Depth	4.75 mm	increase decrease
I) Pin Height	4.66 mm	increase decrease
J) Tool Tilt Angle	2 to 3 degrees	increase decrease
K) Plunge Speed	2 mm/sec	increase decrease
L) Tool RPM	800 to 1200	increase decrease
M) Tool IPM	5 to 10	increase decrease
N) Plunge Force	5 kN to 10 kN	increase decrease
O) Dwell Time	0 sec	increase decrease
P) Machine degrees of freedom	3	
Q) Machine Table Size	1st horz. dim=1100.0mm; 2nd horz. dim=600.0mm	increase decrease
R) Component Weights	Component 1 weight:384.75 grams; Component 2 weight:202.5 grams	increase decrease
S) Time required for welding	1.42 minutes	increase decrease
T) Strength to weight ratio	.40	increase decrease

**Figure 8: Screenshot of Output Window.**

This opens the *Design Suggestion* window displaying the dependency of the selected output parameter on other input/output parameters. Figure 9 shows the Design Suggestion window that opens when the user elects to change the tool material parameter. The input/output parameters that govern tool materials are displayed. The user can further click on the parameters in the second line to understand their relationship with other input/output parameters.



**Figure 9: Screenshot of Design Suggestion Window.**

#### **4. INPUT – OUTPUT RELATIONSHIPS**

The FSW database is a collection of input and output parameters resulting from the friction stir weld runs made at various research locations. Relationships between input and output parameters vary among weld runs. Weld runs were grouped to form dependency relationships between the input and output parameters. Table 3 provides a sample list of input parameters and the corresponding dependent output parameters.

**Table 3: Input and Output Parameters for the E-Design Tool**

<b>S.No.</b>	<b>Output Parameter</b>	<b>Input Parameter</b>
1	Total weld length	Length of component
2	Tool material	Component material
		Joint category
		Weld category
3	Tool shoulder diameter	Joint strength
		Component material
		Weld category
4	Tool shoulder profile	Weld category
		Joint category
		Component material
5	Tool shoulder features	Weld category
		Joint category
		Tool shoulder profile
6	Tool pin type	Weld category
		Joint category
		Component material
7	Tool pin diameter	Weld category
		Joint category
8	Plunge depth	Component thickness
		Joint strength
		Joint category
9	Tool pin height	Plunge depth
10	Tool tilt angle	Weld category
		Joint category
11	Tool RPM	Weld category
		Joint category
		Joint strength
12	Tool IPM	Joint strength
		Component material
13	Plunge force	Component material
14	Dwell time	Weld category
15	Tool IPM	Component geometry
		Weld geometry
16	Component weight	Component material
		Component dimensions
17	Welding time	Weld category
		Weld length
		Tool IPM
18	Strength-Weight ratio	Joint strength
		Component weights

## 5. RESULTS AND CONCLUSIONS

Presently, the FSW database is populated with 81 weld runs. The FSW database acts as a comprehensive repository, including joint specifications and the relevant process parameters. The weld runs were made on aluminum alloys of A319, A5083, A5754, A5052, A5182, A6016, A6063, A6061, A6082, A6061, A6005, and A6111. Grouping of the weld runs to obtain meaningful relationships between input and output parameters resulted in the generation of three sets of relationships. Hence, the E-Design Tool was programmed for three sets of input-output parameter relationships:

- (a) A6061 – Sheet to Angle – Butt Joint
- (b) A6111 – Sheet to Sheet – Lap Joint
- (c) A5182 – Sheet to Sheet – Butt Joint

The E-Design tool generates process parameters (outputs) for these three joints. Engineers, designers, and researchers can use the E-Design tool to select the process parameters for similar weld runs.



## 6. FUTURE WORK

Presently, the FSW database has many fields that are not populated because the articles and the experimental works consulted did not have complete data. These deficiencies impose limitations on the number of relationships that can be developed between the input and output parameters. Populating the FSW database with more complete data from various weld runs would permit development of a comprehensive repository.

More relationships between input and output parameters can be programmed into the E-Design tool. Moreover, its scope can be expanded to deal with joints between dissimilar metals. Tipaji [11] developed a cost calculator for the FSW technique. The outputs generated by the E-Design Tool could be used as inputs to this FSW cost calculator to determine the cost of the weld run. This functionality would help the user make an economic comparison between FSW joints and those made by other welding techniques.

## ACKNOWLEDGEMENTS

This work is supported in part by the National Science Foundation grant number EEC #0632803 and the Engineering Management & Systems Engineering department, Missouri University of Science and Technology. Any opinions, findings and conclusions or recommendations presented in this paper are those of the authors and do not necessarily reflect the views of the National Science Foundation or Engineering Management & Systems Engineering Department, Missouri University of Science and Technology.

The authors would like to thank Miss Kamini Gupta for providing FSW experimental data to populate the FSW database.

The authors would also like to thank Dr. Rajiv Mishra for his involvement in the discussions and his suggestions to build the FSW database and the E-Design tool.

The E-Design tool software was implemented by Xiaomeng Chang. Screenshots of the software interface (figure 2 - 9) are captured from this implemented software.

## REFERENCES

- [1] N. A. Rodriguez, E. Almanza, and C. J. Alvarez., *Study of friction stir welded A319 and A413 aluminum casting alloys*, Journal of Material Science, 2005, pp. 6-12.
- [2] J. W. Pew., *A Torque Based Weld Power Model for Friction Stir Welding*, Masters Thesis, Department of Mechanical Engineering, Brigham Young University, 2006.
- [3] K. J. Colligan, J. Xu, and J. R. Pickens., *Welding Tool and Process Parameters Effects in Friction Stir Welding of Aluminum Alloys*, Friction Stir Welding and Processing II, The Material Science Journal, Warrendale, PA, 2003, pp. 181-190.
- [4] A. P. Reynolds and W. Tang., *Alloy, Tool Geometry, and Process Parameter effects on Friction Stir Weld Energies and Resultant FSW Joint Properties*, Journal of Material Science, 2001, pp. 2-12.
- [5] A. L. Stahl, T. Yu-Pan, P. C. Lin, J. Pan, Z. Feng, and M. L. Santella., *Microstructure and Failure Mechanisms of Spot Friction Welding in Lap Shear Specimens of Aluminum 5754 Sheets*, SAE Technical Paper No: 2005-01-1256, Society of Automotive Engineering, Warrendale, PA, 2005.
- [6] T. Yu-Pan, A. Joaquin, D. E. Wilkosz, L. Reatherford, J. M. Nicholson, Z. Feng, and M. L. Santella., *Spot Friction Welding for Sheet Aluminum Joining*, Report No: 120980, Oak Ridge National Laboratory, Oak Ridge Tennessee, 2004, pp. 1-8.
- [7] L. Fartini and B. Zuccarello., *An Analysis of Through-Thickness Residual Stresses in Aluminum FSW butt joints*, International Journal of Machine Tools and Manufacture, 2005, pp. 3-14.
- [8] X. A. Guo, *A Study of Friction Stir Welding on 6061-T6 aluminum alloy*, PhD Dissertation, Mechanical Engineering Department, University of Texas at El Paso, 1999.
- [9] A. L. Stahl., *Experimental Measurements of Load Distributions on Friction Stir Weld Pin Tools*, Masters Thesis, Department of Mechanical Engineering, Brigham Young University, 2005, pp. 4-11.
- [10] [www.en.wikipedia.org](http://www.en.wikipedia.org), last visited on March 20<sup>th</sup>, 2008.
- [11] P. K. Tipaji., *E-Design Tool for Friction Stir Welding and Processing: Cost Estimation Tool*, Masters Thesis, Manufacturing Engineering Department, Missouri University of Science and Technology, 2007.

## VITA

Harish Bagaitkar was born on 11 September, 1980, in Nashik, India. He received his Bachelor of Mechanical Engineering from the University of Pune, Pune, India in the summer of 2002. During the pursuit of his master's degree, the author has had the opportunity to publish two conference papers, listed below:

**Paper-I:** Design for Manufacturing (DFM) methodology to implement Frictions Stir Welding (FSW) for automobile chassis fabrication. (ASME 2008 International Design Engineering Technical Conferences & Computers and Information in Engineering Conference, New York, USA)

**Paper-II:** E-Design Tool for Friction Stir Welding (FSW). (ASME 2008 International Conference on Manufacturing Science & Engineering, Illinois, USA)