

# MIMO-OFDMA Subcarrier Mapping Improvement by using Quarter ICI-SC with STFBC Technique

Hanis Adiba Mohamad, Azlina Idris, Kaharudin Dimiyati  
*Wireless Communication Technology Group (WiCoT),  
 Advanced Computing and Communication Communities of Research,  
 Faculty of Electrical Engineering,  
 Universiti Teknologi MARA (UiTM), Shah Alam, Malaysia.  
 adibahanis@yahoo.com*

**Abstract**—Many wireless communication systems rely on Orthogonal Frequency Division Multiple Access (OFDMA) to guarantee reliable transmission and better performance. However, the orthogonality of the subcarriers has been destroyed by frequency offset (FO) and thus leads to inter-carrier interference (ICI) which reduces the system performance. In order to overcome this problem, quarter ICI self-cancellation (ICI-SC) subcarrier mapping scheme using data allocation in space-time-frequency block codes (STFBC) for MIMO-OFDMA system is proposed. The technique is then evaluated through Pairwise Error Probability (PEP) and Bit Error Rate (BER) performance. From the results, proposed quarter ICI-SC subcarrier mapping scheme technique with STFBC shows the best result for MIMO-OFDMA system.

**Index Terms**—Pairwise Error Probability (PEP); Inter-Carrier Interference Self-Cancellation (ICI-SC); Space Time Frequency Block Codes (STFBC); Orthogonal Frequency Division Multiple Access (OFDMA).

## I. INTRODUCTION

Nowadays, extraordinary data rates with high quality and mobility are the keys to fulfill the demand for wireless communication rapid development. Orthogonal Frequency Division Multiplexing (OFDM) seems to be attentive and teeming communication system for numerous of wireless communication technology application for example wireless local area networks and next generation mobile cellular wireless system [1].

Currently, there is a strong interest in extending the OFDM concept to multi-user communication scenarios which is Orthogonal Frequency Division Multiple Access (OFDMA) technology. It is a result from combination of OFDM with frequency division multiple access (FDMA) protocol. OFDMA mode attempts to optimize mobile access by many simultaneous users through breaking a signal into sub-channels. It mandates orthogonality among sub-channels and a special case of multi-carrier modulation which saves up the use of spectrum with high data rate services and considered as a good choice due to its ability to overcome multipath fading [2].

Many broadband wireless networks now have included Multiple Input Multiple Output (MIMO) option in their protocols. This is because extraordinary data rates can be achieved by using multiple antenna at both ends of wireless link [3]. In principle, OFDMA and MIMO combination techniques can offer the benefits of simplicity, high performance system [4] and exploitation of the multipath diversity that increases the achievable rate and enhances link

reliability [5].

The proposed method is to test the diversity performance of this system by using the Alamouti code technique which is easier compared to the others. Basically, there are two diversity order system when applying this technique in OFDMA system, the Space-Time Block Codes (STBC) and Space-Frequency Block Codes (SFBC). A combination of both is Space-Time-Frequency Block Codes (STFBC) and it offers spatial, temporal and frequency diversity MIMO channels which distributes symbols along transmit antennas, time slots and at different frequencies [6][7]. This STFBC may contain OFDMA symbols which can improve diversity order [8].

Even OFDMA has a lot of advantages, but there are still some disadvantages exist in this system. Based on the orthogonality among subcarrier signals, OFDMA is vulnerable to synchronization errors and results in performance degradation. One of synchronization errors in OFDMA signals is carrier frequency offset (CFO) which leads to intercarrier interference (ICI). For many years, researchers have developed various methods to reduce ICI in OFDMA systems and can be categorized as frequency-domain equalization [9], time-domain windowing [10], self-cancellation (SC) scheme [11], estimation and compensation technique [12] and Doppler diversity etc.

In SC technique, simple conjugated data allocation of  $(X_k, X_{k+1} = -X_k^*)$  [13] is used to increase the PEP performance. In this paper, the problem of ICI is reduced by implementing ICI-SC technique in which STFBC encoder will be affixed into the system. The transmitted data will be mapped using a subcarrier mapping technique in a phase shift of  $\pi/2$  with a counter sign onto the subcarriers, regardless of adjacent or non-adjacent subcarriers [11]. From the previous research [14], it is hard to effectively obtain frequency diversity gain when the distance between subcarriers and repeated subcarriers is too far or too short.

In this paper, ICI caused by FO is eliminated by applying STFBC with quarter ICI-SC subcarrier mapping technique. It is assumed that an ideal distance among subcarriers and repeated subcarriers of STFBC and ICI-SC technique can eliminate ICI and as a result maximum diversity with efficient bandwidth can be seized. The assumption can be proved by analyzing the result of PEP and BER performance in presence of FO using proposed quarter subcarrier mapping compared with other methods for instance adjacent, symmetric and median to determine whether this suggested method would offer a better performance for MIMO-OFDMA system.

## II. SYSTEM MODEL

The transmitter and receiver architecture of new ICI-SC subcarrier mapping scheme is shown in Figure 1. The MIMO-OFDMA system is using  $m$  transmit antennas and  $n$  receive antennas. Between each pair of transmit and receive antennas, six paths COST207 (Jakes Model) of the L-path quasi static Rayleigh fading channel model is applied.  $K$  is number of subcarriers in the OFDM modulators. Frequency selective fading channels between each pair of transmit and receive antennas have  $L_p$  independent delay paths and same power delay profile. The MIMO channel is assumed to be constant over each OFDMA block period, but it may vary from one OFDMA block to another.

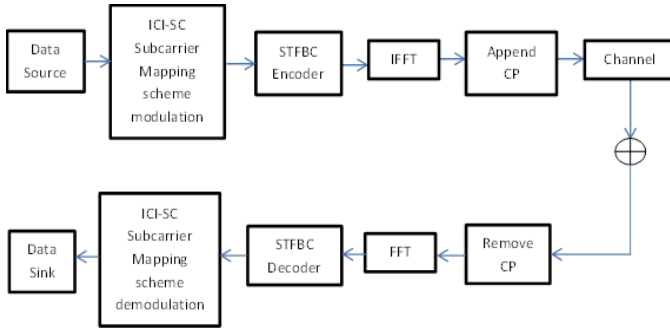

Figure 1: STFBC for MIMO-OFDMA with subcarrier mapping scheme (ICI-SC technique) model

At the transmitter, data input are random data produced by MATLAB command language. The system parameters used are Mobile WiMAX wireless communication standards for OFDMA technology as shown in Figure 2.

System bandwidth(MHz)	1.25	2.5	5	10	20
Sampling frequency (MHz)	1.4	2.8	5.6	11.2	22.4
FFT size	128	256	512	1024	2048
Subcarrier spacing (kHz)	10.94				
OFDM symbol duration ( $\mu$ s)	102.86				
Useful symbol time ( $\mu$ s)	91.43				
Cyclic prefix ( $\mu$ s)	11.43				

Figure 2: Mobile WiMAX system parameter

At the receiver, the  $k_{th}$  subcarriers are divided into segments respectively in MIMO-OFDMA and the received signal vector can be shown as follows:

$$Y_n(k) = \sum_{m=1}^M X_m(k) H_{m,n}(k) S_{m,n}(0) + z_n(k) \quad (1)$$

- $Y_n(k)$  = received signal at the receiver
- $X_m(k)$  = the transmitted signal
- $H_{m,n}(k)$  = channel impulse response
- $S_{m,n}(0)$  = desired  $k_{th}$  carrier component
- $z_n(k)$  = complex Gaussian thermal noise

where the basic STFBC mapping codeword can be expressed as:

$$X_m = \begin{bmatrix} X_1(0) \dots\dots\dots X_2(0) \\ X_1(0) \dots\dots\dots -X_2(0) \\ X_1(N-1) \dots\dots\dots X_2(N-1) \\ X_1(N-1) \dots\dots\dots -X_2(N-1) \end{bmatrix} \quad (2)$$

ICI-SC technique was applied to STFBC using the subcarrier mapping technique suggested by [15] with a repeating scheme where  $r = 2$ . This indicates that the symbols are being repeated twice but the repeated symbols are signed-reversed. Nevertheless, in this paper, the PEP estimation of MIMO-OFDMA is done by using quarter subcarrier mapping technique. The STFBC codeword has the form of:

$$\begin{bmatrix} X_1(0) & \dots & \dots & X_2(0) \\ -X_2(\frac{N}{4} - \frac{N}{8}) & \dots & \dots & -X_2(\frac{N}{4} - \frac{N}{8}) \\ \dots & \dots & \dots & \dots \\ X_1(\frac{N}{4} - \frac{N}{8}) & \dots & \dots & X_2(\frac{N}{4} - \frac{N}{8}) \\ -X_1(0) & \dots & \dots & -X_2(0) \\ \dots & \dots & \dots & \dots \\ X_1(\frac{N}{8} + 1) & \dots & \dots & X_2(\frac{N}{8} + 1) \\ -X_1(\frac{N}{4}) & \dots & \dots & -X_2(\frac{N}{4}) \\ \vdots & \vdots & \vdots & \vdots \\ \dots & \dots & \dots & \dots \\ X_1(\frac{N}{4} + 1) & \dots & \dots & X_2(\frac{N}{4} + 1) \\ -X_1(\frac{N}{4} + \frac{N}{8}) & \dots & \dots & -X_2(\frac{N}{4} + \frac{N}{8}) \\ \dots & \dots & \dots & \dots \\ \dots & \dots & \dots & \dots \\ X_1(\frac{N}{4} + \frac{N}{8} + 1) & \dots & \dots & X_2(\frac{N}{4} + \frac{N}{8} + 1) \\ -X_1(\frac{N}{4} + \frac{N}{4}) & \dots & \dots & -X_2(\frac{N}{4} + \frac{N}{4}) \\ \dots & \dots & \dots & \dots \end{bmatrix} \quad (3)$$

ICI-SC technique proposed by [16] is exerted into the system whereby interference cancellation modulation (ICM) is applied to STFBC encoder. In this paper, quarter method will be evaluated using PEP performance.

The ICI coefficient is:

$$S_{m,n}(k) = \frac{\sin(\pi(k + \epsilon_{m,n}))}{K \sin(\frac{\pi}{K}(k + \epsilon_{m,n}))} \exp \left[ j\pi \left( 1 - \frac{1}{K} \right) (k + \epsilon_{m,n}) \right] \quad (4)$$

Note that the  $S_{m,n}$  is a constant with respect to subcarrier index  $k = 0$ , where  $\epsilon_{m,n}$  is normalized frequency offset (NFO).

$$S_{m,n}(0) = \frac{\sin(\pi \epsilon_{m,n})}{K \sin(\frac{\pi}{K} \epsilon_{m,n})} \cdot \exp(j\pi \left( 1 - \frac{1}{K} \right) \epsilon_{m,n}) \quad (5)$$

In order to get better system performance, it is crucial to get lower PEP value for lower noise and interference. As the value of  $\epsilon_{m,n}$  in Equation (4) increases, ICI will also increase. As a result, ICI causes increasing in PEP and decreasing of SNR performance.

## III. DESIGN CRITERIA OF PEP

The method of evaluating the PEP performance is further explained as follows:

### A. Pair-wise error probability (PEP)

The union bound is known as the most fundamental for

computing the error probability in digital communication. Union bound can be defined as the probability that at least one of the detected symbol (error) is no greater than the sum of the probabilities of the transmitting symbol. Thus, the Equation (6) below shows the probability to detect the receive signal vector or symbol containing error when another transmit symbol is coming. In brief,  $D$  can be defined as the transmit symbol while  $\bar{D}$  is the decoded symbol (error). The minimum error will result in a lower value of PEP, thus a better system performance [9].

$$P(D \rightarrow \bar{D}) \leq \mathcal{A} \left( \frac{2\Gamma N - 1}{\Gamma N} \right) \left( \prod_{i=1}^{\Gamma} \lambda_i \right)^{-N} \xi^{-\Gamma N} \quad (6)$$

where:  $D$  = Transmit codeword  
 $\bar{D}$  = Decoded codeword with error  
 $\ell$  = Loss  
 $\Pi$  = Product criterion  
 $\lambda_i$  = Non-zero Eigen value  
 $N$  = Number of subcarriers  
 $\Gamma$  = Rank ( $\Delta D.R$ )

The transmitting data will undergo quarter mapping method and mapped into the STF block codes, where the  $X_m$  contains the data symbols as seen in Equation (6) are actually in the rank. The  $\lambda_i$  non-zero Eigen value of rank.  $P(D \rightarrow \bar{D})$  is where the possibility of decoded symbol containing error or faulty.

The more minimum of upper bound of PEP, the system performance is better. Consequently, several points are taken into consideration as below:-

- Product criterion: the minimum value of the product  $\prod \lambda_i$ , over all pairs of  $D$  and  $\bar{D}$  should also be maximized
- Diversity rank criterion: the minimum rank of ( $\Delta D.R$ ) over all pairs of different code words,  $D$  and  $\bar{D}$  should be large as possible.

**B. Space Time Frequency Block Coding Schemes**

A space time frequency is a combination of ST and SF code in order to get the spatial, frequency and time diversity. STF diversity is beneficial since it can allow many similar symbols to be transmitted through the multiple antennas at different time and frequency. Therefore, a maximum diversity order can be seized by using this spatial multiplexing and diversity technique. The example of coding in STFBC method as suggested in [12] is shown in Table 2.

Table 1  
Coding in STFBC method

Antenna and time slot frequency	Ant 1 (T1)	Ant 2 (T2)
f1	$X_k$	$X_{k+1}$
f2	$-X_{k+1}$	$X_k^*$

**IV. RESULT AND DISCUSSION**

The proposed STFBC design methods were simulated using Matlab programming with system parameter in Table 3. The system uses 72 subcarriers for STFBC codes design methods which are adjacent, symmetric, median and quarter ICI-SC subcarrier mapping scheme. The results are compared to analyze the best performance.

Figure 4 shows the simulation results of PEP performance by using different types of ICI-SC subcarrier mapping

scheme with STFBC in MIMO-OFDMA system with 5% frequency offset. The PEP curves act as SNR and NFO functions. At PEP =  $1 \times 10^{-4}$ , the lowest SNR value is produced by quarter subcarrier mapping technique which is 16.5dB followed by median 17dB, symmetry 18dB and adjacent 19dB. It shows that quarter subcarrier mapping technique in Equation (3) has the best PEP performance compared to adjacent technique with 13.16% of improvement. This is because quarter subcarrier mapping provides the ideal (not too long or too short) distance between subcarriers compared to the other subcarrier mapping methods and as a result produces least ICI. Adjacent method has very short distance between subcarriers otherwise symmetric method has very long distance between subcarriers. Refer to Equation (7), the minimum rank of all pairs of codewords,  $D$ , so  $\bar{D}$  should be larger as possible so that maximum diversity is achieved. It is strongly suggested that this approached method is reliable to produce the lowest noise and interference in the presence of 5% FO.

Figure 5 shows simulation results of BER performance for different types of STFBC ICI-SC subcarrier mapping scheme of MIMO OFDMA system. Quarter subcarrier mapping with 8.4 dB has the best BER performance as it produces less interference system, as well as reducing the ICI with maximum diversity order system. The BER performances of median, symmetric and adjacent scheme are 8.7 dB, 9.8 dB and 10.2 dB respectively. Overall results show that quarter subcarrier signal remapping can achieve the highest diversity order and maximum frequency diversity in the system. The BER performance is increased by 17.65%.

**V. CONCLUSION**

In this paper, quarter ICI-SC subcarrier mapping scheme is proposed to cancel the effect of ICI caused by frequency offset in OFDMA system and equations of ICI-SC quarter subcarrier mapping have been derived. Based on the system with PEP and BER, the lowest value of SNR creates better system performance. From the results, it is shown that PEP and BER performance evaluation are the best when using proposed quarter subcarrier mapping method as there is percentage of improvement compared to other previous method. To sum up, quarter subcarrier mapping can be applied to achieve maximum frequency diversity gain with optimal distance, lower SNR and less noise in present of FO.

Table 2  
Simulation parameter

Parameters	Values
IFFT size	128
Mapping scheme	64-QAM
No of OFDMA symbols	100
Bits per OFDMA symbols	$N * \log_2(M)$
Number of carriers	72
Channel	Multipath Rayleigh Fading
Frequency offset	0.05

Table 3  
Simulation result of different subcarrier mapping methods with NFO = 5% at PEP =  $1 \times 10^{-4}$

Method	NFO= 5 %
Adjacent	19dB
Symmetry	18dB
Median	17dB
Quarter	16.5dB

Table 4  
Simulation result for different methods with NFO = 5% at  
BER =  $3 \times 10^{-2}$

Method	NFO= 5 %
Adjacent	10.2dB
Symmetry	9.8dB
Median	8.7dB
Quarter	8.4dB

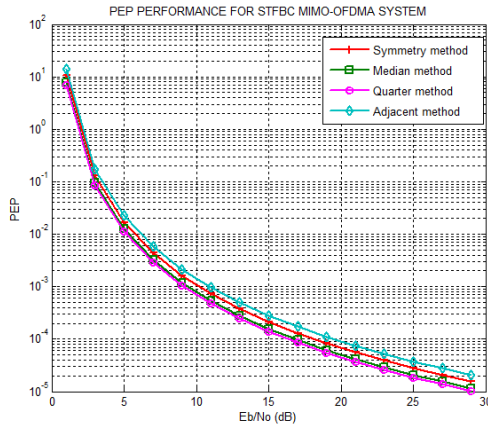

Figure 3: PEP performance of different subcarrier mapping scheme with 5% frequency offsets

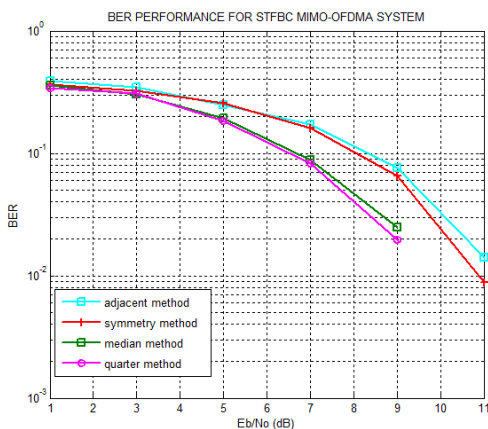

Figure 4: BER performance of different subcarrier mapping scheme with 5% frequency offsets

ACKNOWLEDGMENT

The author would like to thank Fakulti Kejuruteraan Elektrik UiTM Shah Alam.

REFERENCES

- [1] Bolcskei H., "MIMO-OFDM WIRELESS SYSTEMS: Basics, Perspectives, and Challenges," *IEEE Wirel. Commun.*, pp. 31–37, 2006.
- [2] Gilberto B. "OFDMA Vs . SC-FDMA : Performance Comparison In Local Area IMT-A Scenarios," *IEEE Wirel. Commun.*, no. October, pp. 64–72, 2008.
- [3] Idris A. and Dimiyati K., "CIR and BER Performance of STFBC in MIMO OFDM System," *Aust. J. Basic Appl. Sci.*, vol. 5, no. 12, pp. 3179–3187, 2011.
- [4] Wei Chang X.-G. X., "Space -Time / Frequency Coding for Mimo-Ofdm in Next Generation Broadband Wireless Systems," no. June, pp. 32–43, 2007.
- [5] J.Love D., "Diversity Performance of Precoded Orthogonal Space-Time Block Codes Using Limited Feedback," *IEEE Commun. Lett.*, vol. 8, no. 5, pp. 305–307, 2004.
- [6] B. Gupta and D. S. Saini, "A low complexity decoding scheme of STFBC MIMO-OFDM system," *2012 Wirel. Adv. WiAd.*, vol. 1, pp. 176–180, 2012.
- [7] W. Zhang, X. G. Xia, and K. Ben Letaief, "Space-time/frequency coding for MIMO-OFDM in next generation broadband wireless systems," *IEEE Wirel. Commun.*, vol. 14, no. 3, pp. 32–43, 2007.
- [8] Uysal M., Al-Dhahir N., and Georgiades C. N., "A space-time block-coded OFDM scheme for unknown frequency-selective fading channels," *IEEE Commun. Lett.*, vol. 5, no. 10, pp. 393–395, 2001.
- [9] Ahn H. S., J. and Lee. "Frequency Domain Equalisation of Ofdm Signals Over Frequency Nonselective Rayleigh Fading Channels," *Electron. Lett.*, vol. 29, no. 16, pp. 1–2, 1993.
- [10] Gudmundson M. and Anderson P.-O., "Adjacent channel interference in an OFDM system," *Proc. Veh. Technol. Conf. - VTC.* vol. 2, pp. 918–922, 1996.
- [11] Zhao Y. and Häggman S. G., "Intercarrier interference self-cancellation scheme for OFDM mobile communication systems," *IEEE Trans. Commun.*, vol. 49, no. 7, pp. 1185–1191, 2001.
- [12] Moose P. H. and Mqose P. H., "A technique for orthogonal frequency division multiplexing frequency offset correction," *IEEE Trans. Commun.*, vol. 42, no. 10, pp. 2908–2914, 1994.
- [13] Dao D. N. and Tellambura C., "Intercarrier Interference Self-Cancellation Space-Frequency Codes for MIMO-OFDM," vol. 54, no. 5, pp. 1729–1738, 2005.
- [14] Sathananthan K., Rajatheva R. M. a. P., and Slimane S. B., "Analysis of OFDM in the presence of frequency offset and a method\nto reduce performance degradation," *Globecom '00 - IEEE. Glob. Telecommun. Conf. Conf. Rec. (Cat. No.00CH37137)*, vol. 1, no. 3, pp. 72–76, 2000.
- [15] Idris A. and Dimiyati K., "Performance Evaluation of Intercarrier Interference Self-Cancellation Schemes for Space Time Frequency Block Codes MIMO-OFDM system," pp. 1–5, 2008.
- [16] Dimiyati K. and Syed-yusof S. K., "Space Time Frequency Block Codes for MIMO-OFDM system using Intercarrier Interference Self-Cancellation Schemes," pp. 116–121, 2008.