

# FBG-Based Filtering Optical Clock and Data Recovery Enhancement for Optical Access Networks

S.K. Idris, M.S. Sharuddin, H. Haroon, H. Abdul Razak, F. Salehuddin and A.S. Mohd Zain  
*Faculty of Electronic & Computer Engineering, Universiti Teknikal Malaysia Melaka (UTeM).  
 sitikhadijah@utem.edu.my*

**Abstract**— Data transmission using optical fiber can be affected by nonlinear effects, dispersion, and crosstalk. These effects are causing the optical signal to be degraded. Optical clock and data recovery are necessary to synchronize and regenerate the affected signal and consequently achieving a good BER value. In this paper, a system with optical clock and data recovery function using FBG and FP-FBG filter technique is tested and analyzed using OptiSystem software. Eye diagram for both configurations is observed. Some parameters are also being manipulated such as the data rate and transmission distance to compare both FBG filtering effect. Clock data recovery signal with FBG filtering shows better performance compare to FP-FBG filtering at 10 Gbps.

**Index Terms**— Fiber Bragg Grating (FBG); Fabry Perot-Fiber Bragg Grating (FP-FBG); Optical Access Network; Optical Clock and Data Recovery; OptiSystem.

## I. INTRODUCTION

Extending the reach of optical transmissions at higher bit rates becomes a major challenge as the transmission impairments such as linear and nonlinear effects, scattering losses etc. will generally affect optical transmission and decrease the quality of the optical signal along the propagation path. Transmitting data at increased data rates over long transmission distance also will incur timing jitter. This problem can be reduced electrically or optically. For electrical domain, a degraded optical signal is transformed into an electrical signal to alleviate these transmission impairment utilizing Digital Signal Processing (DSP), dispersion compensating fiber (DCF), fiber Bragg and others [1-4].

The effect of the timing jitter can be mitigated by proper synchronization and self-synchronization using all-optical clock recovery from the received data is the preferred method for establishing data synchronization [5]. Optical clock and data recovery (CDR) method are popular when it comes to optical system design as it can increase the distance and data rate of the data transmission. This transmission distance is expanded by synchronizing and regenerate the data/signal along the optical transmission so that the signal at the receiving end is less noise resulting in achieving acceptable bit error rate (BER). Several methods are used to implement the CDR such as quantum dash lasers [6], self-pulsating lasers [7] and passive filtering techniques [8-9].

Among the CDR implementation, the simplest methods are to extract the clock tone from the signal using a passive filter. Various kind of filters such as narrowband-pass

filters, tunable Fabry-Perot (FP) filters and Fiber Bragg Grating (FBG) have been used for this purpose [10-12]. All-optical clock recovery using an FBG based phase-only optical filter has a limited extinction ratio of the filter and in contrast, all-fiber Fabry Perot filter is capable of providing higher extinction ratio in a compact all-fiber device [12].

FBG optical fiber reflects a particular light wavelength and allows the transmission of another light wavelength. This can be realized by creating a periodic variation in the refractive index of the fiber core that produces a wavelength-specific dielectric mirror [13]. Thus, FBG can be used as an optical filter to block any desired wavelengths.

Figure 1 shows the cross-sectional of FBG with the inside components. There are three layers with refractive index  $n_1$ ,  $n_2$  and  $n_3$  that represent fiber core, cladding and buffer respectively. The FBG is designed so it reflects certain wavelengths of light and allows the other wavelengths [14]. FBG as an optical filter will reject a certain wavelength and reflects it.

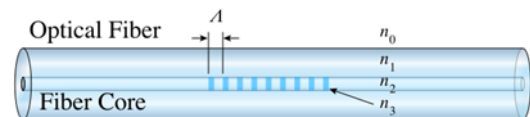

Figure 1: Fiber Bragg Grating.

The reflected wavelength,  $\lambda_B$  can be obtained using relationship in Eq. 1

$$\lambda_B = 2n_{eff}\Lambda \quad (1)$$

where  $n_{eff}$  is the effective refractive index of the fiber core and  $\Lambda$  is the spacing between the gratings, known as the grating period. The bandwidth of the Bragg filter  $\Delta\lambda$  is defined as the spacing between the first 2 nulls around the reflected wavelength  $\lambda_B$  and given by:

$$\Delta\lambda = \frac{2\lambda_B\eta\delta n_0}{\pi} \quad (2)$$

where  $\delta n_0 = n_2 - n_3$ , is the variation in the refractive index and  $\eta$  is the power fraction in the fiber core.

Fabry-Perot fiber Bragg Grating (FP-FBG) is a combination of two filters. For the structure, FP-FBG is fabricated as a pair of identical FBGs separated by a small distance. Two identical reflectors with a small separation together constitute an FP cavity. Hence FP-FBG combines the functionalities of a narrowband filter and FP filter. The

use of an FP-FBG provides a compact solution for CDR [12].

When designing the data transmission system, several important parameters need to be considered. Dispersion and attenuation are the main problems occur which generally can be overcome using Erbium doped amplifiers (EDFA) and DCF respectively. EDFA is used due to its low insertion loss and high gain and DCF is installed to compensate for fiber dispersion.

Noise influence makes a change in the rate of the transmitted bit. In telecommunication transmission, the BER is the percentage of bits that have errors relative to the total number of bits received in transmission [15]. The greatest limit of a reliable information transmission system is not by keeping the BER at a great of low degree, however by pushing the data rate to a level where some fair piece error rate which is about  $10^{-12}$  to  $10^{-9}$ . A practically error-free transmission, in any case, can be accomplished by recognizing and adjusting a large portion of the rest of the bit errors. For example, by using check sums, identified bit errors can be fixed by resending the affected data packages [16].

In this paper, the CDR system is designed and implemented in Optisystem software. The performance of the system with FBG filtering and FP-FBG filtering is tested for different transmission distances and transmission data rates. Eye diagram for both passive filtering technique is observed. Finally, a study of the CDR performance is presented in the context of the BER versus the transmission data rate and the transmission distance.

## II. SYSTEM MODEL

The FBG function to reflect a particular wavelength of light and transmits all the others. The designed optical CDR architecture using FBG filter is shown in Figure 2. The system comprises two optical sources (CW Laser) with different wavelengths,  $\lambda_1$  at 1530nm and  $\lambda_2$  at 1550 nm. Both optical sources are forwarded into Mach Zehnder

Modulator (MZM), where the intensity modulates the laser source according to the electrical signal. The first laser beam is modulated by the clock information (at 1530 nm) and the second laser source is modulated by the electric signal which is generated by a pseudo-random bit generator (at 1550 nm). WDM multiplexing is used to multiplex the modulated optical signals using WDM-MUX. After that, the signal is injected into a fiber cable. In this system model, the length of fiber cable ranging from 5 km to 150 km.

As soon the signal reaches the receiver, it is then split into two branches using a 50:50 power splitter. From the first branch, the effect of the signal without optical CDR can be monitored. Whereas from the second branch, the receiver with optical CDR can be evaluated. For the receiver without optical CDR, the signal is sent directly to DCF, PD and LPF before the BER is obtained.

In this optical CDR configuration, FBG filter is used in the architecture instead of distributed Bragg reflector laser (DBRL) due to its simplicity [14], [17]. Based on FBG filtering model as depicted in box (a), at the receiver, the signal is sent to CDR loop which consists of DCF, two FBG filters, circulator, attenuator, SOA (amplifier) and OBPF before the signal is directed into PD, LPF and then finally to obtain the BER data. The circulator is a three-port device that allows light to travel in only one direction. SOA helps to amplify the recovered signal. The photodetector is used to convert optical power to electrical current while the optical attenuator is used to decrease the power level of an optical signal.

The transmission signal is then tested on CDR with FP-FBG filtering. FP filter and the isolator is connected between the circulator and the first FBG. The isolator is used to ensure the signal is transmitted in one direction. The system model without CDR and with CDR using FBG filtering and FP-FBG filtering is simulate using Optisystem and the eye diagram for each case is observed. The example of the circuit construction for simulation is shown in Figure 3.

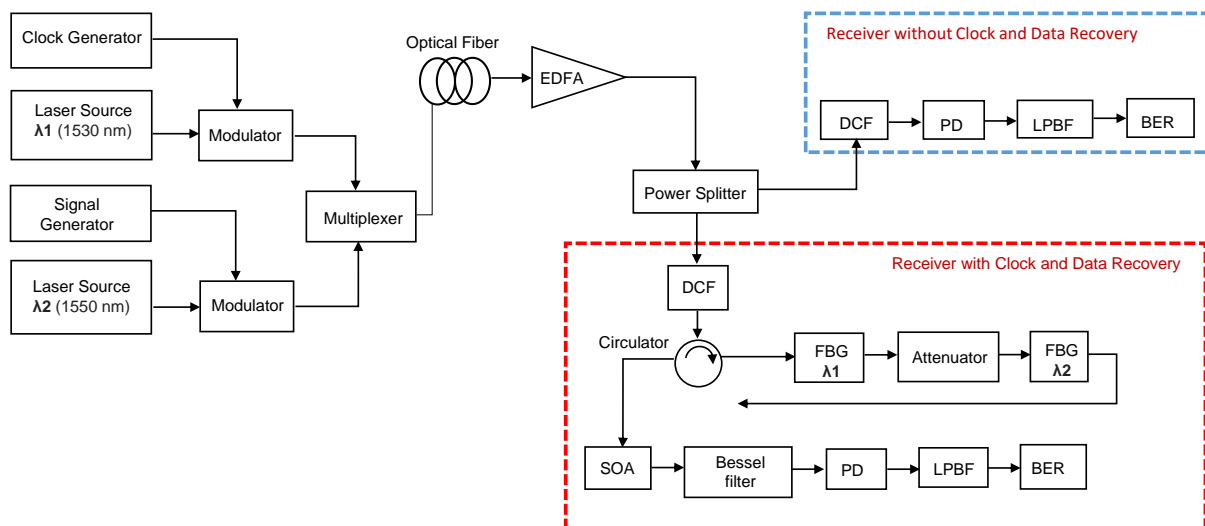

Figure 2: Model of the optical transmission system without CDR and with CDR using FBG filtering.

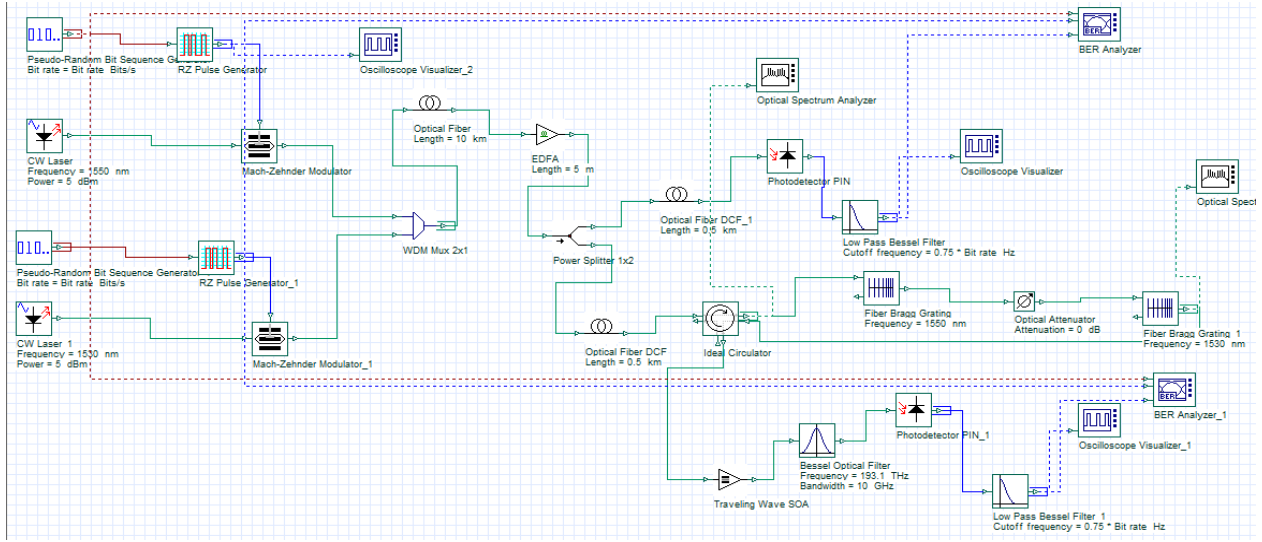

Figure 3: Example of a circuit for simulation on Optisystem software

Certain importance key parameters are set in order to see the FBG and FP-FBG filtering effect on the circuit with CDR. Table 1 shows the value of parameters used in the system.

Table 1  
System Parameters

Parameters	Value
CW Laser power	5 dBm
EDFA	5 m and 25 m
Data rate	1 to 10 Gb/s
Fiber length	5 km to 100 km
DCF Length	0.5 km
DCF Dispersion	-80 ps/nm/km
DCF Dispersion Slope	-0.5 ps/nm <sup>2</sup> /km
Fiber Bragg Grating frequency	1550 nm and 1553 nm
SOA injection current	0.15 A

### III. RESULT AND DISCUSSION

From the simulation using Optisystem software, the eye diagram for transmission without CDR and with self-clock CDR for both filtering using FBG and FP-FBG can be the monitor. For the optimum signal transmission, EDFA length is set to be 20 m. Good eye diagram was obtained at 30 km with a data rate of 10 Gbps as depicted in Figure 4.

Figure 4(a) shows the eye diagram for transmission without CDR. The eye is clean, big and wide as it is direct transmission. Figure 4(b) is the CDR eye diagram with FBG-based filtering and figure 4(c) is the eye diagram with FP-FBG filtering. The eye for FBG filtering CDR is acceptable since it is big and clear. However, for FP-FBG the eye is getting messy with unclear eye diagram.

The following analysis is about the transmission distance and transmission bit rate.

#### A. Transmission distance

Transmission distance is set to be between 5 km to 150 km and the transmission rate is fixed to 10 Gbps. The BER is obtained for CDR circuit with FBG and FP-FBG filtering. Figure 5 shows the graph for BER in log versus the distance in km for FBG and FP-FBG filtering CDR. Over the distance, BER for FP-FBG filtering does not shows any improvement. Even at a shorter distance the BER achieved

is at  $10^{-2}$ . The effect is in agreement to the unclean eye diagram shown in Figure 4(c). However, CDR circuit with FBG filtering shows convincing transmitted signal

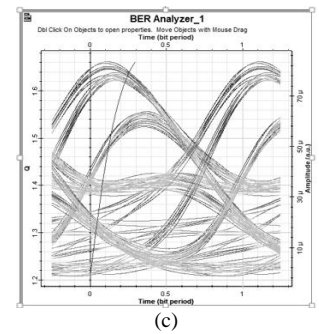
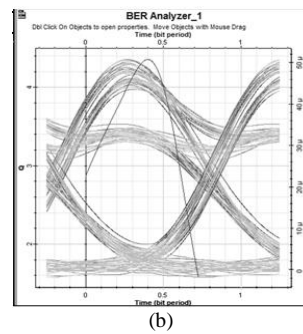
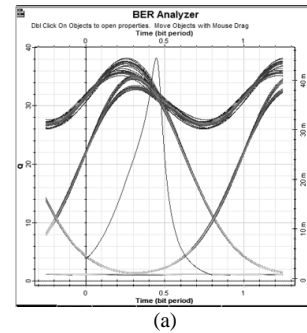

Figure 4: Eye diagram for 30 km with 20 m EDFA (a) without CDR, (b) FBG filtering with CDR and (c) FP-FBG filtering with CDR

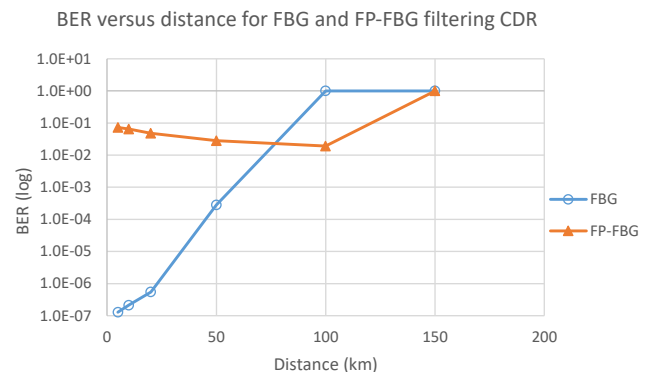

Figure 5: The graph for BER versus distance in km for CDR circuit with FBG and FP-FBG filtering

At a shorter distance, the transmission signal is stable with BER  $10^{-9}$  and this is in-line with the eye diagram depicted earlier in Figure 4(b). As predicted, when the distance increased, the signal starts to deteriorate hence affected the BER and the eye diagram. At 150 km, the error is detected as the BER value obtained is 1 for both FBG and FP-FBG filtering.

**B. Transmission rate**

For the transmission rate analysis, the system is tested with varies data rate between 2.5 Gbps to 40 Gbps. The transmission distance is maintained at 30 km. At this fixed distance of 30 km, CDR circuit with both FBG and FP-FBG filtering shows approximately the same BER performance. At 10 Gbps, FBG filtering achieved its optimum performance with good BER compared to FP-FBG filtering which achieved its optimum BER at the slightly lower data rate. At 40 Gbps error is occurs for both filtering technique since BER values obtained is 1 as listed in Table 2.

Table 2  
BER for varies transmission rate

Transmission rate (Gb/s)	BER value	
	FBG	FP-FBG
2.5	3.924903E-25	1.42862E-34
10	3.32008E-06	0.043567
40	1	1

Figure 6 shows the relationship between BER to the varied data rate as discussed. Based on part B, the results show that as the data rate increases, the BER value increases exponentially for both FBG and FP-FBG filtering until reaching saturated at 40 Gbps.

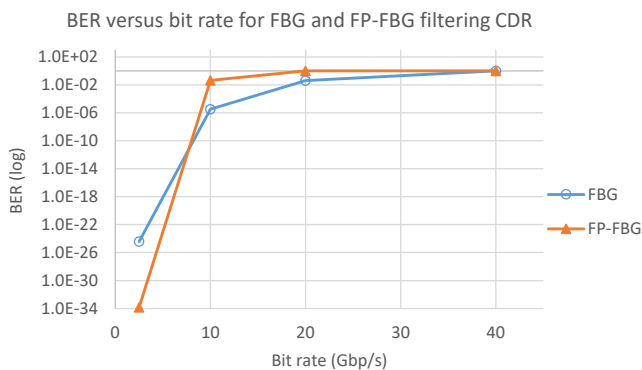

Figure 6: The graph for BER versus data rate in Gbps for CDR circuit with FBG and FP-FBG filtering

**IV. CONCLUSION**

In this work, two type of FBG filter is used in the optical transmission system for optical clock and data recovery. The first filter is FBG and the second filter is FP-FBG. Both filters are compared in terms of eye diagram and BER for different distance and data rate. FBG filter shows better performance to the CDR signal from a big, wide and clean eye diagram compare to FP-FBG filter. The CDR from FBG filtering is showing a strength and stable signal at BER  $10^{-7}$  for the first 20 km and the signal degraded as the distance increased. However, the signal from FP-FBG is weak since only circulate at around BER  $10^{-1}$ . The

optimum date rate for both CDR FBG filtering is at 10 Gbps with FBG filtering shows better performance compare to FP-FBG. From the analysis, FBG shows better performance in CDR circuit compared to FP-FBG filtering.

**ACKNOWLEDGMENT**

This project is supported by UTeM Grant – PJP/2015/FKEKK(1C)/S01462. Thanks to Universiti Teknikal Malaysia Melaka for the sponsorship.

**REFERENCES**

- [1] Das B., Abdullah M., & Mohd Shah N. (2016). A New All-Optical Signal Regeneration Technique for 10 GB/S DPSK Transmission System. International Journal of Electrical and Computer Engineering (IJECE), 6(2), 859.
- [2] Kaur M., & Mahajan A. (2016). Simulation Analysis of 32 Channel WDM System using SMF 28 Optical Fiber at Various Power Levels. International Journal of Computer Applications, 152(3), 17-20.
- [3] Muthumani I., Ayannar N. (2014). RZ Based Dispersion Compensation Technique in DWDM System for Broadband Spectrum. International Journal of Electrical and Computing Engineering 1(1), 1-7.
- [4] Yen, C., & Chen, W. (2016). A Study of Dispersion Compensation of Polarization Multiplexing-Based OFDM-OCDMA for Radio-over-Fiber Transmissions. Sensors, 16(9), 1440.
- [5] Idris, S. K., Osadola, T. B. and Glesk, I. (2013). Investigation of all-optical switching OCDMA testbed under the influence of chromatic dispersion and timing jitter. Journal of Engineering and Technology, 4(1), 51-65.
- [6] Wang, L., Zhao, X., Zhao, L., Lou, C., Lu, D., Sun, Y. and Wang, W. (2010). 40 Gbits/s All-optical Clock Recovery for Degraded Signals using an Amplified Feedback Laser. APPLIED OPTICS, 49(34), 6577-6581.
- [7] Brox, O., Bauer, S., Radziunas, M., Wolfrum, M., Sieber, J., Kreissl, J., Sartorius, B., and Wnsche, H.(2003). High-frequency Pulsations in DFB Lasers with Amplified Feedback. IEEE Journal of Quantum Electronics, 39(11), 1381-1387.
- [8] Kaur A., & Singh G. (2015). Performance Comparison of various detection techniques for SAC-OCDMA system using DW and MDW Code. International Conference and Workshop on Computing and Communication (IEMCON).
- [9] Contestabile, G., Calabretta, N., Ciaramella, E. and Presi, M. (2005). A Novel 40 Gb/s NRZ All-optical Clock Recovery. CLEO 2005 Baltimore. 452-454.
- [10] Von Lerber, T., Honkanen, S., Tervonen, A., Ludvigsen, H. and Kupperts, F. (2009). Optical clock recovery methods: Review (Invited). Optical Fiber Technol., 15(4), 363-372.
- [11] Li, X., Kim, C. And Li, G. (2004). All-optical Passive Clock Extraction of 40 Gbit/s NRZ Data Using Narrow-band Filtering. Opt. Express, 12(14), 3196-3203.
- [12] Manas, S., Gopakumar, V. T., Srinivasan, B. And Venkitesh, D. (2016). Performance Analysis of All-optical Clock Recovery Using Fabry-Perot Fiber Bragg Gratings. 13th International Conference on Fiber Optics and Photonics, OSA Technical Digest (online) (Optical Society of America), paper Tu2A.4
- [13] Chintakindi R., & Rajesh S. P. S. (2016). Vital Role of FBG Sensors – 2012 Developments in Electrical Power Systems. International Journal of Electrical Transformation and Restructuring 1.1(1), 15-21.
- [14] Abd El-Khaleq E., El-Sayed Y., Ismail T., & Mostafa H. (2016). Electrical and optical clock and data recovery in optical access networks: a comparative study. International Journal Of Communication Systems, 29(17), 2555-2564.
- [15] M. J. Alam, M. Guoqing H., & Mehrab M. (2014). Improvement of Bit Error Rate in Fiber Optic Communications. International Journal of Future Computer and Communication, 3(4), 281-286.
- [16] Hossain M. S., Howlader S., & Basak R. (2015). Investigating the Q-factor and BER of a WDM System in Optical Fiber Communication Network by using SOA. International Journal of Innovation and Scientific Research, 13(1), 315-322.
- [17] Ismail, T. & Mostafa, H. (2015).A wide FBG-based optical clock and data recovery for optical access networks. ICTON 2015. Tu.P.11.