

Modeling of Filtration Process Using PSO-Neural Network

Z.Yusuf^{1,2}, N. Abdul Wahab¹ and S. Sahlan¹

^{1,2}Department of Control and Mechatronic Engineering
Faculty of Electrical Engineering,

Universiti Teknologi Malaysia, Skudai, Johor, Malaysia.

²Faculty of Electrical Engineering,

Universiti Teknologi MARA, Shah Alam, Selangor, Malaysia.

zakariah2@live.utm.my

Abstract—Modeling of membrane filtration process is a challenging task because it involves many interactions from biological and physical operation behavior. Membrane fouling in filtration process is too complex to understand and to derive a robust model become very difficult. The aim of this paper is to study the potential of neural network based dynamic model for submerged membrane filtration process. The purpose of the model is to represent the dynamic behavior of the filtration process therefore the model can be utilized in the prediction and control. The neural network model was trained using particle swarm optimization (PSO) technique. Three methods of PSO are compared to obtained an optimal model which are random PSO (RPSO), constriction factor PSO (CPSO) and inertia weight PSO (IW-PSO). In the data collection, a random step was applied to the suction pump in order to obtained the permeate flux and transmembrane pressure (TMP) dynamic. The model was evaluated in term of %R², root mean square error (RMSE_e) and mean absolute deviation (MAD). The result of proposed modeling technique showed that the neural network with PSO is capable to model the dynamic behavior of the filtration process.

Index Terms—Filtration; MBR; Model; PSO.

I. INTRODUCTION

Membrane bioreactor (MBR) is recognized as the best alternative solution for conventional activated sludge (CAS) system for wastewater treatment. The main different between MBR and conventional system is the application of membrane filtration that can produce better effluent quality compared with the conventional system. However, membrane filtration system still struggles from many issues such as fouling and energy efficiency [1][2] [3]. Fouling can be defined as undesirable of the accumulation of matter such as colloidal, particulate, solute materials, microorganism, cell debris on the membrane during filtration process [4]. Fouling can lead to membrane clogging where the membrane pore will be blocked by solid material. When this phenomenon occurs, the transmembrane pressure (TMP) will be risen or permeate flux will be declined. Proper cleaning method need to be employed at the right time in order to maintain the filtration performance. This cleaning procedure will increase the filtration cost if it not carefully schedule and implemented. If the fouling in membrane filtration cannot be controlled it will lead to the membrane damage.

The development of a reliable prediction model for membrane filtration system is crucial in order to improve the

performance of the membrane filtration system in MBR plant[5][6]. This prediction model can help the plant operator to predict the filtration performance under different operation settings and suitable control strategies can be developed to enhance the filtration process in term of quality and cost.

One in particular, Geissler et al [7] developed two models which are semi empirical model and ANN based model for permeate flux modeling in submerged capillary MBR. The ANN model was based on Elman neural network structure where the permeate flux is predicted. Nine inputs were used in the model and the inputs were TMP, rate of transmembrane pressure change, TMP during backwash, filtration cycle length, backwash cycle length, solid retention time (SRT), total suspended solids (TSS), temperature and oxygen decay. When compared, both techniques yield very good results. The semi empirical model required small input variables compared to ANN. However, the ANN model gave high accuracy with the average error of 2.7%.

The modeling of submerged membrane bioreactor (SMBR) using ANN model was demonstrated in [8] for flat sheet membrane filtration application of wastewater treatment. The ANN model obtained represented the backwash effect to the permeate flux. Several backwash intervals were tested to the flat sheet filtration. The multilayer neural network was used to model the system with backwashed interval, and filtration interval was used as an input to the model meanwhile flux is used as the output. Another ANN application performed in [9], the development of ANN model for effluent quality for SMBR treating cheese whey wastewater was demonstrated. In [13], the model obtained is used to predict chemical oxygen demand (COD), ammonia, nitrate and phosphate concentrations. Meanwhile in [14], the submerged membrane flocculation hybrid systems for synthetic wastewater treatment filtration model was developed using different types of neural network structure. In [14], multilayer perceptron neural network (MLPNN), radial basis function neural network (RBFNN) and general regression neural network (GRNN) were compared in terms of their performance. The results showed MLPNN gives smallest error compared with other method. Thus, the GRNN and RBFNN still give reliable and acceptable performance for this filtration application.

Meanwhile, the application of ANN using the conventional back propagation (BP) algorithm for training

had facing a few problems such as slow convergent and the algorithm has tendency to tarp in the local minima[10]. Therefore, the application of heuristic search optimization technique is one of the solutions to this problem. Several works have been found in literature to find an optimal weight and bias value in the training of the neural network. Among the widely used heuristic search algorithm for ANN model is a genetic algorithm (GA). The GA was used in [1-3] to train the neural network model to various applications. There are also reported the successful application of gravitational search algorithm (GSA) in optimizing the ANN model such as in [11] and [12]. The particle swarm optimization (PSO) had become very effective optimization in many fields. The algorithm is fast and very reliable in searching for minimization. There are few well known type of PSO algorithm such as random PSO (RPSO), constriction factor PSO (CPSO) and inertia weight PSO (IW PSO). This algorithm had been tested in many neural networks application before such as in [13][14] and [15].

This work is focusing on the development of membrane filtration process model using neural network with dynamic structure train by three types of PSO comprising RPSO, CPSO and IWPSO. These three algorithms will be used to search for the best weights and biases of the recurrent neural network model. The trained models are compared in term of its accuracy on the training and testing of membrane filtration data set using several performance measurement techniques such as R^2 , MSE and MAD.

II. EXPERIMENT SETUP

The data set is collected from the membrane bioreactor pilot plant located in Process Control Lab, Faculty of Electrical Engineering, Universiti Teknologi Malaysia (UTM). Figure 1 shows the plant schematic diagram. The experiments were carried out in single tank submerged membrane bioreactors, with working volume of 16 L Palm Oil Mill Effluent (POME) taken from Sedenak Palm Oil Mill Sdn. Bhd. in Johor, Malaysia. The aeration during filtration is set around 6 to 8 standard litter per minute (SLPM). In term of the filtration system data collection, random steps input were given to the suction pump to stimulate the dynamic behavior of the process. Mean while the flux and TMP are the output measurement of the filtration system. Figure 2 shows the data collected from the SMBR pilot plant.

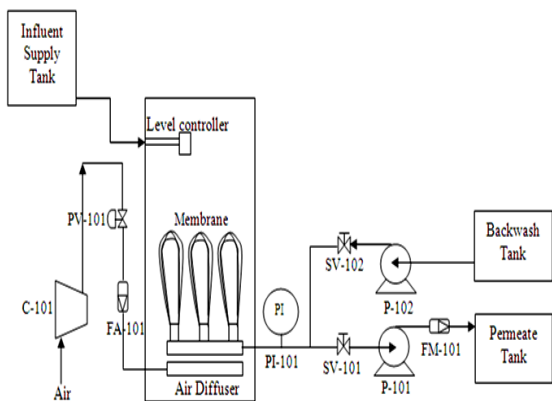

Figure 1: Plant Schematic

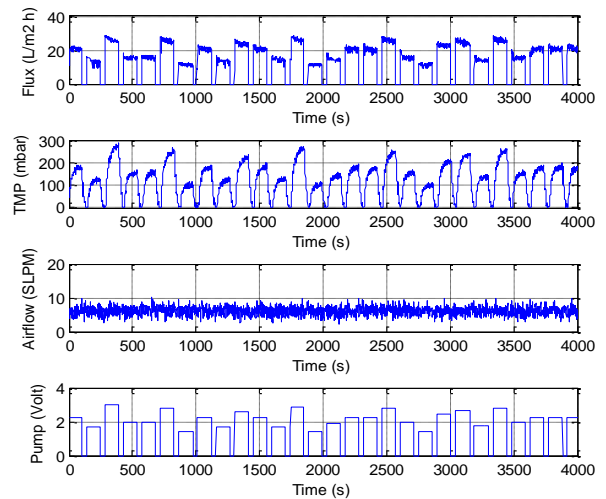

Figure 2: Experimental data

In this work, Polyethersulfone (PES) material with approximately 80-100kda pore size and the surface area is about 0.35 m² membrane is used in the filtration system.

Dynamic neural network model is a mathematical model that developed based on the past input and past output of the system. The training algorithm is employed to obtain suitable weights and biases of the network in order to minimize the error in the training procedure. In this work, the PSO techniques will be used to train the RNN model. Figure 3 shows the basic structure of the recurrent neural network model

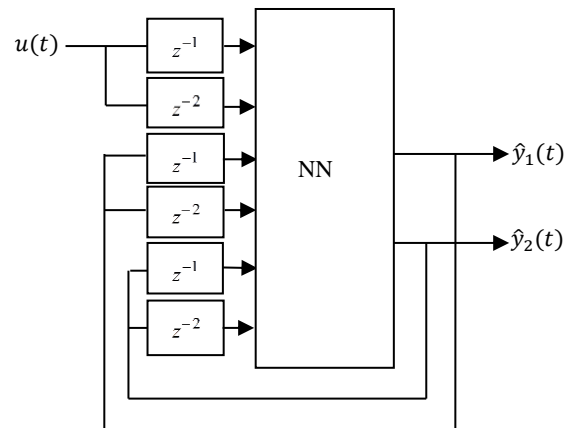

Figure 3: Recurrent Structure

The neural network equation is represents as:

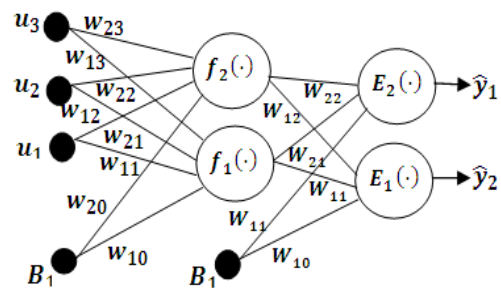

Figure 4: Neural Network Structure [16]

Neural network structure can be presented as:

$$\hat{y}_1(t) = F_i \left[\sum_{j=1}^{n_h} W_{ij} f_j \left(\sum_{l=1}^{n_\phi} w_{lj} + w_{j0} \right) + W_{i0} \right] \quad (1)$$

Where $\hat{y}_i(t)$ is the prediction output. F_i is the function of the network, u is the input vector, W_{ij} and B represent the network connection layer weights and biases. The model is validated using three evaluation techniques such as R^2 , mean square error (MSE) and mean absolute deviation (MAD).

$$MSE = \frac{\sum |\hat{y}_i - y_i|^2}{N} \quad (2)$$

Where \hat{y}_i is the predicted value and y_i is the actual value from the measurement data and N is the number of data point.

$$MAD = \frac{\sum |x_i - \bar{x}_i|}{N} \quad (3)$$

Where x_i is the predicted value and the \bar{x}_i is the mean of the predicted value.

III. PSO ALGORITHM

Particle swarm optimization (PSO) is inspired by a group of animals hunting behavior. This heuristic search optimization is very effective in finding optimal solution for many problems. In the PSO algorithm, number of swarm must be selected to search for the solution. In each of the swarm contain of individuals that call a particle. The PSO main algorithm is to update the position of each particle with the estimated velocity. Each of the components of the velocity equation is represents of the exploration ability and capability of individual learning as well as social learning. The RPSO velocity update is presented in equation 4.

$$V_{id} = V_{id} + C_1(pBest - X_{id}) \times rand_1 + C_2(gBest - X_{id}) \times rand_2 \quad (4)$$

Where v_{id} is the velocity update of the particles. C_1 and C_2 are the constant, while $gBest$ and $pBest$ are the personal and global best solution respectively. $rand_1$ and $rand_2$ is the random number [0, 1].

The inertia weight PSO velocity update equation is given by:

$$V_{id} = wV_{id} + C_1(pBest - X_{id}) \times rand_1 + C_2(gBest - X_{id}) \times rand_2 \quad (5)$$

where,

$$w = \left[\frac{(w_1 - w_0)}{(maxiter - 0)} \right] \times [iter] + w_0 \quad (6)$$

Where w_0 is the initial weight (0.9), w_1 is the value of final weight (0.4), $maxiter$ is the maximum iteration while $iter$ is the iteration.

The constriction factor PSO is given by:

$$V_{id} = x(V_{id} + C_1(pBest - X_{id}) \times rand_1 + C_2(gBest - X_{id}) \times rand_2) \quad (7)$$

Where,

$$\chi = \frac{2}{2 - \varphi - \sqrt{\varphi^2 - 4\varphi}}, \varphi = c1 + c2, \varphi > 4 \quad (8)$$

The positions X_{id} update equation is given by:

$$X_{id} = X_{id} + V_{id} \quad (9)$$

The PSO algorithm execution flow chart is shown in figure 5.

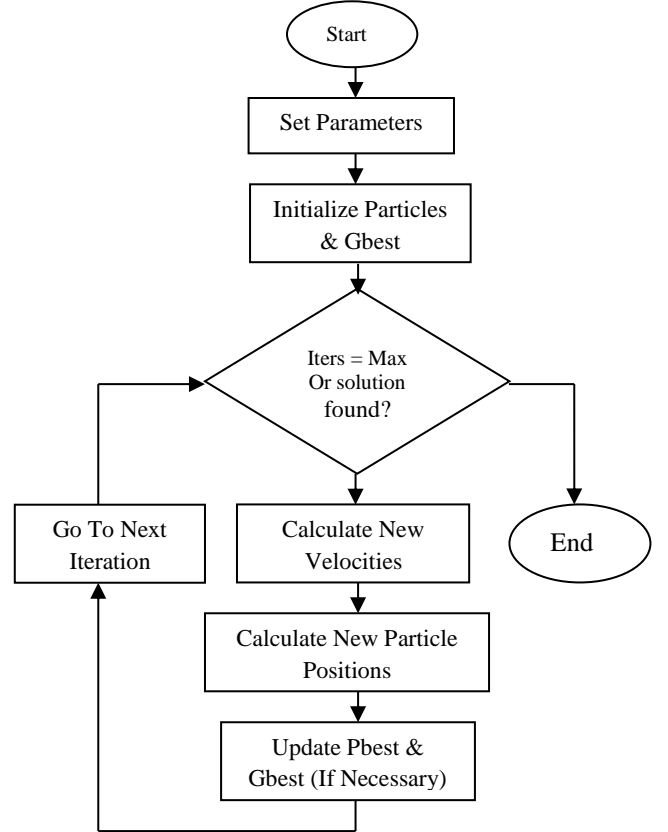

Figure 5: PSO Flow Chart

IV. RESULT AND DISCUSSION

The model training using various PSO results showed a different performance of each algorithm for both flux and TMP. The objective function of the PSO is to minimize the MSE of the model and actual data. Based on the training result, the IW PSO demonstrates a better performance in term of it convergent speed and ability to find the global minimum followed by CPSO and RPSO. Figure 6 shows the convergent curve from all PSO algorithms. In term of MSE performance, IW PSO gives the most accurate result with MSE 0.0048 for permeate flux and 0.0012 for the TMP. The second best performance of the PSO algorithm is CPSO with 0.0053 for the permeate flux and 0.0013 for the MSE. The RPSO gave the worst performance with MSE for permeate flux is 0.0059 while the MSE for TMP is 0.0015. The models were also evaluated using the $\%R^2$ and MAD. Both of these criteria indicate the same trend as the MSE with IW PSO perform better than the others. Table 1 shows the performance of all PSO trained model for permeate flux while Table 2 shows the models evaluation for TMP.

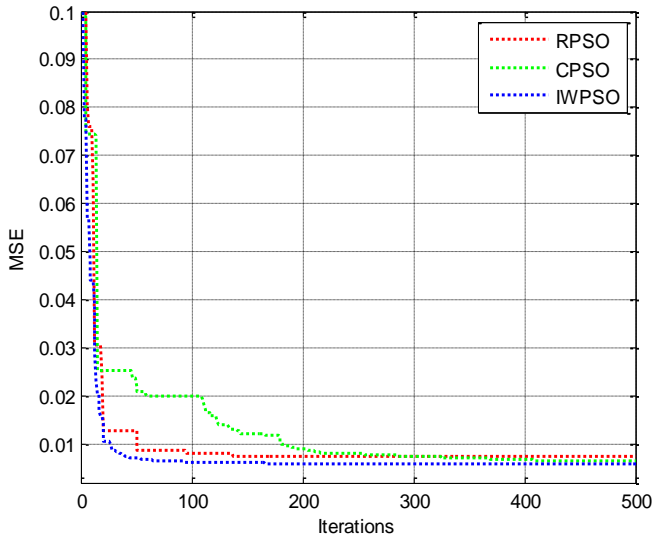

Figure 6: Convergence Curve of the Training Algorithms

Table 1
Training Result for Permeate Flux

	RPSO	CPSO	IW PSO
MSE	0.0059	0.0053	0.0048
%R ²	94.2153	94.8	95.2
MAD	0.0379	0.0356	0.0302

Table 2
Training Result for TMP

	RPSO	CPSO	IW PSO
MSE	0.0015	0.0013	0.0012
%R ²	97.8	98.1	98.2
MAD	0.0277	0.0273	0.0270

The comparisons of the IW PSO model with actual data was plotted in the figure 7 and 8 for TMP and permeate flux respectively. From the figure, it shows that the model has a good agreement with the actual data.

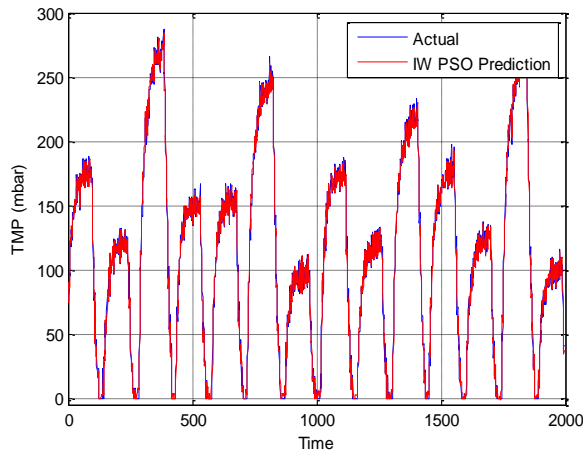

Figure 7: TMP model training result

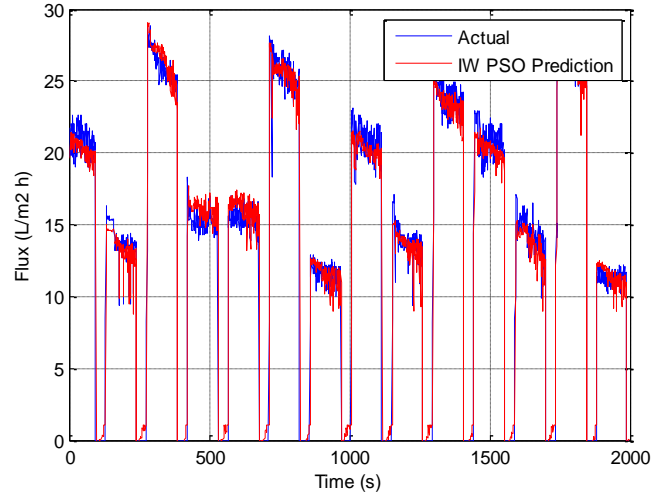

Figure 8: Permeate flux training result

In the testing result, the training models were validate using testing data set. The performance of the testing result indicate slightly decrement of accuracy for all models. However, the trend of the performances still indicate the similar result with IW PSO gave the best result among the others. The MSE of the IW PSO showed 0.0050 for the permeate flux and 0.0012 for the TMP. The %R² value for IW PSO is 94.8 for permeate flux and 98.3 for the TMP model. The MAD is 0.0322 and 0.0274 for the permeate flux and TMP respectively. Similar with the training results, performance of the IW PSO still the most excellent followed by the CPSO and the RPSO. Table 3 and Table 4 presents the results for all the validation criterias for permeate flux and TMP model respectively.

Table 3
Testing Result for Permeate Flux

	RPSO	CPSO	IW PSO
MSE	0.0059	0.0054	0.0050
%R ²	93.9	94.5	94.8
MAD	0.0378	0.0368	0.0322

Table 4
Testing Result for TMP

	RPSO	CPSO	IW PSO
MSE	0.0016	0.0014	0.0012
%R ²	97.2	98.2	98.3
MAD	0.0279	0.0275	0.0274

The IW PSO testing result was plotted to compare with the actual data. Figure 9 and 10 shows the permeate flux and TMP respectively. From the plotting result, it indicates that the model is able to replicate the actual data accordingly.

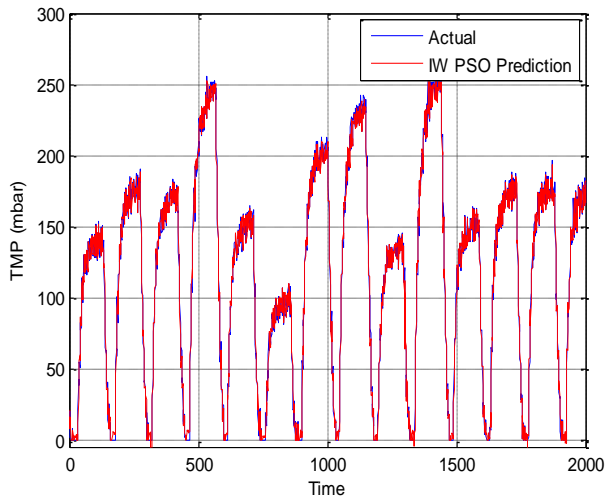

Figure 9: TMP model testing result

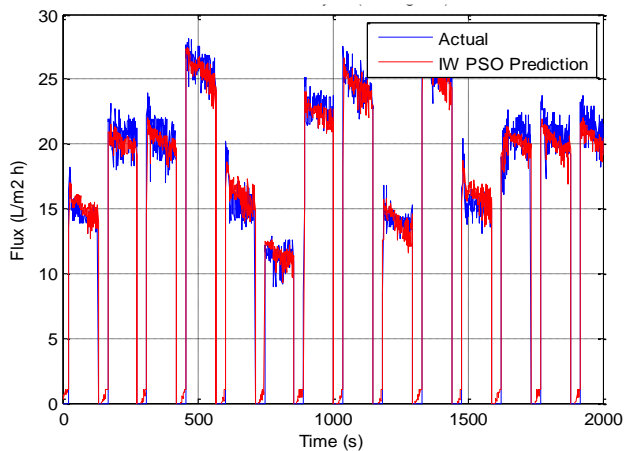

Figure 10: Permeate flux testing result

V. CONCLUSION

This paper proposes a neural network modeling with dynamic structure train by PSO algorithm to model the membrane filtration system. From the result, it showed that this technique is capable to model the dynamic of submerged membrane filtration. In term of the PSO algorithms comparison, the IW PSO gives the best optimization of the model followed by the CPSO and RPSO. The training and testing result showed a good agreement between actual and predicted data. The model is expected to be very useful to facilitate in designing suitable control system.

ACKNOWLEDGMENT

The authors would like to thank the Research University Grant (GUP) vote 13H70, Universiti Teknologi Malaysia for

the financial support. The first author wants to thank the Universiti Teknologi MARA (UiTM) and the MOE for the TPM-SLAI scholarship.

REFERENCES

- [1] S. Judd, *The MBR Book Principles and Applications of Membrane Bioreactors in Water and Wastewater Treatment*, Second Edi. Elsevier, 2010.
- [2] P. Le-Clech, V. Chen, and T. a. G. G. Fane, "Fouling in membrane bioreactors used in wastewater treatment," *J. Memb. Sci.*, vol. 284, no. 1–2, pp. 17–53, Nov. 2006.
- [3] E. Akhondi, F. Wicaksana, and A. Gordon, "Evaluation of fouling deposition, fouling reversibility and energy consumption of submerged hollow fiber membrane systems with periodic backwash," *J. Memb. Sci.*, vol. 452, pp. 319–331, 2014.
- [4] S. Judd, "Fouling control in submerged membrane bioreactors," *Water Sci. Technol.*, vol. 51, no. 6–7, pp. 27–34, 2005.
- [5] Q. Liu and S. Kim, "Evaluation of membrane fouling models based on bench-scale experiments: A comparison between constant flowrate blocking laws and artificial neural network (ANNs) model," *J. Memb. Sci.*, vol. 310, pp. 393–401, 2008.
- [6] M. Kim, B. Sankararao, S. Lee, and C. Yoo, "Prediction and Identification of Membrane Fouling Mechanism in a Membrane Bioreactor Using a Combined Mechanistic Model," *Ind. Eng. Chem. Res.*, vol. 52, pp. 17198–17205, 2013.
- [7] S. Geissler, T. Wintgens, T. Melin, and K. Vossenkaul, "Modelling approaches for filtration processes with novel submerged capillary modules in membrane bioreactors for wastewater treatment," *Desalination*, vol. 178, pp. 125–134, 2005.
- [8] A. Aidan, N. Abdel-Jabbar, T. H. Ibrahim, V. Nenov, and F. Mjalli, "Neural network modeling and optimization of scheduling backwash for membrane bioreactor," *Clean Technol. Environ. Policy*, vol. 10, no. 4, pp. 389–395, Dec. 2007.
- [9] H. Hasar and C. Kinaci, "Modeling of submerged membrane bioreactor treating cheese whey wastewater by artificial neural network," *J. Biotechnol.*, vol. 123, pp. 204–209, 2006.
- [10] S. Mirjalili, S. Z. Mohd Hashim, and H. Moradian Sardroudi, "Training feedforward neural networks using hybrid particle swarm optimization and gravitational search algorithm," *Appl. Math. Comput.*, vol. 218, no. 22, pp. 11125–11137, Jul. 2012.
- [11] Z. Jadidi, V. Muthukkumarasamy, E. Sithirasanen, and M. Sheikhan, "Flow-Based Anomaly Detection Using Neural Network Optimized with GSA Algorithm," *2013 IEEE 33rd Int. Conf. Distrib. Comput. Syst. Work.*, pp. 76–81, Jul. 2013.
- [12] M. Sheikhan and Z. Jadidi, "Flow-based anomaly detection in high-speed links using modified GSA-optimized neural network," *Neural Comput. Appl.*, vol. 24, no. 3–4, pp. 599–611, Nov. 2012.
- [13] J. Zhou, Z. Duan, Y. Li, J. Deng, and D. Yu, "PSO-based neural network optimization and its utilization in a boring machine," *J. Mater. Process. Technol.*, vol. 178, no. 1–3, pp. 19–23, Sep. 2006.
- [14] K. W. Chau, "Application of a PSO-based neural network in analysis of outcomes of construction claims," *Autom. Constr.*, vol. 16, no. 5, pp. 642–646, Aug. 2007.
- [15] L. Zhifeng, P. Dan, W. Jianhua, and Y. Shuangxi, "Modelling of Membrane Fouling by PCA-PSOBP Neural Network," *2010 Int. Conf. Comput. Control Ind. Eng.*, vol. 34, pp. 34–37, 2010.
- [16] M. Nørgård, O. Ravn, N. K. Poulsen, and L. K. Hansen, *Neural Networks for Modelling and Control of Dynamics System: A Practitioner's Handbook*. Springer-Verlag London, 2000.