

# Highly Sensitive Portable Liquid Petroleum Gas Leakage Detector

Z. Mohd. Hussin, M. S. Sulaiman, P. T. Arasu

Universiti Kuala Lumpur British Malaysian Institute, 53100 Gombak, Selangor, Malaysia  
zarinahussin@unikl.edu.my

**Abstract**—A simple, low cost and portable handheld liquid petroleum gas detector is reported in this paper. This battery powered handheld device is fitted with an MQ2 gas sensor and the output voltage of the sensor varies in accordance with the concentration of the gas in the surrounding. The sensor is connected to a microprocessor to display the output and produce an alarm when gas leakage is detected. The concentration of the gas present in the atmosphere is measured and displayed with a detection limit of 50 ppm. The sensor demonstrated high sensitivity towards gas leakages with the response and recovery times of 5 seconds and 8 seconds respectively.

**Index Terms**—Gas Sensor; MQ2 Sensor; Arduino Uno; Liquid Petroleum Gas; Microprocessor.

## I. INTRODUCTION

Liquefied Petroleum Gas (LPG) is made up of a mixture of hydrocarbon gasses such as propane and butane. Both gasses are highly flammable and can pose multiple dangers such as explosions as well as health issues if inhaled [1]–[3]. These gasses are odourless, therefore Ethanethiol is added as an odorant, so that leakages can easily be detected [4]–[6]. Other common odorants are amyl mercaptane and tetrahydrothiophene which comply with the EN589 international standard.

LPG is commonly used in households as cooking gas. In its natural state, it is in a gaseous form and is pressurized and compressed into a liquid form for easy storage and usage. It is usually stored in tanks or piped into buildings. LPG is also rapidly gaining popularity as a low cost and clean burning fossil fuel for internal combustion engines such as in cars. Leakage of LPG can be very serious as it is highly flammable and if inhaled, can cause hypoxia [7], [8]. Repeated exposure to LPG can cause damage to the heart, lungs and kidneys.

LPG leaks can be detected by our senses, as shown in Figure 1, such as sight, where we can see the gas escaping out from a container, smell, where there is a distinct smell of gas as well as the sound of gas leaking where we can hear a ‘hissing’ noise. Any one, two or all three of these senses detected from the leaks is vital, especially in our daily life. However, this is only possible when the gas leak is located very near to a person or it is in a large volume of leakage.

Small unnoticeable gas could leak into the atmosphere and accumulate to a dangerous amount. Gas leakage detection systems are essential to avoid any disasters to occur. Such disasters, which happened in Malaysia, have been reported through “The Star Online”. Posted on 5 April 2016 at 12:44pm, 8 people were injured at the Midvalley Megamall in Kuala Lumpur whereas on 28 September 2011 at 12:00am, 4 people were injured at the Empire Shopping Complex, Subang

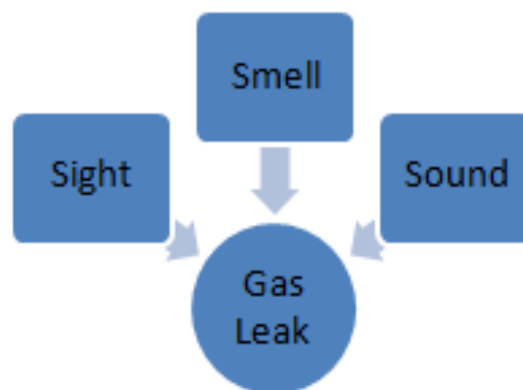

Figure 1: Warning elements of gas leakage

Jaya which resulted in a total damage up to millions of ringgits. Many more small scale explosions have occurred in homes and vehicles using LPG tanks that caused in loss of lives and properties.

LPG is relatively safe when properly contained in gas tanks, however, when there is leakage, it is hazardous. If LPG escapes from the tank, it could form a dense vapor cloud which can become highly flammable and often explosive when exposed to a spark or flame. Also, the LPG gas cylinder vapour pressure varies with different values of temperature and the related chart is shown in Table 1. At higher temperatures, such as in Malaysia, the pressure inside the LPG tanks can reach extremely high levels. Even a small puncture or crack can lead to a large amount of gas escaping from a tank.

Table 1  
LPG Vapour Pressure Chart [9]

Temperature (°C)	Vapour Pressure (kPa)
54	1794
43	1358
38	1186
32	1027
27	883
16	637
-1	356
-18	152
-29	74
-43	0

Several studies have been carried out on gas sensing in recent years. Optical fiber sensors have been deployed to detect gasses such as hydrogen [10]–[12]. These sensors demonstrate high sensitivity towards hydrogen concentrations, however more are suited to remote sensing and are fairly expensive to construct.

In this research, a simple, low cost and portable gas sensor is proposed to detect gas leakage as well as to determine the concentration of the leakage as an early warning system to avoid disasters.

## II. METHODOLOGY

The LPG sensor circuit is designed by using the MQ2 gas sensor. The sensor used in this research project was purchased from Bizchip Technology Center, Malaysia. The MQ2 sensor can be used to detect gasses such as methane, butane, propane and other flammable gasses. It can also be used as a smoke detector. The picture and internal block diagram of the MQ2 sensor is shown in Figures 2 and 3 respectively.

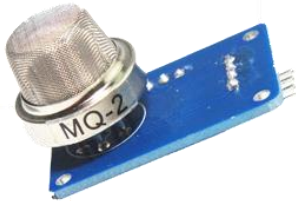

Figure 2: MQ2 Sensor

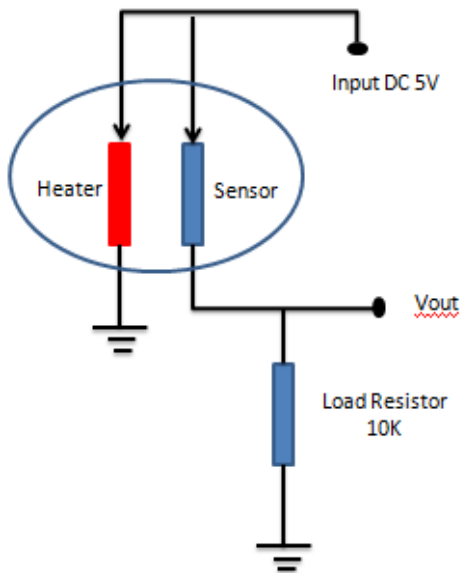

Figure 3: MQ2 Gas sensor connection diagram

The sensor works on the principle of lowering its resistance in the presence of these flammable gasses. When flammable gasses are present, the built-in heater causes these gasses to oxidize. This, in turn, will cause the temperature inside the sensor to increase. The increase in temperature will cause the resistance of the sensor to drop resulting in more current to flow through the load resistor. Therefore, this will result in a corresponding increase in the output voltage ( $V_{out}$ ).

The output of the MQ2 sensor is connected to the input A0 of the Arduino microprocessor. The warning buzzer is connected to output pin 10 of the Arduino chip. The picture of the Arduino Uno is shown in Figure 4.

The block diagram of the gas sensing circuit for the related work is shown in Figure 5. An LCD display is used to display the concentration of the gas which is detected by the sensor. The LCD display and the buzzer are both connected to the Arduino Uno microprocessor.



Figure 4: Arduino Uno

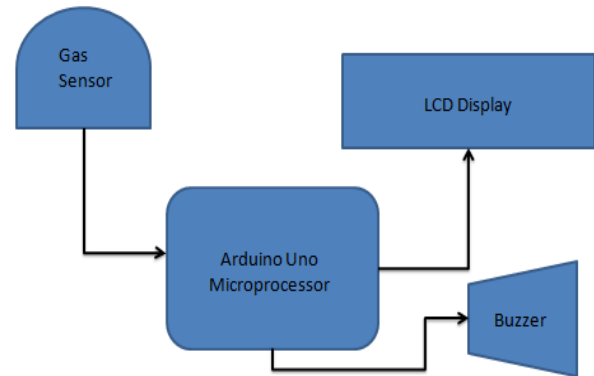

Figure 5: Block diagram of the LPG sensor circuit

The gas concentration is displayed using parts per million. When the concentration of the gas exceeds 300 ppm, the buzzer will produce sound, warning everyone of a gas leakage. The gas concentration threshold can be set by adjusting the programming codes of the Arduino microprocessor.

## III. RESULTS

The LPG gas sensor was tested with different concentrations of gas from a commercial liquefied petroleum gas tank. Gas flow was adjusted using a valve and flow meter. The output voltage of the sensor was measured by using a standard multimeter for calibration purposes. The Arduino microprocessor was programmed to display the gas concentration which is related to the output voltage of the sensor. The calibration of the gas concentration is done by referring to the data sheet of the MQ2 sensor.

The LPG sensor was repeatedly exposed to different concentrations of LPG. The sensor was placed in an enclosed chamber to stabilize the volume of gas surrounding the sensor as well as for accurate concentration measurements. The sensor's performance is displayed in Table 2.

A threshold of 250 ppm was set for LPG warning level. The buzzer produces an alarm when the LPG concentration in the surrounding exceeds 250 ppm. The LPG concentration is displayed on the LCD. This value is obtained from the Arduino microprocessor. The gas concentration is calibrated according to the output voltage of the MQ2 as shown in Figure 6.

The dynamic response of the gas sensor is shown in Figure 7. It can be seen that the response of the sensor is very fast with a response time of less than 1 second which is a highly desirable value for a gas sensor. This is because gas escapes at high speed and even from a low volume of gas, it is sufficient to cause an explosion or fire.

Table 2  
LCD Display for Gas Sensor with Buzzer Status

Concentration of Gas (ppm)	LCD Display	Buzzer
< 100		Off
< 200		Off
< 300		On
< 400		On
> 400		On

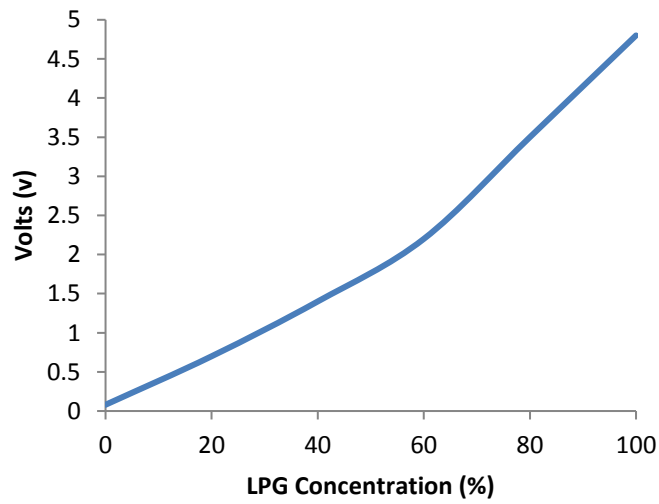

Figure 6: LPG concentration vs output voltage

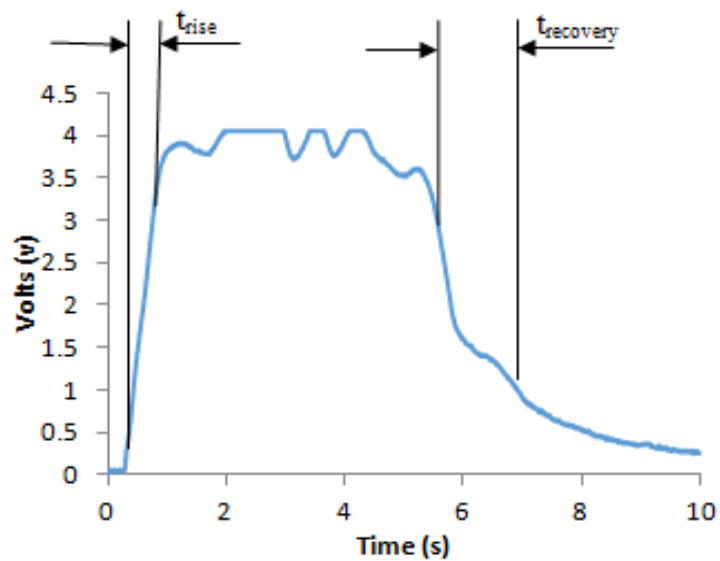

Figure 7: Dynamic response to the gas sensor

#### IV. CONCLUSION

A highly sensitive LPG gas sensor using MQ2 sensor and Arduino microprocessor was developed successfully. The sensor demonstrated high sensitivity towards LPG and was able to detect even low concentrations of LPG of 50 ppm in the atmosphere. Repeatability and stability were also established by the sensor which demonstrated high response with a recovery time of 1 s and 3 s respectively. The sensor demonstrates great potential as a portable gas sensing platform due to having the ability to be used for multiple gas sensing applications. The sensor can be further integrated to detect smoke as well as heat, therefore making it a suitable device for home and office safety applications. Further development can be carried out by incorporating a GSM module to allow remote sensing applications.

#### ACKNOWLEDGMENT

The work reported in this paper is partly supported by the Universiti Kuala Lumpur, Malaysia for Short Term Research Grant (Ref: UniKL/CoRI/STR15109).

#### REFERENCES

- [1] N. Bariha, I. Mani, and V. Chandra, "Journal of Loss Prevention in the Process Industries Fire and explosion hazard analysis during surface transport of liquefied petroleum gas (LPG): A case study of LPG truck tanker accident in Kannur, Kerala, India," *J. Loss Prev. Process Ind.*, vol. 40, pp. 449–460, 2016.
- [2] N. G. Shimpi, S. Jain, N. Karmakar, A. Shah, D. C. Kothari, and S. Mishra, "Applied Surface Science Synthesis of ZnO nanopencils using wet chemical method and its investigation as LPG sensor," *Appl. Surf. Sci.*, vol. 390, pp. 17–24, 2016.
- [3] J. Kim, C. Bae, and G. Kim, "The operation characteristics of a liquefied petroleum gas (LPG) spark-ignition free piston engine," *Fuel*, vol. 183, pp. 304–313, 2016.
- [4] D. Haridas, A. Chowdhuri, K. Sreenivas, and V. Gupta, "Enhanced LPG response characteristics of SnO<sub>2</sub> thin film based sensors loaded with Pt clusters," *Int. J. Smart Sens. Intell. Syst.*, vol. 2, no. 3, pp. 503–514, 2009.
- [5] W. J. W. Hanapi, "Room Temperature of Liquefied Petroleum Gas (LPG) Sensor Based on p-La<sub>2</sub>O<sub>3</sub>/n-Fe<sub>2</sub>O<sub>3</sub>," 2008.
- [6] S. R. Manihar, K. P. Dewagan, and J. Rajpurohit, "Multiple gas Analyzer and Indicator," *Int. J. Mod. Eng. Res.*, vol. 2, no. 4, pp. 2753–2755, 2012.
- [7] T. Soundarya and J. V. Anchitalagammai, "Control and Monitoring System For Liquefied Petroleum Gas (LPG) Detection And," *Int. J. Innov. Res. Sci. Eng. Technol.*, vol. 3, no. 3, pp. 696–700, 2014.
- [8] A. Spiewak and W. Salabun, "A Mobile Gas Detector with an Arduino Microcontroller," *Int. J. Comput. Technol. Appl.*, vol. 6, no. August 2015, pp. 636–641, 2016.
- [9] E. Hahn, "The Properties and Composition of LPG," *ELGAS*, 2015. [Online]. Available: <http://www.elgas.com.au/blog/453-the-science-a-properties-of-lpg>. [Accessed: 14-Jul-2016].
- [10] P. T. Arasu, A. S. M. Noor, and A. Lateef, "Highly Sensitive Plastic Optical Fiber with Palladium Sensing Layer for Detection of Hydrogen Gas," in *2016 IEEE Region 10 Symposium (TENSYP)*, 2016, pp. 390–393.
- [11] J. Dai, M. Yang, X. Yu, and H. Lu, "Optical hydrogen sensor based on etched fiber Bragg grating sputtered with Pd/Ag composite film," *Opt. Fiber Technol.*, vol. 19, no. 1, pp. 26–30, Jan. 2013.
- [12] K. Schroeder, W. Ecke, and R. Willsch, "Optical fiber Bragg grating hydrogen sensor based on evanescent-field interaction with palladium thin-film transducer," *Opt. Lasers Eng.*, vol. 47, no. 10, pp. 1018–1022, 2009.