



Missouri University of Science and Technology  
Scholars' Mine

---

Materials Science and Engineering Faculty  
Research & Creative Works

Materials Science and Engineering

---

01 Jun 1998

## Mixed Electron Emission from Doped Pb(Zr,Ti)O<sub>3</sub> Ceramics: Microstructural Aspects

Weiming Zhang

Wayne Huebner

Missouri University of Science and Technology, huebner@mst.edu

Follow this and additional works at: [https://scholarsmine.mst.edu/matsci\\_eng\\_facwork](https://scholarsmine.mst.edu/matsci_eng_facwork)

 Part of the [Materials Science and Engineering Commons](#)

---

### Recommended Citation

W. Zhang and W. Huebner, "Mixed Electron Emission from Doped Pb(Zr,Ti)O<sub>3</sub> Ceramics: Microstructural Aspects," *Journal of Applied Physics*, vol. 83, no. 11, pp. 6034-6037, American Institute of Physics (AIP), Jun 1998.

The definitive version is available at <https://doi.org/10.1063/1.367472>

This Article - Journal is brought to you for free and open access by Scholars' Mine. It has been accepted for inclusion in Materials Science and Engineering Faculty Research & Creative Works by an authorized administrator of Scholars' Mine. This work is protected by U. S. Copyright Law. Unauthorized use including reproduction for redistribution requires the permission of the copyright holder. For more information, please contact [scholarsmine@mst.edu](mailto:scholarsmine@mst.edu).

# Mixed electron emission from doped $\text{Pb}(\text{Zr},\text{Ti})\text{O}_3$ ceramics: Microstructural aspects

Weiming Zhang<sup>a)</sup> and Wayne Huebner

*The Department of Ceramic Engineering, University of Missouri–Rolla, Rolla, Missouri 65409*

(Received 22 December 1997; accepted for publication 5 March 1998)

A mixed type electron emission, i.e., simultaneous ferroelectric and plasma emission, was observed with a negative driving pulse applied to doped  $\text{Pb}(\text{Zr},\text{Ti})\text{O}_3$  ceramics in the absence of any external potential on the electron collector. During these emission studies, significant microstructural changes on the emission surface were observed, and corresponded to the different emission modes. Erosion craters at the edge of the electrode and small particles near these craters reflected the formation of a dense plasma there. Comparatively, cavities, i.e., grain pullouts, accumulated on the bare ferroelectric surface, the frequency of which depended upon its distance from the grid. This phenomenon is proposed to be a result of fringing fields and the associated strain energy due to  $90^\circ$  domain switching, which could be seen as an evidence that ferroelectric emission occurred in these areas. © 1998 American Institute of Physics. [S0021-8979(98)06211-2]

## I. INTRODUCTION

Although strong electron emission from ferroelectrics due to fast polarization switching was assigned a new emission name, ferroelectric emission (FE), in 1988,<sup>1</sup> there is continuing debate over whether FE is a new emission phenomenon or just another kind of metal–dielectric emission.<sup>1,2</sup> Both emitters have a geometric configuration of a grid electrode on a dielectric (such as  $\text{BaTiO}_3$ ). Mesyats<sup>3</sup> and Rosenman *et al.*<sup>4</sup> believe that the so-called FE is simply a metal–dielectric emission process. In this model, field enhancement by a factor of the dielectric constant  $K$  in the electrode–dielectric–vacuum triple points induces plasma formation and expansion. However, Gundel<sup>2</sup> and Zhang *et al.*<sup>5</sup> indicate that FE is significantly different from metal–dielectric emission, as the latter cannot explain the lack of delay time between the emission peak and the driving pulse in the absence of any extraction potential on the electron collector. Sputtered Au served as the grid electrode in the FE studies, as compared to the copper wire grid which was simply pressed onto the surface in the metal–dielectric emission studies. Thus, the triple points that undoubtedly existed in the metal–dielectric emission studies were not a major factor in the FE experiments. More convincing, Zhang *et al.*<sup>5</sup> have made parallel emission studies of “normal” ferroelectric  $\text{Pb}_{(1-x)}\text{La}_x(\text{Zr}_y\text{Ti}_{(1-y)})_{1-x/4}\text{O}_3$  ( $x=0.08$ ,  $y=0.65$ ), i.e., PLZT 8/65/35 ( $K \approx 5000$  at  $25^\circ\text{C}$  and 1 kHz), and nonferroelectric PLZT 15/65/35 ( $K \approx 3500$  at  $25^\circ\text{C}$  and 1 kHz). Strong electron emission was observed from PLZT 8/65/35 at a driving field as low as 10 kV/cm. Comparatively, only electromagnetic noise existed for PLZT 15/65/35 at a driving field as high as 30 kV/cm. Note that the two compositions have approximately the same  $K$ . Thus electron emission from FE is indeed a new emission phenomenon.

However, there are some experimental observations that “pure” FE cannot explain convincingly, such as emission

occurring far above the Curie temperature.<sup>6,7</sup> More important, no direct experimental evidence has been shown that the electrons are emitted from the bare surface of ferroelectrics during polarization switching.

Zhang *et al.*<sup>8</sup> have reported that a mixed type emission, i.e., simultaneous FE and plasma emission, is possible. These two were distinguished based on their quite different emission characteristics and by the relationship between the polarization switching current and the emission current measured at the same time. Miyake *et al.*<sup>9</sup> also suggested that electron emission from ferroelectrics was caused not only by the emission of the screening electrons but also by the plasma formed on the surface.

It is quite interesting that, although this research field has been studied for almost 10 years, few scanning electron microscopy (SEM) micrographs showing emission surfaces before and after FE or plasma emission have been presented thus far. In this study the emission surface microstructures were used to help understand the complicated emission process.

## II. EXPERIMENTAL TECHNIQUES

The sample preparation procedure and experimental setup are described in detail in Ref. 8. Disk-shaped samples (diameter  $\varnothing = 19$  mm; thickness  $t = 0.64$  mm) of a commercially available doped  $\text{Pb}(\text{Zr}, \text{Ti})\text{O}_3$ , PZT EC-64 (EDO Co., Salt Lake City, Utah), were prepared using conventional ceramic processing.<sup>10</sup> Ag grid electrodes (300  $\mu\text{m}$  wide, 300  $\mu\text{m}$  apart) were applied by screen printing. The ferroelectric samples were set in the vacuum chamber with the grid electrode side facing the Pt electron collector. Driving pulses were input into the rear electrode of the sample, while the grid electrode was kept at the ground state. The emission current was measured by a digital real time oscilloscope (TDS 380, Tektronix Co., Wilsonville, OR) with a 400 MHz

<sup>a)</sup>Corresponding author; electronic mail: weiming@umr.edu

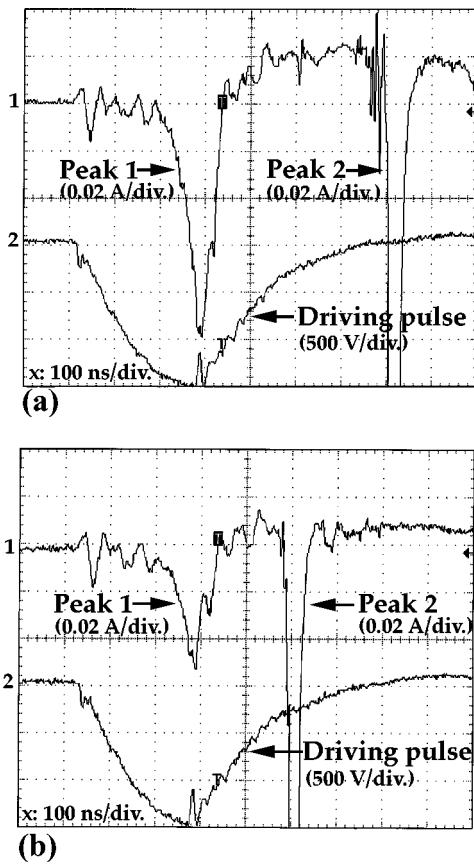

FIG. 1. Typical emission current traces when a negative driving pulse is applied to the sample with no extraction potential on the collector. Note that (a) and (b) are two consecutive recordings (from Ref. 8).

bandwidth. All studies were performed in a vacuum of  $10^{-6}$ – $10^{-8}$  Torr. After the emission studies, samples were inspected using SEM.

### III. RESULTS AND DISCUSSIONS

Typical emission results with only a negative driving pulse applied to the sample and without an extraction potential on the electron collector are shown in Figs. 1(a) and 1(b).

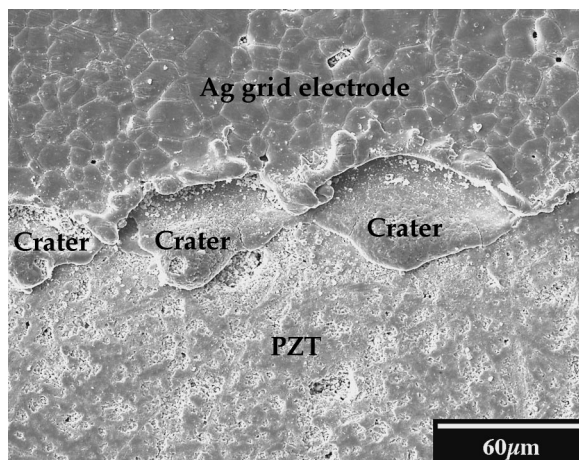

FIG. 2. SEM micrograph of the emission surface after the emission studies (plasma emission region).

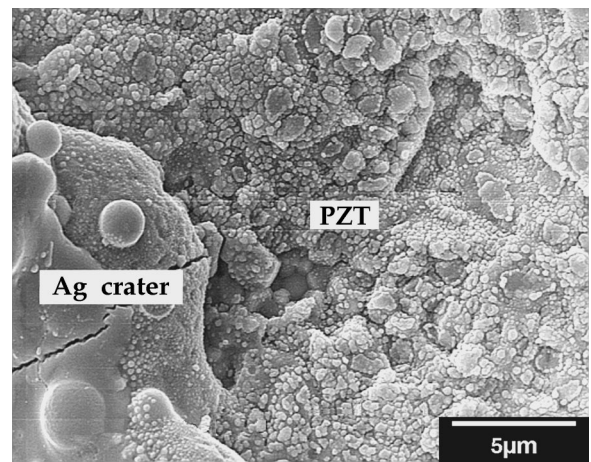

FIG. 3. Higher magnification SEM micrograph of the small particles accumulated near the crater on the grid electrode (plasma emission region).

In earlier work<sup>8</sup> emission peak 2 was identified to be due to plasma emission for several reasons, including unstable emission characteristics, a delay time between the emission peak and driving pulse, insensitivity to the driving pulse polarity, and the detection of positive ions. More direct evidence can be found from the SEM micrographs of the emission surface. Many erosion “craters” existed on the edge of the Ag grid electrode shown in Fig. 2, and near these craters many small particles ( $<0.5 \mu\text{m}$ ) were found (seen in Fig. 3). These craters most likely reflect the presence of a dense plasma in these areas. The plasma was induced from the metal–dielectric–vacuum triple points at the edge of the Ag grid electrode. The SEM micrograph shown in Fig. 4 of a polished sample cross section prior to emission shows the presence of small gaps that are microns in size. These gaps are due to imperfect adhesion between the electrode and the ceramic, especially at the edge of the electrode. The enhancement of the electric field in these gaps,  $E_g$  (kV/cm), is given by<sup>3,4,11</sup>

$$E_g \approx KE_a, \tag{1}$$

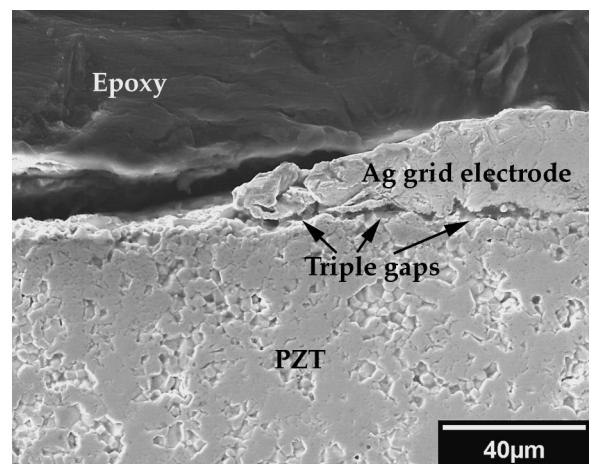

FIG. 4. SEM micrograph of the polished sample cross section showing the triple gaps between the ceramic and the grid electrode (from Ref. 8).

where  $K$  is the dielectric constant of the material, and  $E_a$  is the applied electric field (kV/cm).

Since the dielectric constant for PZT EC-64 is  $\approx 1300$  (25 °C, 1 kHz), and  $E_a = \pm 20$  kV/cm,  $E_g = \pm 2.6 \times 10^4$  kV/cm. Under this high electric field, classic field electron emission from the triple points will undoubtedly occur. This is known as ‘‘prebreakdown’’ field emission if the gap is seen as a classical diode. The breakdown of this gap can be either cathode initiated or anode initiated. The Ag electrode plays a critical role because of its low melting point. When a electric field is applied, the field emission current flowing through a point on the electrode causes it to heat up. Subsequently it melts and vaporizes, thus in the end leading to breakdown. This effect is the reason that craters were found on the edge of the grid electrode. As vapor fills the gap, ions form and electron avalanche occurs. Consequently the gap conductance increases and the discharge changes into an arc.

The particles near the erosion craters shown in Fig. 3 might be Ag particles, as the potential of the bare surface near the grid electrodes is negative when polarization switching occurs after a negative driving pulse was applied to the rear electrode of the sample. Thus the positive ions ( $\text{Ag}^+$ ) were separated from the plasma cloud and then deposited onto the bare surface of the ferroelectric. This is also the reason that no positive current peak was detected during most of the emission studies. However, this hypothesis could not be confirmed by energy-dispersive x-ray spectrometry (EDS), as these particles are too small ( $< 0.5 \mu\text{m}$ ), and the base material contains Pb. Thus due to the Monte Carlo effect most secondary electrons are from the base material.

Also from earlier work,<sup>8</sup> the emission peak 1 in Fig. 1 has been ascribed to ferroelectric emission. This conclusion was based on its emission characteristics, i.e., no delay time between the emission peak and the driving pulse and the relatively stable emission amplitude and the time position. In addition, no ion current was detected. More important, emission corresponded to domain switching. Some clues could also be found from the SEM micrographs. Figures 5(a) and 5(b) are SEM micrographs of the emission surface before and after the emission studies, respectively [note that Figs. 2, 3, and 5(b) are taken from the same sample but of different regions]. Many fresh cavities existed on the ferroelectric bare surface near the edge of the grid electrode after the emission experiments. This might be evidence that high repulsive forces due to fast polarization switching existed on the bare surface of the ferroelectric and that they even ejected some ceramic grains. The grains might have been loosened during sample preparation, i.e., during the polishing procedure. Similar phenomena were observed by Gundel *et al.*<sup>12</sup> when they stated that ‘‘small holes were visible on the bare areas.’’

The reason why these cavities were found mostly near the edge of the grid electrode can be explained as follows. For a sample with a grid electrode, when a driving field is applied, certainly the domains underneath the grid electrode are switched first. The question is, How are the domains far from the grid electrode affected? Two effects, fringing fields and elastic coupling, should be taken into account. Figure 6 shows the electric potential distribution inside and outside a ferroelectric sample (only one segment of an exposed surface

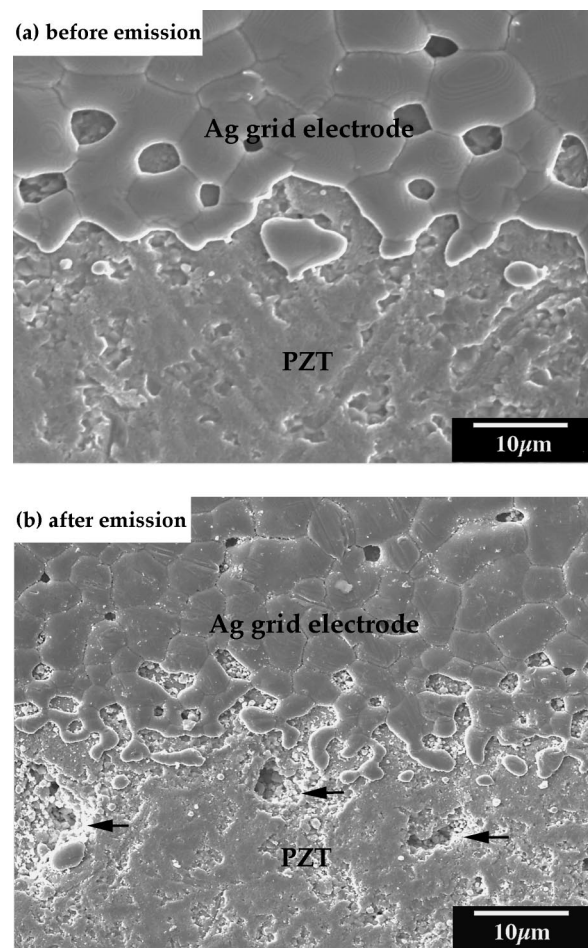

FIG. 5. SEM micrographs of the emission surface (a) before and (b) after the emission studies (ferroelectric emission region).

is shown for simplification) which was produced using SIMION 6.0s, an electrostatic and magnetic field modeling program.<sup>13</sup> In Fig. 6, each thin line represents an equipotential line, and the potential difference between two adjacent lines is 50 V. Underneath the grid electrode, the potential and hence the electric field inside the material are homogeneous. However, in the area between the grid electrodes, a strong potential leakage into the vacuum occurs, and the field on the bare surface decreases with increasing distance from

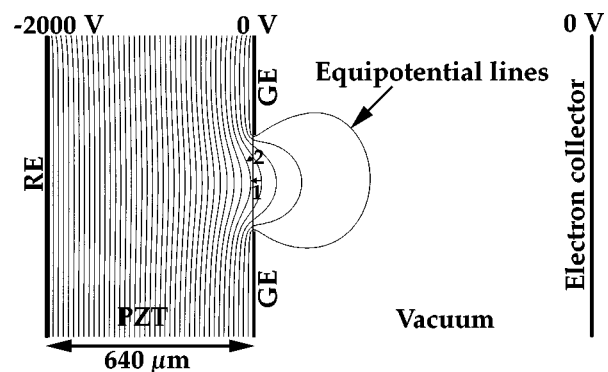

FIG. 6. The potential distribution inside and outside the ferroelectric. [RE: rear electrode, GE: grid electrode ( $300 \mu\text{m}$ ).]

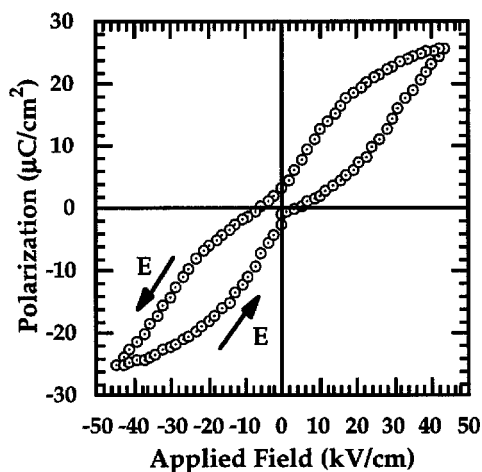

FIG. 7. Hysteresis loop of PZT EC-64 with grid electrodes measured at room temperature (from Ref. 8).

the grid electrode. The fringing field on the middle of the bare surface (point 1) can be calculated approximately from Fig. 6 by

$$E = \frac{\Delta V}{\Delta d}, \quad (2)$$

where  $\Delta V = 50$  V, and  $\Delta d$  is the distance between two adjacent equipotential lines in the middle of the bare surface as shown in Fig. 6 ( $\approx 38 \mu\text{m}$ ). Thus,  $E \approx 14$  kV/cm, compared to the applied field of  $\approx 31.3$  kV/cm, and only 46% of the field strength remained. This field strength is probably too weak to cause domain switching. From the hysteresis loop of the sample shown in Fig. 7, this field strength corresponds to very low polarization ( $\approx 4 \mu\text{C}/\text{cm}^2$ ). This reflects the inherent "hardness" of this composition. Using the same method, the field strength at point 2, which is near the grid electrode, is  $\approx 22$  kV/cm and  $\approx 66\%$  of the field strength remained. This corresponds to an induced polarization of  $\approx 10 \mu\text{C}/\text{cm}^2$ .

In addition to fringing field effects, a domain on the bare surface can also be switched by elastic coupling through strain energy, which is achieved by only a  $90^\circ$  domain reorientation. Two types of domains,  $180^\circ$  and  $90^\circ$  (tetragonal  $71^\circ$  and  $109^\circ$  for rhombohedral), coexist in PZT. The formation or reorientation of  $180^\circ$  domains does not cause a change of elastic strain energy. However, a  $90^\circ$  domain reorientation causes a dimensional change, which induces stresses at the domain wall and intergranular stresses at the grain boundary.<sup>14</sup> Adjacent  $90^\circ$  domains can reorient under the influence of stress, which propagates like a vibrational wave. Certainly the amplitude of this wave would attenuate with increasing distance from the grid electrode.

Thus, due to these two effects, domains near the grid electrode can be expected to be switched. However, the domains in the middle area of the bare surface probably remain unswitched, as is shown schematically in Fig. 8. Therefore, the repulsive electrostatic force due to domain switching can

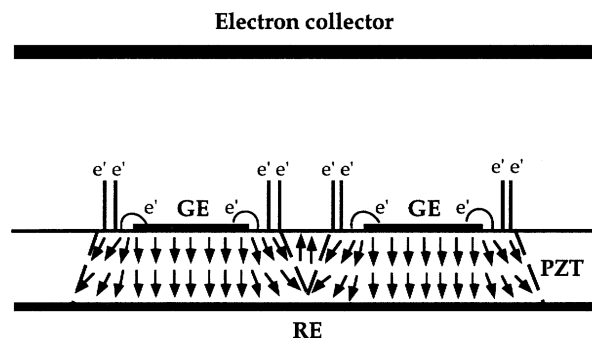

FIG. 8. Schematic diagram of the domain switching distribution after a driving pulse is applied to the ferroelectric sample. (RE: rear electrode, GE: grid electrode.)

be expected to build up only near the grid electrode, and hence the electrons will be ejected mainly from this area.

#### IV. CONCLUSIONS

Simultaneous ferroelectric and plasma emission from doped PZT was observed with only a negative driving pulse applied to the sample and without an extraction potential on the electron collector. Each emission process resulted in regions of different microstructural features on the same emission surface. The existence of micrometer size triple gaps and erosion craters on the edge of the grid electrode before and after the emission studies gave clear evidence that plasma emission due to field enhancement existed in these gaps. Cavities i.e., grain pullouts, were observed, and were correlated to the electric field distribution and the resultant domain switching distribution in the ferroelectric. The fringing field and  $90^\circ$  domain elastic coupling effects suggested that only domains near the grid electrode could be switched, resulting in ferroelectric emission from these areas.

#### ACKNOWLEDGMENTS

This research is sponsored by the U.S. Department of Energy through Allied Signal Federal Manufacturing and Technologies under Contract No. 052G101867. The suggestions from H. Riege (CERN) are deeply appreciated.

- <sup>1</sup>H. Riege, *Le Vide les Couches: Sci. Tech. Appl.* **275**, 398 (1995).
- <sup>2</sup>H. Gundel, *Electron Emission from Ferroelectrics: A New Generation of Pulsed Electron Beam Sources* (Shaker, Aachen, Germany, 1996), p. 101.
- <sup>3</sup>G. A. Mesyats, *IEEE Trans. Dielectr. Electr. Insul.* **2**, 272 (1995).
- <sup>4</sup>D. Shur, G. Rosenman, Y. E. Krask, and V. D. Kugel, *J. Appl. Phys.* **79**, 3669 (1996).
- <sup>5</sup>W. M. Zhang, W. Huebner, S. E. Sampayan, and M. L. Krogh, *J. Am. Ceram. Soc.* (submitted).
- <sup>6</sup>J. Asano, T. Imai, M. Okuyama, and Y. Hamakawa, *Jpn. J. Appl. Phys., Part 1* **31**, 3098 (1992).
- <sup>7</sup>W. M. Zhang, W. Huebner, and G. D. Waddill, *Ferroelectrics* (submitted).
- <sup>8</sup>W. M. Zhang, W. Huebner, S. E. Sampayan, and M. L. Krogh, *J. Appl. Phys.* (in press).
- <sup>9</sup>M. Miyake, S. Ibuka, K. Yasuoka, and S. Ishii, *Jpn. J. Appl. Phys., Part 1* **36**, 6004 (1997).
- <sup>10</sup>W. M. Zhang, Ph.D. dissertation, University of Missouri-Rolla, 1997.
- <sup>11</sup>M. J. Kofoed, *AIEE Trans.* **6**, 999 (1960).
- <sup>12</sup>H. Gundel, J. Handerek, H. Riege, and E. J. N. Wilson, *Ferroelectrics* **110**, 183 (1990).
- <sup>13</sup>D. A. Dahl, *The SIMION 3D User's Manual*, Idaho National Engineering Laboratory, 1994.
- <sup>14</sup>Y. Lee, L. Wu, and J. Chang, *Ceram. Int.* **20**, 117 (1994).