

TECHNICAL TRANSACTIONS

CZASOPISMO TECHNICZNE

MECHANICS

MECHANIKA

1-M/2013

MARIUSZ KRAWCZYK\*

## PROPORTIONAL FLOW CONTROLLER MODEL IN MATLAB-SIMULINK

### MODEL PROPORCJONALNEGO REGULATORA PRZEPIYWU W MATLAB-SIMULINK

#### Abstract

This paper presents a method of creating a model of proportional flow control in Matlab-Simulink. A mathematical model of the controller and power supply system where the regulator is running. Model in Simulink is a block diagram. The individual blocks represent components of the hydraulic system.

*Keywords: simulations, mathematical model, flow control, Matlab Simulink*

#### Streszczenie

W artykule przedstawiono metodę budowy modelu proporcjonalnego regulatora przepływu w programie Matlab-Simulink. Przedstawiono model matematyczny regulatora oraz układu zasilacza w którym pracuje ten regulator. Model w programie Simulink ma postać schematu blokowego. Poszczególne bloki reprezentują elementy układu hydraulicznego.

*Słowa kluczowe: symulacje, model matematyczny, regulator przepływu, Matlab Simulink*

\* MSc. Eng. Mariusz Krawczyk, Institute of Applied Informatics, Faculty of Mechanical Engineering, Cracow University of Technology.

## 1. Introduction

Hydraulic system components – including hydraulic valves – are still intensive development. This development includes both distributors, logical elements, pumps and proportional valves. Commonly used microprocessor control improves the characteristics of proportional elements those components while increasing their range. Hydraulic systems built with them, gain new uses and new features in many cases. This paper discussed issues of creating of a simulation model of proportional flow control.

## 2. Object of research

The object of research is proportional electronically controlled flow control scheme which presented in Fig 1. Consists of of items such as: 1 – solenoid, 2 – body, 3 – bushing, 4 – piston, 5 – displacement transducer, 6 – pin magnet, 7 – spring. The controller consists of a throttle section and section differential. Working fluid flows from port A to port B is suppressed by the throttle slot formed  $f_A$  of the sleeve 3 and the body 2. The volumetric fluid flow rate is proportional to the current the electromagnet 1.

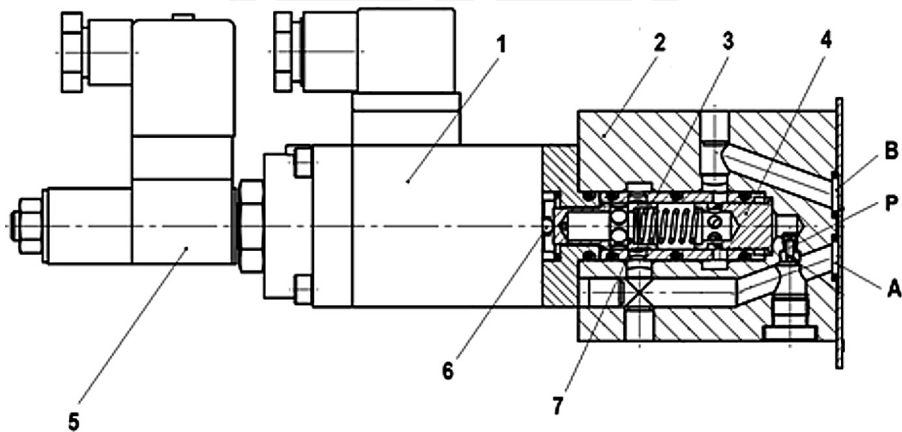

Fig. 1. Diagram of two-way proportional flow control

Rys. 1. Schemat dwudrogowego proporcjonalnego regulatora przepływu

To flow controller appeared working fluid flow slot open stuffing box  $f_A$ . We achieve this by giving an appropriate voltage on electromagnet clamps resulting in the 6 pin coming out of the solenoid moves the sleeve 3, which opens the throttle gap. Working fluid flowing in the canal flows through the slot  $B f_B$  formed on the edge of the piston 4 and body 2. Gap size  $f_B$  specifies the location of the piston 4, which is based on the forces acting on it. On the one hand, it is mainly the sum of the forces: spring 7 and the hydrostatic force flowing liquid, on the other hand liquid hydrostatic force acting on the opposite side of the piston 4, affecting channel P. Moving the plunger through the influence on the position of the spring 7 of the

sleeve 3, which is controlled by encoder. Change the position of the sleeve 3 are adjusted by electronic control system by amending the solenoid voltage. This situation continues until you establish a balance of power between the elements of the flow. In the case of fluid pressure changes following re-establish the balance of forces. As a result, the volumetric flow through the flow control is set by the operator and is independent of the level of pressure of the working medium.

## 2.1. Mathematical model

For the mathematical description of the equations have been used for the balance of forces, torque, expenses, continuous flow, logic and geometrical relationships. The analysis includes mathematical model of the controller and power supply system model which consists of: 1 – electric motor, 2 – hydraulic pump with fixed delivery, 3 – relief valve, 4 – Proportional flow controller, 5 – supply line, 6 – throttle valve, 7 – pressure gauge and pressure transducer, 8 – flowmeter.

Adopted the following simplifying assumptions: the system work in thermal equilibrium state, the system external no leakage, the pump pulse was omitted and the phenomenon of wave, springs in valves have linear characteristics, deformability omitted bodies, individual sections of power lines has become a equivalent bulk modulus of elasticity, ignored liquid flow resistance in the channels of the valves and conduits.

Figure 2 shows the general scheme system.

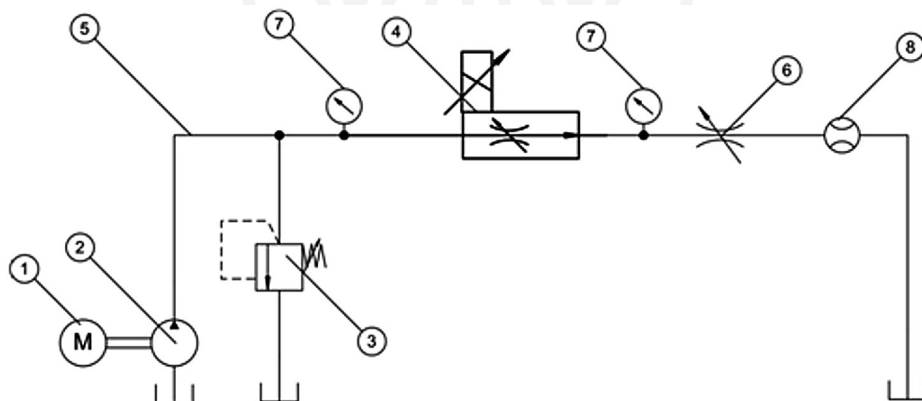

Fig. 2. General diagram of the power supply system and flow controller

Rys. 2. Schemat ogólny układu zasilacza wraz z regulatorem przepływu

### Hydraulic pump

Basic parameters pump operation is volumetric flow rate  $Q_p$  and pump output pressure  $p_2$ . With appropriate simplifying assumptions described pump model

$$Q_p = q_p \frac{\omega_p}{2\pi} \eta_{vp} \quad (1)$$

where:

- $q_p$  – Performance Unit,
- $\omega_p$  – angular velocity of the shaft pump,
- $\eta_{vp}$  – pump volumetric efficiency.

### Power supply line

Liquid flows into the controller with constant flow rates of  $Q_R$ ,  $Q_p$  pump intensity, the supply line  $V_z$  volume and bulk modulus of elasticity substitute  $B_z$ . Flow balance equation can be described by the equation

$$\frac{dp_z}{dt} = (Q_p - Q_R - Q_{zp}) \frac{B_z}{V_z} \quad (2)$$

where:

- $p_z$  – pressure in the supply line,
- $Q_{zp}$  – volumetric flow rate through the overflow valve.

### Flow controller

In Figure 3. shows a simplified diagram of the modeled flow controller which sets out elements such as: 1 – slider, 2 – piston, 3 – pin electromagnet, 4 – slot inlet, 5 – chamber of the regulator, 6 – channel 7 – slot outlet, 8 – spring.

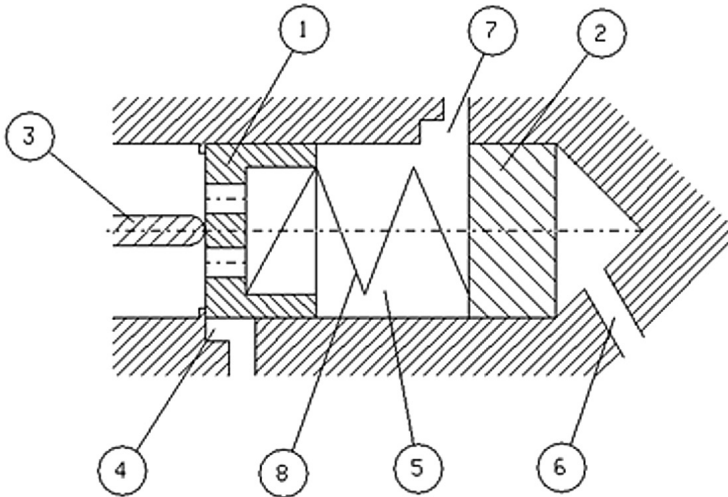

Fig. 3. Simplified schematic of the flow controller  
Rys. 3. Uproszczony schemat regulatora przepływu

The volumetric flow rate passing through the gap 4 we calculate using the formula

$$Q_R = \mu_A S_A \sqrt{\frac{2(p_z - p_{S1})}{\rho}} \quad (3)$$

where:

- $\mu_A$  – gap aspect ratio of,
- $S_A$  – cross sectional area gap 4,
- $p_z$  – pressure in the supply line,
- $p_{S1}$  – pressure in the flow controller chamber,
- $\rho$  – density of the liquid.

### Pressure in the flow controller

The pressure in the valve chamber  $p_{S1}$  describes of liquid flow balance, taking into account the compressibility

$$\frac{dp_{S1}}{dt} = (Q_R - Q_{S1}) \frac{B_z}{V_{S1}(x_s)} \quad (4)$$

where:

$V_{S1}(x_s)$  – valve chamber volume as a function of slider is moved.

### Flow controller slider and piston

On the slider  $m_s$  with a mass controller work force:

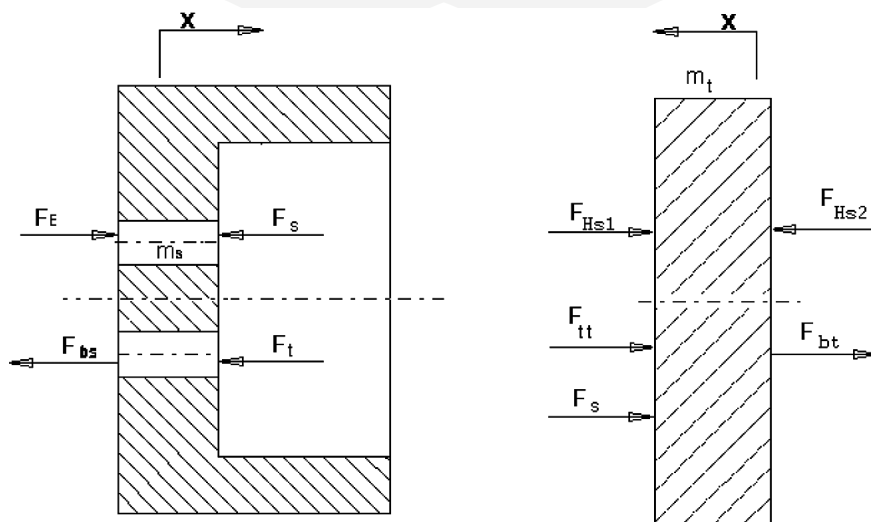

Fig. 4. Forces acting on the slider and piston controller  
Rys. 4. Siły działające na suwak oraz tłoczek regulatora

### Forces acting on the slider

Force of inertia

$$F_{bs} = m_s \frac{d^2 x_s}{dt^2} \quad (5)$$

where:

$m_s$  – mass of the slider,

$x_s$  – moving the slider.

Viscous friction force

$$F_t = f_s \frac{dx_s}{dt} \quad (6)$$

where:

$f_s$  – coefficient of resistance to motion.

The spring force

$$F_s = c(x_s + x_w + x_t) \quad (7)$$

where:

$c$  – spring constant,

$x_w$  – initial deflection,

$x_t$  – piston displacement.

Because the same pressure acts on both sides of the slider  $H_{s1}$ , hydrostatic force is balanced and does not affect system balance of forces.

### Forces acting on the piston

Force of inertia

$$F_{bt} = m_t \frac{d^2 x_t}{dt^2} \quad (8)$$

where:

$m_s$  – mass of the piston

Viscous friction force

$$F_{tt} = f_s \frac{dx_t}{dt} \quad (9)$$

The spring force

$$F_s = c(x_s + x_w + x_c) \quad (10)$$

Hydrostatic forces

$$F_{Hs1} = p_{s1} S_t \quad (11)$$

$$F_{Hs2} = p_z S_t \quad (12)$$

where:

$S_t$  – surface area of the piston,

$p_{s1}$  – pressure in the valve,

$p_z$  – supply line pressure.

### 3. Model in Matlab-Simulink

Set of equations are equations (1)–(12). To solve the equations used in the program MATLAB / Simulink. For this purpose was built block diagram which is shown in Figure 5.

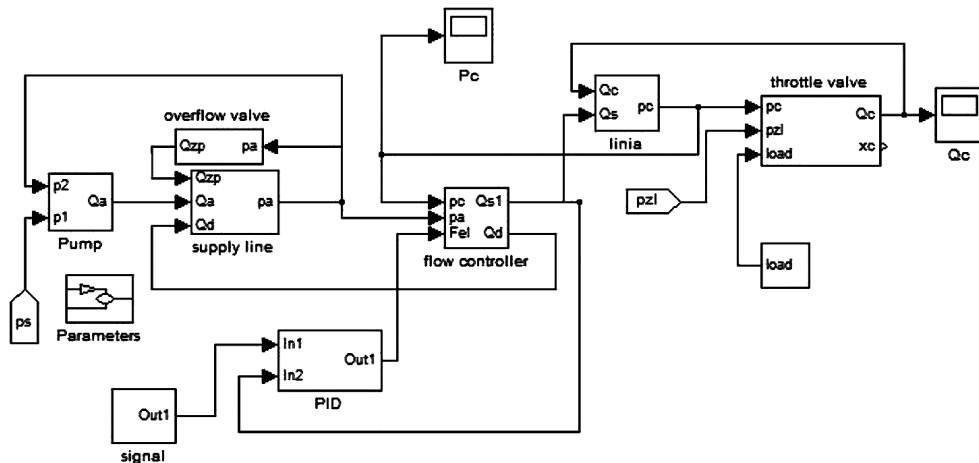

Fig. 5. Block diagram of the hydraulic system was built in Matlab - Simulink

Rys. 5. Schemat blokowy układu hydraulicznego zbudowany w Matlab-Simulink

The construction scheme uses the convention that the individual sub-blocks represent system components. In this way it is possible to easy modification and extension of system of additional elements. Figure 6 shows a simulation result in the initial stage of pump start-up until the determination of the conditions of pressure and flow.

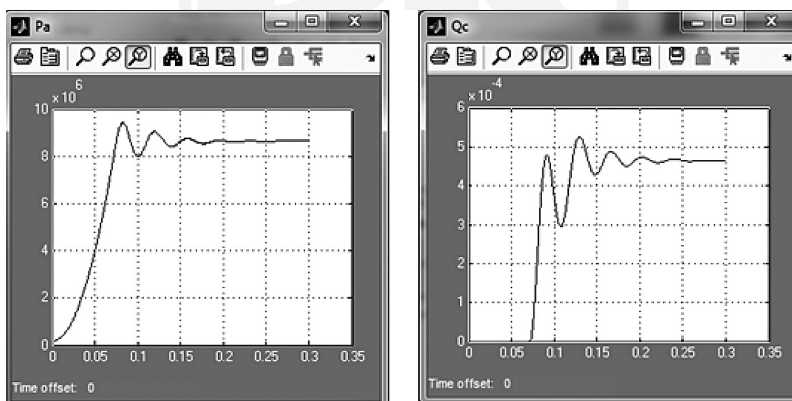

Fig. 6. Sparkline pressure  $p_a$  on input to the flow controller and course of the volumetric flow rate  $Q_c$

Rys. 6. Wykres przebiegu ciśnienia  $p_a$  na wejściu do regulatora przepływu oraz przebieg objętościowego natężenia przepływu  $Q_c$

#### 4. Conclusions

The model allows the simulation and testing of an item in a variety of configurations. Possible to use it to search for better controller of geometric parameters increase the precision control. The next step is to verify the real model of the hydraulic system, and selection of parameters of the PID controller to improve the characteristics of the valve.

#### Reference

- [1] Lisowski E., Filo G., *Zastosowanie logiki rozmytej do sterowania proporcjonalnym zaworem przelewowym*, Przegląd Mechaniczny nr 1/2002.
- [2] Filo G., Lisowski E., *Pozycjonowanie siłownika hydraulicznego przy zastosowaniu regulatorów cyfrowych*, Przegląd Mechaniczny nr 1/2006.
- [3] Lisowski E., Filo G., *Pozycjonowanie ładunku podnośnikami hydraulicznymi z regulatorami w logice rozmytej*, Hydraulika i Pneumatyka, nr 1/2010.
- [4] Brandys P., *Modelowanie synchronizatora przepływu w układzie napędowym z siłownikami hydraulicznymi*, praca doktorska, Politechnika Krakowska, Kraków 2002.

