

PIOTR BOGUSZ*, MARIUSZ KORKOSZ*, PIOTR WYGONIK**

STUDIES OF THE PERMANENT MAGNET DC MACHINE

BADANIA MASZYNY PRĄDU STAŁEGO
Z MAGNESAMI TRWAŁYMI

Abstract

A hybrid drive of an unmanned aerial vehicle uses two mechanically coupled drives. In one of the drives, an electrical machine is used. Its role is not only limited to a motoring operation, e.g. during achieving the flight ceiling. The electric machine changes its operation into generating after reaching the flight ceiling, this allows not only meeting current electrical energy demands but also battery recharging. This paper presents the results of laboratory tests of a BLDC machine in motoring and generating operation. Mechanical characteristics of the motor for different supply voltages and external characteristics for generator were determined. The possible energy conversion efficiencies for both motoring and generating operations were determined.

Keywords: BLDC machine, hybrid drive, motoring operation, generating operation

Streszczenie

Napęd hybrydowy bezałogowego aparatu latającego wykorzystuje dwa napędy sprzężone ze sobą mechanicznie. W jednym z napędów stosuje się maszynę elektryczną. Jej rola nie ogranicza się tylko do pracy silnikowej w trakcie np. osiągnięcia pułapu przelotowego. Po osiągnięciu pułapu przelotowego maszyna elektryczna przechodzi w stan pracy generatorowej, umożliwiając nie tylko pokrywanie bieżącego zapotrzebowania na energię elektryczną, ale również doładowywanie baterii akumulatorów. W niniejszym artykule przedstawiono wyniki badań laboratoryjnych maszyny prądu stałego z magnesami trwałymi w zakresie pracy silnikowej i prądnicowej. W wyniku badań wyznaczono charakterystyki mechaniczne badanej maszyny przy pracy silnikowej dla różnych napięć zasilających oraz wyznaczono charakterystyki zewnętrzne maszyny pracującej w zakresie pracy generatorowej. Określono możliwe do osiągnięcia sprawności przetwarzania energii w obu stanach pracy.

Słowa kluczowe: bezszczotkowa maszyna prądu stałego z magnesami trwałymi, napęd hybrydowy, praca silnikowa, praca generatorowa

DOI: 10.4467/2353737XCT.15.036.3836

* Ph.D. Eng. Piotr Bogusz, D.Sc. Ph.D. Eng. Mariusz Korkosz, Faculty of Electrical and Computer Engineering, Rzeszow University of Technology.

** Ph.D. Eng. Piotr Wygonik, Faculty of Mechanical Engineering and Aeronautics, Rzeszow University of Technology.

1. Introduction

Nowadays, an integral part of hybrid drives are electric machines. In many cases, these machines operate both as motors and generators. This is the specification of the hybrid drive, in which part of the kinetic energy of the vehicle is recovered during braking and is then converted into electrical energy. This energy is stored in batteries and used during acceleration or driving uphill. Intensive work on the development of hybrid drive systems used in unmanned aerial vehicles (UAVs) is currently being conducted [1–6]. In this type of drive, an electric motor operates as a motor during climbing and delivers additional power to the propeller. It can also drive the propeller alone, a so-called quiet drive. The demand for power during the flight on a specific ceiling is much smaller than when climbing. Thus, the excess of combustion engine power can be used to charge the battery through the electric machine operating as a generator. In the case of electric and hybrid drives, high efficiency at the smallest possible size is required, especially for UAV.

The aim of this paper is an evaluation of the parameters of the electric machine with permanent magnets as a hybrid drive in motoring and generating operation. The mechanical characteristics for the motoring operation and the external characteristics for the generating operation were determined. The efficiency of the machine for both states was determined.

2. Hybrid drive of the UAV

To improve the efficiency of the combustion engine in the UAV drive, a parallel hybrid drive can be used. In the case of the parallel hybrid drive, there are three options:

- drive with a common shaft,
- drive with a clutch,
- drive through the planetary gear.

The simplest solution and occupying the least amount of space is the hybrid drive with a common shaft. However, its disadvantage is a lack of independent operation of the electric motor and combustion engine. In this solution, there is no possibility of independent operation of the electric motor. The drive with the clutch, which disconnects the combustion engine from the rest of the drive, requires a precise coupling of the combustion engine and the electric motor, e.g. through an electromagnetic clutch. The solution with the planetary gear provides an independent operation of the electric motor, but requires more space and deteriorates the efficiency of the entire drive. Figure 1 shows a block diagram of an exemplary hybrid drive with a gear designed for UAVs. The laboratory test stand of the hybrid drive is shown in Fig. 2.

In the hybrid drive system, the permanent magnet DC machine (BLDCM) was used. The used construction of the BLDCM has an external rotor. This solution leads to a reduction of dimensions of the machine and provides the increased value of the produced electromagnetic torque while reducing the weight of the machine. The disadvantage of this solution is a reduced durability of the motor compared to classical solutions with inner rotor. Table 1 lists the selected geometrical dimensions and parameters of the tested machine.

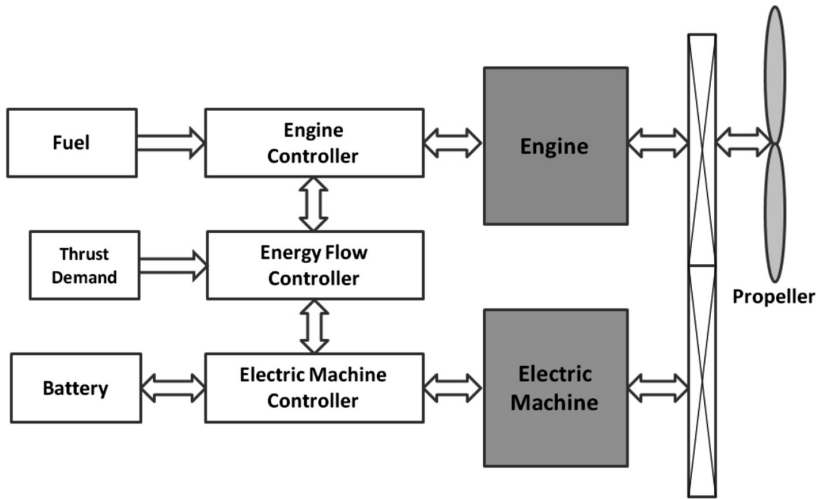

Fig. 1. Block diagram of a hybrid drive with a gear designed for UAV

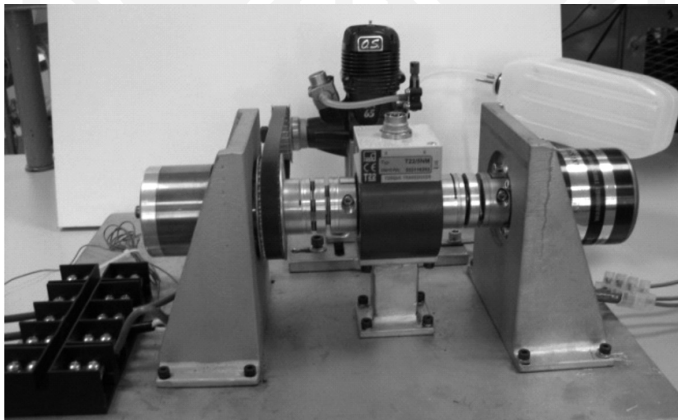

Fig. 2. Laboratory test stand of the hybrid drive

Table 1

Selected parameters and geometrical dimensions of the tested machine

Supply voltage [V]	24–42
No. of phases	3
Winding configuration	triangle
No. of stator poles	12
No. of rotor poles	14
Constant k_v [V/1,000 rpm]	5.84
Phase resistance R_{ph} [Ω]	0.042
No. of turns of winding per pole	18
Rotor outer diameter [mm]	53
Packet length of the stator [mm]	45
Permanent magnets	neodymium
Magnetic sheet of the stator	anisotropic

3. Static characteristics

3.1. Cogging torque

In the laboratory conditions, the cogging torque T_{Coog} of the BLDC machine in a function of the rotor position θ was determined (Fig. 3). Due to the anisotropy of the magnetic steel used in the magnetic circuit of the stator, the cogging torque has significant value, which varies from +0.3 Nm to -0.25 Nm. By using the anisotropy steel, the variation period of the cogging torque decreased from 84 (for the isotropy steel) to 14. The maximum value of the cogging torque also increased significantly.

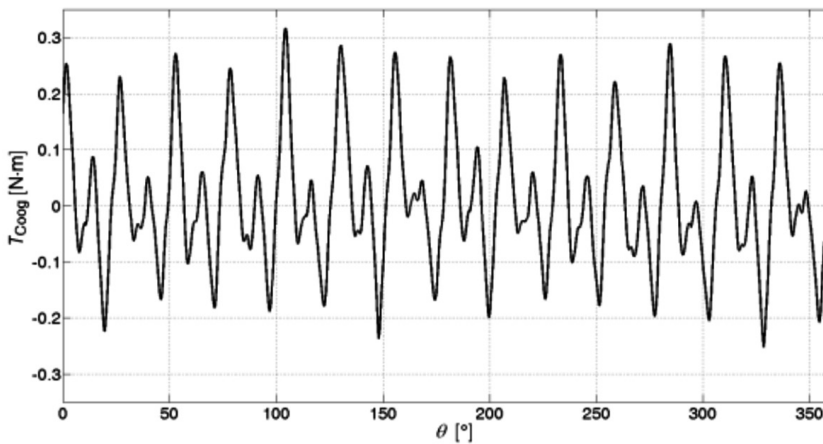

Fig. 3. Relation of cogging torque in a function of the rotor position

3.2. Electromagnetic torque

In order to determine the influence of the anisotropy of the used magnetic material on the generated torque, the measurements for three possible cases of motor phases supply, i.e. $Ph1-Ph2$, $Ph2-Ph3$ and $Ph3-Ph1$ with a constant value of current $I = 21$ A were carried out. Figure 4 shows the relationship of the electromagnetic torque T_e in a function of the rotor position θ for all three cases of motor phases supply.

The $Ph1-Ph2$ variant has the most preferred shape of the torque characteristics. Nevertheless, the torque characteristics are far from being desirable. The influence of anisotropy of the magnetic steel on the torque characteristic is quite significant. This causes significant electromagnetic torque ripples at constant value of current in the windings. In the parallel hybrid drive, it is not a significant disadvantage because the motor is directly coupled with the propeller which has a large moment of inertia. Therefore, torque ripples not only from the combustion engine, but also from the electrical motor, are compensated by the dynamic torque of the rotating propeller.

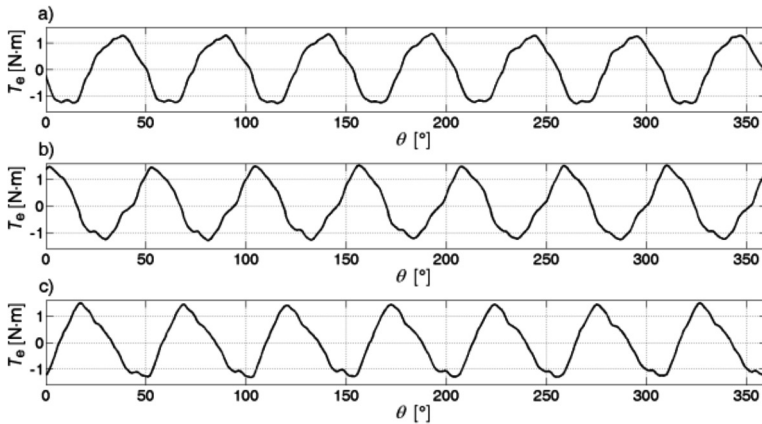

Fig. 4. Relation of the electromagnetic torque T_e in a function of the rotor position at $I = 21$ A for a) Ph1–Ph2, b) Ph2–Ph3 and c) Ph3–Ph1

4. Motoring operation

Mechanical and efficiency characteristics were determined on a laboratory test stand equipped with a stabilized DC power supply (60 V, 110 A), a power analyzer with a motor module (WT1600), a torque meter and a computer used for data acquisition. The programmable load was connected to the load machine to achieve the work with constant voltage, current and power. In the motor control system, a dedicated power supply system with a built-in algorithm of sensorless detection of the rotor position was applied.

The measurement system was configured to determine the motor efficiency, overall efficiency of the drive system or efficiency of the supply system. Particular characteristics were determined at different supply voltages. The designed drive will be powered by battery. Due to the intended application of this drive in different models of UAV, the power will be provided from lithium-polymer battery packs of 8, 9 or 10 cells. The choice will depend on the intended flight range and available space for batteries in the UAV model. Thus, studies of the drive were carried out in the voltage range from 26 V to 42 V. A block diagram of the measuring system is shown in Fig. 5.

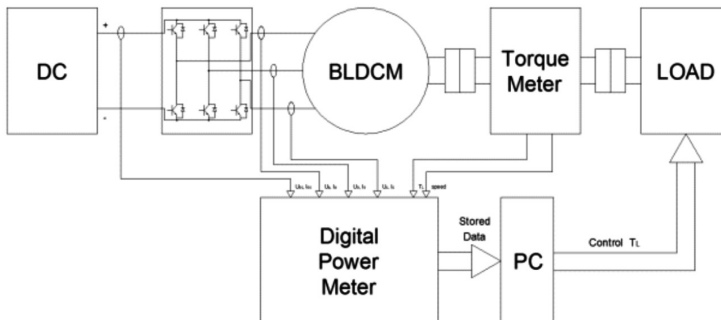

Fig. 5. Block diagram of the measuring system of BLDC machine working as a motor

The dependence of the motor speed n in a function of the load torque T_L at different supply voltages is shown in Fig. 6.

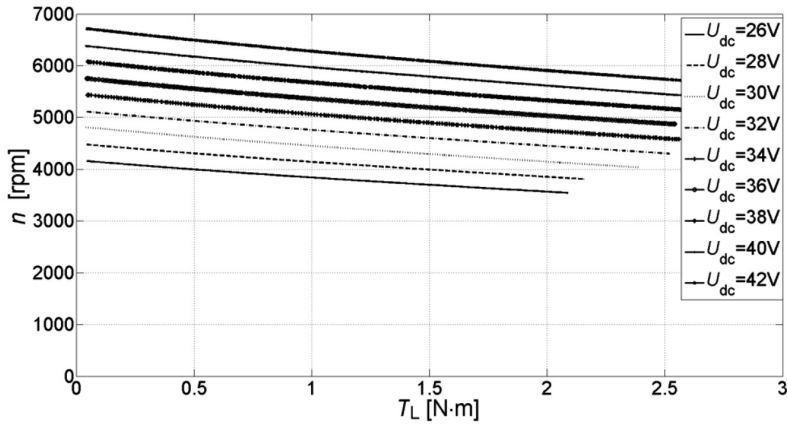

Fig. 6. The characteristics of $n = f(T_L)$ determined for different values of voltage U_{dc}

As can be seen on Fig. 6, speed decreases noticeably with increasing load torque. This results from an extensive measurement system which uses a direct measurement of all currents with the power analyzer. To measure all currents, long cables are used to connect the power analyzer with motor and control systems and to connect the power analyzer with the power supply. This solution leads to significant voltage drops in cables.

The determination of characteristics in the full range of load torque changes was precluded by acceptable parameters of the dynamometer. Below the speed of 6000 rpm, the allowable torque load had to be reduced because of the possibility of the dynamometer damage. This is evident on the obtained mechanical characteristics (Fig. 6). The relationship of the drive efficiency η in a function of the load torque T_L for the limiting voltage values is shown in Fig. 7.

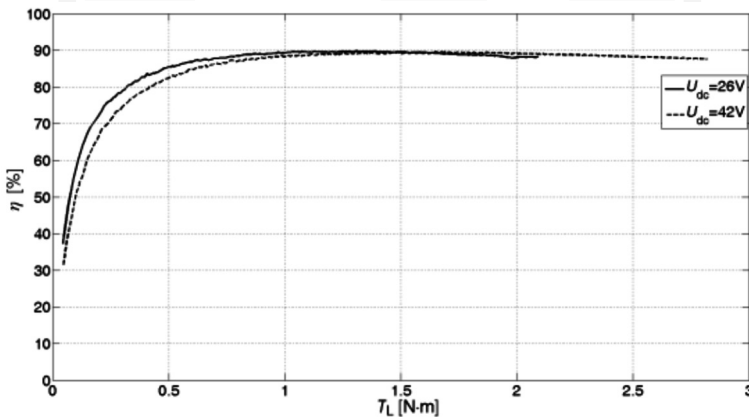

Fig. 7. Relation of the overall efficiency η in a function of the load torque T_L

The efficiency η of the tested drive system reaches 89%. The efficiency of the motor is only slightly higher (91%) due to the high efficiency of the supply system.

A slightly higher efficiency was achieved at the supply voltage $U_{dc} = 42$ V. This is natural because with the increasing supply voltage, the impact of voltage drops in power electronics components of power supply system decreases.

5. Generating operation

A block diagram of the measurement system of the generating operation is shown in Fig. 8.

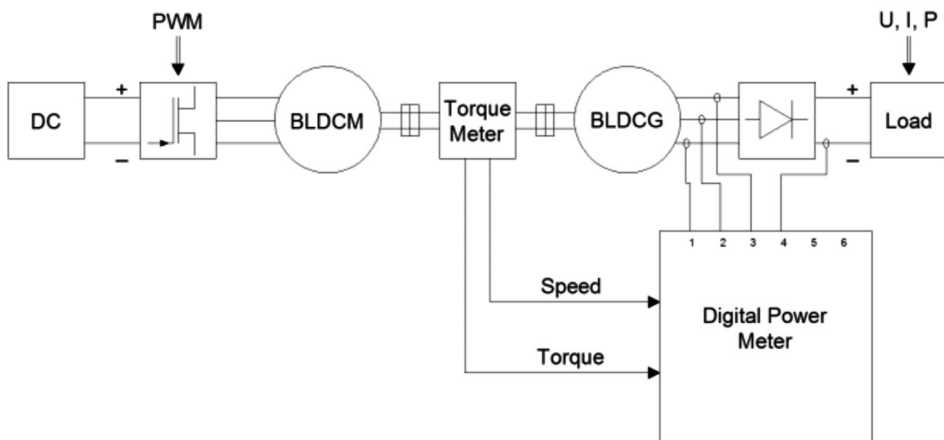

Fig. 8. The block diagram of the measurement system of the BLDC generator

Waveforms of the induced voltages were obtained without loading the tested machine. The wire induced voltages obtained at a speed $n = 3000$ rpm are shown in Fig. 9.

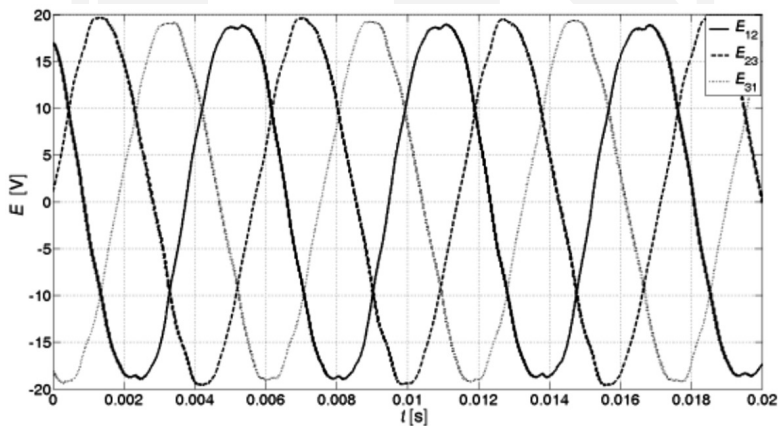

Fig. 9. Waveforms of the wire induced voltages at speed $n = 3000$ rpm

As one can see, the wire voltages and torque characteristics differ significantly from the desired waveforms. Only in the case of the wire voltage E_{12} is the obtained shape close to the trapezoidal one. Two other voltages differ significantly from the trapezoidal shape. This is the effect of the anisotropy of the used magnetic material of the stator.

The output voltage of the generator is important from the point of view of battery charging. In the laboratory conditions, the studies forcing the constant value of voltage $U_{dc} = \text{const}$ on the output of the generator through the programmable load were conducted. The load current I_{dc} (after rectifier circuit) was increasing with increases to the rotational speed. The relationship of the load current I_{dc} in a function of rotational speed n at a constant value of voltage of $U_{dc} = \text{const}$ is shown in Fig. 10.

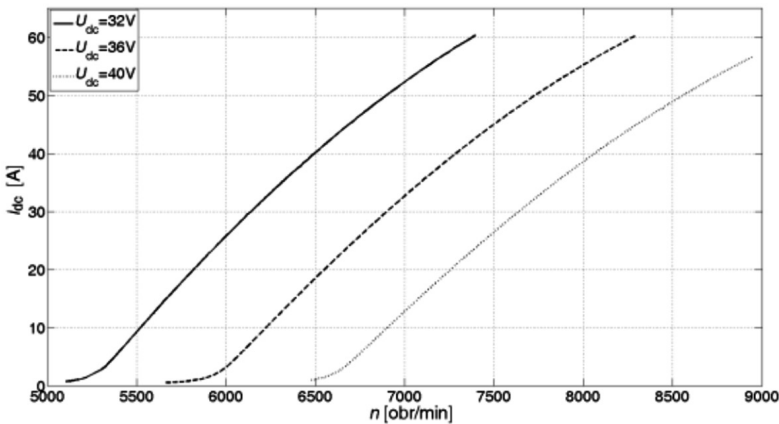

Fig. 10. Relationship of the load current of the I_{dc} generator in a function of rotational speed n at a constant output voltage $U_{dc} = \text{const}$

The control of the machine speed n is required to obtain the specified value of the load current of the generator at the given output voltage. It is easy to notice that by keeping a constant output voltage, the relationship between the I_{dc} current and the rotational speed n is not linear. The resulting efficiency η of the machine operating as a generator at a constant output voltage in a function of generator load current I_{dc} is shown in Fig. 11.

With the increase of the output voltage of the generator, the overall efficiency of the system also increases. The maximum efficiency of the generator with the rectifier system was 87.5% (generator – 91.5%). The effective operation range of the generator requires a current load no less than $I_{dc} > 10$ A. Below this value, regardless of the output voltage of the generator, the overall efficiency reduces significantly.

The obtained stiffness of the external characteristics of the machine operating as a generator is not satisfactory. With the increase of the load current there is a significant voltage drop at the rectifier terminals. Maintaining a constant voltage at the output of the rectifier requires an increase in rotational speed (Fig. 10). An overall efficiency of the machines in this state does not exceed 88% and is lower than during the motoring operation. The Li-Po cells (lithium-polymer) intended for use have significant limitations (the maximum value of charging current). Thus, the actual efficiency of the machine in the generating operation will not exceed 80% due to operation at low load current.

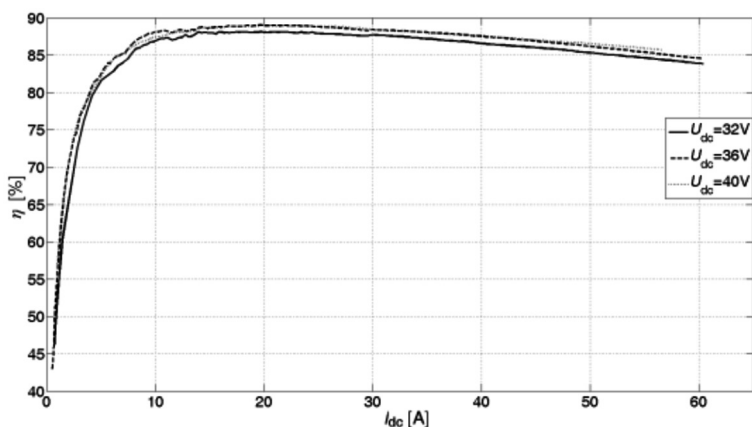

Fig. 11. Relationship of the efficiency η in a function of load current I_{dc} at a constant output voltage $U_{dc} = \text{const}$

6. Conclusions

In this paper, the results of laboratory studies of a BLDC machine in motoring and generating operation were presented. In the tested machine, an anisotropic magnetic sheet steel was used. The type of magnetic steel has an influence on the value of the generated cogging torque, shapes of torque characteristics and induced voltages. This introduces additional electromagnetic torque ripples in the tested motor. However, the resulting overall efficiency of the machine in motoring operation exceeds 89% and the motor efficiency of about 91%. In the generating operation, overall efficiency was significantly lower and does not exceed the value of 88%. The influence on the deterioration in the efficiency of the machine in the generating operation has a rectifier circuit whose efficiency decreases with the increase of the load current. The efficiency of the power system (rectifier) attached to the machine during the generating operation is a few percent lower than that of the controller attached to the machine operating as a motor, due to the fact that during the motoring operation, the MOSFET transistors have a higher efficiency compared to the rectifier diodes, which operate at the generating operation. If the machine works as a generator intended for UAV, the goal working point of the drive should be considered. In this state, the output voltage of the rectifier circuit should not be less than the maximum voltage of battery. Only then is it possible that the batteries can be fully recharged.

References

- [1] Hodkinson R., Fenton J., *Lightweight Electric/Hybrid Vehicle Design*, Reed Educational and Professional Publishing Ltd, 2001.
- [2] Gawale A., Pant R., *Paper 2004-01-design studies of power plant system of non-rigid airships*, Aerosp. Eng. Dept., Indian Inst. Technol. Bombay, Mumbai, India 2004.

- [3] Glasscock R., Hung J.Y., Gonzalez L.F., Walker R.A., *Multimodal hybrid powerplant for unmanned aerial systems (UAS) Robotics*, Twenty-Fourth Bristol International Unmanned Air Vehicle Systems Conference, March 30th to April 1st 2009, Bristol, United Kingdom.
- [4] Gaide D., Humbargar C., Larrabee D., Marshman J., Petersen E., Serani E., Wormer E., *Hybrid electric integrated optimized system (helios); design of a hybrid propulsion system for aircraft*, Univ. Colorado, Boulder, CO, USA, Tech. Rep. AIAA 900675, 2011.
- [5] Recoskie S., Fahim A., Gueaieb W., Lanteigne E., *Experimental testing of a hybrid power plant for a dirigible UAV*, J. Intell. Robot. Syst., 2012, Vol. 9764, pp. 69–81.
- [6] Recoskie S., Fahim A., Gueaieb W., Lanteigne E., *Hybrid Power Plant Design for a Long-Range Dirigible UAV*, Mechatronics, IEEE/ASME Transactions, 2014, Vol. 19, Issue 2, pp. 606–614.

Additional information:

The work done within the research project ‘Technologies of hybrid power drive of light or unmanned aerial vehicles’ – DZP/INNOLOT-1/2020/2013.

