



Missouri University of Science and Technology  
Scholars' Mine

---

Materials Science and Engineering Faculty  
Research & Creative Works

Materials Science and Engineering

---

01 Mar 2014

## Corrosion-Resistant Glasses for Steel Enamels

Richard K. Brow

*Missouri University of Science and Technology, brow@mst.edu*

Signo Tadeu Dos Reis

*Missouri University of Science and Technology*

Michael L. Koenigstein

Genda Chen

*Missouri University of Science and Technology, gchen@mst.edu*

Follow this and additional works at: [https://scholarsmine.mst.edu/matsci\\_eng\\_facwork](https://scholarsmine.mst.edu/matsci_eng_facwork)



Part of the [Materials Science and Engineering Commons](#), and the [Structural Engineering Commons](#)

---

### Recommended Citation

R. K. Brow et al., "Corrosion-Resistant Glasses for Steel Enamels," *U.S. Patents*, Mar 2014.

This Patent is brought to you for free and open access by Scholars' Mine. It has been accepted for inclusion in Materials Science and Engineering Faculty Research & Creative Works by an authorized administrator of Scholars' Mine. This work is protected by U. S. Copyright Law. Unauthorized use including reproduction for redistribution requires the permission of the copyright holder. For more information, please contact [scholarsmine@mst.edu](mailto:scholarsmine@mst.edu).



US008679389B2

(12) **United States Patent**  
**Brow et al.**

(10) **Patent No.:** **US 8,679,389 B2**  
(45) **Date of Patent:** **Mar. 25, 2014**

(54) **CORROSION-RESISTANT GLASSES FOR STEEL ENAMELS**

(76) Inventors: **Richard K Brow**, Rolla, MO (US);  
**Signo T. Reis**, Rolla, MO (US); **Mike Konigstein**, Columbia, MO (US);  
**Genda Chen**, Rolla, MO (US)

(\* ) Notice: Subject to any disclaimer, the term of this patent is extended or adjusted under 35 U.S.C. 154(b) by 273 days.

(21) Appl. No.: **13/040,781**

(22) Filed: **Mar. 4, 2011**

(65) **Prior Publication Data**  
US 2012/0164340 A1 Jun. 28, 2012

**Related U.S. Application Data**  
(62) Division of application No. 12/623,236, filed on Nov. 20, 2009, now Pat. No. 7,901,769.  
(60) Provisional application No. 61/199,901, filed on Nov. 21, 2008.

(51) **Int. Cl.**  
**B05D 7/14** (2006.01)  
(52) **U.S. Cl.**  
USPC ..... **264/135**  
(58) **Field of Classification Search**  
USPC ..... 264/135  
See application file for complete search history.

(56) **References Cited**

U.S. PATENT DOCUMENTS

6,001,494 A \* 12/1999 Kuchinski et al. .... 428/653  
2007/0264527 A1\* 11/2007 Sykes et al. .... 428/702  
2009/0155118 A1\* 6/2009 Kan et al. .... 420/91

\* cited by examiner

*Primary Examiner* — Larry Thrower  
*Assistant Examiner* — Xue Liu

(74) *Attorney, Agent, or Firm* — C. John Brannon; Brannon Sowers & Cracraft PC

(57) **ABSTRACT**

A cementitious composite material wherein glass-coated steel rods are positioned in a cementitious matrix. The glass composition for coating the steel reinforcing rods includes between about 33-45 weight percent SiO<sub>2</sub>, 13.5-19.5 weight percent B<sub>2</sub>O<sub>3</sub>, 3.5-4.6 weight percent Al<sub>2</sub>O<sub>3</sub>, 4.0-13.5 weight percent K<sub>2</sub>O, 5.5-15.5 weight percent ZrO<sub>2</sub>, 8.6-15.9 weight percent Na<sub>2</sub>O, 4.6-5.1 weight percent CaO, 0.6-0.7 weight percent MnO<sub>2</sub>, 1.0-1.0 weight percent NiO, and 1.0-1.1 weight percent CoO. The glass composition is typically in compression on the rods at ambient temperatures, has a coefficient of thermal expansion of between about 12.5 and about 13.5, and has a softening temperature of between about 585 degrees Celsius and about 600 degrees Celsius.

**18 Claims, 6 Drawing Sheets**

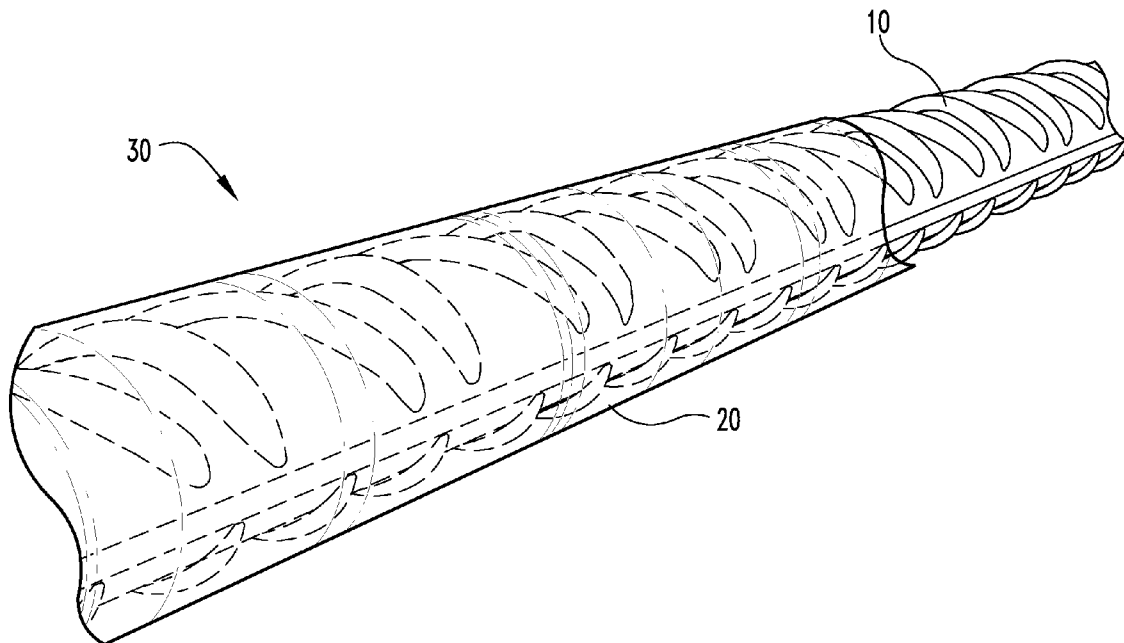

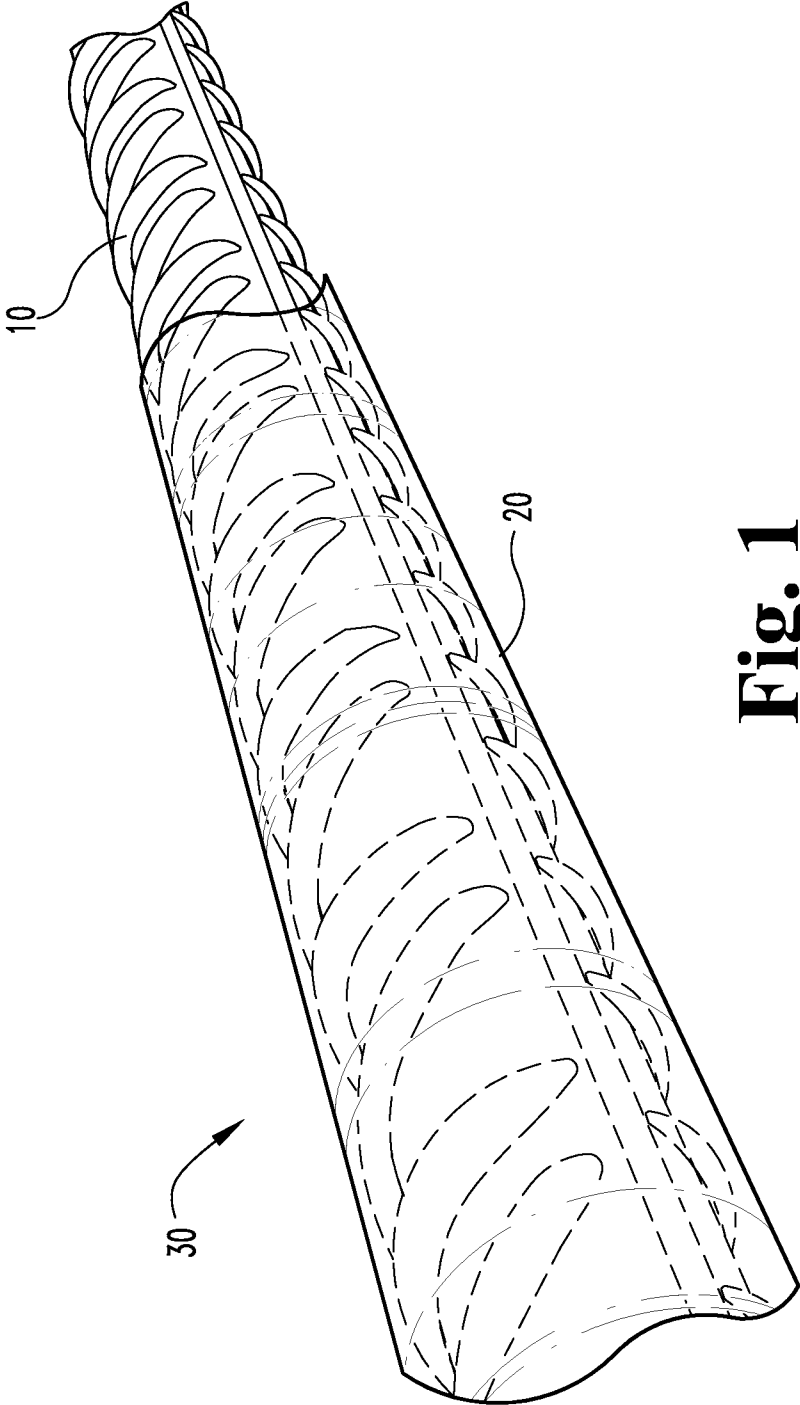

**Fig. 1**

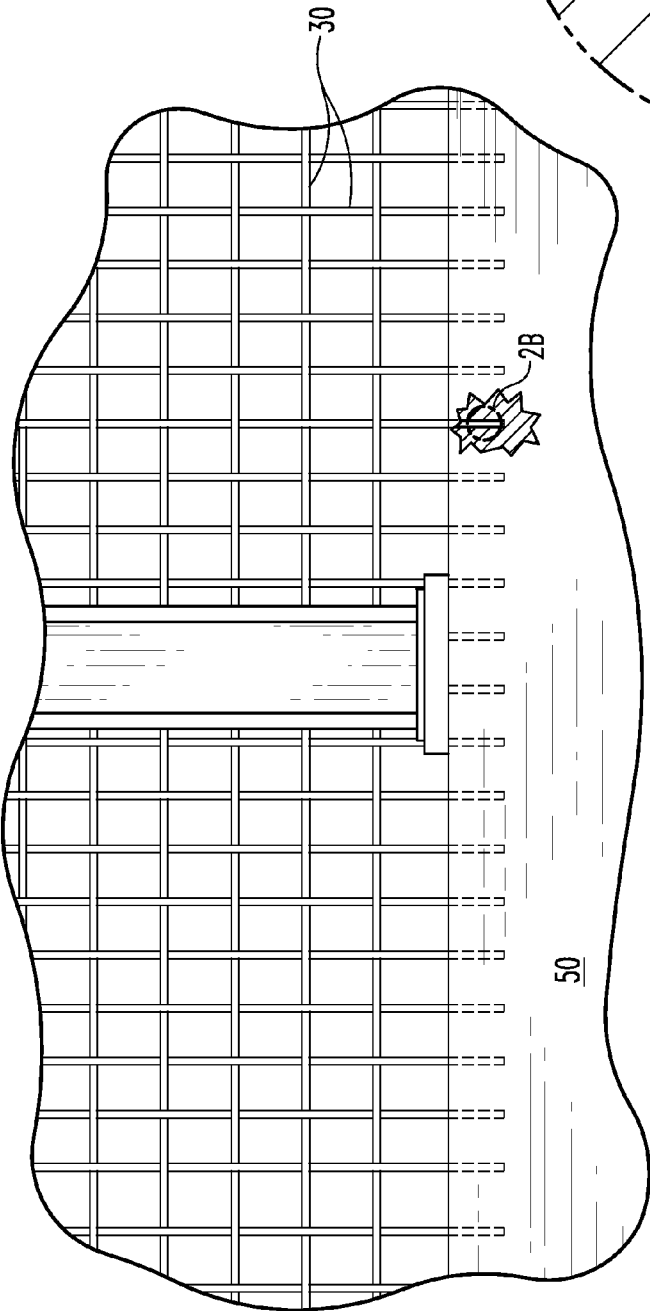

Fig. 2A

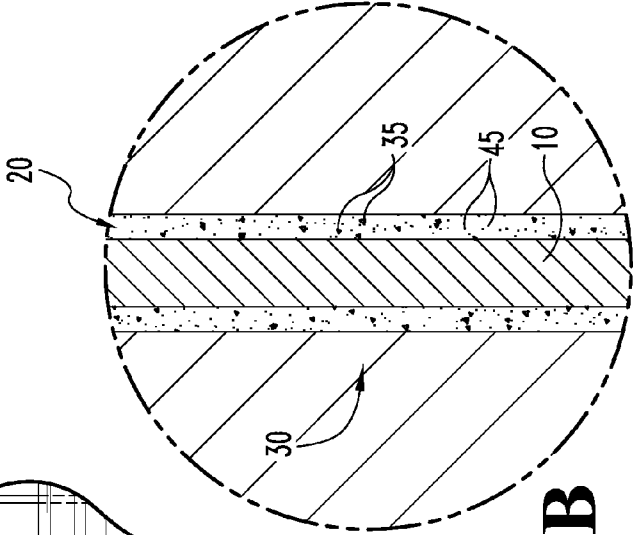

Fig. 2B

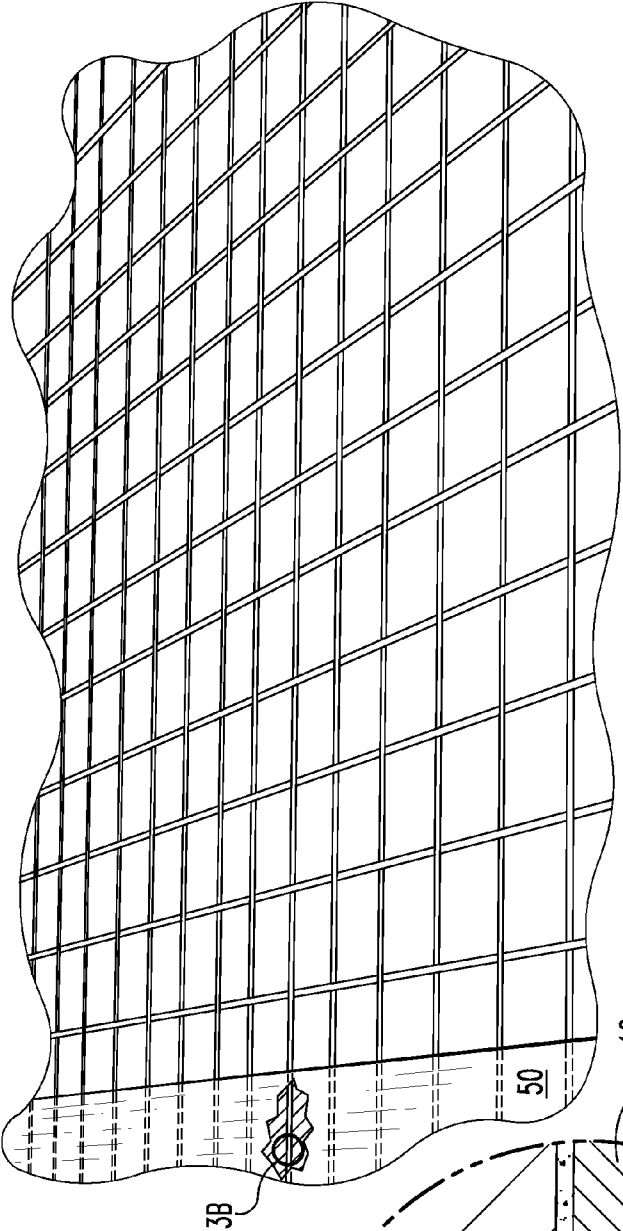

Fig. 3A

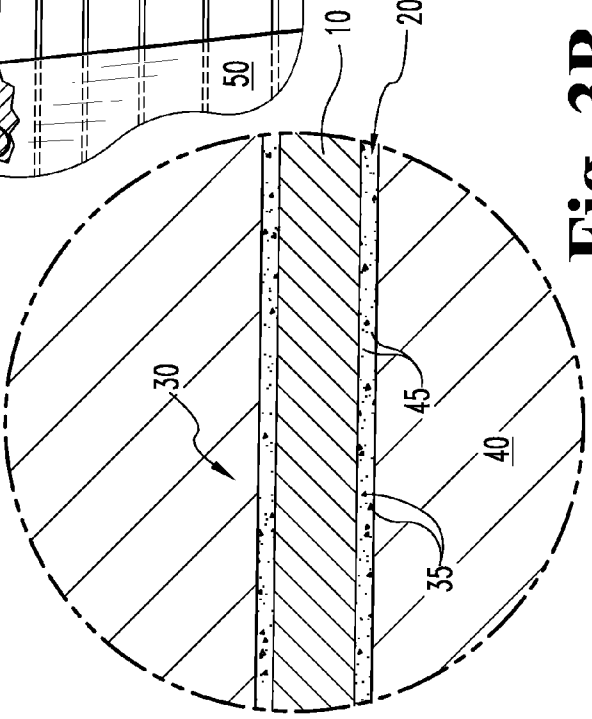

Fig. 3B

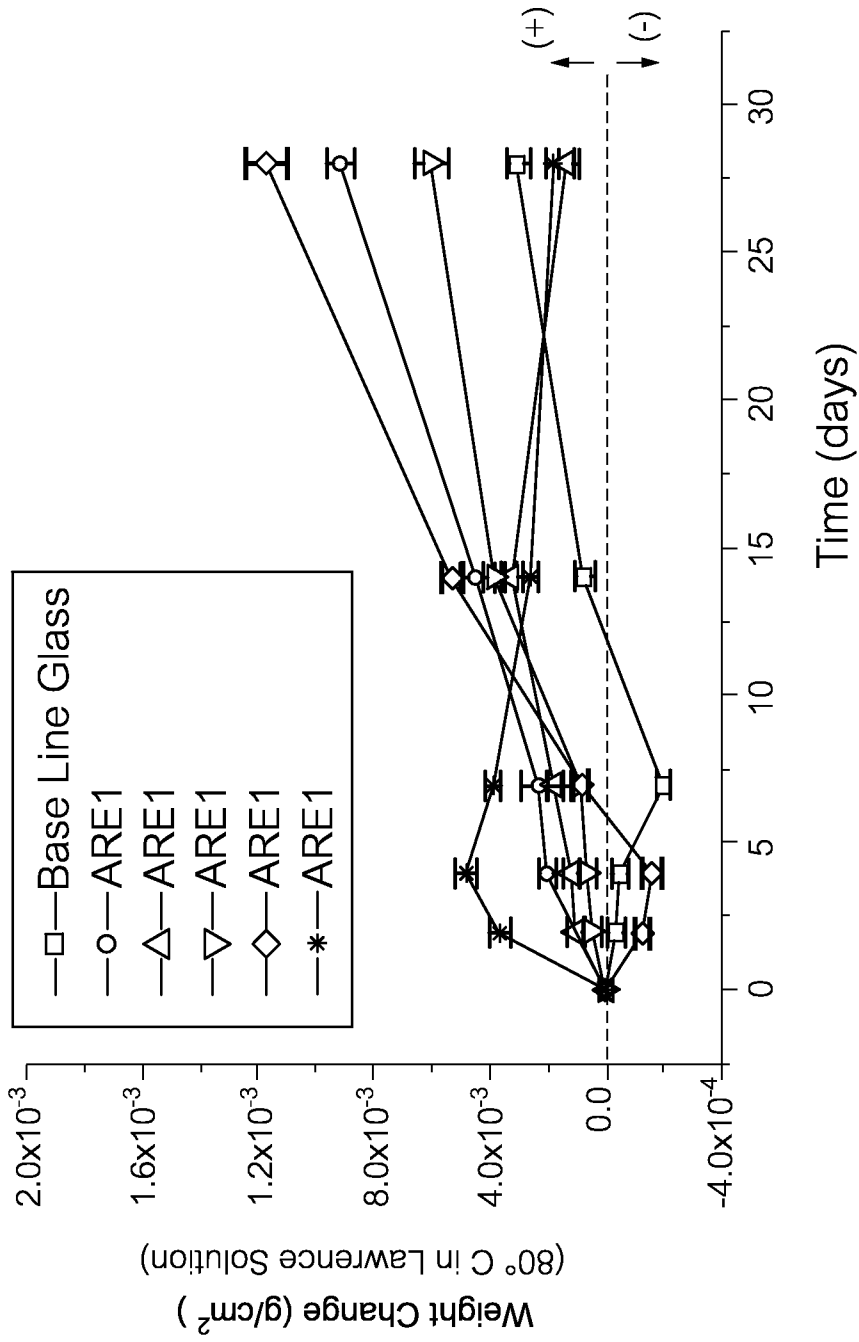
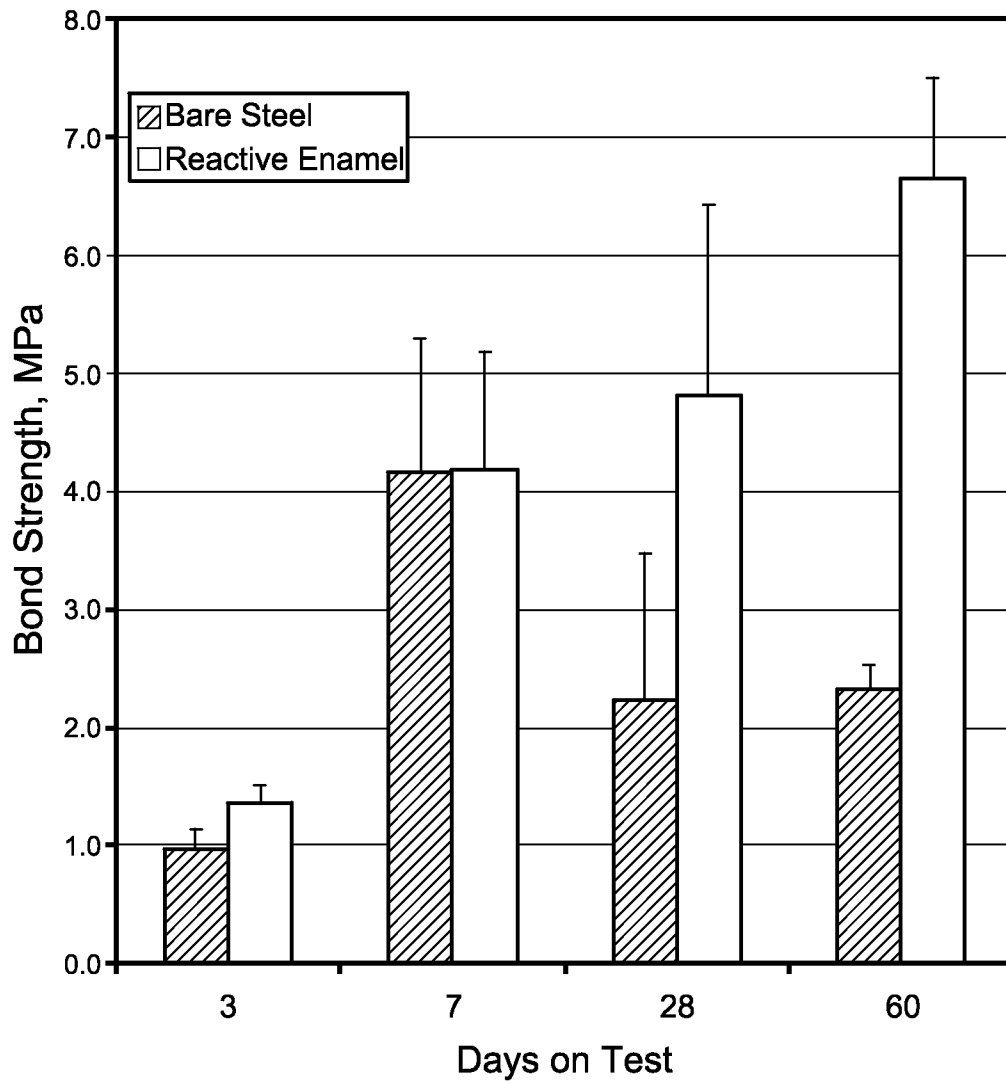
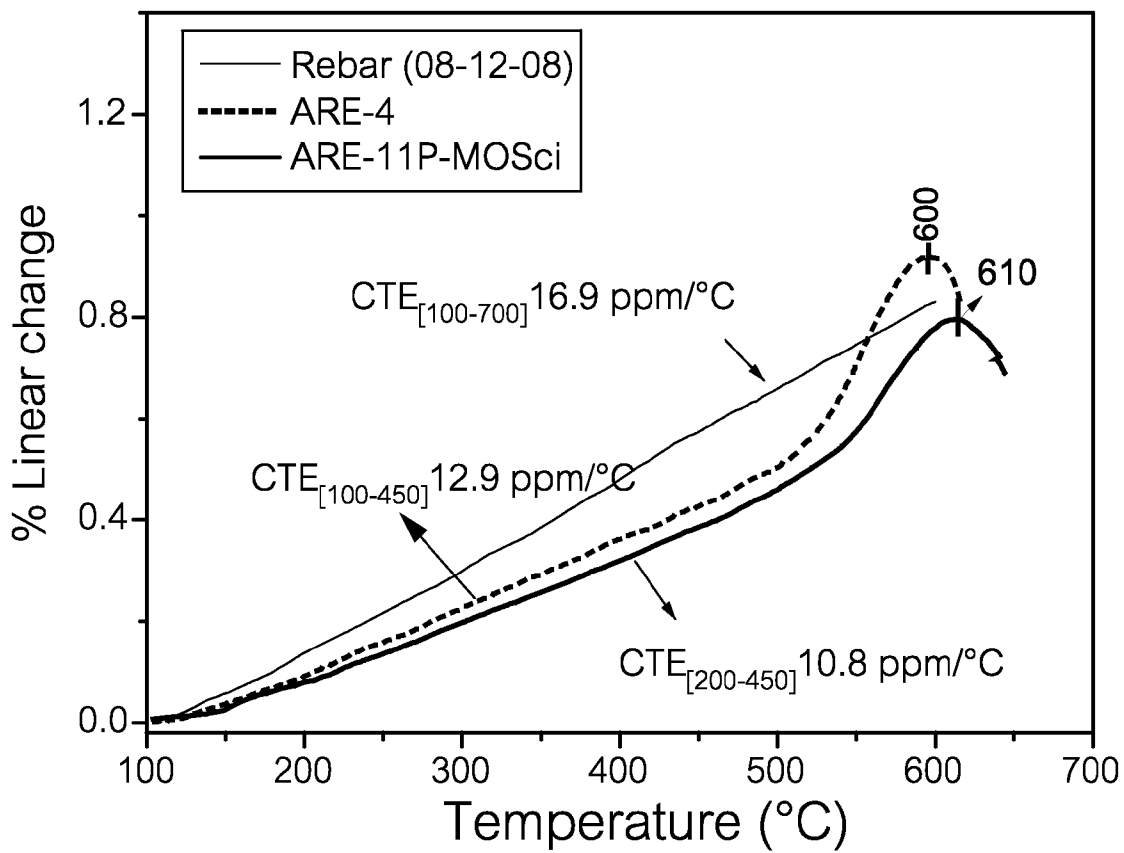

Fig. 4



**Fig. 5**

### Are11P : Dilatometric Analysis



**Fig. 6**



## CORROSION-RESISTANT GLASSES FOR STEEL ENAMELS

### CROSS-REFERENCE TO RELATED APPLICATIONS

This patent application claims priority to co-pending U.S. patent application Ser. No. 12/623,236, filed on Nov. 20, 2009, which claimed priority to then U.S. Provisional Patent Application Ser. No. 61/199,901, filed Nov. 21, 2008.

### GRANT STATEMENT

The invention was made in part from government support under Grant No. W911NF-07-2-0062 from the Department of the Army. The U.S. Government has certain rights in the invention.

### TECHNICAL FIELD

The present invention relates to structural materials and, more particularly, to a new and improved glass composite developed for coating steel elements for reinforcing concrete structures.

### BACKGROUND

One material very commonly selected for large-scale construction projects is reinforced concrete (RC). Several years ago, the Army Corps of Engineers discovered that the use of a modified vitreous enamel improved the bond strength, and, possibly, the corrosion resistance of the steel rods reinforcing the concrete. The enamel consisted of a glass matrix embedded with reactive ceramic particles. The glass composition was designed to strongly adhere to the steel, and the reactive particles were imbedded to chemically react with the surrounding cement to form another strong bond.

The materials used for these initial tests included commercial alkali-resistant groundcoat enamels for steels used in a variety of consumer and industrial applications. The typical compositional ranges for such enamels are summarized below as Table 1.

TABLE 1

Compositional ranges for typical alkali-resistant groundcoats	
Constituent	Range (wt %)
Silicon dioxide SiO <sub>2</sub>	40-45
Boron oxide B <sub>2</sub> O <sub>3</sub>	16-20
Na oxide Na <sub>2</sub> O	15-18
K oxide K <sub>2</sub> O	2-4
Li oxide Li <sub>2</sub> O	1-2
Ca oxide CaO	3-5
Aluminum oxide Al <sub>2</sub> O <sub>3</sub>	3-5
Zr oxide ZrO <sub>2</sub>	4-6
Mn dioxide MnO <sub>2</sub>	1-2
Ni oxide NiO	1-2
Cobalt oxide Co <sub>3</sub> O <sub>4</sub>	0.5-1.5
Phosphorus oxide P <sub>2</sub> O <sub>5</sub>	0.5-1

The ratio of the Na<sub>2</sub>O, B<sub>2</sub>O<sub>3</sub>, and SiO<sub>2</sub> components, as well as the addition of other alkali (K<sub>2</sub>O and Li<sub>2</sub>O) and alkaline earth oxides (CaO), have the greatest effect on the thermal properties of the glass. Constituents like Al<sub>2</sub>O<sub>3</sub> are added to improve the corrosion-resistance of the glass. ZrO<sub>2</sub> (and P<sub>2</sub>O<sub>5</sub>) is usually added to an enamel as an opacifier to affect the visual appearance of the coating. However, zirconia has the added advantage of improving the chemical resistance of

silicate glasses to attack by alkaline environments. Alkaline-resistant silicate glass fibers developed for reinforcing cement composites typically contain 10-20 wt % ZrO<sub>2</sub>, and a protective coating of Zr-oxyhydroxide forms on the glass surface when exposed to an alkaline environment, further impeding corrosion. Transition metal oxides, like MnO<sub>2</sub>, CO<sub>3</sub>O<sub>4</sub>, and NiO, are added to enamels to aid bonding to the substrate.

In general, these materials are sodium-borosilicate glasses modified with various constituents to tailor thermal and chemical properties. However, the conventional groundcoat enamels (such as the ones listed in Table 1) are designed with thermal properties tailored for the steel alloys used in commercial and industrial applications. Therefore, there is a need to provide a new and improved glass composite having physical and chemical properties specifically suited for coating the reinforcing steel used in RC structures, specifically with thermal properties tailored for steel alloys used in RC structures and with chemical properties designed for alkaline cement environments. There is likewise a need for reinforcing steel members having corrosion resistant coatings better matched to the physical properties of the underlying steel so as to better adhere thereto. Finally, there remains a need for an improved steel-concrete composite material wherein the steel phase is more securely bonded within the concrete matrix phase to yield a tougher composite material. The present novel technology addresses these needs.

### SUMMARY

The present novel technology relates to a glass composition having thermal expansion and corrosion resistance desirable for coating steel rods used in RC concrete applications. The glass composition for coating steel reinforcing rods typically includes SiO<sub>2</sub> present in between about 33 and about 45 weight percent; B<sub>2</sub>O<sub>3</sub> present in between about 13.5 and about 19.5 weight percent; Al<sub>2</sub>O<sub>3</sub> present in between about 3.5 and about 4.6 weight percent; K<sub>2</sub>O present in between about 4.0 and about 13.5 weight percent; ZrO<sub>2</sub> present in between about 5.5 and about 15.5 weight percent; Na<sub>2</sub>O present in between about 8.6 and 15.9 weight percent; CaO present in between about 4.6 and about 5.1 weight percent; MnO<sub>2</sub> present in between about 0.6 and about 0.7 weight percent; NiO present in between about 1.0 and about 1.1 weight percent; and CoO present in between about 1.0 and about 1.1 weight percent. The glass composition has a coefficient of thermal expansion of between about 12.5 and about 13.5 and has a softening temperature of between about 585 degrees Celsius and about 600 degrees Celsius.

One object of the present novel technology is to provide an improved steel reinforced concrete system including the same. Related objects and advantages of the present novel technology will be apparent from the following description.

### BRIEF DESCRIPTION OF DRAWINGS

FIG. 1 is a cutaway perspective view of a steel rod coated with a vitreous material according to a first embodiment of the present novel technology.

FIG. 2A is a perspective view of a first plurality of steel rods according to FIG. 1 embedded in a cementitious material to yield a first composite material according to a second embodiment of the present novel technology.

FIG. 2B is an enlarged partial view of one of the embedded rods of FIG. 2A.

FIG. 3A is a perspective view of a second plurality of steel rods according to FIG. 1 embedded in a cementitious material

to yield a second composite material according to a second embodiment of the present novel technology.

FIG. 3B is an enlarged partial view of one of the embedded rods of FIG. 2A.

FIG. 4 shows weight changes for glasses after up to 28 days in alkaline Lawrence Solution at 80° C.

FIG. 5 shows the comparisons of average bond strengths (in MPa) for steel pins embedded in mortar after up to 60 days.

FIG. 6 is a graphical representation of the change in linear dimension vs. temperature of a steel rod and two vitreous coating compositions for the coated steel rods of FIG. 1.

#### DETAILED DESCRIPTION

For the purposes of promoting an understanding of the principles of the novel technology and presenting its currently understood best mode of operation, reference will now be made to the embodiments illustrated in the drawings and specific language will be used to describe the same. It will nevertheless be understood that no limitation of the scope of the novel technology is thereby intended, with such alterations and further modifications in the illustrated device and such further applications of the principles of the novel technology as illustrated therein being contemplated as would normally occur to one skilled in the art to which the novel technology relates.

Unless otherwise defined, all technical and scientific terms used herein have the same meaning as commonly understood by one of ordinary skill in the art to which this invention belongs.

In one embodiment, steel reinforcing rods **10** are coated with the novel glass composition **20** to yield coated reinforcing rods **30**. The glass coating **20** is particularly suitable for coating the steel alloys used in the rods **10**, as the glass coating **20** typically has a coefficient of thermal expansion close to but lower than that of the steel rods **10**, such that the glass coating **20** is maintained in compression. Further, the glass coating **20** is substantially more corrosion resistant than the conventional enamel coatings known in the art. Specifically, the thermal properties of the glass coatings are tailored for the steel alloys used in RC structures, which have different thermal expansion coefficients than the alloys used in commercial and industrial applications for which the conventional groundcoat compositions were designed. Typically, the steel alloys used in the rods **10** are ASTM A 615, 706, 955, 996 or the like, which typically have thermal expansion coefficients of from about 14 ppm/° C. to about 17 ppm/° C. The glass coating **20** typically has a thermal expansion coefficient of between about 12.5 ppm/° C. and about 13.5 ppm/° C. at ambient temperatures.

In particular, the borate-to-silicate ratio and the fraction and type of alkali oxide of the coatings **20** has been optimized to yield coatings **20** characterized by greater CTE to improve the thermomechanical compatibility with typical reinforcing steel. In other words, the CTE of the glass coatings **20** has been raised to be closer to that of typical steel rebars **10** while remaining slightly lower than the steel CTE, such that the glass coating **20** is put into compression **20** but not so much so that it fails and disengages therefrom. Further, this CTE matching was accomplished without sacrificing chemical durability of the glass coating **20**. Thus, by better matching the thermomechanical properties of the glass coatings **20** to the steel members **10**, the glass coatings **20** are less prone to failure due to stresses arising from thermal cycling and thus remain on the steel members **10** where they can participate in the bonding process with a surrounding cementitious matrix material.

Additionally, the corrosion resistance of the glass coatings **20** is especially attractive in alkaline environments. The glass coatings **20** typically includes substantially increased concentrations of CaO, K<sub>2</sub>O and, more typically, ZrO<sub>2</sub> at levels substantially greater than the typical enamel compositional ranges to provide increased corrosion resistance of the glass coated rods **30** in alkaline environments.

In some embodiments, as seen in FIGS. 2A-3B, cement-reactive particles **35**, such as calcium silicate, are dispersed in the glass coatings **20** to enhance bonding with a cement matrix **40** to result in a steel-reinforced concrete composite material **50** having increased bond strength between the coated rods **30** and the cement matrix **40**. Such a material **50** will exhibit a substantially increased pull-out strength and be inherently tougher. Alternately (or additionally), metal particles **45** such as zinc may be dispersed in the glass coating **20** to act as sacrificial anodes for further protecting the steel rods **30** from the corrosive effects of the cementitious matrix **40**. Still alternately, such sacrificial anode particles **45** may be added directly to the cement, either throughout or preferentially near the steel rods **10**, to react locally with the corrosive cementitious matrix **40** to divert its attack on the steel rods **10**. As they are corroded, the sacrificial metal particles **45** will expand to provide both physical as well as chemical protection, chemically reacting with corrosives and physically blocking the corrosion pathways.

Table 2 shows the compositions of several embodiments of the glass coating **20**, along with test results of the dilatometric softening point and the CTE, designated ARE-1 through ARE-5. For comparison, the composition and properties of a standard (conventional) alkali-resistant groundcoat composition is presented and designated ARG.

TABLE 2

Comparison between the novel glass coating compositions and ARG							
wt %	ARE-1	ARE-2	ARE-3	ARE-4	ARE-5	ARE-11	ARG
SiO <sub>2</sub>	44.5	43.4	39.7	42.0	33.2	39.3	44.0
B <sub>2</sub> O <sub>3</sub>	17.9	14.4	14.0	13.9	19.2	13.0	19.3
Na <sub>2</sub> O	15.9	15.5	15.1	8.9	8.6	8.3	15.8
K <sub>2</sub> O	4.3	4.2	4.1	13.5	13.0	12.6	2.8
CaO	5.1	5.0	4.8	4.8	4.6	4.5	4.7 CaF <sub>2</sub>
Al <sub>2</sub> O <sub>3</sub>	3.6	3.8	3.7	3.6	3.5	3.4	4.6
ZrO <sub>2</sub>	5.6	10.9	10.6	10.6	15.3	9.9	5.3
MnO <sub>2</sub>	0.7	0.6	0.6	0.6	0.6	0.6	1.5
NiO	1.1	1.1	1.1	1.1	1.0	1.0	1.0
CoO	1.1	1.1	1.1	1.1	1.0	1.0	0.9
P <sub>2</sub> O <sub>5</sub>	0	0	0	0	0	6.4	

TABLE 2-continued

Comparison between the novel glass coating compositions and ARG							
wt %	ARE-1	ARE-2	ARE-3	ARE-4	ARE-5	ARE-11	ARG
Soft Temp (° C.)	600	586	600	600	594	610	576
CTE (ppm/° C.)	13.5	12.9	12.5	12.9	12.7	10.8	12.2

FIG. 4 shows the change in weight for glass samples after up to 28 days at 80° C. in Lawrence solution (pH=13). The K<sub>2</sub>O and ZrO<sub>2</sub> contents of the ARE-series glass coatings **20** are each, respectively, greater than those of the ARG composition, and the weight changes of ARE compositions 2 and 5 are respectively less than that of the ARG glass.

In another embodiment, reinforced concrete **50** was prepared by the pouring wet concrete over coated rods **30** and allowing the concrete to dry and cure to define a concrete matrix **40**, yielding a reinforced concrete composite material **50**. The bonding of the coated rods **30** in the concrete matrix **40** was analytically measured.

A series of pull-out tests was conducted to assess the bond strengths of the embedded coated rods **30** with several compositional embodiments of the glass coating material **20**. The results of pull-out testing are shown in FIG. 5.

#### Preparation of Test Mortar.

Uncoated steel rods **10** and coated rods **30** were embedded in a mortar prepared using the guidelines presented in ASTM C109, Standard Method for Determining Compressive Strength of Hydraulic Mortars. The proportion of the standard mortar was one part cement (Type I) to 2.75 parts of standard graded sand. The water-to-cement ratio was maintained at 0.485. Test cylinders were prepared for each mortar batch and tested to investigate the compressive strength at 7 and 30 days.

#### Preparation and Testing of Embedded Rods for Pull-Out Testing.

Each uncoated **10** and glass coated test rod **30** was inserted in a 50.8-mm in diameter, 101.6-mm long plastic cylinder mold filled with fresh mortar. The respective rods **10**, **30** were clamped at the top so that a 63.5-mm length of each respective rod **10**, **30** was under the mortar; for the coated rods **30**, the portion under mortar was glass coated. Each cylinder was tapped and vibrated to remove entrapped air and also to consolidate the mortar. The samples were kept in a 100% humidity environment at room temperature and cured, with curing times ranging from 7 days and to 60 days. After curing, the test cylinders were de-molded and the mounted in the test apparatus and the force required to pull each respective rod **10**, **30** out of the mortar was measured using an Instron Model 4469 Universal Testing Machine.

The testing pin-pull results for steel after up to 60 days in mortar indicate that the bond strength of the uncoated pins decreases from about 4 MPa to about 2.2 MPa between seven days and 28 days of curing. This is consistent with reports in the literature for decreasing bond strength between cement paste and reinforcing steel with increasing curing time age, particularly from 1 to 14 days. However, due the hydration reaction of cement with the reactive Ca-silicate particles used for the glass coated samples **30**, these bond strengths increase from 1.2 MPa to 6.60 kPa with an increase of curing time from three days to 60 days. Further, glass coated steel pins **30** with reactive calcium silicate have about three times the bond strength of bare steel pins after 60 days in cement.

Steel-reinforced concrete composite material **50** benefiting from increased bond strength and decreased degradation of the steel **10** from corrosive attack by the concrete matrix **40**

give rise to a number of uses, such a structural material for floors and decking, hardened or reinforced civilian and military structures, sewage pipe, geotechnical anchorages, and the like. Further, the strong bond formed between the glass-coated steel **30** (with or without calcium silicate particles or the like dispersed therein as bonding enhancers) and the cementitious material **40** enables design options such as concrete-filled steel tubes or casings.

Further, the glass composition may be optimized to be self-sealing. As the glasses have relatively low softening temperatures, they are well suited for low temperature applications, such as retrofit and remediation applications. Additionally, glass-tape composites may be made with these compositions that may be wrapped around steel members and then fused thereto via the direct application of heat, such as by induction or a torch, to provide corrosion protection and/or an enhanced bonding surface.

Referring to FIG. 6, the change in linear dimension as a function of time is plotted for both a steel rod **10** and for two coating compositions (ARE-4 and ARE-11P). The rod **10** has a measured CTE of 16.9 ppm/° C., while the ARE-4 composition has a CTE of 12.9 ppm/° C. and the ARE-11P has a CTE of 10.8 ppm/° C. The CTE of the rod **10** is substantially constant over a temperature range of about 100 to about 700 degrees Celsius, while the CTE's of the glass coating compositions are substantially constant over ranges of between about 200 to about 450 degrees Celsius. Both compositions appear to begin to soften at about 500 degrees Celsius, resulting in a change in CTE in the 500 to 600 degree Celsius range.

The desired properties of the novel glass composite include 1) a coefficient of thermal expansion (CTE) that is more compatible with the steel alloy that is to be coated, 2) a softening temperature that is relatively low (<700° C.) to ensure low processing temperatures that do not degrade the mechanical properties of the steel, and 3) outstanding corrosion-resistance to the alkaline environment of wet cement. The novel glass composite comprises at least 4.0% (wt) K<sub>2</sub>O and at least 5.6% (wt) ZrO<sub>2</sub>, with about 4-20% (wt) of K<sub>2</sub>O, and/or about 5-20% (wt) of ZrO<sub>2</sub>, whereas both K<sub>2</sub>O and ZrO<sub>2</sub> are significantly increased compared to the conventional groundcoats.

While the novel technology has been illustrated and described in detail in the drawings and foregoing description, the same is to be considered as illustrative and not restrictive in character. It is understood that the embodiments have been shown and described in the foregoing specification in satisfaction of the best mode and enablement requirements. It is understood that one of ordinary skill in the art could readily make a nigh-infinite number of insubstantial changes and modifications to the above-described embodiments and that it would be impractical to attempt to describe all such embodiment variations in the present specification. Accordingly, it is understood that all changes and modifications that come within the spirit of the novel technology are desired to be protected.

We claim:

1. A method for producing composite structural material comprising in combination:
  - providing a cementitious matrix;
  - positioning a plurality of steel reinforcing rods positioned in the cementitious matrix; and
  - substantially encapsulating each respective steel reinforcing rod in a vitreous shell; and
  - substantially encasing the plurality of steel reinforcing rods in the cementitious matrix;
 wherein each respective steel reinforcing rod has a coefficient of thermal expansion of between about 14 ppm/° C. and about 17 ppm/° C.; and
  - wherein each respective vitreous shell has a composition consisting essentially, in weight percent, of about 33-45% SiO<sub>2</sub>, 3.5-4.6% Al<sub>2</sub>O<sub>3</sub>, 13.5-19.5% B<sub>2</sub>O<sub>3</sub>, 4-13.5% K<sub>2</sub>O, and 5.5-15.5% ZrO<sub>2</sub>; and
  - wherein each respective vitreous shell has a coefficient of thermal expansion between about 12.5 ppm/° C. and about 13.5 ppm/° C.
2. The composite structural material method of claim 1 and further comprising a plurality of calcium silicate particles distributed throughout each respective vitreous shell.
3. The composite structural material method of claim 2 wherein the calcium silicate particles are bonded to the cementitious matrix.
4. The composite structural material method of claim 3 wherein the cementitious matrix is Portland cement.
5. The composite structural material method of claim 2 wherein the bond strength of the steel reinforcing rods in the cementitious matrix increases over time.
6. The composite structural material method of claim 1 and further comprising a plurality of zinc particles distributed throughout each respective vitreous shell.
7. A method of reinforcing concrete, comprising:
  - coating a plurality of steel reinforcing members with thin glass layers, wherein the respective steel reinforcing members have a first coefficient of thermal expansion and wherein the respective thin glass layers have a second coefficient of thermal expansion substantially matching the first coefficient of thermal expansion; and
  - forming a cementitious matrix around the plurality of steel reinforcing members;
  - wherein the glass layers have a composition consisting essentially, in weight percent, of about 33-45% SiO<sub>2</sub>, 3.5-4.6% Al<sub>2</sub>O<sub>3</sub>, 13.5-19.5% B<sub>2</sub>O<sub>3</sub>, 4-13.5% K<sub>2</sub>O, and 5.5-15.5% ZrO<sub>2</sub>.
8. The method of claim 7, wherein the steel reinforcing members have a composition selected from the group including ASTM A615, ASTM A706, ASTM A955 and ASTM A996.

9. The method of claim 7, wherein the glass layers have a coefficient of thermal expansion between about 12.5 and 13.5 ppm per degree Celsius.
10. The method of claim 7, wherein the glass layers contain about 10.5 to about 15.5 weight percent ZrO<sub>2</sub> and between about 13.0 and about 13.5 weight percent K<sub>2</sub>O.
11. The method of claim 7, wherein the thin glass layers further comprise a plurality of calcium silicate particles distributed therethrough and wherein the calcium silicate bonds with the cementitious matrix.
12. The method of claim 4, wherein the thin glass layers further comprise a plurality of metal particles distributed therethrough; and wherein the metal particles function as sacrificial anodes in a cementitious environment.
13. The method of claim 12 wherein the metal particles are zinc.
14. A method of making a reinforced cementitious composite material, comprising:
  - substantially encapsulating each of a plurality of respective steel reinforcing rods in a respective vitreous shell;
  - distributing bond-enhancing particles throughout each respective vitreous shell;
  - positioning the encapsulated steel reinforcing rods; and
  - substantially encasing the plurality of steel reinforcing rods in a cementitious matrix;
  - wherein each respective steel reinforcing rod has a coefficient of thermal expansion of between about 14 ppm/° C. and about 17 ppm/° C.; and
  - wherein each respective vitreous shell has a composition selected from the group consisting essentially, in weight percent, of about 33-45% SiO<sub>2</sub>, 3.5-4.6% Al<sub>2</sub>O<sub>3</sub>, 13.5-19.5% B<sub>2</sub>O<sub>3</sub>, 4-13.5% K<sub>2</sub>O, and 5.5-15.5% ZrO<sub>2</sub>; and
  - wherein each respective vitreous shell has a coefficient of thermal expansion between about 12.5 ppm/° C. and about 13.5 ppm/° C.
15. The method of claim 14 wherein the bond-enhancing particles are metallic; and wherein the metallic bond-enhancing particles act as sacrificial anodes.
16. The method of claim 15 wherein the metallic bond-enhancing particles are zinc.
17. The method of claim 14 wherein the bond-enhancing particles are calcium silicate; and wherein the calcium silicate bond-enhancing particles bond with the cementitious matrix.
18. The method of claim 14 wherein the bond-enhancing particles include both calcium silicate particles and metallic particles.

\* \* \* \* \*