



Missouri University of Science and Technology
Scholars' Mine

Electrical and Computer Engineering Faculty
Research & Creative Works

Electrical and Computer Engineering

01 Jul 2005

Comparison of Hybrid Propulsion Drive Schemes

Keith Corzine

Missouri University of Science and Technology

Shuai Lu

Follow this and additional works at: https://scholarsmine.mst.edu/ele_comeng_facwork

 Part of the [Electrical and Computer Engineering Commons](#)

Recommended Citation

K. Corzine and S. Lu, "Comparison of Hybrid Propulsion Drive Schemes," *Proceedings of the IEEE Electric Ship Technologies Symposium, 2005*, Institute of Electrical and Electronics Engineers (IEEE), Jul 2005. The definitive version is available at <https://doi.org/10.1109/ESTS.2005.1524700>

This Article - Conference proceedings is brought to you for free and open access by Scholars' Mine. It has been accepted for inclusion in Electrical and Computer Engineering Faculty Research & Creative Works by an authorized administrator of Scholars' Mine. This work is protected by U. S. Copyright Law. Unauthorized use including reproduction for redistribution requires the permission of the copyright holder. For more information, please contact scholarsmine@mst.edu.

Comparison of Hybrid Propulsion Drive Schemes

K.A. Corzine, *Member, IEEE* and S. Lu, *Student Member, IEEE*

Department of Electrical Engineering, University of Missouri - Rolla
1870 Miner Circle, Rolla, MO 65401-0040

Abstract – This paper provides a brief overview of a hybrid drives which have become popular in recent years. These drives combine two or more multilevel power inverters to obtain exceptional power quality which is necessary for Naval propulsion applications. Furthermore, for ship propulsion, where it may be difficult to obtain several isolated dc voltage sources, the inverter control can be set so that only one real dc power source is needed (or one per phase in the case of a series H-bridge type). Three types of hybrid drives considered and their advantages and limitations are described. Commonalities of the control of each hybrid drive type is discussed and three control schemes are applied to the various topologies in a set of simulation examples.

Index Terms – Multilevel, drives, power converters, cascaded inverters, H-bridge inverters.

I. INTRODUCTION

Motor drives based on the multilevel power conversion concept [1-3] have become increasingly popular in recent years due to advantages such as higher voltage capability, lower switching losses, better electromagnetic compatibility, and superior power quality when compared to traditional (two-level) methods. Other than the exponentially increasing number of IEEE publications in this area, the recent interest is evidenced by the fact that several Navy contractors including ABB, Alstom, Electric Boat, GE, Northrop Grumman, and Power Paragon have obtained patents in this area in the past six years.

An intriguing extension of the multi-level concept is the series or parallel combination of multiple inverters [4-21]. Within these combinational topologies is the hybrid drive defined as an inverter where the power is split between a higher-voltage low switching frequency "bulk" inverter and low-voltage high switching frequency "conditioning" inverter(s) [5, 10-13, 15, 18, 19, 21]. Since there is a multiplying effect between the number of voltage levels of the individual inverters, the hybrid drive can have exceptional power quality. Recent ONR-sponsored research demonstrated a hybrid inverter that has a voltage THD of 9% [18]. If a light filter is added to this inverter, the power quality can meet Navy specifications.

This paper provides an overview of three types of hybrid inverters that have been studied by independent researchers in recent years. The topologies and control schemes are explored through the use of several simulation examples.

II. HYBRID DRIVE TOPOLOGIES

A effective extension of multilevel motor drive technology [1-3] is to extend the power conversion by combing two or more multilevel inverters (or sometimes two-level inverters) in a series- or parallel-type connection in order to further improve the

power quality. This has been accomplished in several ways by different researchers in recent years. One method is to combine inverter outputs by use of ac-side transformers [4,5]. The inverter outputs can also be connected on the ac side using inter-phase reactors [6,7]. Another combinational topology involves the parallel connection of a current-source inverter with a voltage-source inverter [8,9].

To narrow the focus of this paper, only series-connected voltage-source inverters without ac-side transformers are studied. In particular, the three general topologies shown in Figure 1 are considered. Figure 1a shows the series multilevel H-bridge inverter. Therein, each phase consists of any number of H-bridge cells, each of which can have any odd number of voltage levels. A hybrid inverter can be formed from this topology by altering the dc voltage ratio of the series H-bridge inverters [10]. This method forms a hybrid drive since the higher-voltage cells supply the bulk of the power at a low switching frequency. An extension of this inverter is a method where the specific H-bridge cells are made from multilevel poles [11-13]. It can also be shown that the isolated dc power supplies can be replaced with capacitors and only one real power dc source is required for each phase [12,13].

Figure 1b illustrates the generalized cascaded multilevel inverter. This topology involves splitting the neutral of the motor load and connecting each end of both phase windings to a multilevel inverter. This structure was first introduced in 1993 [14] with the isolated dc voltages having equal value. By changing the ratio of the dc voltages, the number of voltage levels can be greatly extended [15-17]. As with the series H-bridge topology of Figure 1a, it is possible to replace one of the dc sources with a capacitor and regulate its voltage by using the inverter control [18,19].

Figure 1c shows a third hybrid combination. It is similar to the series H-bridge inverter with a common three-phase inverter. As with the series H-bridge inverter, any number of H-bridge cells can be included. The voltage ratios between the main dc link and each H-bridge cell can be set to obtain higher power quality [20,21]. Since this is a combination of the diode-clamped and series H-bridge topologies, it is referred to as the DCH multilevel inverter herein.

To further narrow the focus of this paper, each of the three topologies will be reduced in number of potential voltage levels so that only one real dc source is required (or one per phase in the case of the series multilevel H-bridge). The remaining sources will be replaced with capacitors and the inverter control will have the task of regulating the capacitors to specific constant values. Herein, the values of the capacitor voltages will be chosen to maximize the number of ac voltage levels obtainable.

A. Assessment of Hybrid Drive Topologies

In most applications, the series H-bridge inverter of Figure 1a has the advantage that the voltage and power levels can be easily

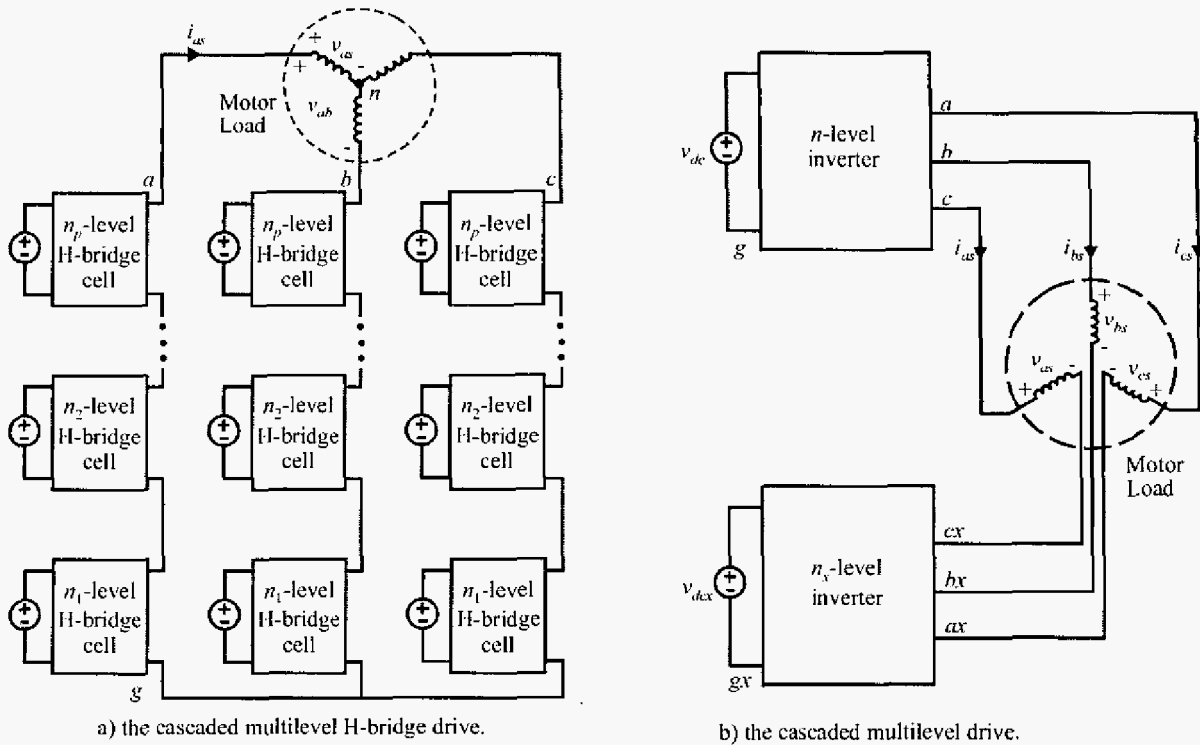

Figure 1. Various types of hybrid multilevel inverter drives.

expanded by increasing the number of H-bridge cells. This advantage decreases in the hybrid case (where the dc voltage ratios are altered to obtain better power quality) since the cells are asymmetrical and not modular. The advantage of expandability disappears in the case where only one real power source per phase is used. However, the power quality can still be greatly increased by adding more cells due to the multiplying effect of the voltage levels. One primary disadvantage of the series H-bridge multilevel inverter is the need for three isolated real power sources. On a ship system, creation of these sources adds to the weight and volume of the drive. Furthermore, the sources are supplying single-phase power and can require a relatively large capacitance.

The cascaded multilevel inverter shown in Figure 1b is relatively simple to construct from standard three-phase inverters. One disadvantage of this structure is the need to have access to both ends of each phase winding. In industrial applications, this could be troublesome. In Naval propulsion applications, the motor is typically custom made and accessing all six terminations is not an issue. As the examples below will illustrate, this topology can operate from one real power three-phase voltage source.

The DCH structure combines advantages of the series H-bridge and cascaded multilevel inverters. Through suitable control, it is possible to supply all of the H-bridge cells with a capacitor source so that only one real power source is needed.

This topology also has the advantage of not requiring access to both ends of each phase winding.

B. Hybrid Drive Control Schemes

The control of a hybrid motor drive involves multilevel modulation as well as capacitor voltage regulation. Multilevel modulation is a fairly straightforward extension of traditional two-level modulation schemes [15]. Capacitor voltage regulation can be accomplished in a number of ways. One method is the use of redundant state selection (RSS) between the available voltage vectors. Selecting between redundant states results in little disturbance of the ac voltages, but a large change in the capacitor voltage balancing situation. If redundant states are available within a particular phase (per-phase RSS), this option can lead to a fairly straightforward control. This can be accomplished by changing the dc voltage ratio and reducing the number of voltage levels [12] as will be demonstrated in one of the series multilevel H-bridge examples below. If per-phase RSS is not available, redundant states involving all phases (joint-phase RSS) can be used [18]. This method is somewhat more time intensive than per-phase RSS since information about the capacitor voltages (in the H-bridge cases) and currents from all phases must be considered. In a practical implementation, the joint-phase RSS method can be programmed in a table off-line and used instantaneously during drive operation.

One disadvantage of capacitor voltage regulation through RSS is that the higher-voltage bulk inverter may be required to switch with narrow pulses. This can be avoided by forcing the bulk inverter to operate in a step mode at the fundamental frequency and then controlling the conditioning inverter in PWM mode to completely compensate the harmonics from the bulk inverter and regulate its capacitor voltages at the same time. For higher power systems, this control is more reasonable than using RSS for capacitor voltage balance. Examples of the cascaded multilevel inverter below will illustrate this control and compare it to the RSS method.

Another option for controlling the hybrid drive is the addition of common-mode harmonic terms to the drives output voltage reference signal. These harmonic terms can be set to ensure that the conditioning inverters supply positive average power [20] or only reactive power so that capacitor sources may be used [21].

III. HYBRID DRIVE EXAMPLES

The examples in this section will be used to clarify some of the similarities in the control of the various drive topologies. The series H-bridge drive will be used to illustrate the differences between per-phase and joint-phase RSS control. The cascaded multilevel inverter will be used to illustrate the differences between RSS control and step control in the bulk inverter. Two advances of the DCH hybrid drive are shown. First the concept of using multi-level poles in the H-bridge inverters will be demonstrated. Next, the use of two H-bridge cells per phase will be demonstrated. Simulation with the RSS method will show that complete capacitor voltage regulation can be achieved in both cases.

A. Series Multilevel H-Bridge Drive

As a specific example of the generalized series multilevel H-bridge drive of Figure 1, consider the structure shown in Figure

2. In this example, a five-level H-bridge is used for the bulk inverter and a typical three-level H-bridge is used for the conditioning inverter. This combination is referred to as the cascade-5/3H inverter. As can be seen, one real source per phase is required to supply the bulk inverters. Capacitor voltage balancing within the bulk inverter (to ensure $v_{c1} = v_{c2}$) can be readily accomplished by using redundant switching states within the five-level bulk inverter [11]. In order to obtain the maximum number of voltage levels on the ac output, the dc voltage ratio must be set to $v_{dc1a} = 6v_{dc2a}$. This will result in a maximum of fifteen levels (the product of the bulk and conditioning inverter number of levels). Figure 3 shows the plot of available voltage vectors in the $q-d$ reference plane [18] with $v_{dc1a} = 6v_{dc2a}$. Therein, the bold vectors are the vectors created by the bulk inverter and the other vectors are formed by a combination of bulk and conditioning inverter switching. The dashed hexagon

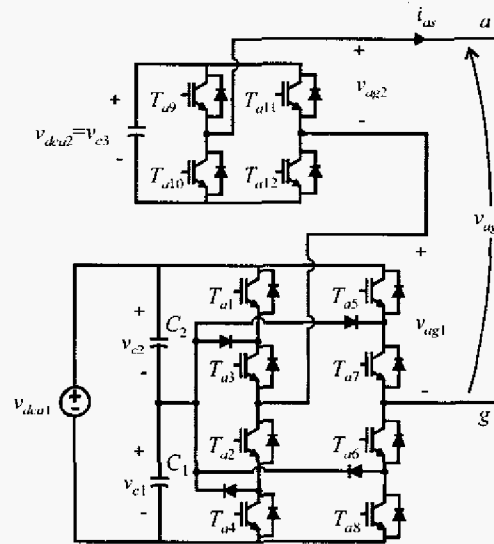

Figure 2. The cascade-5/3H inverter topology (a -phase).

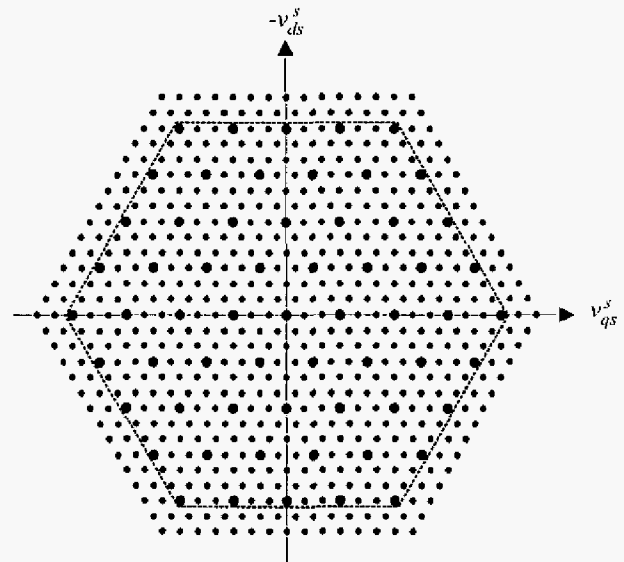

Figure 3. Voltage vector plot of the cascade-5/3H inverter with $v_{dc1a} = 6v_{dc2a}$.

indicates the voltage limit imposed if the conditioning inverter is supplied from a capacitor. As can be seen, within this limit, the inverter can operate as a thirteen-level inverter. The specific performance depends on the control scheme used. For the joint-phase RSS method, the performance will have thirteen levels. For per-phase RSS, the performance will be lowered to eleven-level so that the control can be contained within each phase. Examples below will clarify the per-phase and joint-phase RSS controls. Although not covered in this section, it is possible to operate this inverter in fourteen-level mode by forcing the bulk inverter to switch at the fundamental frequency. This type of control will be applied to the cascaded multilevel inverter in the next section.

The per-phase RSS control scheme operates as follows. First the voltage ratio is changed to $v_{dc1} = 4v_{dc2} = 4E$ in order to reclaim per-phase redundancy. In this case, the voltage E is used for simplicity and represents the voltage of the conditioning inverter. Table I shows the full range of switching states for the a -phase using this new voltage ratio. As can be seen the inverter operation is reduced to eleven-level. The per-phase capacitor voltage balancing method works by eliminating the highest and lowest voltage levels (reducing the performance to nine-level). Of the remaining levels, the ones in which the conditioning inverter output is $v_{ag2} = 0$ will not affect capacitor voltage balance. As can be seen, other remaining levels involve a simple choice between a positive or negative conditioning inverter output which amounts to placing the capacitor in series in one direction or the opposite direction. This choice can be made on-line depending on the direction of the phase current and whether the capacitor needs to be charged or discharged to maintain the voltage ratio. The control process is then to use a standard eleven-level modulation [18] for each phase and follow the modulator output with a simple per-phase RSS decision. Figure 4 shows a simulation result for this mode of operation. For this simulation, the inverter is supplying a 1-MW 4160-V R-L load with a power factor of 0.8 lagging. The modulation index of the modulator is set to its maximum and the dc voltage is adjusted so that the output voltage is rated. The line-to-line voltage, line-to-neutral voltage, and phase current (as labeled in Figure 1) are shown followed by the bulk inverter output voltage, conditioning inverter output voltage, and conditioning capacitor voltage (as labeled in Figure 2). The inverter exhibits typical nine-level performance with a voltage THD of 7.76%. One disadvantage of this scheme is that the RSS switching causes the bulk inverter to operate at a higher switching frequency. As can be seen, the capacitor well regulated through the RSS control.

To improve the performance of this drive, the joint-phase RSS control scheme is used with the voltage ratio set to $v_{dc1a} = 6v_{dc2a}$. In the joint-phase RSS mode, the modulator is followed by redundant decisions involving all three-phases. The switching state of all phases can be increased or decreased by the same amount which changes the common-mode inverter voltage without affecting the load voltages. The joint-phase RSS decision is then to cycle through all of the possible joint redundant states and evaluate each one based on the overall capacitor voltage balance. The evaluation assigns a priority depending on in how many phases the redundant state can improve the capacitor voltage balance of the conditioning inverter. Figure 5 shows the simulation output result using the

same load conditions as in the first study. The dc voltage is lowered in this case to match the load. Comparing this scheme to the previous simulation, it can be seen that the power quality has been increased. This can be seen in the line-to-line voltage which displays thirteen-level operation and in the line-to-neutral

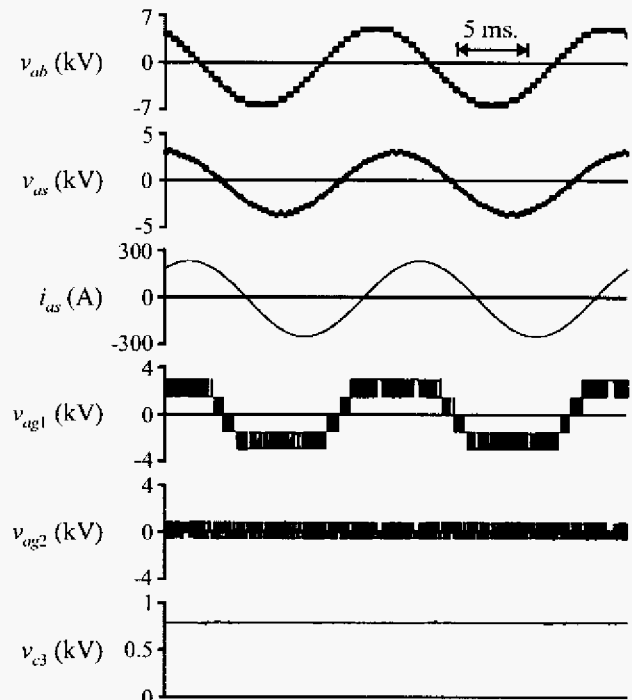

Figure 4. Cascade-5/3H inverter operating with per-phase RSS in 9-level mode.

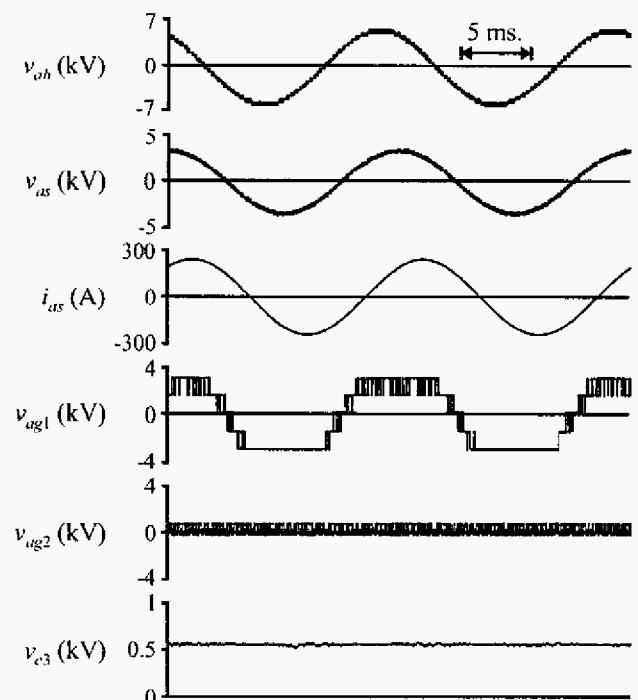

Figure 5. Cascade-5/3H inverter operating with joint-phase RSS in 13-level mode.

voltage which has a THD is 5.11%. Also, the bulk inverter switches less often and thus has lower switching losses.

However, the bulk inverter still contains narrow pulses. This issue will be resolved by an alternate control scheme introduced in the next section.

v_{ag}	v_{ag1}	v_{ag2}
$-5E$	$-4E$	$-E$
$-4E$	$-4E$	0
$-3E$	$-4E$	E
$-2E$	$-2E$	$-E$
$-E$	$-2E$	0
0	0	E
E	0	$-E$
$2E$	$2E$	0
$3E$	$2E$	E
$4E$	$4E$	$-E$
$5E$	$4E$	0

B. Cascaded Multilevel Drive

Figure 6 shows the topology for the cascade-3/3 inverter which will be used to illustrate the next control scheme. It is a cascaded connection (through the neutral of the load) of two three-level diode clamped inverters. If the voltage ratio is set to $v_{dc} = 3v_{dcx}$, a maximum of nine voltage levels is obtained (the product of the number of levels of each inverter). The vector plot for this voltage ratio is shown in Figure 7. Considering the limit of the bulk vectors outlined by the dashed hexagon, it can be seen that seven-level performance is obtainable when only one real power source is used.

The first stimulation utilizes joint-phase RSS as described above. In this case, a typical nine-level modulation scheme is used [18] followed by joint redundancy which has the goal of regulating the four capacitors to their ideal values. Figure 8 shows the simulation results. In this case, the line-to-line voltage is defined as $v_{ab} = v_{as} - v_{bs}$. Based on this voltage, seven-level performance can be verified. In this simulation, the line-to-neutral voltage THD is 9.97%. As with the series H-bridge examples, this scheme leads to narrow pulses in the bulk inverter voltage. This shortcoming is overcome with the next example.

Another option for controlling hybrid drives is to force the bulk to switch at the fundamental frequency and compensate the voltage harmonics using the conditioning inverter. For the cascade-3/3 inverter operating with a high modulation index, this amounts to having the bulk inverter step from one bold vector to the next along the dashed hexagon in Figure 7. Since the fundamental component of the bulk voltages forms a circle in the $q-d$ stationary plane, this circle will be larger than the dashed hexagon at certain places in the cycle. At these times, the conditioning inverter will compensate by using vectors slightly outside of the hexagon. Therefore, this control method will result in eight-level operation. The control of the conditioning inverter first monitors the instantaneous real and reactive power supplied by the bulk inverter. Next, the power is compensated so that the average power going to the load is constant (a

requirement for sinusoidal conditions). Based on this commanded power and the measured currents, the conditioning inverter commanded voltages can be determined. The details of

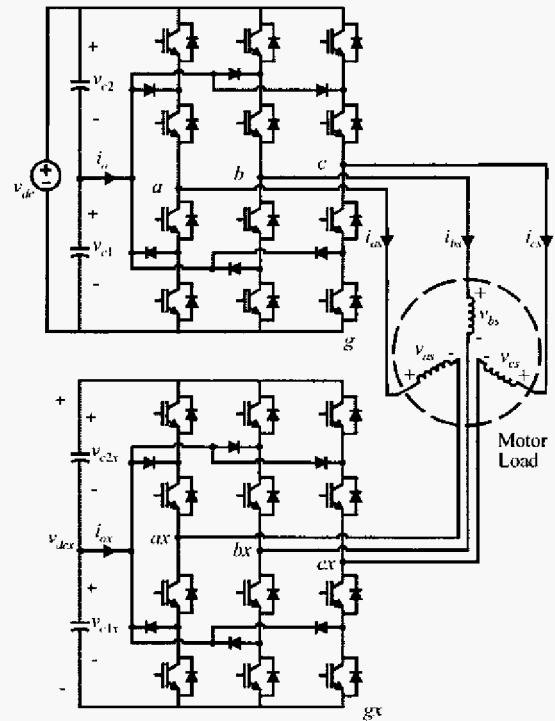

Figure 6. The cascade-3/3 multi-level inverter.

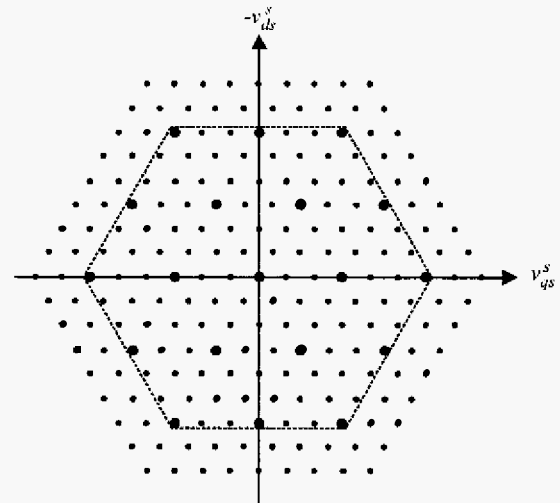

Figure 7. Cascade-3/3 vector plot with $v_d = 3v_{dx}$.

this method can be found in the literature [19] and are similar to P-Q theory control of active filters. An advantage of controlling the conditioning inverter in this way is that its capacitor voltage can be easily regulated by adding to or subtracting from the commanded power of the conditioning inverter. Figure 9 shows the simulation results for this case where the load conditions are the same as previous simulations. It can be seen that the bulk inverter is switching at the fundamental frequency and the conditioning inverter capacitor is well regulated. The line-to-line voltage indicates eight-level operation and the line-to-neutral voltage THD is 9.36%.

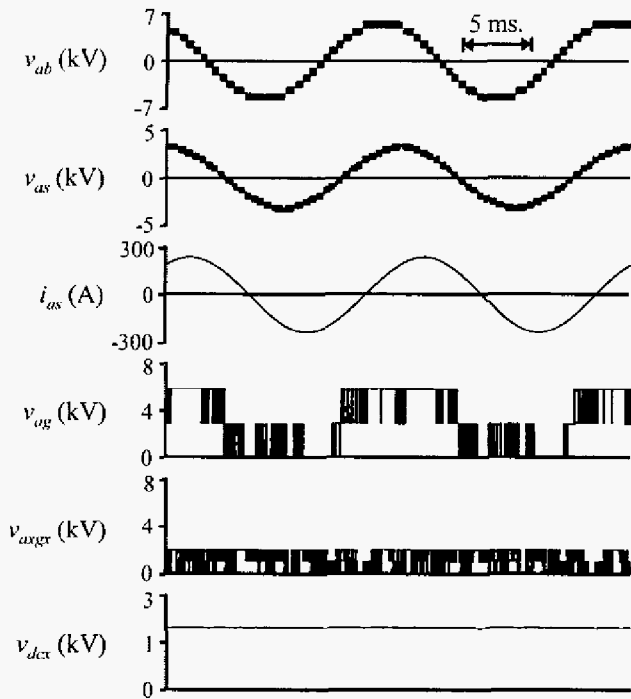

Figure 8. Cascade-3/3 inverter simulation results operating in 7-level mode.

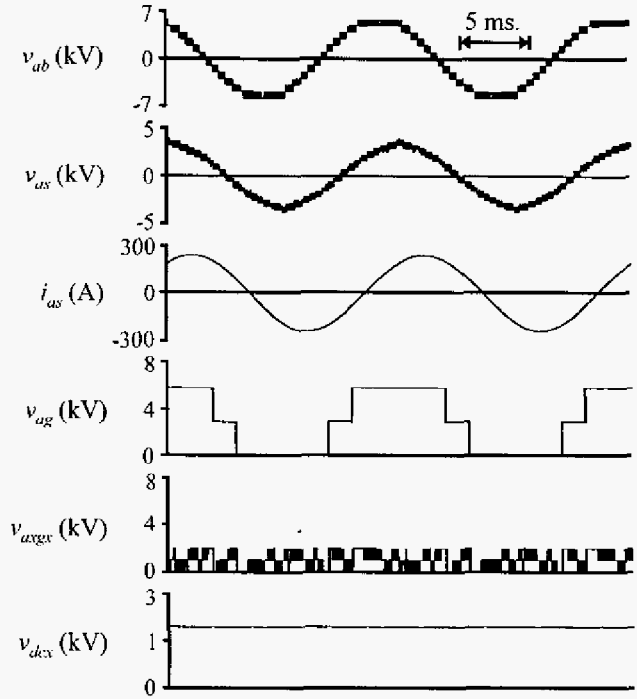

Figure 9. Cascade-3/3 inverter simulation results operating in 8-level mode.

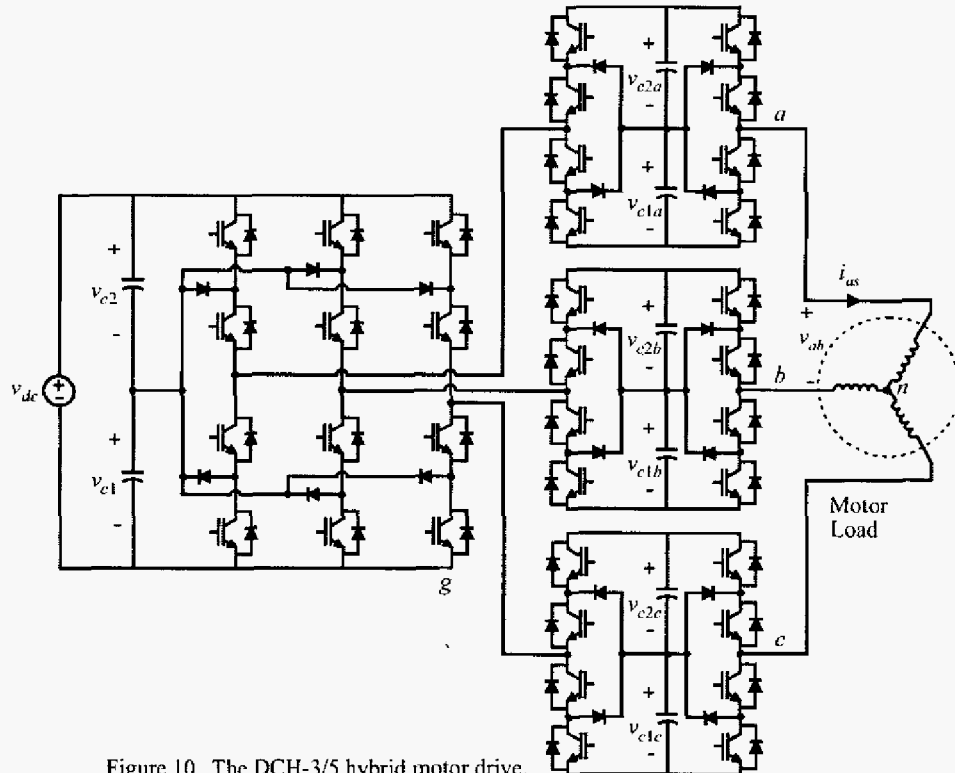

Figure 10. The DCH-3/5 hybrid motor drive.

C. Diode-Clamped/H-Bridge (DCH) Drive

In this section, two new types of DCH hybrid drives will be introduced. The joint-phase RSS control will be used in both cases. The first example is the DCH-3/5 inverter formed from a traditional three-level inverter supplying a five-phase H-bridge

cell in each phase as shown in Figure 10. In this case, the dc voltage v_{dc} must be five times the total H-bridge dc voltage to obtain fifteen-level capability. For example, in the a -phase dc voltages would be set according to $v_{dc} = 5(v_{dc1a} + v_{dc2a})$. The capacitors within each H-bridge should be of equal voltage, but

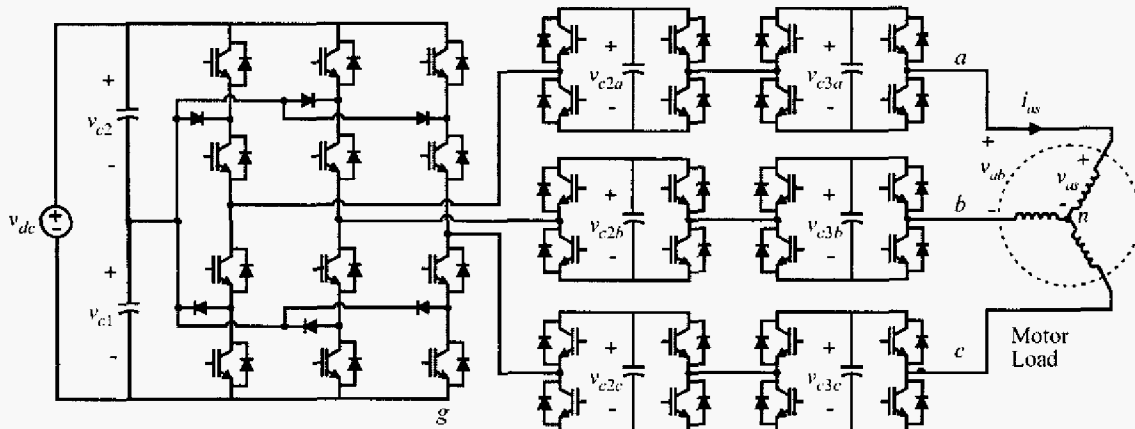

Figure 12. The DCH-3/3/3 hybrid motor drive.

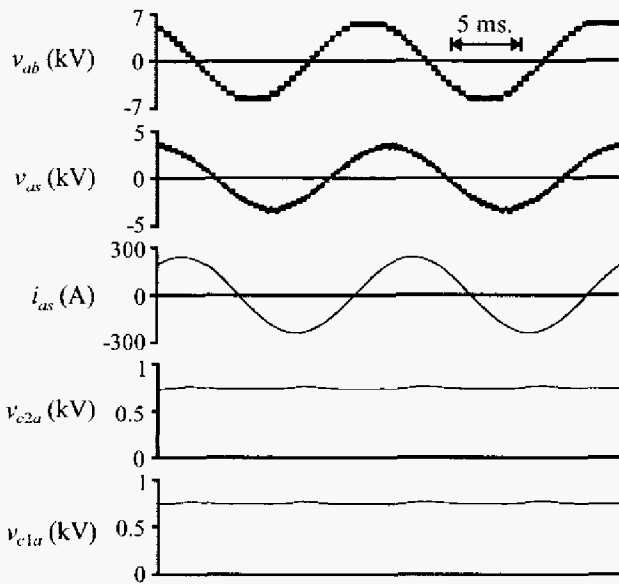

Figure 11. DCH-3/5 inverter simulation results.

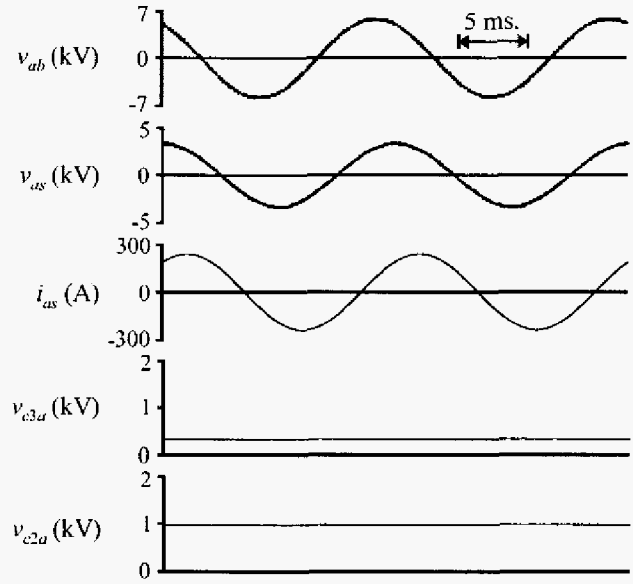

Figure 13. DCH-3/3/3 inverter simulation results.

this can be ensured by redundancy within the conditioning inverter [11]. The vector plot is not included due to space limitation, but it has the appearance of a traditional three-level inverter vector plot with a five-level plot around each bulk vector. Considering the limitation of the bulk voltage in the vector diagram, it could be concluded that this inverter will operate as an eleven-level inverter if the conditioning inverters are supplied from capacitor sources. Figure 11 shows the simulation results. Besides the load voltages and currents the α -phase capacitor voltages are shown. As can be seen, they are well regulated using the joint-phase RSS control. The line-to-neutral voltage THD in this example is 7.25%.

The next example is the DCH-3/3/3 inverter shown in Figure 12. The ratio which yields the maximum number of voltage levels in this case is $v_{dc} = 6v_{c2a} = 18v_{c3a}$. This will result in twenty-seven-level performance. In order for all six capacitors to be regulated to these voltages, the joint-phase RSS control will reduce the performance to nineteen-level operation. In this case, the joint-phase RSS assigns priorities based on all six floating capacitors. The simulation results are shown in Figure 13 using the same loading conditions as with the previous

simulations. The load voltage exhibits exceptional power quality in this case due to the multiplication of the voltage levels with the addition of a third inverter stage. The line-to-neutral voltage THD in this example is 3.37%. The overall line-to-ground voltage is also shown to indicate that the common-mode inverter voltage is being changed considerably for capacitor voltage regulation.

VI. CONCLUSION

This paper presented an overview of three types of hybrid inverter topologies and three types of hybrid inverter control schemes. The series multilevel H-bridge inverter offers the advantage of expandability, but requires at least one real power single-phase voltage source per phase. The cascaded multilevel inverter is straightforward to construct, but requires access to both ends of each phase coil. The diode-clamped / H-bridge hybrid combines the advantages of the series H-bridge and cascaded multilevel drives. For these three drive types, there is a commonality in the control methods. This paper explored per-phase and joint-phase redundancy schemes for capacitor voltage regulation. Also, a method of greatly reducing the frequency in

the bulk inverter was shown. Examples of the various control schemes demonstrated exceptional power quality. This is particularly the case of the DCH hybrid inverter, an example of which operates with 3.37% voltage THD.

REFERENCES

- [1] R.H. Baker, *Electric Power Converter*, U.S. Patent Number 3,867,643, February 1975.
- [2] R.H. Baker, *High-Voltage Converter Circuit*, U.S. Patent Number 4,203,151, May 1980.
- [3] T.A. Meynard and H. Foch, "Multi-level Conversion: High Voltage Choppers and Voltage-Source Inverters," *Proceedings of the IEEE Power Electronics Specialist Conference*, pages 397-403, 1992.
- [4] S. Masukawa and S. Tida, "A Method for Reducing Harmonics in Output Voltages of a Double-Connected Inverter," *IEEE Transactions on Power Electronics*, volume 9, number 5, pages 543-550, September 1994.
- [5] H. Rudnick, J. Dixon, and L. Moran, "Delivering Clean and Pure Power," *IEEE Power and Energy Magazine*, pages 32-40, September/October 2003.
- [6] S. Ogasawara, J. Takagaki, H. Akagi, and A. Nabe, "A Novel Control Scheme of a Parallel Current-Controlled PWM Inverter," *IEEE Transactions on Industry Applications*, volume 28, number 5, pages 1023-1030, September / October 1992.
- [7] E. Cengeli, P. Enjeti, C. Singh, F. Blaabjerg, and J.K. Pederson, "New Medium Voltage PWM Inverter Topologies for Adjustable Speed AC Motor Drive Systems," *Proceedings of the IEEE Applied Power Electronics Conference*, volume 2, pages 565-571, February 1998.
- [8] S. Kwak and H.A. Toliyat, "A Hybrid Solution for Load-Commutated-Inverter-Fed Induction Motor Drives," *IEEE Transactions on Industry Applications*, volume 41, number 1, pages 83-90, January/February 2005.
- [9] S. Kwak and H. Toliyat, "A Current Source Inverter with Advanced External Circuit and Control Method," *Proceedings of the IEEE International Electric Machines and Drives Conference*, May 2005.
- [10] M.D. Manjrekar and T.A. Lipo, "A Hybrid Multilevel Inverter Topology for Drive Applications," *Proceedings of the IEEE Applied Power Electronics Conference*, volume 2, pages 523-529, Anaheim CA, February 1998.
- [11] K.A. Corzine, *Cascaded Multi-Level H-Bridge Drive*, U.S. Patent Number 6,697,271, Assigned to Northrop Grumman Corporation, February 2004.
- [12] K.A. Corzine, F.A. Hardrick, and Y.L. Familiant, "A Cascaded Multi-Level H-Bridge Inverter Utilizing Capacitor Voltage Sources," *Proceedings of the IASTAD Power Electronics Technology and Applications Conference*, Palm Springs California, February 2003.
- [13] K. Iwaya and I. Takahashi, "Novel Multilevel PWM Wave Control Method Using Series Connected Full Bridge Inverters," *Proceedings of the IEEE International Electric Machines and Drives Conference*, volume 3, pages 1543-1548, June 2003.
- [14] H. Stemmler and P. Guggenbach, "Configurations of High-Power Voltage Source Inverter Drives," *Proceedings of the European Conference on Power Electronics and Applications*, volume 5, pages 7-14, September 1993.
- [15] K.A. Corzine and S.D. Sudhoff, "High State Count Power Converters: an Alternate Direction in Power Electronics Technology," *SAE Transactions, Journal of Aerospace*, Section 1, pages 124-135, 1998.
- [16] K.K. Mohapatra, K. Gopakumar, V.T. Somasekhar, and L. Umanand, "A Harmonic Elimination and Suppression Scheme for an Open-End Winding Induction Motor Drive," *IEEE Transactions on Industrial Electronics*, volume 50, number 6, pages 1187-1198, December 2003.
- [17] M.R. Baiju, K. Gopakumar, K.K. Mohapatra, V.T. Somasekhar, and L. Umanand, "Five-Level Inverter Voltage-Space Phasor Generation for an Open-End Winding Induction Motor Drive," *IEEE Proceedings - Electric Power Applications*, volume 150, number 5, pages 531-538, Sept. 2003.
- [18] K.A. Corzine, M.W. Wielebski, F.Z. Peng, and J. Wang, "Control of Cascaded Multi-Level Inverters," *IEEE Transactions on Power Electronics*, volume 19, number 3, pages 732-738, May 2004.
- [19] S. Lu, K.A. Corzine, and T.H. Fikse, "Advanced Control of Cascaded Multilevel Drives Based on P-Q Theory," *Proceedings of the IEEE International Electric Machines and Drives Conference*, May 2005.
- [20] P. Steimer, *Operating a Power Electronic Circuit Arrangement Having Multiple Power Converters*, U.S. Patent Number 6,009,002, Assigned to ABB, December 1999.
- [21] M. Veenstra and A. Rufer, "Control of a Hybrid Asymmetric Multilevel Inverter for Competitive Medium-Voltage Industrial Drives," *IEEE Transactions on Industry Applications*, volume 41, number 2, pages 655-664, March/April 2005.