



Missouri University of Science and Technology
Scholars' Mine

Electrical and Computer Engineering Faculty
Research & Creative Works

Electrical and Computer Engineering

01 Apr 2008

Design and FPGA Prototyping of a Flood Prediction System

Sandeep Gandla

Waleed K. Al-Assadi

Missouri University of Science and Technology, waleed@mst.edu

Sahra Sedigh

Missouri University of Science and Technology, sedighs@mst.edu

Raghu A. R. Rao

Follow this and additional works at: https://scholarsmine.mst.edu/ele_comeng_facwork

 Part of the [Electrical and Computer Engineering Commons](#)

Recommended Citation

S. Gandla et al., "Design and FPGA Prototyping of a Flood Prediction System," *Proceedings of the IEEE Region 5 Conference (2008, Kansas City, MO)*, Institute of Electrical and Electronics Engineers (IEEE), Apr 2008.

The definitive version is available at <https://doi.org/10.1109/TPSD.2008.4562765>

This Article - Conference proceedings is brought to you for free and open access by Scholars' Mine. It has been accepted for inclusion in Electrical and Computer Engineering Faculty Research & Creative Works by an authorized administrator of Scholars' Mine. This work is protected by U. S. Copyright Law. Unauthorized use including reproduction for redistribution requires the permission of the copyright holder. For more information, please contact scholarsmine@mst.edu.

Design and FPGA Prototyping of a Flood Prediction System

Sandeep Gandla, Waleed K. Al-Assadi, Sahra Sedigh and Raghu A. R. Rao
Department of Electrical and Computer Engineering,
Missouri University of Science and Technology
Rolla, MO 65409-0040

Abstract-This paper explains the chip design of a flood prediction system based on piezoelectric pressure sensors, and its FPGA prototyping. The sensors are placed at different water levels and can dependably predict the occurrence of a flood. The main criteria considered in design of the system are low cost, low power consumption, ease of installation, autonomy, reliability, and most importantly, provision of early alerts. Predicting the flood before its actual occurrence can buy sufficient time for residents to evacuate nearby areas, preventing loss of life and property. The design has been prototyped on Altera's Cyclone DE2 FPGA board.

Keywords: Wireless Sensor, FPGA, VHDL, Piezoelectric Pressure Sensors, Flood Protection

I. INTRODUCTION

Flooding happens when there are heavy rains, when rivers overflow, when ocean waves come onshore, when snow melts too fast or when dams or levees break. Flooding is the most common of all natural hazards in US and causes significant and irretrievable damage to life and property [1]. The magnitude of the losses caused by the recent hurricanes Katrina and Rita underscore the limitations of current flood-detection and prediction systems.

Current systems are primarily based on satellite and microwave imaging techniques [2]-[3]-[10], which are expensive, can be inconsistent and hazardous, and need complex algorithms to incorporate the effects of noise and wind. Other systems use ultrasonic, electromagnetic, chemical, and radiation sensors for flood prediction, which are prone to interference from phenomena such as temperature fluctuations, humidity, and electromagnetic noise. This necessitates additional hardware to adapt the system such that it maintains correct operation under changing environmental conditions. Furthermore, ultrasonic sensors can only be placed only under bridges, complicating their installation. These limitations led to the choice of piezoelectric pressure sensors [6] for the system described in this paper.

Another limitation of existing flood detection systems is their lack of self-checking circuits, which limits their reliability. Reliability is a critical factor in prediction and detection of catastrophic events such as floods, and has been the foremost concern in design of the system presented in this paper. Other considerations in design of the chip and system include low cost, low power consumption, ease of installation,

autonomy, and reliability.

The flood prediction system consists of two sensor nodes, one base node, and a base station, as shown in Fig. 1. The assembly of two sensor nodes and the base node, placed 80m apart, is deployed 60-70 miles away from the limits of the city of interest. A total of three nodes are used to ensure that correct data can be determined by voting even if one node collects erroneous information. All of the nodes are equipped with a chip that uses piezoelectric pressure sensors for measuring relevant flood parameters at that location. The two sensor nodes collect data and transmit it to the base node. The base node is also equipped with a chip that measures flood parameters, but it also processes the data received from the sensor nodes.

This data, which includes final flood parameters such as water level, flow rate, self-check data, i.e., battery status, sensor position and sensor status, and any alerts generated, is transmitted by the base node to the base station located in an appropriate emergency management office in the city. The base station decodes the data received from the base node and outputs the current flood conditions.

The focus of this paper is on the chip design of the sensor and base nodes. Long-range communication and design of the base station will be the subjects of future work on the system. Zigbee [7] was chosen as the short-range communication protocol, due to its support of low data rates, and its low power consumption, which prolongs the battery life. A battery status circuit and sensor position check circuit, respectively are used to provide assurance that the battery and sensors are operational. These circuits transmit the status to the base station and guide suitable repair actions, e.g., replacement of battery.

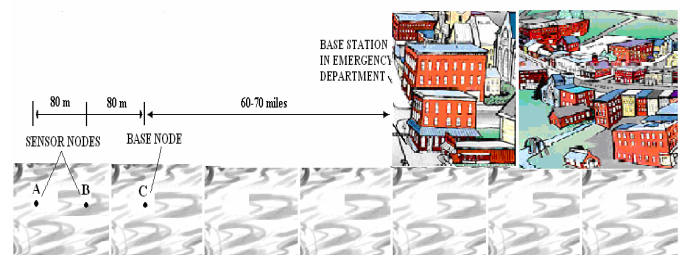

LOCATION OF SENSOR NODES, BASE NODE AND BASE STATION

Fig. 1: The flood prediction system.

II. PROPOSED SYSTEM DESIGN

The flood prediction system consists of two sensor nodes, a base node and a base station located in the offices of an emergency management authority. In Fig. 1, the two sensor nodes are at locations A and B, and the base node is at location C. The general block diagram of the base node is shown in Fig. 2. Further detail of the internal structure of this node is illustrated in Fig. 3. The base node includes a false trigger correction block used to check the correctness of the sensor operations. This block sends both test data and normal data to the base station, where the data is compared and validated.

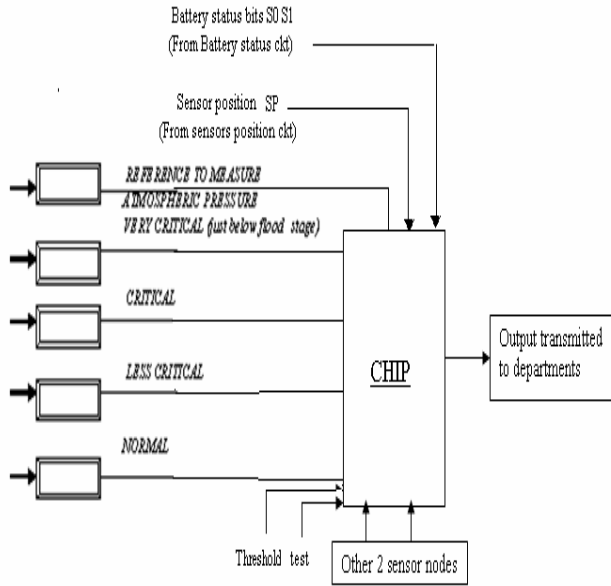

Fig. 2. Block diagram of the base node.

With the exception of the false trigger correction block, the internal structure of the sensor nodes is identical to that of the base nodes. Each node is equipped with a battery for operation of the circuitry, piezoelectric pressure sensors for sensing the water level, and ZigBee transmitters and receivers. Each node determines the water level at its location and reports it as normal, less critical, critical, or very critical, the latter of which occurs immediately prior to flooding. The threshold for each level is the same at all three nodes. A piezoelectric pressure sensor is placed at pre-specified locations that correspond to each threshold. An additional piezoelectric pressure sensor is used for reference measurement of the barometric pressure.

A piezoelectric pressure sensor test measures the pressure (flow rate -physical quantity) exerted by water or air, and converts it into a corresponding voltage (electrical quantity). These voltages are given as the inputs to the analog multiplexer of the chip, which in turn selects data from one of the four pressure sensors, as dictated by the control circuitry. The select signal for this operation is depicted in Fig. 4.

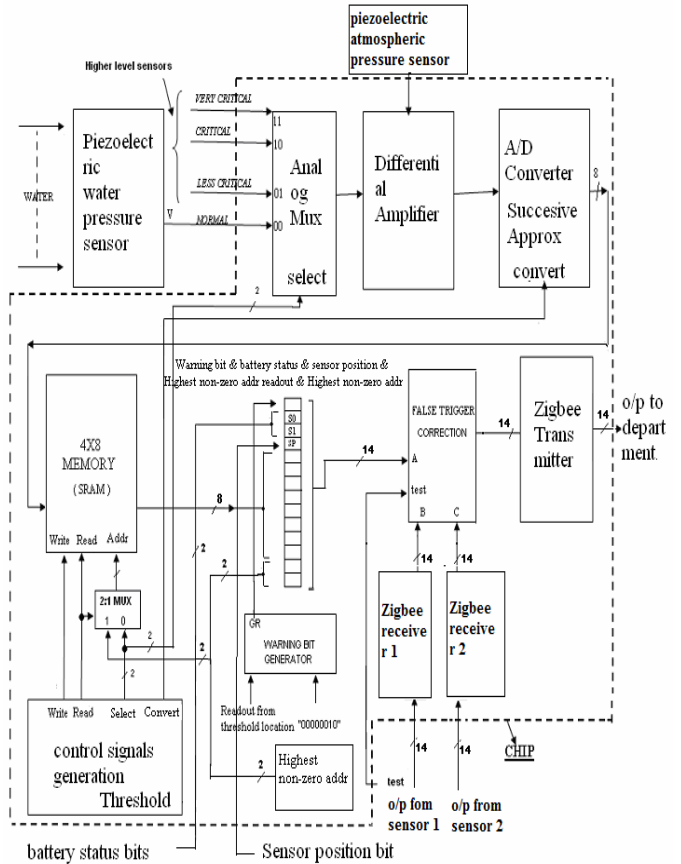

Fig. 3. Internal structure of the base node.

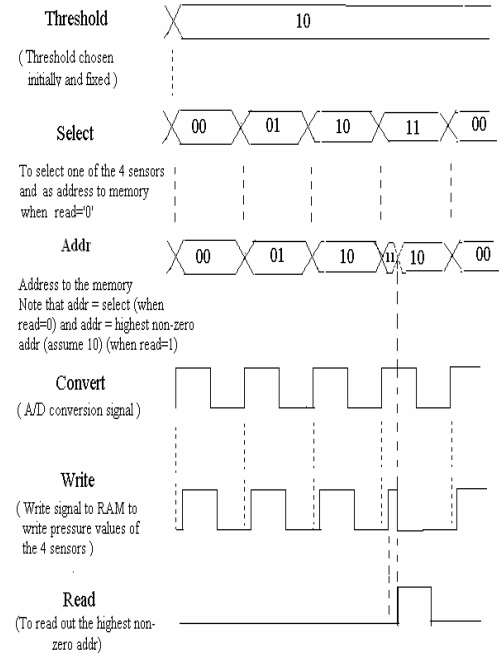

Fig. 4. Timing diagram for control signals.

The output of the analog multiplexer is given as one of the primary inputs to a differential amplifier. Another input is

from a piezoelectric sensor that measures the barometric pressure as the reference value. The output of the differential amplifier is a measure of the additional pressure exerted by the water, as compared to the air pressure. This analog output of the differential amplifier is fed to an A/D converter, which operates based on the address and write signal depicted in Fig. 4.

The write signal is delayed to allow for the conversion time of the A/D converter. The data corresponding to all water pressure sensors at a node is written to memory. If this data is zero at a given address, it indicates that the output of the differential amplifier is zero, i.e., no pressure has been exerted by the water on sensor, meaning that the water has not risen to the level where the sensor is placed. A logic block consisting of a register, an increment pointer, and a comparator finds the highest non-zero address that corresponds to the current water level.

The pressure value stored in the highest non-zero address in the memory is then read out on the positive edge of the read signal shown in Fig. 4. To account for the possibility of noise affecting the two pressure levels being compared, a leeway is allowed (0000010). Through a warning bit generator, which is basically a comparator with inputs of “0000010” and the threshold address readout, and an output of “greater than,” a warning bit is generated. The threshold can correspond to either the less critical or the critical water level, depending on probability of flood occurrence in the region. The warning bit is set to 1 if the threshold is exceeded.

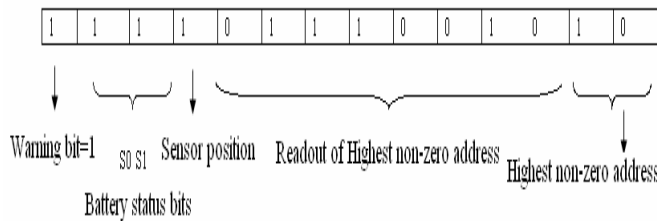

Fig. 5a. Data transmission with Warning bit = 1

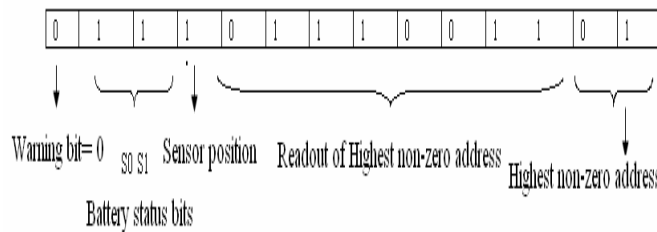

Fig. 5b. Data transmission with Warning bit = 0

Additional parameters, namely the battery status and sensor position bits, and the highest non-zero address readout and address are also transmitted and decoded at the base station to determine the current flood conditions. The data transmitted for warning and non-warning conditions, respectively, is depicted in Figs 5a and 5b.

False Trigger Correction Block

The false trigger correction circuit depicted in Fig. 6 has been included in the system to avoid the transmission of warnings based on incorrect data from the sensor nodes, which can be caused by debris or animals in the water. The assumption is that since the sensor nodes at A are closely spaced in the same river, a considerable difference in their measurements can indicate an error.

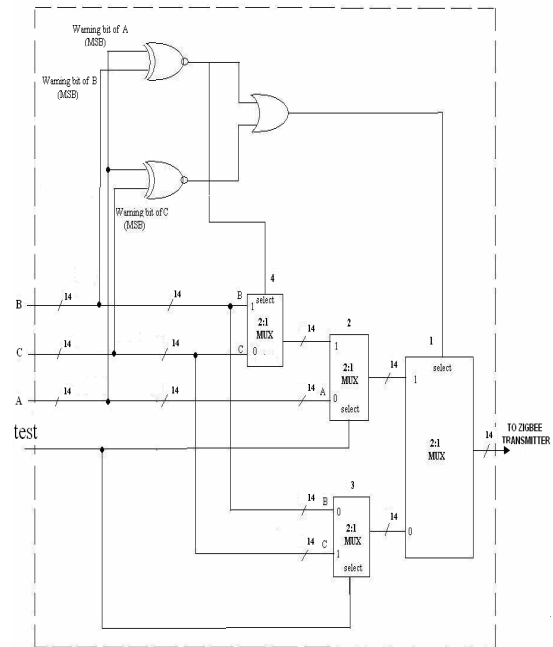

Fig. 6. False trigger correction circuit.

The false trigger correction circuit is based on the following logic. The nodes are rank-ordered, with A assigned the highest priority, followed by B, and then C. If the warning bits of the sensor nodes at A and B are same, or the warning bits of A and C are the same, or if all three warning bits at A, B, and C are the same, the select logic of MULTIPLEXER 1 becomes ‘1’.

There are two operational modes for the system, namely, normal mode and test mode. In normal mode, the test signal is ‘0’, and under the circumstances described, A is selected as the output. The remaining case is when warning bit of A is different from B and C, but the warning bits of B and C are the same. With test signal 0, and B having priority over C in normal mode, B is transmitted as the output, since the select logic of MULTIPLEXER 1 is ‘0’.

In test mode, the lower priority data i.e., the test data with the same warning status is transmitted and checked at the receiver end. For example, if the warning status bits of A and B are same, then MULTIPLEXER 4 selects B for transmission, as select to MULTIPLEXER 4 is ‘1’. If the warning status bits of A, B and C are the same, B is selected

for transmission.

In the complementary case, when A is not consistent with either B or C, but B and C are consistent, B is transmitted in the normal mode, and test data C is transmitted in the test mode, as the select, i.e., test signal for MULTIPLEXER 3 is '1'. The output verified by the false trigger correction block is transmitted to the base station in the city.

The position of the sensors is verified by pre-sensing, wherein the top sensor is expected to respond before the bottom sensor. The highest non-zero address has to pass through level 01 if it has to rise from 00 to 10. This can be recognized by a subtract or and a comparator, as the difference between consecutive water levels should not exceed '1'. These self-checking techniques are very effective in increasing the reliability of the flood prediction system.

Battery status circuit

The battery status circuit is shown in the Fig. 7. The function of this circuit is to determine whether the battery is working or needs to be replaced. Whenever the battery supply voltage is 11.3 V or greater, the output of the upper and lower comparators will be '1', i.e., S0S1=11 is transmitted. At the base station, through a demultiplexer, the "battery working" signal is set to '1'. When the supply voltage is less than 11.3 V and more than 10.2 V, the upper comparator output is '0', while the lower comparator is '1', i.e., S0S1=01, therefore replace = '1', which is an indication that the battery needs to be replaced.

The voltage cannot be higher than 11.3 V and less than 10.2 V, otherwise "invalid" becomes '1', which can be used as a self-check for battery status circuit. Finally when the supply voltage goes below 10.2 V, both upper and lower comparators output '0', asserting "not working" to '1' at the base station. This indicates that the battery is no longer useful, i.e., "not working." Different colored LED's can be used to represent each condition.

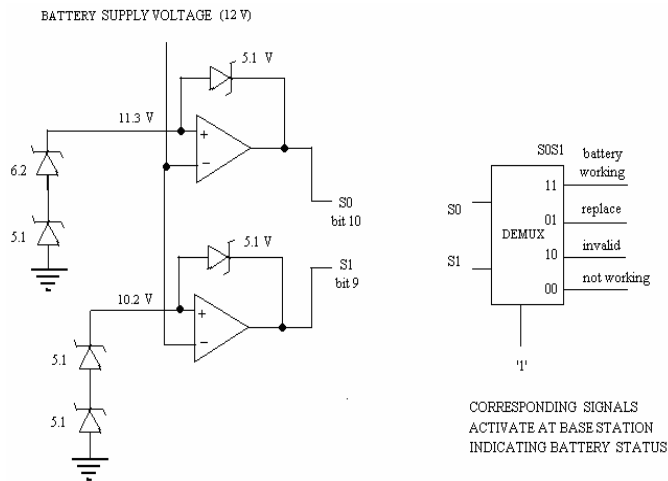

Fig. 7. Battery status circuit

Sensor position check circuit

The position of the sensors is checked by the circuit depicted in Fig. 8. In this circuit, current is passed through a thin wire that passes through the adjacent sensors from one end to the other end. If the current reaches the other end, "sensor position" is set to '1', i.e., the SP bit is set to '1' and transmitted. If current cannot reach the other end, it indicates that the sensors are not in position, i.e., the wire is discontinuous, meaning sensor has been displaced. SP=0 is transmitted in this case, and repair is necessary. Here 6V appears at the inverting input of the zero crossing detectors.

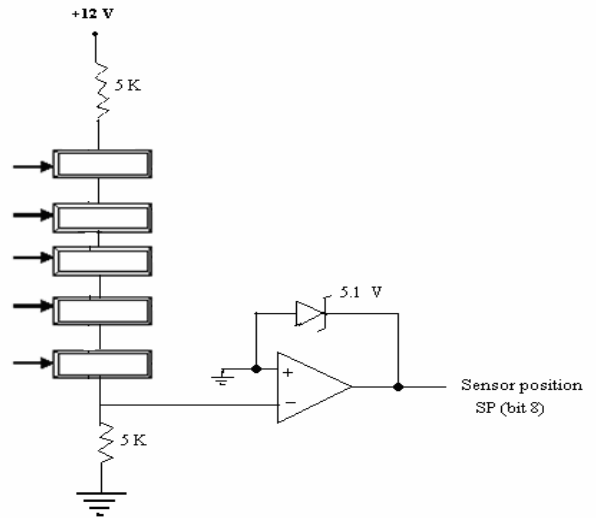

Fig. 8. Sensor position check circuit

III. FPGA IMPLEMENTATION

Hardware prototyping of the system was carried out on an ALTERA FPGA board, as depicted in Fig. 9. The logic of the flood prediction system logic was functionally verified in VHDL using Mentor Graphics. The code was then synthesized using Quartus 2, which is Altera's design tool. The design can be implemented on an Altera Cyclone DE2 FPGA board. As shown in Fig. 9, the circuit has inputs of 14 bits each from the two sensor nodes B and C. These inputs are set to specific predefined values. The clock input, input from the internal pressure sensors, reset bit, battery status bits, sensor position bits, test input, and threshold bits constitute the other inputs for the design. The output is a 14-bit value generated after going through the internal processes of comparing and generating the correct warning bit. The output pins are assigned to LEDs to facilitate checking the correctness.

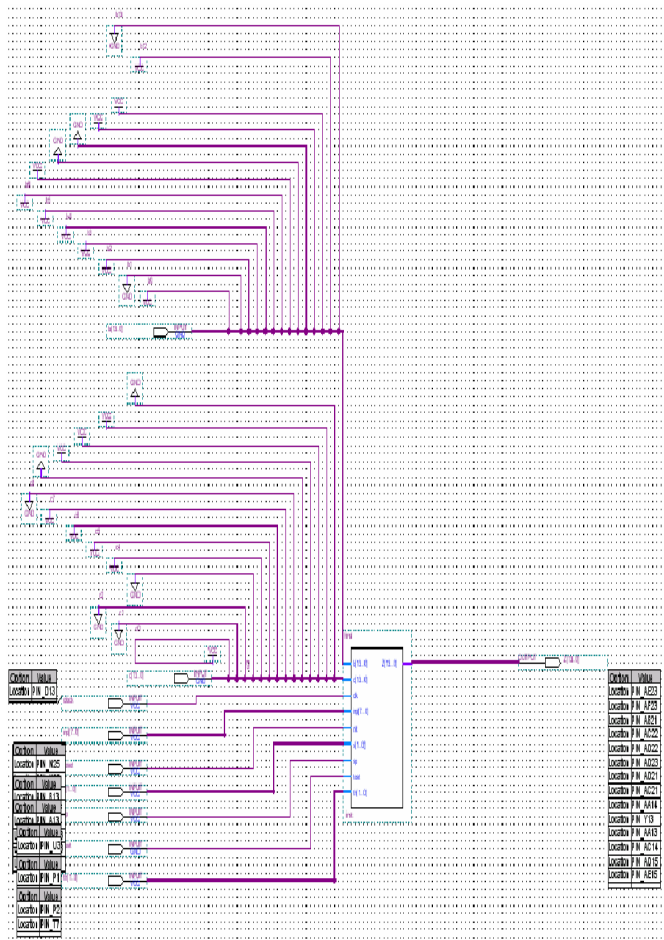

Fig. 9. FPGA prototyping of the design using Altera FPGA.

We can test for the different test cases described in Tables 1 and 2. They show two different cases, one when the test signal that is used by false trigger correction block is not enabled, and another case when it is enabled.

TABLE 1
Output Z for test = 0

A= 01110111011001 B= 011100111111110 C= 011100111110010	A= 11110000010010 B= 011100111111101 C= 011100111110001
z = A (highest priority among A,B,C)	z = B (higher priority among B,C) Note that the false triggering of 'A' was prevented from being transmitted.

Three different data input readings will be received from the three sensors, one from the base node and two from the two sensor nodes. These readings can be falsely triggered or correct values. In Table 1, where the test signal has not been activated, the first column shows that when we have three correct values 'A' will be transmitted to the base station, as

'A' has higher priority. When there is a false trigger at 'A', the transmission of 'A' is avoided and 'B' is transmitted, as it has higher priority than 'C'.

TABLE 2
Output Z for test = 1

A= 01110111011001 B= 011100111111110 C= 011100111110010	A= 11110000010010 B= 011100111111101 C= 011100111110001
z = B (lower priority among A,B)	z = C (lower priority among B,C)

Table 2 depicts the case where the test signal has been activated. In the case of normal transmission of data without any false triggering, 'B' is transmitted, which has lower priority between 'A' and 'B'. When there is a false triggering at 'A', then the data read at 'C' is transmitted, as it has lower priority among 'B' and 'C'. The priorities are assigned based on distance from the base station and the values read. We check at the output side to determine whether the correct outputs are being generated. Fig. 9 shows the setup for second case of Table 1.

IV. CONCLUSIONS AND FUTURE WORK

The flood prediction system described in this paper is capable of predicting floods before they occur. Alerts are generated as necessary, and sent to appropriate emergency management authorities along with data on water level and flow rate. The self-checking circuits employed in the design provide assurance of battery life and correct positioning and operation of the sensors at each node. A false trigger correction block has been included to validate the system operation and avoid false triggering from any of the nodes.

A large number of pressure sensors are required for implementation of the system. However, the overall cost of these sensors is less than a single UV sensor used in existing flood detection systems. The resulting system is simple, inexpensive and easy to install. It consumes low power, and provides autonomous and highly reliable flood prediction.

The programmable logic of the flood prediction system was functionally verified by writing the logic for the different elements required for its implementation, including counters, the false trigger block, and control signals. Verification was carried out in VHDL using Mentor Graphics. The code was synthesized to generate the net list file required for executing it on the FPGA used for prototyping of the system.

The chip is enclosed in a waterproof case and can operate despite high wind speeds. The robustness of the system can be increased by deploying the sensors in locations less likely to encounter foreign objects in the water.

Future extensions to the system include improvements to the short-range communication, and addition of long-range communication capability.

The system can be made self-sufficient provided the

availability of the following capabilities.

a) Detection of approaching clouds that cause heavy rains. This will enable prediction of floods several days before their occurrence.

b) Reasonably accurate knowledge of the probability of flood occurrence at the location.

c) Knowledge of the topography of the river. In locations where the river bank is steep, the probability of flooding is higher.

Such information will allow early warning of impending floods, which provides invaluable time for evacuation and other preventative measures. Coupled with automated telephone warning systems and surveillance equipment, the system can autonomously provide alerts, while collecting data on the damage incurred. This data can guide future emergency management efforts [9,10].

REFERENCES

- [1] FEMA, Homepage for Federal Emergency Management Agency, Protective measures, <http://www.fema.gov/>.
- [2] J. F. Galantowicz. High-resolution flood mapping from low-resolution passive microwave data. Proc. of IEEE Int'l. Geoscience and Remote Sensing Symposium (IGARSS '02), Publication Date: 2002, Volume: 3, On page(s): 1499- 1502.
- [3] Siegel, H., M. Gerth and M. Gade, Remote Sensing of the Pomeranian Bight by Different Optical and Microwave Sensors During the Oder Flood in August 1997, IEEE 1999 International Geoscience and Remote Sensing Symposium Proceedings, Volume 1, pages 308-311.
- [4] Waldemar Nawrocki , "Measurement systems and sensors" ,pp. 41-52, Artech House, Incorporated, 2005.
- [5] Basics of Sensors, Piezoelectric Sensors, <http://ccrma.stanford.edu/CCRMA/Courses/252/sensors/node7.html>
- [6] Zigbee Alliance, Zigbee specification. www.zigbee.org
- [7] Patrick Kinney, Kinney Consulting LLC, Chair of IEEE 802.15.4 Task Group, Secretary of ZigBee BoD, Chair of ZigBee Building Automation Profile WG, "ZigBee Technology: Wireless Control that Simply Works", dated 2 October 2003.
- [8] Moberg, L, "Battery Test Circuits for a heart pacemaker", U.S patent 4, 715, 38113, 1987.
- [9] FHWA, Federal Highway Administration, US Department of Transportation, "Best Practices for Road Weather Management", version 2.0, http://ops.fhwa.dot.gov/weather/best_practices/CaseStudies/003.pdf
- [10] Wang Qian, Du Yun Xue Huaiping Wu Shengjun, Research on Flood Monitoring System for middle reaches of Yangtze China Using RS and GIS, <http://ieeexplore.ieee.org/iel5/10226/32596/01525387.pdf> arnumber=1525387, IEEE 2005.