



Missouri University of Science and Technology
Scholars' Mine

Electrical and Computer Engineering Faculty
Research & Creative Works

Electrical and Computer Engineering

01 Jan 2001

Applying the Method of Moments and the Partial Element Equivalent Circuit Modeling Techniques to a Special Challenge Problem of a PC Board with Long Wires Attached

Yun Ji

Bruce Archambeault

Missouri University of Science and Technology, archamb@mst.edu

Todd H. Hubing

Missouri University of Science and Technology

Follow this and additional works at: https://scholarsmine.mst.edu/ele_comeng_facwork

 Part of the [Electrical and Computer Engineering Commons](#)

Recommended Citation

Y. Ji et al., "Applying the Method of Moments and the Partial Element Equivalent Circuit Modeling Techniques to a Special Challenge Problem of a PC Board with Long Wires Attached," *Proceedings of the IEEE International Symposium on Electromagnetic Compatibility, 2001*, Institute of Electrical and Electronics Engineers (IEEE), Jan 2001.

The definitive version is available at <https://doi.org/10.1109/ISEMC.2001.950645>

This Article - Conference proceedings is brought to you for free and open access by Scholars' Mine. It has been accepted for inclusion in Electrical and Computer Engineering Faculty Research & Creative Works by an authorized administrator of Scholars' Mine. This work is protected by U. S. Copyright Law. Unauthorized use including reproduction for redistribution requires the permission of the copyright holder. For more information, please contact scholarsmine@mst.edu.

Applying the Method of Moments and the Partial Element Equivalent Circuit Modeling Techniques to a Special Challenge Problem of a PC Board with Long Wires Attached

Yun Ji¹, Bruce Archambeault², Todd H. Hubing¹

¹ University of Missouri-Rolla
Rolla, MO 65409

² IBM
Research Triangle Park, NC 27709

Abstract: This paper investigates a canonical printed circuit board (PCB) problem using both a Method of Moments (MoM) and a Partial Element Equivalent Circuit (PEEC) modeling technique. The problem consists of a PCB populated with three traces. One trace is a signal line and the other two are I/O lines that couple to the signal line and extend beyond the boundary of the board. Although the MoM code was a frequency domain code and the PEEC code was a time-domain code, good agreement was achieved in both the time-domain and the frequency-domain.

I. INTRODUCTION

A number of challenging EMC modeling problems have been proposed by the IEEE/EMC Society TC-9 Committee.¹ This set of problems was created to highlight the strengths and weaknesses of various computational modeling techniques and to evaluate modeling software for EMC applications. One of the key ways to validate a given modeling result is to apply two completely different techniques to the same problem and obtain the same answer.

This paper investigates one of the most difficult challenge problems, first introduced at the 1998 IEEE/EMC Symposium. Solutions using the Finite-Difference Time-Domain (FDTD) method [1], the Partial Element Equivalent Circuit (PEEC) method [2], the Transmission-Line (TLM) method [3], and the hybrid FEM/MoM method [4] have been presented by researchers. However, no consensus had been reached on the solution. In this paper, two completely different modeling techniques are used to model this problem. Good agreement has been

obtained using these techniques to calculate the time-domain voltage at three places on the PCB and the frequency-domain radiated field at 10 meters.

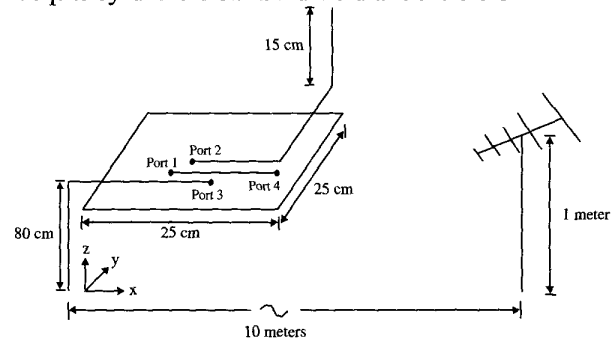

Figure 1. The 3D view of a PCB geometry

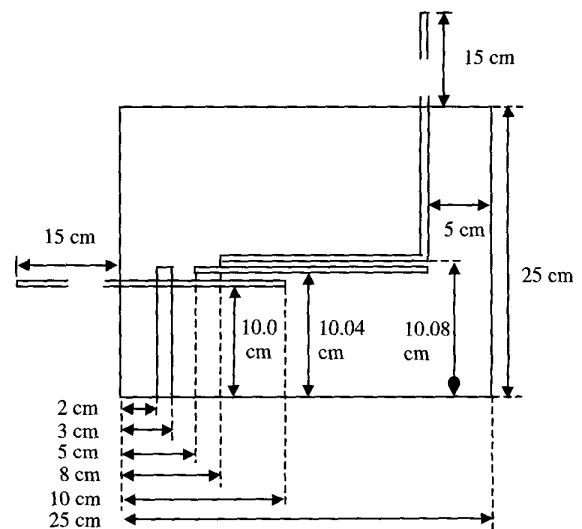

Figure 2. Top view of the PCB geometry

¹ The TC-9 challenge problems can be found on the web at <http://www.emcs.org/tc9>.

II. PROBLEM DESCRIPTION

The problem geometry is shown in Figure 1 and Figure 2. Traces are terminated at Ports 2, 3, and 4 by 55-ohm resistors. Port 1 is the source position. The source is a voltage source with a 10-ohm resistor in series. As shown in Figure 3, the voltage waveform is a trapezoidal waveform with a magnitude of 1.0 volt, a duration of 20 ns, and a risetime of 0.3 ns. The antenna is 10 meters away from the board and 1 meter above the end of the 80-cm trace.

The primary challenge of this problem is the mixed physical scales. The width of the traces is 0.2 mm and they are spaced by 0.2 mm. On the other hand, the board size is 25 cm \times 25 cm and the total length of the I/O traces is more than 100 cm.

To simplify the problem, the relative permittivity of the dielectric is set to 1.0. There is a gap on the board ground plane in the original problem. In this study, the gap is removed to simplify the analysis. There is no infinite ground plane below the board and the antenna.

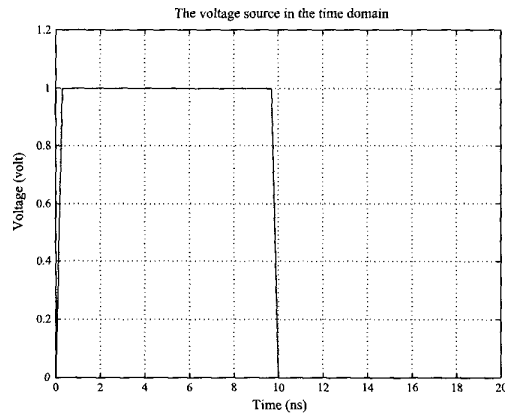

Figure 3. Voltage waveform at Port 1

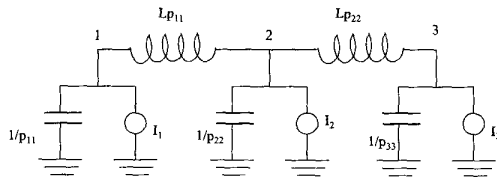

Figure 4. Decoupling transfer function for various capacitor distribution densities

III. NUMERICAL RESULTS

PEEC is based on an integral equation formulation. The structures to be modeled are divided into electrically small elements. The coupling between each element is described as an equivalent circuit Figure 4. Once a matrix of equivalent circuits has been developed, a SPICE-like circuit solver is used to solve for the response of the system. Since the solution is a circuit-based solution, individual circuit elements, such as resistance, capacitance, and inductance can be easily added to any set of elements or nodes.

For these models, an equivalent series inductance of 2 nH was added to account for the via and pad inductance of the resistor connections. This inductance becomes the significant at high frequencies.

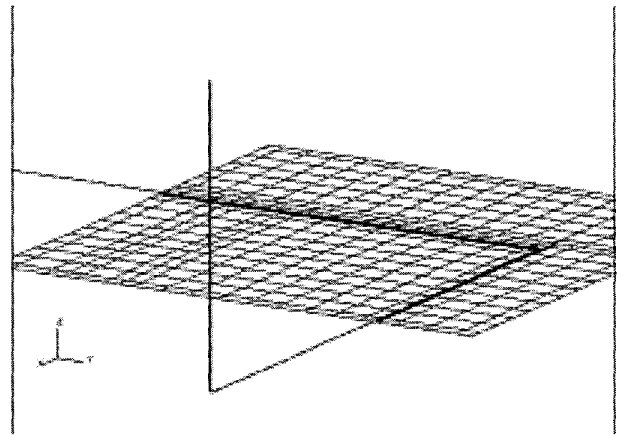

Figure 5. Grids used on the board by PEEC

The grid size was set to insure at least 20 grid points per wavelength. The grid size directly under the microstrip traces was reduced further to better define the rapidly changing currents in these areas. Figure 5 shows the grid used for the PEEC analysis. PEEC codes create an equivalent circuit model that can be analyzed in either the time or frequency domain. This feature of PEEC allows the analysis to use the domain best suited to the problem and can eliminate extra post-processing steps. For this challenge problem, both analysis domains were used. The PEEC models took about 2 minutes per frequency to run on an IBM RS6000 workstation.

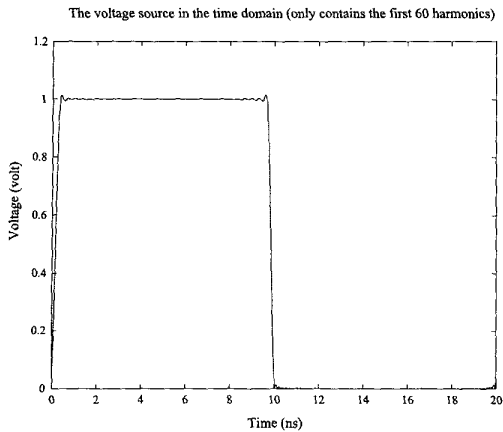

Figure 6. The voltage waveform at Port 1 in the time domain after truncating the harmonics greater than 3.0GHz

The MoM analysis was performed using EMAP5, a hybrid FEM/MoM code developed at University of Missouri-Rolla [5]. EMAP5 is a frequency-domain code so the voltage source waveform was transformed from the time domain to the frequency domain using an FFT. The first 60 harmonics were used to complete the transform. As shown in Figure 6, the first 60 harmonics represent the original waveform very well. Triangular basis functions (RWG functions) [6] were employed to approximate surface currents. A fine mesh was used around the four ports as shown in Figure 7 to ensure the accuracy of the results. Figure 8 shows the triangular mesh on the surface of the board. In total, 3,720 triangular elements were used to discretize the geometry. The total number of unknowns was 4,834. The problem required 373 MB of computer memory to store the MoM matrix. The total memory required to run this problem was 970 MB. It took 90 minutes to compute each frequency point on a Pentium 550 MHz PC including the 20 minutes spent reading and writing to the hard disk. The memory requirement could have been reduced to less than 400 MB by using a Gaussian elimination method to solve the MoM matrix equation. However, this solver would have been much slower and therefore was not used for this study.

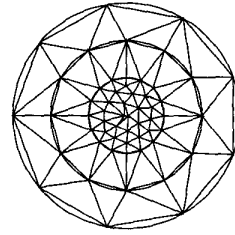

Figure 7. The triangular mesh around one port used by EMAP5

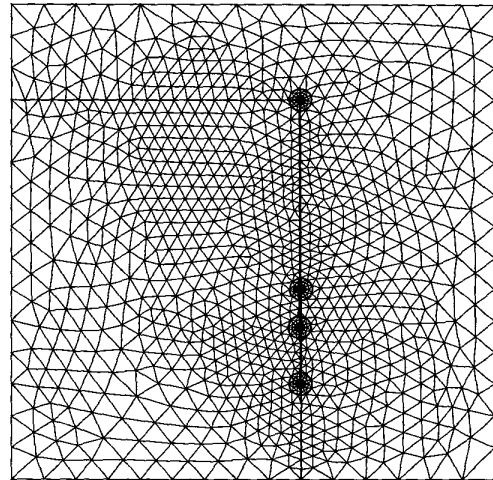

Figure 8. The triangular mesh on the surface of the board used by EMAP5

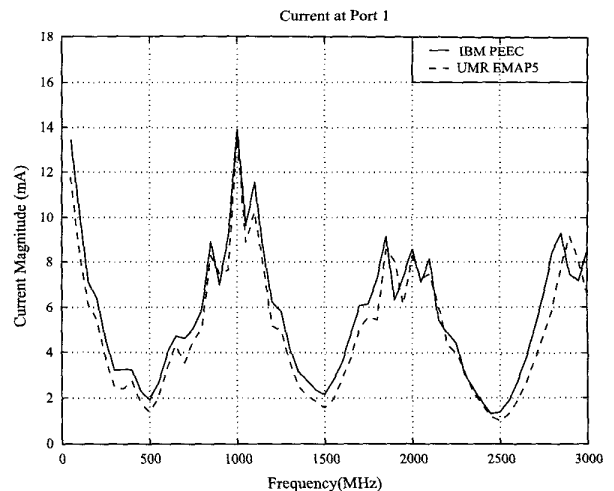

Figure 9. The current magnitude at Port 1 due to a 1-volt excitation at each 50-MHz harmonic

In order to have any chance to calculate the coupled or radiated fields accurately, it is important to be able to determine the current on the driven trace. Figure 9 shows the current at Port 1 obtained using a 1-volt excitation at each of the first 60 50-MHz harmonics. There was very good agreement between the results obtained using the PEEC and MoM codes. The difference in the calculated currents was generally less than 2 dB although there was a slight shift in the highest resonant frequency. The resonance shift was likely due to the 2-nH via inductance that was added to the load in the PEEC model, but not to the MoM model.

Using the time-domain voltage source excitation shown in Figure 3, the voltage waveforms at Ports 2, 3 and 4 were calculated using both methods. The results are shown in Figures 10, 11 and 12, respectively. The agreement between the results obtained using MoM and PEEC is good except at Port 3, where there are some oscillations in MoM results while PEEC results are more damped. This is probably due to the way results were converted between the time and frequency domains. The MoM code was essentially modeling a 50-MHz square-wave excitation. The PEEC code was modeling a single 10-ns pulse.

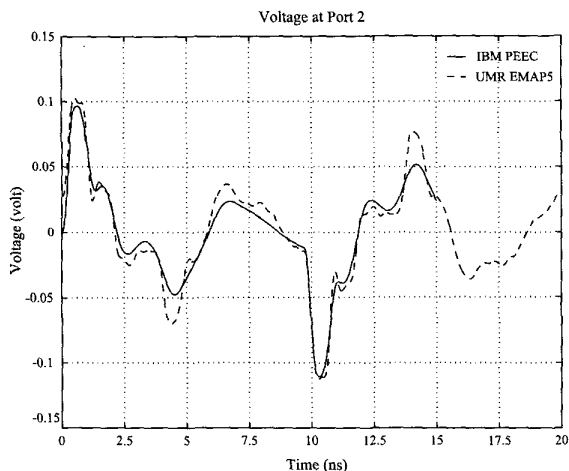

Figure 10. The voltage at Port 2 in the time domain

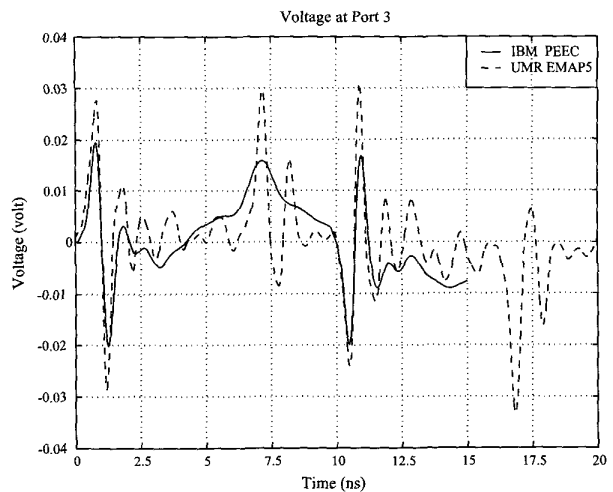

Figure 11. The voltage at Port 3 in the time domain

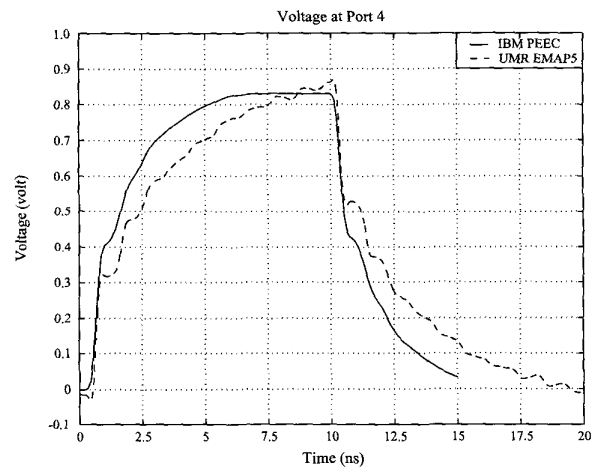

Figure 12. The voltage at Port 4 in the time domain

Figures 13 and 14 show the maximum vertical electric field and total electric field 10 meters from the board with a 1-volt excitation at each 50-MHz harmonic. The agreement between the PEEC results and the MoM results is excellent.

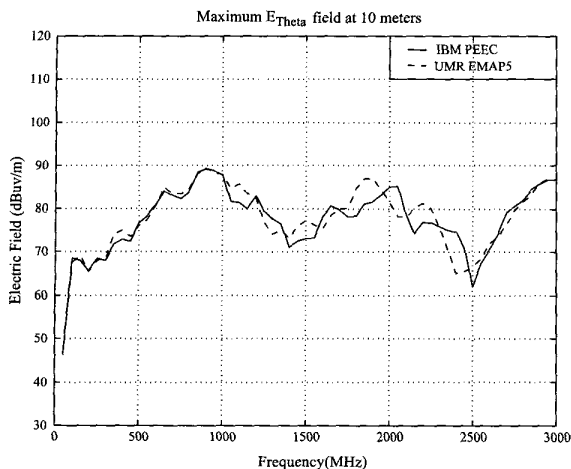

Figure 13. The maximum vertical electric field 10 meters from the board

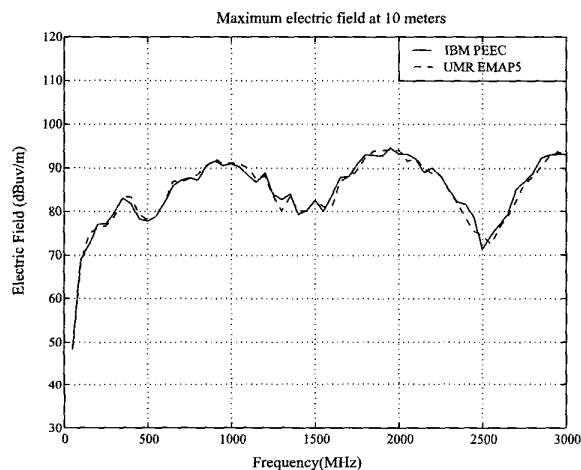

Figure 14. The maximum total electric field 10 meters from the board

IV. CONCLUSIONS

This paper compared the results obtained for a canonical PCB problem using PEEC and MoM codes. Good agreement was obtained in both the time and frequency domains. Although both techniques provide essentially the same results, there are major differences in the way the calculations are done. Each method has advantages and disadvantages. The best method to use for a particular problem depends on many factors.

Small details of the model can have a significant effect on the results. Several iterations were required in order to be sure that both codes were actually modeling the same problem. At the time of publication, there were still a few details (e.g. via inductance and square-wave vs. pulse excitation) that were causing the results to differ. Additional work needs to be done in order to evaluate the effect of adding the gap and the dielectric that were originally part of the problem specification.

REFERENCES

- [1] J. Mix, G. Haussmann, M. Picket-May and K. Thomas, "EMC/EMI Design and Analysis Using FDTD," *Proceedings of the 1998 IEEE International Symposium on Electromagnetic Compatibility*, vol. 1, pp. 177-181, Denver, CO, August 1998.
- [2] A. E. Ruehli and A. C. Cangellaris, "Application of the partial Element Equivalent Circuit (PEEC) method to realistic printed circuit board problem," *Proceedings of the 1998 IEEE International Symposium on Electromagnetic Compatibility*, vol. 1, pp. 182-187, Denver, CO, August 1998.
- [3] C. Christopoulos, "Application of the TLM Method to Equipment Shielding Problems," *Proceedings of the 1998 IEEE International Symposium on Electromagnetic Compatibility*, vol. 1, pp. 182-187, Denver, CO, August 1998.
- [4] Y. Ji, J. Chen, T. H. Hubing, and J. L. Drewniak, "Application of a hybrid FEM/MOM method to a canonical PCB problem," *Proceedings of the 1999 IEEE International Symposium on Electromagnetic Compatibility*, vol. 1, pp. 91-96, Seattle, WA, August 1999.
- [5] Y. Ji and T. H. Hubing, "EMAP5: A 3D hybrid FEM/MoM code," to appear in the *Applied Computational Electromagnetics Society Journal*, Mar. 2000.
- [6] S. M. Rao, D. R. Wilton, and A. W. Glisson, "Electromagnetic scattering by surfaces of arbitrary shape," *IEEE Trans. on Antennas and Propagat.*, vol. 30, pp. 409-418, May 1982.