



Missouri University of Science and Technology
Scholars' Mine

Electrical and Computer Engineering Faculty
Research & Creative Works

Electrical and Computer Engineering

01 Jan 2000

Adaptive Critic Based Neurocontroller for Turbogenerators with Global Dual Heuristic Programming

Ganesh K. Venayagamoorthy
Missouri University of Science and Technology

Donald C. Wunsch
Missouri University of Science and Technology, dwunsch@mst.edu

Ronald G. Harley

Follow this and additional works at: https://scholarsmine.mst.edu/ele_comeng_facwork



Part of the [Electrical and Computer Engineering Commons](#)

Recommended Citation

G. K. Venayagamoorthy et al., "Adaptive Critic Based Neurocontroller for Turbogenerators with Global Dual Heuristic Programming," *Proceedings of the IEEE Power Engineering Society Winter Meeting, 2000*, Institute of Electrical and Electronics Engineers (IEEE), Jan 2000.

The definitive version is available at <https://doi.org/10.1109/PESW.2000.849974>

This Article - Conference proceedings is brought to you for free and open access by Scholars' Mine. It has been accepted for inclusion in Electrical and Computer Engineering Faculty Research & Creative Works by an authorized administrator of Scholars' Mine. This work is protected by U. S. Copyright Law. Unauthorized use including reproduction for redistribution requires the permission of the copyright holder. For more information, please contact scholarsmine@mst.edu.

Adaptive Critic Based Neurocontroller for Turbogenerators with Global Dual Heuristic Programming

***G.K.Venayagamoorthy Member, IEEE**

Electronics Engineering Department,
ML Sultan Technikon, POBox 1334 Durban 4000 South Africa
Tel. No. +27 82 882 3718 Fax. No. +27 31 308 5379
gkumar@ieee.org

D.C.Wunsch II Senior Member, IEEE

Computer Engineering Department
University of Missouri-Rolla
USA
dwunsch@ece.umar.edu

***R.G.Harley Fellow, IEEE**

School of Electrical and Computer Engineering
Georgia Institute of Technology Atlanta GA 30332-0250
USA
ron.harley@ee.gatech.edu

*Electrical Engineering Department University of Natal Durban 4041 South Africa

Abstract: Turbogenerators are nonlinear time varying systems. This paper will present the design of a neurocontroller for such a turbogenerator that augments/replaces the traditional Automatic Voltage Regulator (AVR) and the turbine governor using a novel technique based on the Adaptive Critic Designs (ACDs) with emphasis on Global Dual Heuristic Programming (GDHP). Simulation results are presented to show that the neuro-controller derived with the GDHP approach is robust and its performance is better when compared with that derived with other neural network technique, especially when system conditions and configuration changes.

Keywords: Artificial Neural Networks, Power Plant Control, Adaptive Critic Designs.

I. INTRODUCTION

Turbogenerators are highly complex, non-linear, fast acting, multivariable systems with dynamic characteristics that vary as operating conditions change. As a result, the outputs have to be coordinated to satisfy the requirements of the power system operation. The effective control of turbogenerators is important since these machines are responsible for ensuring the stability and the security of the electrical network. Conventional AVRs and turbine governors are designed to control, in some optimal fashion, the turbogenerator around one operating point; at any other point the generator's performance is degraded [1].

Artificial neural networks (ANNs) are good at identifying and controlling complex nonlinear systems [2]. They are suitable for multi-variable applications, where they can easily identify the interactions between the inputs and outputs. It has been shown that a multilayer feedforward neural network using deviation signals as inputs can identify [3] the complex and nonlinear dynamics of a single machine infinite bus configuration with sufficient accuracy to design a controller. Numerous publications have reported on the design of ANN controllers for turbogenerators, and presented both simulation and experimental results showing that ANNs have the potential to replace traditional controllers [4,5,6].

ACDs are a powerful form of reinforcement control [7] and GDHP is considered the most advanced form of ACDs [8]. ACDs can be used to maximize or minimize any utility function, such as total energy or trajectory error, of a system over time in a noisy unstationary environment. Numerous papers [4,5,6] have reported on neural network controllers for turbogenerators based on supervised learning. Unlike supervised learning, ACDs do not require that desired control signals be known. Instead, feedback is obtained based on a critic network which learns the relationship between a set of control signals and the corresponding strategic utility function. A GDHP system involves two sub-networks, namely the Action network (controller) and the Critic network. The critic network learns to approximate the cost-to-go (the function J of Bellman's equation in dynamic programming) and its derivatives, thus making GDHP design a powerful neurocontroller.

In this paper, simulation results on a single machine infinite bus system will be presented to show that the neurocontroller derived with the GDHP approach is robust and hence online training is less required and therefore less computationally demanding for real time implementation compared to other neural network techniques [4,5,6]. The results are compared against a traditional controller and a Continually Online Trained (COT) ANN controller under different system configurations and operating points. The results with this neurocontroller show that it is possible to operate turbogenerators close to their steady state stability limits and still safe ride through severe transients such as three phase short circuits.

II. POWER SYSTEM MODEL

A 3 kW micro-alternator with per-unit parameters typical of those expected of 30 – 1000 MW generators [9], with traditional governor and excitation controls connected to an infinite bus through a transmission line, shown in Fig. 1, is used in this study. The non-linear time-invariant system equations are of the form:

$$\dot{x} = f(x, u) + g(x) \quad (1)$$

where $g(x)$ contains the non-linear terms.

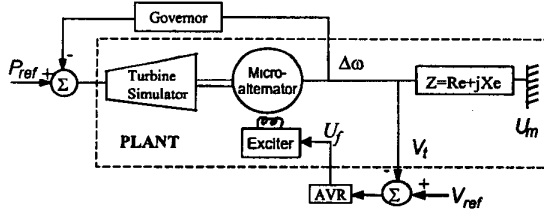

Fig. 1. The single machine infinite bus configuration

The traditional AVR and excitation system, the turbine simulator and governor system and the micro-alternator with transmission line are represented in state space by a second, fourth and seventh order equations respectively. The mathematical implementations of these state space equations are carried out in the MATLAB/SIMULINK environment [4].

III. ADAPTIVE CRITIC DESIGNS

Adaptive Critic Designs are neural network designs capable of optimization over time under conditions of noise and uncertainty. A family of ACD was proposed by Werbos [7] as a new optimization technique combining together concepts of reinforcement learning and approximate dynamic programming. The ACD consists of two networks called the Critic and the Action which are connected together directly (Action-dependent designs) or through an identification model of a plant (Model-dependent designs). There are three classes of implementations of ACD called Heuristic Dynamic Programming (HDP), Dual Heuristic Dynamic Programming (DHP), and Globalized Dual Heuristic Dynamic Programming (GDHP), listed in order of increasing complexity and power [8].

A. Heuristic Dynamic Programming (HDP)

The critic network estimates the function J (cost-to-go) in the Bellman's equation of dynamic programming, expressed as follows:

$$J(t) = \sum_{k=0}^{\infty} \gamma^k U(t+k) \quad (2)$$

where γ is a discount factor for finite horizon problems ($0 < \gamma < 1$), and $U(\cdot)$ is the utility function or local cost. The critic network is trained forward in time, which is of great importance for real-time operation. The critic network tries to minimize the following error measure over time

$$\|E_1\| = \sum_t E_1^2(t) \quad (3)$$

$$E_1(t) = J(\Delta Y(t)) - \gamma J(\Delta Y(t+1)) - U(t) \quad (4)$$

where $\Delta Y(t)$ stands for either a vector of observables of the plant (or the states, if available).

B. Dual Heuristic Programming

DHP has a critic network that estimates the derivatives of J with respect to the vector ΔY . The critic network learns minimization of the following error measure over time:

$$\|E_2\| = \sum_t E_2^T(t) E_2(t) \quad (5)$$

where

$$E_2(t) = \frac{\partial J[\Delta Y(t)]}{\partial \Delta Y(t)} - \gamma \frac{\partial J[\Delta Y(t+1)]}{\partial \Delta Y(t)} - \frac{\partial U(t)}{\partial \Delta Y(t)} \quad (6)$$

where $\partial(\cdot)/\partial \Delta Y(t)$ is a vector containing partial derivatives of the scalar (\cdot) with respect to the components of the vector ΔY . The critic network's training is more complicated than in HDP since there is need to take into account all relevant pathways of backpropagation.

C. Global Dual Heuristic Programming (GDHP)

GDHP minimizes the error with respect to both J and its derivatives. While it is more complex to do this simultaneously, the resulting behavior is expected to be superior. Training the critic network in GDHP utilizes an error measure which is a combination of the error measures of HDP and DHP, eqs. (3) and (5) respectively.

The critic network in a straightforward GDHP design is shown in Fig. 2. The critic adaptation in a simplified GDHP design is illustrated in Fig. 3. $R(t)$ is a vector of the observables of the plant.

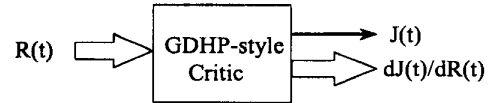

Fig.2. Critic network in a straightforward GDHP design

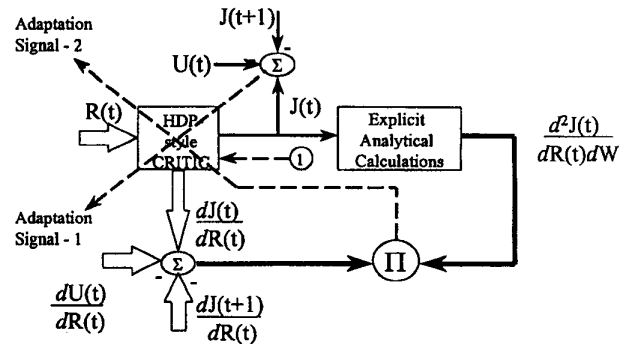

Fig. 3. Critic adaptation in a simplified GDHP design

This paper compares GDHP model dependent design against the results obtained using a traditional PID controller [10] and a COT ANN controller [4]. The model that is used for the plant (Fig. 1) in this paper is an ANN model/identifier [3]. The GDHP model dependent design is illustrated in Fig. 4. The details on the training of the critic network and the action network are given in [8].

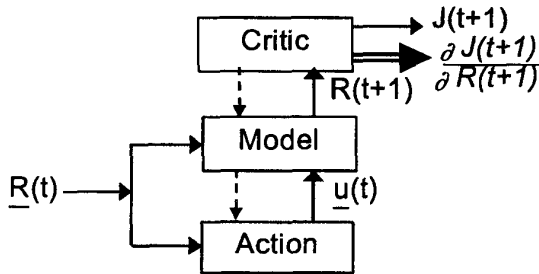

Fig. 4. GDHP model dependent design

IV. SIMULATION RESULTS

Once the critic network's and action network's weights have converged, the action network is connected to the plant (Fig. 1) as shown in Fig. 5.

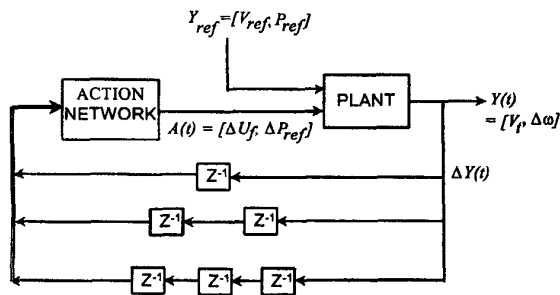

Fig. 5. Trained action network connected for online control of the plant

The dynamic and transient operation of the action network is compared with the operation of a traditional PID controller (AVR and turbine governor) and a COT ANN controller [4] under two different conditions: $\pm 5\%$ desired step changes in the terminal voltage setpoint, and a three phase short circuit on the infinite bus. Each of these is investigated for the turbogenerator operating at different power factors and transmission line configurations.

Typical results are shown in Figs. 6 to 9. Figs. 6 and 7 show the performance of the different controllers for $\pm 5\%$ desired step changes in the terminal voltage with the turbogenerator operating at 1 pu real power (P) and 0.85 lagging power factor (pf) with transmission line impedance $Z = 0.02 + j 0.4$ pu. Fig. 8 shows a turbogenerator operating under the same conditions but experiencing a 50 ms three phase short circuit on the infinite bus. Fig. 9 shows a turbogenerator operating at 1 pu real power and 0.85 lagging pf with transmission line impedance $Z = 0.025 + j 0.6$ pu and experiencing a 50 ms three phase short circuit on the infinite bus.

The results with the conventional, the GDHP and the COT ANN controllers are shown in the diagrams below as CONV, GDHP and COT respectively.

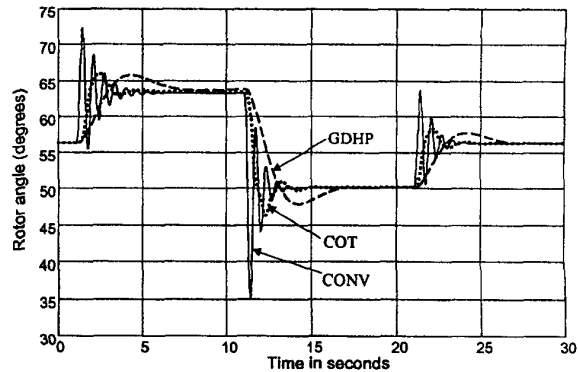

Fig. 6. Rotor angle variation for $\pm 5\%$ step changes in the desired terminal voltage

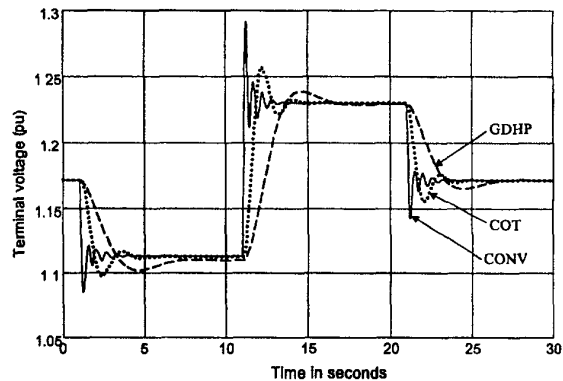

Fig. 7. $\pm 5\%$ step changes in the desired terminal voltage

With step changes in the terminal voltage, the GDHP based controller has a slower rise time than with the conventional and COT ANN controllers. The response of the GDHP based controller for short circuit tests has the best damping compared to all other controllers.

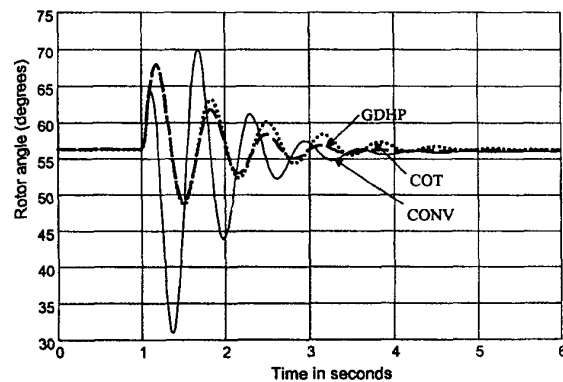

Fig. 8. Rotor angle variations for a 50 ms short circuit on the infinite bus ($P = 1.0$ pu, $pf = 0.85$ lagging, $Z = 0.02 + j 0.4$ pu)

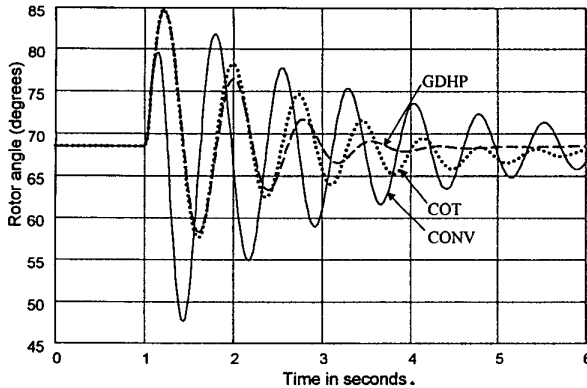

Fig. 9. Rotor angle variations for a 50 ms short circuit on the infinite bus ($P = 1.0$ pu, $pf = 0.85$ lagging, $Z = 0.025 + j 0.6$ pu)

V. CONCLUSIONS

This paper has shown that adaptive critic designs based neural network controllers can control turbogenerators without needing continually online training. The global dual heuristic programming type of ACD based controller has shown an excellent performance with the short circuit tests compared to all controllers. The response of the GDHP based controller to step changes in the terminal has a slower rise than the COT ANN but this response can be improved by using a different utility function and discount factor in the Bellman's equation. This paper has proved that there is a potential for adaptive critic designs based neural network controllers for real time control of turbogenerators.

VI. ACKNOWLEDGEMENT

The authors gratefully acknowledge the financial support from the National Research Foundation, South Africa.

VII. REFERENCES

- [1] B.Adkins, R.G.Harley, "The general theory of alternating current machines", *Chapman and Hall*, London, 1975, ISBN 0-412-15560-5.
- [2] K.J.Hunt, D.Sbarbaro, R.Zbikowski, P.J.Gawthrop, "Neural networks for control systems - a survey", *Automatica*, vol. 28, no. 6, 1992, pp. 1083 - 1112.
- [3] G.K.Venayagamoorthy, R.G.Harley, "A continually online trained artificial neural network identifier for a turbogenerator", *Proceedings of IEEE International Electric Machines and Drives Conference IEMDC' 99*, Seattle, USA, 9 - 12 May, 1999, pp 404 - 406.
- [4] G.K.Venayagamoorthy, R.G.Harley, "Simulation studies with a continuously online trained artificial neural network controller for a micro-turbogenerator", *Proceedings of IEE International Conference on Simulation*, University of York, UK, 30 September - 2 October 1998, pp 405 - 412.
- [5] G.K.Venayagamoorthy, R.G.Harley, "Experimental studies with a continually online trained artificial neural network controller for a turbogenerator", *Proceedings of International Joint Conference on Neural Networks, IJCNN' 99*, Washington, DC USA, 10 - 16 July 1999.
- [6] D.Flynn, S.McLoone, G.W.Irwin, M.D.Brown, E.Swidbank, B.W.Hogg, "Neural control of turbogenerator systems", *Automatica*, vol. 33, no. 11, 1997, pp 1961 - 1973.
- [7] P.J.Werbos, 'Approximate dynamic programming for real-time control and neural modeling', in *Handbook of Intelligent Control*, White and

Sofge, Eds., Van Nostrand Reinhold, 1992, ISBN 0-442-30857-4, pp. 493 - 525.

- [8] D.Prokhorov, D.Wunsch, "Adaptive critic designs", *IEEE Trans. Neural Networks*, vol. 8, no. 5, September 1997, pp. 997 - 1007.
- [9] D.J.N.Limebeer, R.G.Harley, M.A.Lahoud, "A laboratory system for investigating subsynchronous resonance", Paper A80-0190-0, *IEEE PES Winter Power Meeting*, New York, USA, Feb 4 - 8, 1980.
- [10] W.K.Ho, C.C.Hang, L.S.Cao, "Tuning of PID controllers based on gain and phase margin specifications", *Proceedings of the 12th Triennial World Congress on Automatic Control*, Sydney, Australia, July 1993, pp. 199-202.

VIII. BIOGRAPHIES

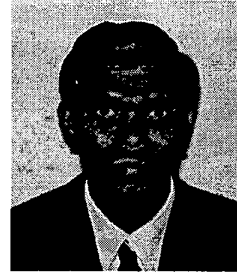

Ganesh K Venayagamoorthy was born in Jaffna, Sri Lanka. He received a BEng (Honours) degree with a First class in Electrical and Electronics Engineering from the Abubakar Tafawa Balewa University, Nigeria, in 1994 and a MScEng degree in Electrical Engineering from the University of Natal, South Africa, in April 1999.

Currently he is pursuing a PhD degree in Electrical Engineering at the University of Natal, South Africa. From 1994 to 1995, he worked as a Computer Engineer at Square One Connet, Maseru, Lesotho. Since 1996, he has been on the Faculty of the Department of Electronics Engineering at the M L Sultan Technikon, Durban, South Africa lecturing Control Systems and Digital Signal Processing. He took up an appointment as a Research Associate for seven months in 1999 at the Texas Tech University, USA. His research interests are in power systems, control systems, signal processing and artificial neural networks. He is a Member of IEEE, SAIEE and an Associate Member of IEE

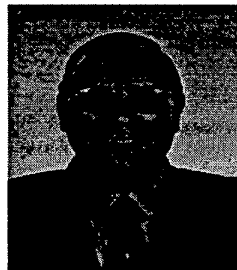

Ronald G Harley was born in South Africa. He obtained a BScEng degree (cum laude) from the University of Pretoria in 1960, and a MScEng degree (cum laude) from the same University in 1965. He then moved to Imperial College in London and graduated with a PhD in Engineering from London University in 1969. In 1970 he was appointed to the

Chair of Electrical Machines and Power Systems at the University of Natal in Durban. He has co-authored some 200 papers in refereed journals and international conferences. Ron is a Fellow of the SAIEE, a Fellow of the IEE, and a Fellow of the IEEE. He is also a Fellow of the Royal Society in South Africa, a Fellow of the University of Natal, and a Founder Member of the Academy of Science in South Africa formed in 1994. His research interests are in the dynamic and transient behavior of electric machines and power systems, and controlling them by the use of power electronics and control algorithms.