



Missouri University of Science and Technology
Scholars' Mine

Electrical and Computer Engineering Faculty
Research & Creative Works

Electrical and Computer Engineering

01 Sep 2010

Design of a Conditioner for Smoothing Wind Turbine Output Power

Murali Bottu

Mariesa Crow

Missouri University of Science and Technology, crow@mst.edu

A. Curt Elmore

Missouri University of Science and Technology, elmoreac@mst.edu

Follow this and additional works at: https://scholarsmine.mst.edu/ele_comeng_facwork

 Part of the [Electrical and Computer Engineering Commons](#), [Geology Commons](#), and the [Petroleum Engineering Commons](#)

Recommended Citation

M. Bottu et al., "Design of a Conditioner for Smoothing Wind Turbine Output Power," *Proceedings of the 2010 North American Power Symposium NAPS '10, (2010, Arlington, TX)*, pp. 1-6, Institute of Electrical and Electronics Engineers (IEEE), Sep 2010.

The definitive version is available at <https://doi.org/10.1109/NAPS.2010.5619965>

This Article - Conference proceedings is brought to you for free and open access by Scholars' Mine. It has been accepted for inclusion in Electrical and Computer Engineering Faculty Research & Creative Works by an authorized administrator of Scholars' Mine. This work is protected by U. S. Copyright Law. Unauthorized use including reproduction for redistribution requires the permission of the copyright holder. For more information, please contact scholarsmine@mst.edu.

Design of a Conditioner for Smoothing Wind Turbine Output Power

Murali Bottu, *Student Member, IEEE*, Mariesa L. Crow, *Fellow, IEEE*, and A. Curt Elmore

Abstract--As a result of wind speed intermittency, highly variable wind power output can adversely impact local loads. We propose a conditioner to smooth the variable wind power by utilizing the energy of an ultracapacitor. The conditioner is based on a single phase voltage source inverter (VSI) connected between the grid interconnection point and the ultracapacitor. The shunt VSI injects or absorbs active power from the line to smooth the wind power by utilizing the short term storage capabilities of the ultracapacitor. The ultracapacitor is connected to the DC link through a DC-DC converter, which maintains the voltage of the DC link relatively constant to provide good controllability of the VSI. The control strategies for the conditioner are presented in this paper. The MATLAB simulation results show that the conditioner is efficient in smoothing the wind power. The conditioner design and control will be validated on a Skystream3.7 wind turbine installed at the Missouri University of Science & Technology.

Index Terms-- Power Quality, Power Conditioning, Wind Energy, Inverters, Active Filters, Capacitive Energy Storage, DC-DC Power Conversion.

I. INTRODUCTION

DUE to the price volatility and carbon impact of fossil fuels, wind power generation is rapidly growing as an alternative energy source in many parts of the world. Due to the intermittency of wind speed, wind turbine output power can be highly variable. Power fluctuations from the wind turbine may cause severe power quality problems when connected to the grid. The large variability in wind turbine output power can adversely impact local loads that are sensitive to pulsating power, posing a challenge to the use of wind power extensively. The rapid growth of the wind power and its immense potential as a future energy source encourage us to find a way to smooth the intermittent wind power. Energy storage technologies can be used to improve the quality of the wind power [1], [2]. In this paper, we propose the power quality conditioner with the ultracapacitor to smooth the variable wind turbine output power. The short term storage capabilities of the ultracapacitor can be effectively used to smooth the variable wind power to minimize rapid power excursions that may damage sensitive local loads.

This paper presents a power conditioner that has the purpose of smoothing the wind turbine output power. The

power conditioner mainly consists of power converters to shape the injected current at the point of common coupling [3]. The conditioner is based on a single phase shunt connected VSI connected between the grid interconnection point and the ultracapacitor. The shunt VSI injects or absorbs active power from the line to smooth the intermittent wind power by charging or discharging the ultracapacitor [4]. The ultracapacitor is connected to the DC link through a DC-DC converter. Traditionally, the VSI DC link voltage is maintained relatively constant by the shunt inverter control [5]-[7]. In this application, we use a bidirectional DC-DC converter to maintain the DC link voltage relatively constant[8]. The bidirectional DC-DC converter acts in buck mode during discharge of the DC link and in boost mode during charging to maintain the voltage of the DC link relatively constant to provide good controllability of the VSI.

Control of the injected active power via the shunt inverter is presented in this paper. The VSI controller calculates the compensating active power, which is then synthesized by using the bipolar pulse width modulation (PWM) switching sequence. The reference signal to the shunt inverter controller is obtained from a low pass filter, which has a large time constant. The fluctuating wind power is passed through the low pass filter to get the smoothed reference value. The conditioner ensures the smooth power is available at the grid interconnection point. The simulation results are presented to show the efficiency of the conditioner in smoothing the variable wind turbine output power.



Fig. 1. Skystream wind turbine installed at the authors' university

The power conditioner design and control will be validated on the Skystream3.7 wind turbine installed at the Missouri University of Science and Technology. The installed wind turbine is shown in Fig. 1. The actual output power of the Skystream3.7 wind turbine is shown in Fig.2. The red curve represents the smoothed power to be obtained after the conditioner is connected to the wind turbine.

Bottu and Crow are with the Department of Electrical and Computer Engineering, Missouri University of Science and Technology, Rolla, MO. Elmore is with the Geological Sciences and Engineering Department, Missouri University of Science and Technology, Rolla, MO.

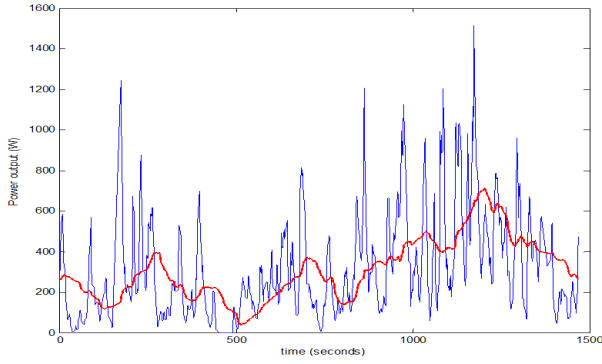

Fig. 2. The actual output power of installed wind turbine (blue) and the target smoothed power (red)

The main contributions of this paper are:

- development of the power quality conditioner design with an ultracapacitor for smoothing the pulsating wind power,
- development of the bidirectional DC-DC converter and the shunt inverter topologies used in the conditioner,
- development of the control schemes for the bidirectional DC-DC converter and the shunt inverter, and
- presenting the simulation results to show the conditioner is efficient in smoothing the wind power.

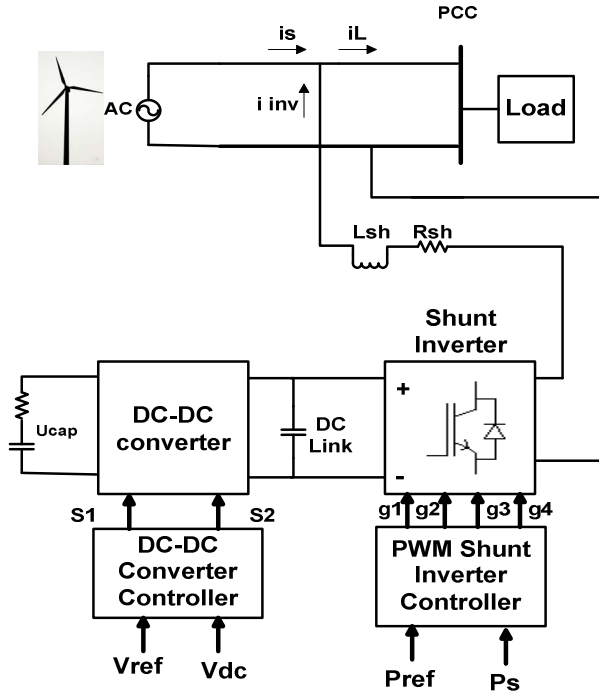

Fig. 3. Power quality conditioner

II. POWER QUALITY CONDITIONER

As shown in Fig. 3, the power quality conditioner consists of a shunt inverter and a bidirectional DC-DC converter. The

VSI acts as a shunt active filter compensating the active power of the wind turbine. The VSI is connected to the line through an RL filter which reduces the unwanted harmonics. The shape of the output current of the conditioner depends on the inductor value of the filter. The value of the resistor and the inductor determines the damping in the circuit. On the other side, the VSI is connected to the DC link capacitor. The DC-DC converter with the ultracapacitor is used to reduce the size of the DC link capacitor and to maintain the voltage of the DC link relatively constant as the ultracapacitor discharges and charges. The bidirectional DC-DC converter charges the ultracapacitor in buck mode by reducing the voltage of the DC link. In the other direction, it acts in boost mode, discharging the ultracapacitor to increase the voltage of the DC link. The power conditioner injects or absorbs active power from the line through the filter to smooth the variable wind turbine output power. The DC link acts as the voltage source for the VSI.

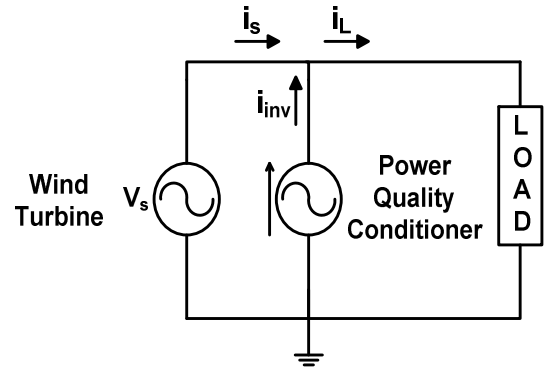

Fig.4. The equivalent circuit of the conditioner

The wind turbine generator produces a constant voltage and variable current output. Fig. 4 shows the equivalent circuit of the power conditioner when integrated to the wind turbine, where V_s is the voltage of the wind turbine generator, i_s is the wind turbine current, i_{inv} is the compensating current supplied by the VSI that can be injected or drawn from the line, and i_L is the smoothed current. The current flow in the system is expressed as

$$i_L(t) = i_s(t) + i_{inv}(t) \quad (1)$$

The relationship between the grid power, wind power and the power from ultracapacitor is given by

$$P_{wind} \pm P_{ucap} = P_{grid} \quad (2)$$

where P_{wind} is the active power of the wind turbine, P_{ucap} is the active power supplied by the ultracapacitor, and P_{grid} is the active power at the grid interconnection point.

The electric model of the variable wind power is designed in SIMULINK. This model generates a constant voltage and a randomly variable current, similar to the characteristics of the wind turbine. To obtain this model, the variable current is injected in series with the constant voltage source. The power generated by this model is similar to the actual power of the installed wind turbine. This model acts as a variable wind turbine output power source for the simulation, to which the conditioner is connected and its performance is evaluated.

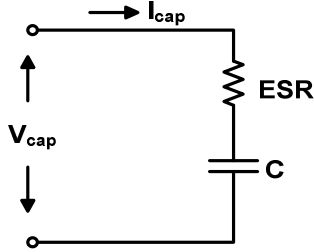

Fig.5. Electric Model of the Ultracapacitor

III. ULTRACAPACITOR ELECTRIC CIRCUIT MODEL

Ultracapacitors are double layered, which increases the storage capability by increasing the surface through a porous electrolyte. Ultracapacitors are mainly used in high peak power situations to improve the reliability of electric power systems. Ultracapacitors have high energy density and large time constants as well. In the charging mode, the terminal voltage of the ultracapacitor increases, whereas in the discharging mode the terminal voltage of the ultracapacitor is decreased. The simple ultracapacitor model shown in Fig. 5 contains only one RC branch, which is composed of an equivalent series resistor (ESR) and a capacitor (C) [9]. The ESR represents the ohmic losses in the ultracapacitor. This ultracapacitor model is used in the converter simulation.

The amount of energy drawn or released by the ultracapacitor is directly proportional to the capacitance value and change in the value of terminal voltage and is given by

$$E_{cap} = \frac{1}{2} c (V_i^2 - V_f^2) \quad (3)$$

where V_i is the initial voltage before charging or discharging starts, V_f is the final voltage after charging or discharging ends.

IV. BIDIRECTIONAL DC-DC CONVERTER

The topology of the bi-directional DC-DC converter is shown in the Fig. 6. The bidirectional DC-DC converter acts a buck converter in one direction and as a boost converter in the other direction [10]-[13]. Power MOSFETS are used as the switching devices in the circuit. The operation of the converter is controlled by the DC link voltage and the voltage of the ultracapacitor. The main purpose of the bidirectional DC-DC converter is to maintain the voltage of the DC link relatively constant at a reference value.

The DC-DC converter operating modes can be divided into four modes as follows:

- Mode 1: The DC-DC converter acts in buck mode, when the voltage of the DC link is above the reference value. In this mode, the DC-DC converter allows the power flow to charge the ultracapacitor.
- Mode 2: The DC-DC converter acts in boost mode, when the voltage of the DC link falls below the reference value. In this mode, the ultracapacitor

energy is discharged to increase the voltage of the DC link.

- Mode 3: When the ultracapacitor is fully charged, the DC-DC converter shuts down to avoid the damaging of the ultracapacitor and the equipment.
- Mode 4: When the ultracapacitor is fully discharged, the conditioner shuts down until charging of the ultracapacitor may resume.

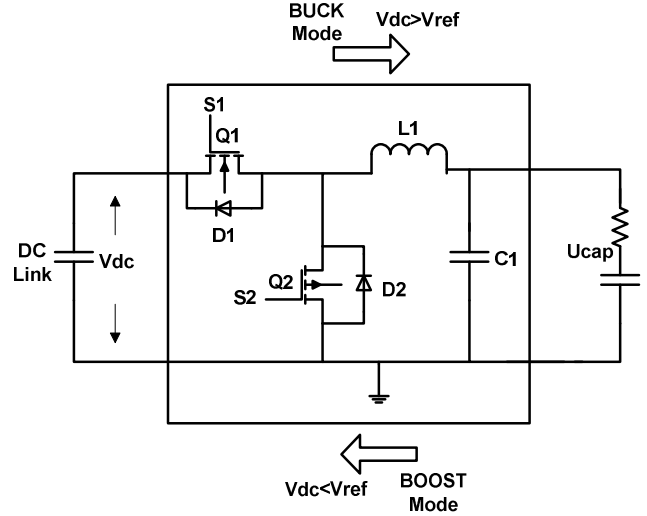

Fig.6. Bidirectional DC-DC Converter

The DC link capacitor is used as an intermediate element between the DC-DC converter and the inverter. The DC link model is:

$$C \frac{dV}{dt} = I_{dc(DC-DC Conv)} - I_{dc(Inv)} \quad (4)$$

where C is the DC link capacitance, $I_{dc(DC-DC Conv)}$ is the current from the DC-DC converter, and $I_{dc(Inv)}$ is the inverter current at the source side.

V. SHUNT INVERTER

A full-bridge IGBT based inverter topology is used in this application. The full-bridge inverter consists of four switching devices, which are connected to form the full-bridge inverter circuit shown in Fig. 7. The gating signals for the IGBTs are obtained by the bipolar pulse width modulation controller. Anti-parallel diodes are connected across the power IGBTs to protect the devices and to provide the power flow in the reverse direction [12], [13]. The voltage source inverter is connected in shunt to the line acts as a current source, injecting or drawing the compensating current from the line [14]. The shunt inverter is connected to the line through a series interference RL filter, which reduces the unwanted harmonics. The filter provides smoothing and isolation from high frequency components. On the other side, the simple full-bridge line connected inverter is connected to the DC link. The injecting current is in phase with the line voltage to have a unity power factor. The output voltage and current waveforms

of the inverter are good, allowing the efficient power transfer to the line from the inverter.

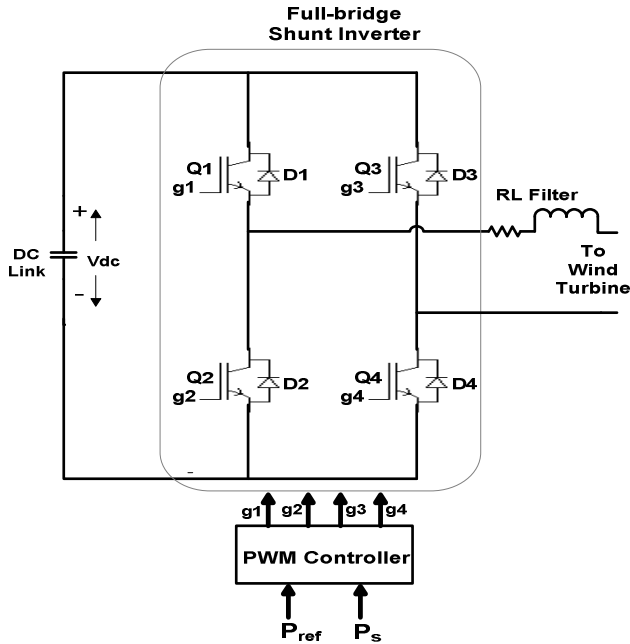

Fig. 7. Circuit diagram of the shunt inverter

The VSI operates in the following two modes:

- Mode 1: When the wind power is greater than the desired value, the converter acts like a rectifier drawing the power from the line and charging the DC link capacitor.
- Mode 2: When the wind power is less than the desired value, then the converter acts like the VSI injecting power into the line by discharging the DC link capacitor.

VI. CONTROL OF THE POWER CONDITIONER

A. Control of the DC-DC Converter

The main objective of the DC-DC controller is to maintain the voltage of the DC link relatively constant at the reference value. The control strategy of the converter is shown in Fig. 8. The DC link voltage is the input for the converter controller. The reference voltage of the DC link is set at 208V. The DC link voltage is subtracted from the reference voltage to obtain the error signal. The generated error signal is passed through a dead band in order to avoid the unnecessary continuous transfer of the energy in the converter. Then, the signal is passed through a PI controller, before it is given to the comparator. Whenever, the voltage of the DC link raises above the reference value, gating signal s1 is given to the MOSFET Q1 and Q2 is turned off. In this case, the DC-DC converter acts in buck mode reducing the DC link voltage. Whenever, the DC link voltage falls below the reference value then, gating signal S2 is given to MOSFET Q2 and Q1 is turned off. In this case, the DC-DC converter acts in boost mode, increasing the DC link voltage. Anti-parallel diodes conduct when the respective switching device is not conducting. Finally, switches are used to select the gating

signals for MOSFETs between the comparator output and zero, depending on the voltage of the DC link.

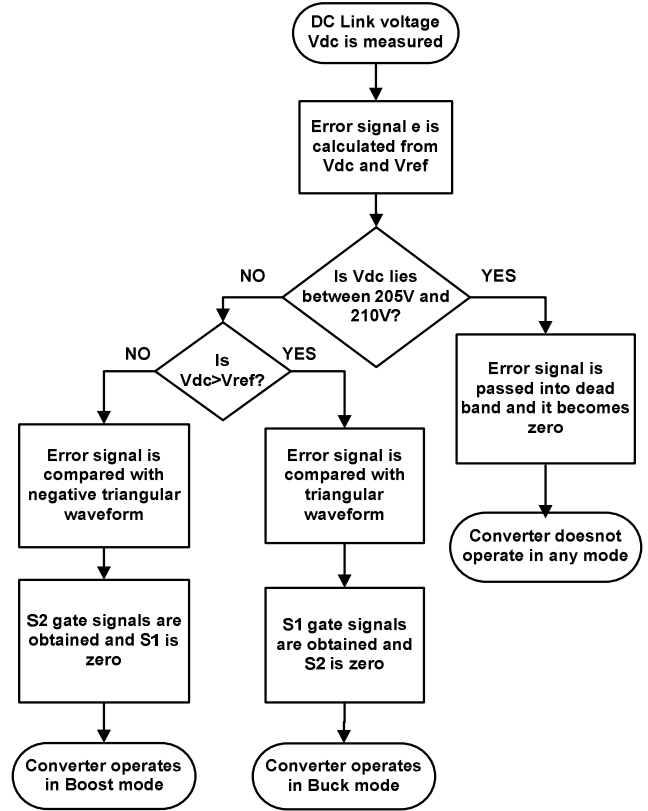

Fig. 8. Flowchart showing the control strategy of the bidirectional DC-DC converter

The switching sequence of the MOSFETS in the DC-DC converter is as follows.

- If $V_{DClink} > V_{ref}$, then Q1 operates with duty cycle obtained from the comparator and Q2 is turned off.
- If $V_{DClink} < V_{ref}$, then Q2 operates with duty cycle obtained from the comparator and Q1 is turned off.

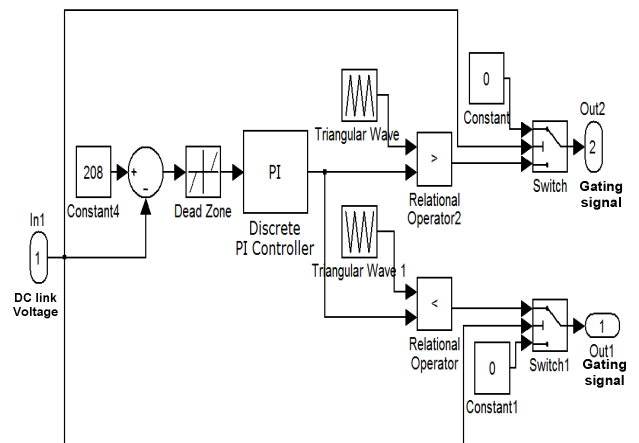

Fig. 9. DC-DC converter controller

The controller for the bidirectional DC-DC converter designed in the MATLAB is shown in Fig. 9. The gating

signals thus obtained are given to the MOSFETs in the converter circuit.

B. Control of the Shunt Inverter

The variable wind power is passed through a low pass filter to get a smoothing reference signal for the inverter controller. The output of the low pass filter is given to the shunt inverter controller as the reference value [15]. The reference signal P_{ref} is obtained as below

$$P_{ref} = \frac{1}{1 + ST} * P_{wind} \quad (5)$$

where T is the time constant of the filter. The smoothing performance of the wind turbine output power depends on the time constant of a low pass filter. The time constant of the low pass filter is in the range of several seconds and is tuned to provide the desired smoothing. The power fluctuation is smoothed by drawing or injecting the difference of the reference power and the variable wind power.

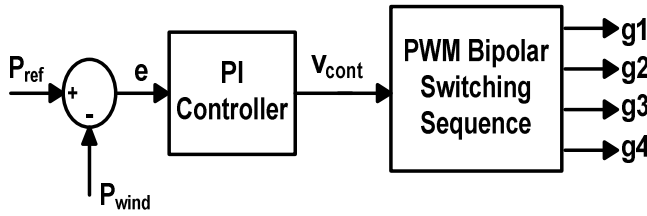

Fig.10. Shunt inverter control scheme

Pulse width modulation (PWM) controller is used to control the switching of the power devices in the full-bridge shunt inverter. The inverter control strategy is as shown in the fig. 10. PWM controller controls the magnitude and phase of the output of the inverter. The advantage of the PWM is both the magnitude and phase of the output can be controlled. Modulation is achieved by comparing the sinusoidal waveform of certain frequency and amplitude to a high frequency triangular carrier waveform. The output frequency of the shunt inverter depends on the frequency of the sinusoidal waveform. The output current waveform shape of the inverter depends on the switching frequency and the filter inductor. The damping in the circuit depends on the filter connected to the inverter output. A bipolar PWM technique is used in this work to control the switching of the inverter. The bipolar switching sequence used is:

- If $V_{cont} > V_{tri}$, then Q1 is on
- If $V_{cont} < V_{tri}$, then Q2 is on
- If $-V_{cont} > V_{tri}$, then Q3 is on
- If $-V_{cont} < V_{tri}$, then Q4 is on.

VII. SIMULATION RESULTS

The model of the proposed conditioner and its control has been developed using the SIMULINK software in MATLAB. Simulations are performed to investigate the performance of

the power quality conditioner and its control. The important parameters used in the simulation are shown in Table I.

TABLE I
SIMULATION PARAMETERS

Ultracapacitor	Nominal capacitance = 94F Initial voltage = 75V ESR = 12.5mΩ
DC-DC Converter	C1 = 9μF L1 = 372μH
DC Link	C = 2200μF Reference Value = 208V
DC-DC Converter Controller	$K_p = .00167$ $K_i = 10$
Shunt Inverter Filter	$R_{sh} = 0.1\Omega$ $L_{sh} = 1mH$

The variable output power of the wind turbine model developed in SIMULINK is shown in Fig. 11. This model was developed to mimic the actual wind turbine active power output shown in Fig. 2. The smoothed reference signal to the inverter controller is shown in Fig. 12. The reference signal is obtained when the variable wind power is passed through a low pass filter with a large time constant. The simulation interval is 1500 sec in both cases.

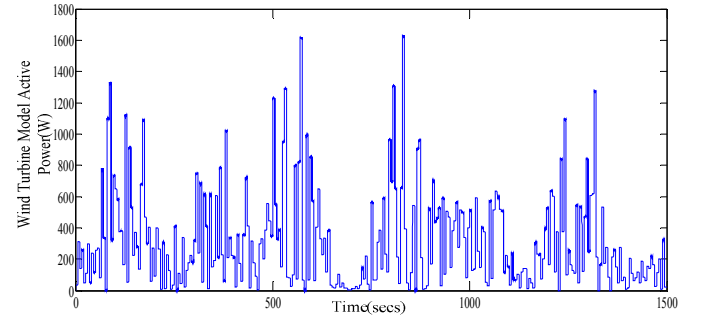

Fig. 11. Modeled active power output of the wind turbine

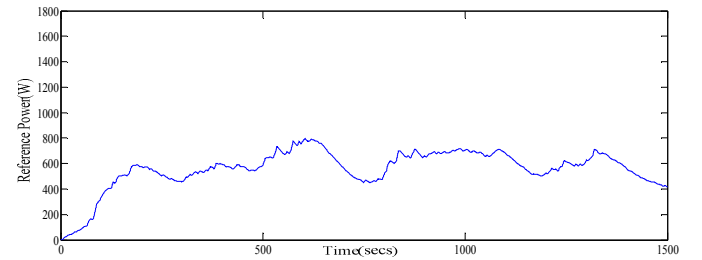

Fig. 12. Reference power obtained from the low pass filter.

Fig. 13 shows an expanded timescale of wind turbine output power for a 100 sec time interval. The expanded conditioner output is shown in Fig. 14. When the active wind power is less than the reference value, the conditioner injects active power into the line. When the active wind power is greater than the reference value, the conditioner draws power from the line. The resulting smoothed power is shown in Fig. 15. The smoothed power of the wind turbine is clearly following the reference signal. The voltage of the

ultracapacitor is shown in Fig. 16 and the voltage of the DC link is shown in Fig.17. Note that the ultracapacitor does not discharge significantly over the 100 sec time interval.

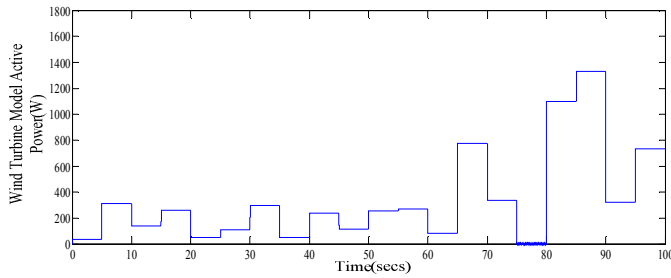

Fig. 13. Active power output of the wind turbine model

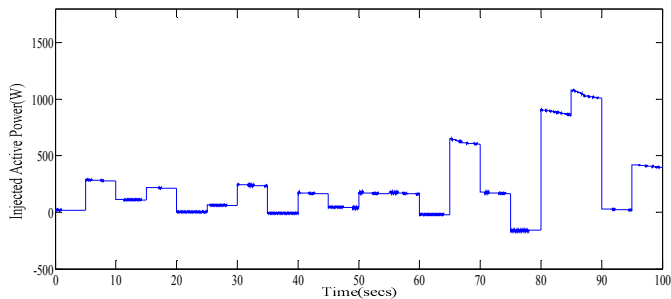

Fig. 14. Conditioner active power

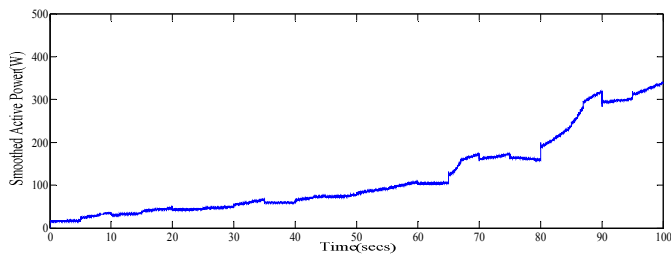

Fig. 15. Smoothed power at the grid interconnection point

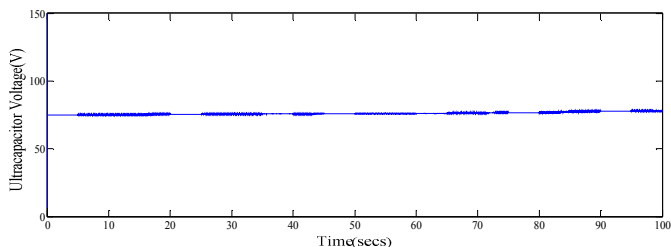

Fig. 16. Voltage of the ultracapacitor

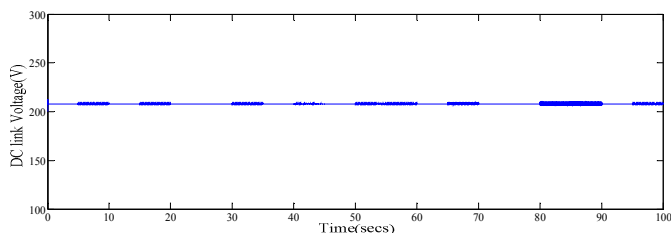

Fig. 17. Voltage of the DC link

VIII. CONCLUSION AND FUTURE WORK

In this paper, the design of a power conditioner and control for smoothing the wind turbine output power with the ultracapacitor is presented. The simulation results show that the proposed conditioner has a good performance in smoothing the wind power. The DC-DC converter maintains the voltage of the DC link relatively constant providing the good controllability of the shunt inverter. In the future, the hardware of the conditioner will be constructed and implemented. The conditioner and its control will be validated by connecting to a wind turbine installed at the Missouri University of Science and Technology.

IX. ACKNOWLEDGEMENT

The authors gratefully acknowledge the support of the DOE Energy Storage Program through Sandia National Laboratories under BD-0071-D. Sandia is a multi-program laboratory operated by Sandia Corporation, a Lockheed Martin Company, for the United States Department of Energy's National Nuclear Security Administration, under contract DEAC04-94AL85000

X. REFERENCES

- [1] P.F. Ribeiro, B.K. Johnson, M.L. Crow, A. Arsoy, and Y. Liu, "Energy Storage Systems for Advanced Power Applications," *Proceedings of the IEEE*, vol.89, no.12, pp.1744-1756, Dec. 2001.
- [2] Ming-Shun Lu, Chung-Liang Chang, Wei-Jen Lee, and Li Wang, "Combining the Wind Power Generation System With Energy Storage Equipment," *IEEE Trans. Industry Appl.*, vol.45, no.6, Nov-Dec. 2009.
- [3] Chih-Chiang Hua and Chia-Cheng Tu, "Design and implementation of power converters for wind generator," in *IEEE Industrial Electronics and Applications Conf.*, pp.3372-3377, May 2009.
- [4] M.S.A. Dahidah, N. Mariun, S. Mahmud and N. Khan, "Single phase active power filter for harmonic mitigation in distribution power lines," in *Proc. 2003 IEEE Power Engineering Conf.*, pp. 359- 362.
- [5] Yuanjie Rong, Chunwen Li, Honghai Tang, and Xuesheng Zheng, "Output Feedback Control of Single-Phase UPQC Based on a Novel Model," *IEEE Trans. Power Delivery*, vol.24, no.3, July. 2009.
- [6] H. Fujita, and H. Akagi, "The unified power quality conditioner: the integration of series and shunt-active filters," *IEEE Trans. Power Electronics*, vol.13, no.2, pp.315-322, Mar. 1998.
- [7] A. Kazemi, M. Sarlak, M. Barkhordary, "An Adaptive Noise Canceling Method for Single-Phase Unified Power Quality Conditioner," *IEEE Industrial Electronics and Applications Conf.*, May 2006.
- [8] Woonki Na and Bei Gou, "Analysis and control of bidirectional DC/DC converter for PEM fuel cell applications," in *IEEE Power and Energy Society General Meeting*, July 2008.
- [9] Lisheng Shi and M. L. Crow, "Comparison of ultracapacitor electric circuit models," in *IEEE PES General Meeting – July 2008*.
- [10] Bo Chen, Yimin Gao, M. Ehsani and J.M. Miller, "Design and control of a ultracapacitor boosted hybrid fuel cell vehicle," in *Proc. 2009 IEEE Vehicle Power and Propulsion Conf.*, pp.696-703.
- [11] A.S. Samosir and A. Yatim, "Dynamic evolution control of bidirectional DC-DC converter for interfacing ultracapacitor energy storage to Fuel Cell Electric Vehicle system," *Power Engineering Conf.*, Dec. 2008.
- [12] R. W. Erickson, and D. Maksimovic, "Fundamentals of power electronics," 2nd ed., New York: Kluwer Academic Publishers, 2000.
- [13] P. T. Krien, "Elements of power electronics," New York: Oxford University Press, 1998.
- [14] H. Akagi, "New trends in active filters for power conditioning," *IEEE Trans. Industry Applications*, vol.32, no.6, Nov/Dec. 1996.
- [15] T. Kai and A. Tanaka, "A new smooth scheme for power fluctuation using inverter of wind power generation with doubly fed induction generator," in *IEEE Electrical Machines and Systems International Conf.*, pp.2390-2395, Oct. 2008.