



Missouri University of Science and Technology
Scholars' Mine

Electrical and Computer Engineering Faculty
Research & Creative Works

Electrical and Computer Engineering

01 Sep 2008

Control Strategy Optimization for a Parallel Hybrid Electric Vehicle

Andrew Meintz

Mehdi Ferdowsi

Missouri University of Science and Technology, ferdowsi@mst.edu

Follow this and additional works at: https://scholarsmine.mst.edu/ele_comeng_facwork

 Part of the [Electrical and Computer Engineering Commons](#)

Recommended Citation

A. Meintz and M. Ferdowsi, "Control Strategy Optimization for a Parallel Hybrid Electric Vehicle," *Proceedings of the IEEE Vehicle Power and Propulsion Conference (2008, Harbin, China)*, Institute of Electrical and Electronics Engineers (IEEE), Sep 2008.

The definitive version is available at <https://doi.org/10.1109/VPPC.2008.4677505>

This Article - Conference proceedings is brought to you for free and open access by Scholars' Mine. It has been accepted for inclusion in Electrical and Computer Engineering Faculty Research & Creative Works by an authorized administrator of Scholars' Mine. This work is protected by U. S. Copyright Law. Unauthorized use including reproduction for redistribution requires the permission of the copyright holder. For more information, please contact scholarsmine@mst.edu.

Control Strategy Optimization for a Parallel Hybrid Electric Vehicle

Andrew Meintz and Mehdi Ferdowsi, *Member, IEEE*

Missouri University of Science and Technology, Rolla, MO, USA

Email: almdkc@mst.edu and ferdowsi@mst.edu

Abstract—The efficiency improvement of parallel hybrid electric vehicles (HEVs) is strongly dependent on how the supervisory control of a vehicle determines the power split between the internal combustion engine (ICE) and the electric motor of the vehicle. This paper presents a classification of current supervisory control techniques with distinction between dynamic and static control methods; a description of the simulation software **ADvanced Vehicle SimulatOR (ADVISOR)** with **Matlab Simulink** for simulation of a rule-based control strategy, and proposed optimization methods.

Keywords—ADVISOR; Control classification; Route prediction; Rule-based control; Supervisory control

I. INTRODUCTION

With the current increase in petroleum costs and the probability of more stringent air standards on the horizon; Hybrid Electric Vehicles (HEVs) have gained a greater acceptance as an alternative to a strictly internal combustion engine (ICE) vehicle. Current ICE vehicle technology can on average only use about 12-20% of the total energy fed to ICE for useful work at the wheels [1]. The incorporation of hybrid electric vehicle technology can be used to increase the overall efficiency of the ICE vehicle.

An increase in vehicle efficiency can be realized through the operation of the ICE in its optimal conversion regions and the ability to recover energy through regenerative braking. The ability to control the operating point of the ICE is achieved through the use of an electric motor to supplement or decrement the torque from the ICE to produce the required torque for vehicular operation. Regenerative braking is realized through the use of the tractive (or main) electric machine with a negative torque. Considering these two techniques for efficiency improvement, it is clear to see that the ability to optimally control the energy flow between the ICE and the electric machine will greatly affect the overall efficiency.

This paper will classify energy flow control topologies in section II. It will then consider a basic rule-based control framework in section III that will be expanded upon with a description of the ADVISOR model in section IV. Section V will contain proposed improvements to the rule-based control.

II. CONTROL CLASSIFICATIONS

There are currently a considerable number of optimization strategies for energy management systems. These strategies can be classified into three categories

global, static real-time, and dynamic real-time optimization.

Global optimization of an energy management system is a scheme in which a priori information is known about the entire drive cycle of the vehicle. These methods may consider the state of energy (SOE), state of charge (SOC), driving situation, route predictions on future demands, and driver responses. These methods are very difficult to implement in practice since they are computationally intensive and require information about future drive cycles. These may include fuzzy logic methods as in [2], genetic algorithms as in [3], or dynamic optimal control as in [1].

Static real-time optimization of an energy management system is a scheme in which the information on the instantaneous torque requirement, SOC, engine efficiency maps, and power system efficiency information are used to determine the most efficient power split. In the static systems this information is used against predefined rules to give a control output. These systems include the rule-based systems as in [4] and [5].

In the dynamic real-time optimization of an energy management system the instantaneous torque requirement, SOC, engine efficiency maps, and power system information are used with control values that can adapt to determine the controlled response. These systems can change certain rules based on a drivers' aggressiveness or the battery response to create a more optimal control solution. These systems include adaptive fuzzy [6] and adaptive equivalent fuel consumption minimization strategy (AECMS) [7].

III. A RULE-BASED FRAMEWORK

The rule-based control design is a very basic control strategy that relies on several modes or states of operation: engine only propelling, motor only propelling, charging hybrid-propelling, discharging hybrid-propelling, hybrid braking, and regenerative only braking. The strategy does not rely on feedback from individual controllers for the ICE, motor, and friction braking. The decision to change between modes is based on the power requirement of the acceleration or deceleration; the total power available from the ICE, motor, and friction brakes for acceleration or deceleration; the state of charge of the energy storage unit; and the speed of the vehicle [4]. A diagram of this system can be represented as in Fig. 1.

A. Operation Modes

1) Motor/ Engine Only Modes

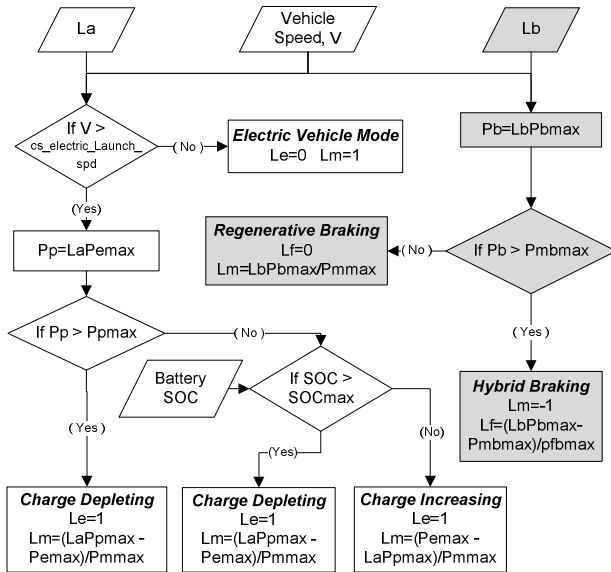

Figure 1. Functional diagram of rule-based system

The vehicle operates in motor only mode when the vehicle speed is below V_{eb} , in this mode all power is derived from the motor. The vehicle operates in engine only mode when the required propelling power is less than or equal to the max engine power ($P_p \leq P_{emax}$) and the state of charge is greater than or equal to the max state of charge ($SOC \geq SOC_{max}$).

2) Hybrid Braking Modes

The braking modes are all regenerative, regenerative and friction, and all friction braking. The control is based on the required braking power (P_b) and the total regenerative braking power (P_{mbmax}). Note that P_{mbmax} is relative to current vehicle speed and is not constant. The control strategy uses as much regenerative braking as possible using the friction brakes as a supplement. Interestingly the control does not consider the SOC of the energy storage system when making this decision.

3) Hybrid Propelling Modes

The hybrid propelling modes are charging and discharging modes. If $P_p > P_{pmax}$ then the system is operating in a discharging mode to give increased power to the drive train. If $P_p < P_{pmax}$ and the $SOC \leq SOC_{max}$ then the vehicle is operating in charging mode. In charging mode the excess energy from the ICE is used to charge the battery.

B. Improvement Considerations

This is a very basic method for controlling a parallel hybrid vehicle and is not a very effective optimization method. The determination of the set-point values for an optimal system would need to be included to improve the efficiency of this method.

1) ICE Operation Point

When in hybrid mode the system uses the ICE at one operating point using the motor as a generator or a motor to supplement or to decrement the propulsion power. This is probably not the most efficient method since it results in a high charge/discharge rate of the batteries. If the motor were operated at differing ideal efficiency points this charge/discharge rate could be reduced.

2) Electric-only Mode

The decision to go from electric only mode is based solely on the speed of the vehicle and does not take into account high torque / low speed situations where the motor may not be able to provide the required amount of power

3) SOC Maintenance

The control system does not set a SOC min level in which the system should switch from the discharging-hybrid mode to either the hybrid-charging mode or ICE only mode.

IV. SIMULATION USING THE ADVISOR MODEL

The ADVanced VehICle SimulatOR (ADVISOR) program uses Matlab Simulink to create a model of a hybrid electric vehicle. The control system for the parallel hybrid model is a rule based design. The rules are based on the required torque needed to propel the vehicle, the torque to speed efficiency map of the ICE, and the SOC of the energy storage unit. The system is designed to maximize the use of the ICE within its optimal torque / speed regions while balancing the energy use of the ESU.

The torque balancing of the ICE for this control system is based off of the torque/ speed efficiency map (see Fig. 2). The system tries to maintain the ICE within a percentage boundary of the maximum torque for the ICE at the operating speed as illustrated by Fig. 3. This boundary is defined by the constants $cs_lo_trq_frac$ and $cs_hi_trq_frac$ which are typically 90 and 60 percent of the maximum torque for a given speed. The system makes decisions based on the distance the required torque is from the mean torque value for a given speed.

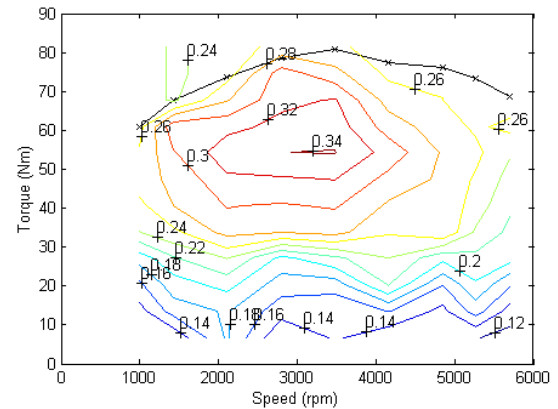

Figure 2. Typical efficiency map of an ICE operation modes

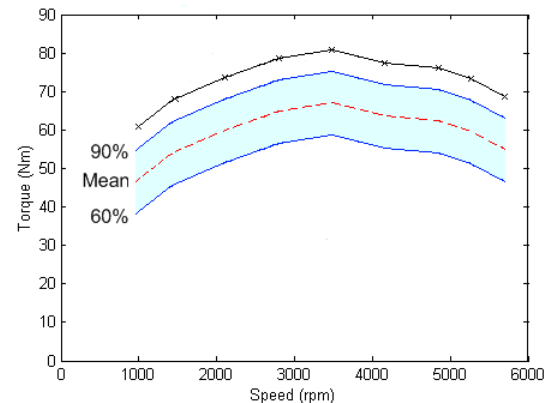

Figure 3. Typical efficiency map of an ICE

This decision is weighted by the torque correction factor (trq_frac) shown in Fig. 4. This factor puts a heavier weight on torque values closer to the mean torque (TRQ_mean) value as depicted by its plot (the dotted red line) in Fig. 3. The charge balancing of the energy storage unit (ESU) for this control system is based on the current SOC and the SOC correction factor. The system tries to maintain the SOC of the ESU within an acceptable charge boundary. This boundary is defined by the constants cs_lo_SOC and cs_hi_SOC which are typically 60 and 70 percent of the maximum charge of the ESU. The decision to charge or discharge the ESU is based on the SOC correction factor (SOC_frac) which puts a heavier weight on maintaining SOC values closer to the mean SOC value. The SOC_frac is depicted by its plot in Fig. 5.

A. Operation Modes

The general principles of charge and torque balancing of the vehicle are implemented into the overall control system through four different basic control modes, Electric Vehicle, Engine Only, Hybrid Charge Depleting, and Hybrid Charge Increasing. These modes are used to maintain an average constant charge in the ESU over many drive cycles in what is known as a charge sustaining operation. The specific decisions to switch between these modes are shown in the block diagram in Fig. 6.

1) Electric Vehicle (EV) Mode

This vehicle system is in EV mode when the ICE is allowed to idle ($vc_idle_bool = 0$) AND [The required TRQ is positive (not in REGEN braking) AND the required speed is less than cs_elec_decel OR when the speed is less than vc_idle_spd the system is in EV mode]

The vehicle is in EV mode when the required speed is less than cs_launch_spd AND the SOC is greater than the lower bound of the range for the desired SOC (cs_lo_soc) OR when the SOC is greater than the high bound of the range for the desired SOC (cs_hi_soc).

Desired TRQ less than the maximum torques scaled by lower bound of the range for the desired SOC (cs_lo_soc) AND EPS is less than the lower bound of the range for the desired SOC (cs_lo_soc) AND the SOC is greater than the mean of the desired SOC range. Blue portions are removed from the system when charge depleting operation is desired. ($cs_charge_deplete_bool = 1$)

2) Engine Only Mode

This vehicle system is in engine only mode when the ESU does not need charging and the ICE is operating in the higher efficiency range OR when the ICE torque exceeds the maximum but the ESU is too depleted for Hybrid Depletion or Electric Vehicle Mode..

3) Hybrid Charge Depleting

The vehicle is in hybrid depleting when ESU charge is sufficient and the motor is needed to supplement the ICE torque in order to put the ICE in a more efficient operation point

4) Hybrid Charge Increasing

The vehicle is in hybrid charging when the ESU needs charging and the motor is not needed to supplement the ICE torque to put the ICE in a more efficient operation point.

B. Torque Correction

When the system is in hybrid charge depleting or charge increasing mode the control system must determine

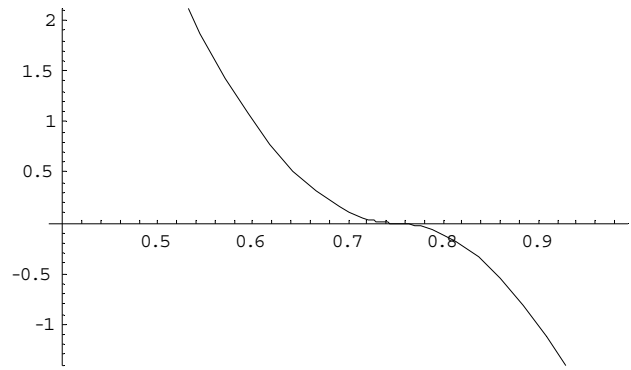

Figure 4. Torque correction factor

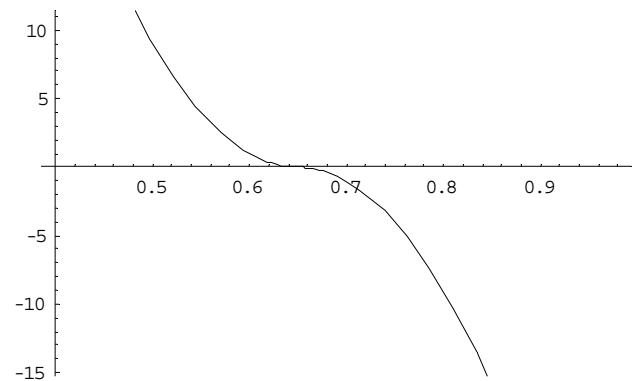

Figure 5. SOC correction factor

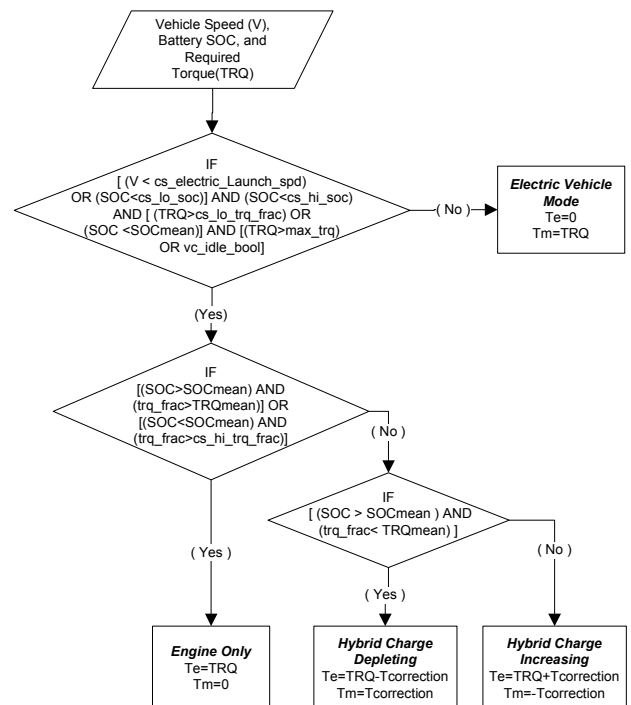

Figure 6. Functional diagram of the ADVISOR model proposed improvement methods

how much torque the motor will either supply or collect respectively. This value determination has been illustrated through the block diagram in Fig. 7.

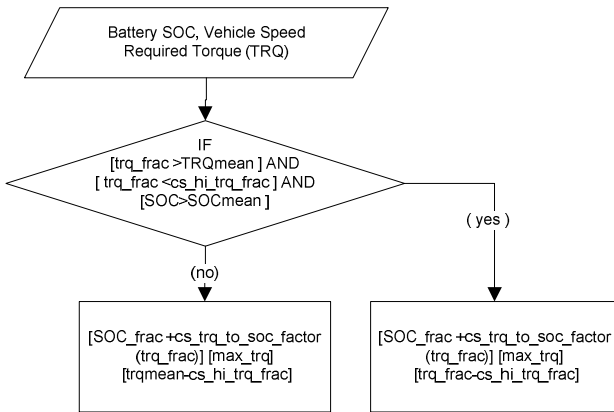

Figure 7. Calculation of the torque correction factor

V. PROPOSED IMPROVEMENT METHODS

A. Parameter Optimization Approach

A static method of optimizing the energy management system can be performed by using genetic algorithms and Dividing RECTangles (DIRECT) optimization on the control variables of the rule-based system. This method allows for a calculation of the global optimum of the control strategy for an experimental drive cycle; however, this inherently implies that the validity of the optimization is directly related to how similar the experimental drive cycle is to the actual drive cycle. This method does however present a simple implementation that involves very small calculations times which will yield a very responsive control system [8].

Simulation of this control strategy can be accomplished by completing the DIRECT optimization as outlined in [8] on the UDDS drive cycle to determine the optimal control values for the “fixed” parameters listed in Table I. This optimization strategy is to serve as an optimal solution for current rule-based strategies. This will give a baseline for use in the comparison of the following two methods.

B. A Rule-Based Equivalent Consumption Approach

This dynamic rule-based system utilizes an Equivalent Consumption Management Strategy (ECMS) to provide an optimal energy solution. The strategy works by determining the storage efficiency or the fuel to electric energy and the electric to motor efficiencies of the system. From this information a weighting factor is used to determine the cost and potential future savings of the use of increased ICE energy transformation. Basically the system tries to determine if at a current demand whether it should use the ICE at that demand or at an increased or decreased load (i.e. hybrid-charging or hybrid-discharging) based on the “cost” of the energy [7, 9].

The ECMS optimization would dynamically control the cs_hi_soc , cs_lo_soc , $cs_hi_trq_frac$, and $cs_lo_trq_frac$ parameters. The adaptation of this system is constituted by the predictor and adaptor models (see Fig. 8). The predictor uses GPS data and torque requests to determine the future state of the vehicle for a few time steps. The adaptor then uses this data to adjust the control parameters.

C. Route-Based Approach

An adaptive real-time method for optimizing the energy management in which GPS data is used to predict a short

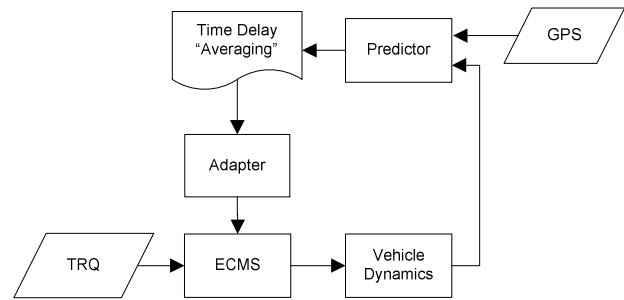

Figure 8. Functional diagram of the ECMS modification

term future route as proposed in [10]. This system would use a the DIRECT optimization method in [7] to optimize the control variables and fuzzy logic rules to select between sets of the optimized control variables based on the time of day, day of the week, and possibly the amount of SOC for charge-depleting hybrid configurations. These control variables would affect the length and number of hybrid charging and discharging cycles in the overall drive cycle. The future route prediction would be based off of the system proposed in [11].

The route-based optimization is based on dynamically controlling the cs_hi_soc , cs_lo_soc , $cs_hi_trq_frac$, and $cs_lo_trq_frac$ parameters based on previously calculated optimal set points for the current segment of the route and the predicted future segments (see Fig. 9). If the vehicle happens to be on a new segment of road the vehicle will default to standard set points for the parameters and collect vehicle speed, required torque, and efficiency data. The optimal set points for each new segment will then be determined when the vehicle has completed the segment a specific number of times (cs_seg_cnt) and the vehicle’s processor has been idle for a given amount of time (cs_prces_idle). The determination of optimal parameter values could be based on the DIRECT optimization method in [7].

The route prediction of the vehicle will combine the commonly used segments into routes. The segments will be defined as the largest possible continuous section of a route which does not contain a previously made turn. Note that even if there happens to be multiple roads that intersect a route a new segment will only be defined if the vehicle has previously made a turn onto that road. The routes are divided into segments so that if the vehicle does not use a specific route an efficient solution can be obtained by stitching together the smaller segments of other routes. Routes may be divided into smaller pieces if the route length exceeds the maximum route length setting (cs_route_max).

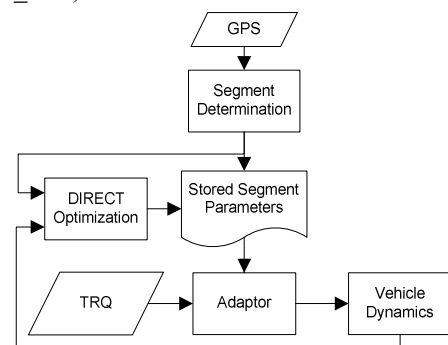

Figure 9. Functional Diagram of the Route Based Modification

Route and segment control will also differentiate between optimization information based on the time of day and day of the week (weekday or weekend) as traffic conditions and speeds will vary. This differentiation could be implemented through a fuzzy logic method to limit the knowledge base. The inconsistencies imposed by different drivers will be reduced by separating the optimization and route data based for each driver. This will help to properly adjust the prediction of differing routes and the effects of a driver's aggressiveness on the required torque.

VI. CONCLUSION

The supervisory control of a parallel hybrid presents the challenge of making optimization decisions that are heavily dependent on future action. Since driving patterns tend to repetitious, systems that incorporate learning of past actions to predict the future should result in more optimal solutions. The result of these systems ability to predict the future state and work from predefined optimal settings should result in a fair approximation of a globally optimal solution in real time. The simulation of these proposed improvement methods will be left for a future paper.

REFERENCES

- [1] M. Salman, M.F. Chang, J.S. Chen, "Predictive energy management strategies for hybrid electric vehicles", in Proc. IEEE Vehicle Power and Propulsion Conference, Chicago, IL, Sept. 2005, pp 536-540
- [2] J.S. Won and R. Langari, "Intelligent energy management agent for a parallel hybrid vehicle-part II: torque distribution, charge sustenance strategies, and performance results," IEEE Trans. on Vehicular Technology, vol.54, no.3, pp. 935-953, May 2005
- [3] A. Piccolo, L. Ippolito, V. Z. Galdi, and A. Vaccaro, "Optimisation of energy flow management in hybrid electric vehicles via genetic algorithms," Proc. IEEE/ASME Advanced Intelligent Mechatronic Conf., July 2001, Como, Italy, pp.434-439
- [4] C. Liang, W. Qingnian, L. Youde, M. Zhimin, Z. Ziliang, and L. Di, "Study of the electronic control strategy for the power train of hybrid electric vehicle," Proc. IEEE Vehicle Electronics Conf., Sept 1999, Changchun, China, pp.383-386.
- [5] Y. Cheng, S. Cui, L. Song, and C. C. Chan, "The study of the operation modes and control strategies of an advanced electromechanical converter for automobiles," IEEE Transactions Magnetics, vol.43, no.1, pp.430-433, Jan. 2007
- [6] F.U. Syed, Y. Hao, Ming Kuang; Okubo, S.; Smith, M., "Rule-based fuzzy gain-scheduling PI controller to improve engine speed and power behavior in a power-split hybrid electric vehicle," Proc. NAFIPS Fuzzy Information Processing Society, 3-6 June 2006, Montreal, pp.284-289.
- [7] P. Pisu and G. Rizzoni, "A comparative study of supervisory control strategies for hybrid electric vehicles," IEEE Trans. Control Systems Technology, vol.15, no.3, pp.506-518, May 2007.
- [8] B. Huang, X. Shi, and Y. Xu, "Parameter optimization of power control strategy for series hybrid electric vehicle," Proc. IEEE Congress on Evolutionary Computation, 16-21 July 2006, Vancouver, pp. 1989-1994.
- [9] T. Hofman and M. Steinbuch, "Rule-based energy management strategies for hybrid vehicles," Int. J. Electric and Hybrid Vehicles, vol. 1, no. 1, pp 71-94, 2007.
- [10] M.H. Hajimiri, and F.R. Salmasi, "A fuzzy energy management strategy for series hybrid electric vehicle with predictive control and durability extension of the battery," Proc. IEEE Electric and Hybrid Vehicles, Conf., 18-20 Dec. 2006, Maharastra India, pp.1-5.

TABLE I
PARAMETERS IN SIMULINK MODEL

Parameter	Description	Standard Value	Type
cs_hi_soc	highest state of charge	0.7	fixed
cs_lo_soc	highest state of charge	0.6	fixed
cs_hi_trq_frac	highest desired engine load fraction	0.9	fixed
cs_lo_trq_frac	lowest desired engine load fraction	0.6	fixed
cs_trq_to_soc_factor	weighting factor for the relative importance of engine operation near the goal to the SOC operation near the goal ==> low values mean that SOC is more important, large values mean engine is more important	0.13	fixed
vc_idle_spd	idle speed of the engine	0	fixed
vc_launch_spd	clutch input speed during clutch slip at vehicle launch	99.4833	fixed
cs_charge_deplete_bool	1=> use charge deplete strategy, 0=> use charge sustaining strategy	0	fixed
cs_charge_trq	hybrid_chargetrq*(SOCinit-SOC) = an alternator-like torque loading on the engine to recharge the battery pack; negative recharge is never requested	15.25	fixed
vc_idle_bool	1 = engine idles, 0= engine turns off when it would otherwise idle	0	fixed
TRQmean	calculated value of the mean value of cs_hi_trq_frac and cs_lo_trq_frac		fixed
SOCmean	calculated value of the mean value of cs_hi_trq_frac and cs_lo_trq_frac		fixed
trq_frac	calculated value of the weighted difference the required torque is from TRQmean		varying
soc_frac	calculated value of the weighted difference the required SOC is from SOCmean		varying
TRQ	the required torque for the vehicle		varying
max_trq	the maximum torque that the ICE can provide at the given speed		varying
cs_seg_cnt	number of data sets that must be collected before a segment's optimized parameters can be determined		fixed
cs_route_max	the maximum length of a route		fixed
cs_prces_idle	amount of time the processor must be idle before optimization processing can be performed		fixed

- [11] Simmons, R.; Browning, B.; Yilu Zhang; Sadekar, V., "Learning to predict driver route and destination intent," Proc. IEEE Intelligent Transportation Systems Conf., Oct. 2006, Toronto, pp.127-132.