



Missouri University of Science and Technology
Scholars' Mine

Electrical and Computer Engineering Faculty
Research & Creative Works

Electrical and Computer Engineering

01 Aug 2008

Advanced Full Wave ESD Generator Model for System Level Coupling Simulation

Qing Cai

Argha Nandy

David Pommerenke

Missouri University of Science and Technology, davidjp@mst.edu

Jong-Sung Lee

et. al. For a complete list of authors, see https://scholarsmine.mst.edu/ele_comeng_facwork/742

Follow this and additional works at: https://scholarsmine.mst.edu/ele_comeng_facwork

 Part of the [Electrical and Computer Engineering Commons](#)

Recommended Citation

Q. Cai et al., "Advanced Full Wave ESD Generator Model for System Level Coupling Simulation," *Proceedings of the 2005 International Symposium on Electromagnetic Compatibility, 2008. EMC 2008*, Institute of Electrical and Electronics Engineers (IEEE), Aug 2008.

The definitive version is available at <https://doi.org/10.1109/ISEMC.2008.4652137>

This Article - Conference proceedings is brought to you for free and open access by Scholars' Mine. It has been accepted for inclusion in Electrical and Computer Engineering Faculty Research & Creative Works by an authorized administrator of Scholars' Mine. This work is protected by U. S. Copyright Law. Unauthorized use including reproduction for redistribution requires the permission of the copyright holder. For more information, please contact scholarsmine@mst.edu.

Advanced full wave ESD generator model for system level coupling simulation

Cai Qing, Jayong Koo, Argha Nandy,
and David Pommerenke
Electrical and Computer Engineering
Missouri University of Science and Technology
Rolla, MO, U.S.A.
davidjp@mst.edu

Jong Sung Lee and Byong Su Seol
Manufacturing Technology R&D Center
Samsung Electronics
Suwon, Korea

Abstract— System level ESD tests can only be performed after hardware is available. Simulating the ESD coupling into a circuit allows at least parametric and quantitative studies of the expected ESD behavior. A complete simulation requires us to model the ESD generator, the passive elements of the DUT and the response of the ICs to injected noise. Having the ultimate objective of combining IC soft error response models with the DUT structure and the ESD generator we report on progresses in modeling the ESD generator and its coupling. The model improves the useful frequency range from a few hundred MHz to about 3 GHz.

Keywords—Electrostatic discharge, Numerical modeling

I. INTRODUCTION

The prediction of ESD behavior is a complex problem. Its source modeling spans from low frequency charge distribution, over high voltage breakdown physics, to problems that can only be understood by antenna theory. The victim modeling usually requires modeling of passive structures, like cables, PCBs and, for the prediction of IC response some level of IC immunity models. IC immunity models are a topic of research and are in general not available. However, one can characterize modules of a system (e.g., an LCD) using direct injection of immunity scanning methods and obtain a sensitivity limit, expressed in injected currents or induced voltages for a module at an interface. Having such data available, the need for detailed, e.g., 8-layer PCB modeling of a module maybe reduced, such that it is possible to model a complex system as a system of cable connected blocks. This simplifies the simulation of the system.

Besides the system, the ESD generator needs to be simulated. A variety approaches are possible, most simply using forced injected currents as provided in the ESD standard [1], over equivalent circuit models [2] to full wave models [2]-[5]. Only the full wave models are able to predict the field coupling. The

field coupling is essential, especially for soft-error prediction, as they are often caused by the frequency components of ESD transient fields greater than 1 GHz.

A variety of full wave models have been published for ESD prediction. As a result of cooperation with the authors of this article [4] a model has been published, that is suitable to operate on standard electromagnetic software such as CST Microwave studio and that also has been ported to FlowEMC (Microstrips). This model emulates the structure of the ESD generator coarsely and excites the structure with a step function having 1 ns rise time. Here it contrasts from real ESD generators in an important point: The voltage collapse in the high voltage relays, usually used, occurs in 50-100 ps. As the standard asks for 700 – 1000 ps rise time of the current at the discharge tip a low pass filter is present in every ESD generator. Thus, the injected current mainly contains frequency components below 300 MHz (it may also contain some higher frequencies if the current rise is not smooth). However, the fast voltage collapse in the relay excites the structure of the ESD generators. This causes radiation of strong ESD transient fields with frequency components greater than 1 GHz, often leading to soft errors. It needs to be noted that this is strongly affected by the detailed construction of each ESD generator model. Due to the fast voltage collapse, ESD generator models should model the relay and the associated low pass filters including its radiating structures with sufficient detail to predict the radiated fields accurately. Without correctly modeling the voltage collapse in the relay the results may not match the high frequency behavior. An example is show in Fig. 1. The simulated wave form is smooth relative to the measured wave form, thus the high frequency components that are present during testing have not been modeled with sufficient accuracy.

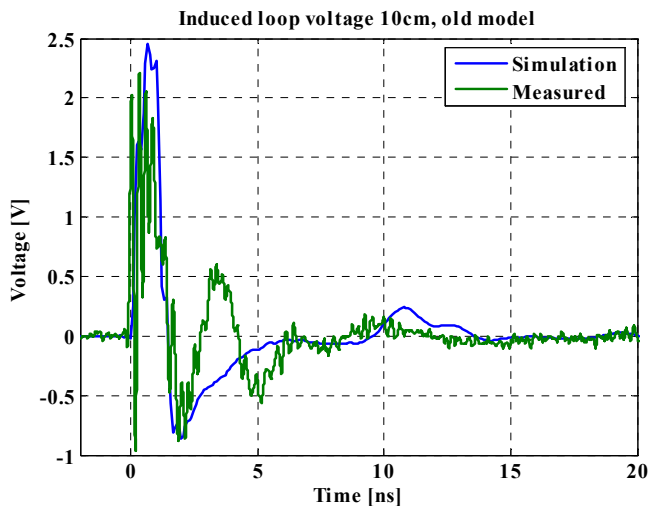

Fig. 1 Induced loop voltage of previous ESD generator model (Centola/Pommerenke/Caniggia) compared to measurements

A highly detailed approach has been published by K.Wang [2]. However, this was based on special FDTD codes from Zeland Software and a code developed by the MST EMC laboratory that allowed time varying material constants to emulate the breakdown within the relay.

To expand the usability of a detailed modeling approach, we created a detailed model, using more generally used software Microstripes This model includes the details of the relay and the low pass filter and has been verified by:

- Injected current
- Voltages induced in a loop close to the generator
- Currents on a cable attached to a small, hand held device
- Voltages induced within a small mobile device.

The paper explains the model, its results and discusses the limits.

II. NUMERICAL MODEL

Our objective is to create a full wave model that allows simulating the coupling into systems for frequencies up to at least 2 GHz, having calculation times of hours (not days). An overview of the model is shown in Fig. 2. An off-the-shelf ESD generator was used for the full wave model.

The model consists of the following major parts:

- **Voltage source.** As source, a step function has been used. Its rise-time is about 200 ps. It has been designed based on an integrated Gaussian pulse to ensure a smooth rising edge. Alternative approaches would base the rise on the functional behavior of the spark resistance inside the relay, e.g., as expressed by Rompe & Weizel's law. The shape and rise time of this pulse allows us to adopt the RF spectrum of the ESD generator to approximately accommodate other ESD generator models.
- **Low pass filter.** The relay connects to the other parts of the ESD generator via an R-C-R low pass filter. The

resistors are discrete carbon composition resistors, while the capacitor is made from RR-4 PCB. The R-C-R structure also forms a loop, such that its inductance improves the low pass filter function

- **Main RC elements.** The ESD standard asks for a 330 Ohm / 150 pF main time constant of the ESD generator. This is implemented as a combination of capacitors connected in series (due to the maximal voltage allowed for the capacitors) and a series connection of resistors.
- **Discharge tip.** The discharge tip is a metal extension.
- **Structural elements of the ESD generator and electronics.** The electronic circuit boards, display and battery pack are modeled as metallic blocks.
- **Ground strap.** Its main function is allowing the return of low frequency components of the current (charge return). However, in most ESD generators the ground strap is not decoupled for RF, from the pulse creating parts of the ESD generator. Thus, strong RF currents, e.g., created by the initial peak of the breakdown will flow on the ground strap. The ground strap is modeled as a metallic connection.
- **Additional details.** Additional details, such as the impedance looking into the high voltage supply have been measured and implemented in the model.

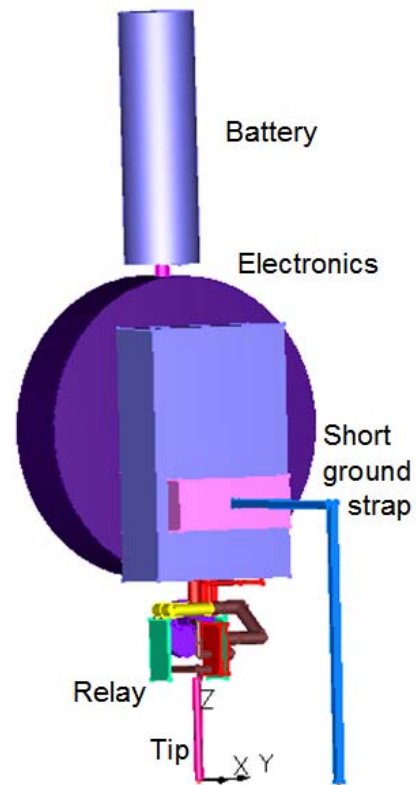

Fig. 2 ESD generator full wave model overview

Details of the pulse forming parts are shown in Fig. 3. The step function source is located within the relay.

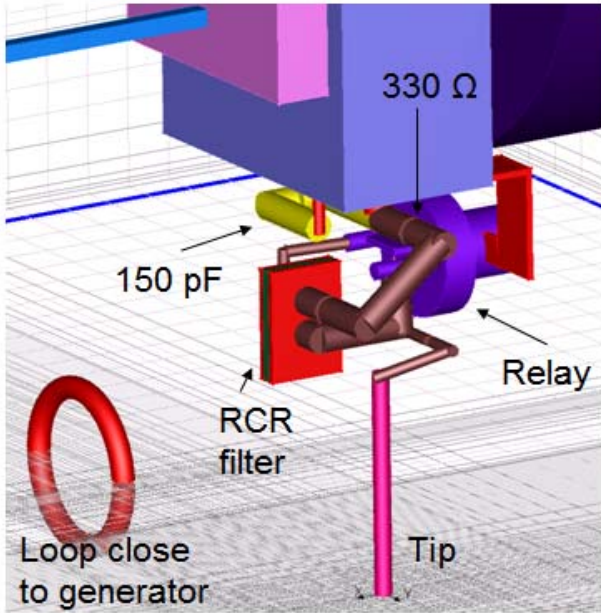

Fig. 3 Details of the pulse forming elements

III. VERIFICATION

The current injected into a large ground plane is a main criterion for ESD generator performance. The current has been measured using a ESD current target (> 4 GHz) and a 4 GHz, 20 GS/sec oscilloscope. The fast rising and possibly ringing behavior of the first peak in the discharge current waveform, dominates the disturbances in electronic system.

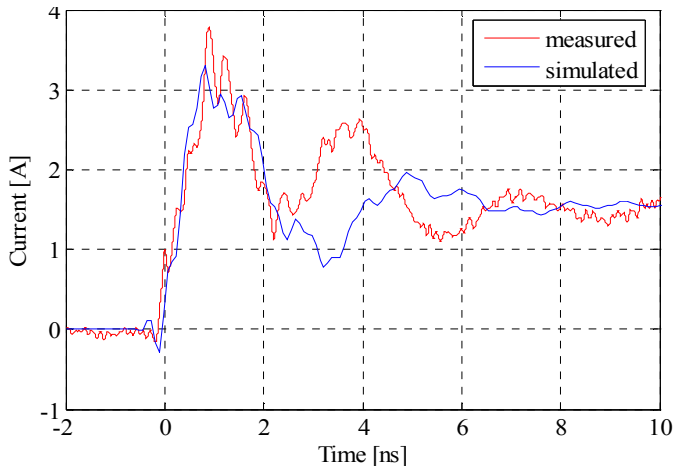

Fig. 4 Simulated and measured ESD discharge current, for the first 10 ns.

The data shown in Fig. 4 indicate a good match for the initial pulse. However, the ringing of the pulse is at present not well modeled. However from the point of view of induced noise, the initial pulse often dominates the DUT's response. Hence the deviation shown has been accepted for now.

A. Results: Voltage induced in a small loop

The ESD standard IEC 61000-4-2 is presently being revised to address the problems of ESD test result repeatability. One measure to better characterize an ESD generators is the voltage induced in a loop close to the ESD generator. To avoid possible coupling into cables a ground plane mounted semi-circular loop is used. It is unshielded, thus, it is sensitive to the E and the H field. Its diameter is 28 mm and it is placed at a distance of 10 cm from the point of discharge. Such a loop represents a wire loop within an electronic system and is a better predictor for system level disturbances than the discharge current. The standard will provide intended induced loop voltage waveforms such that the actual ESD generator manufacturers can compare their instruments against the optimal waveforms given by the standard.

We used the semi-circular loop to verify the simulation model of the ESD generator against measurements. The results are shown in Fig. 5.

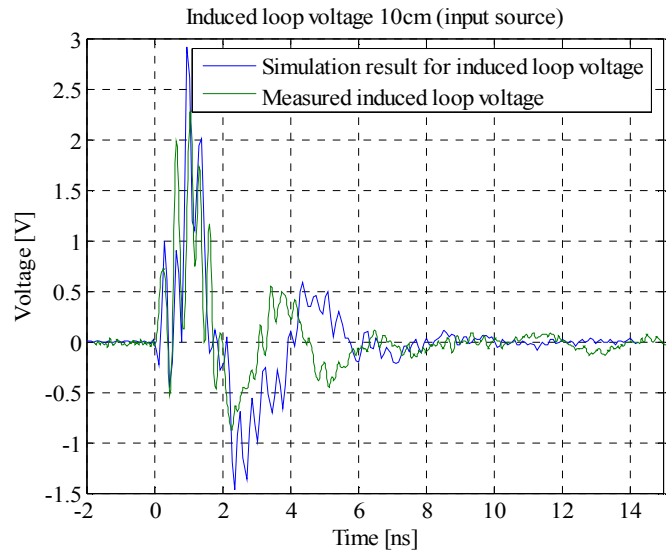

Fig. 5 Measured and simulated induced loop voltage

It is significantly more difficult to achieve a good match between the simulation and the measurement for an induced loop voltage relative to the injected current. The reason is the high pass behavior of the induced loop voltage and the field coupling. Thus, the generator model needs to be sufficiently accurate up to a few GHz. To better visualize the frequency range of validity a comparison of the spectra was performed:

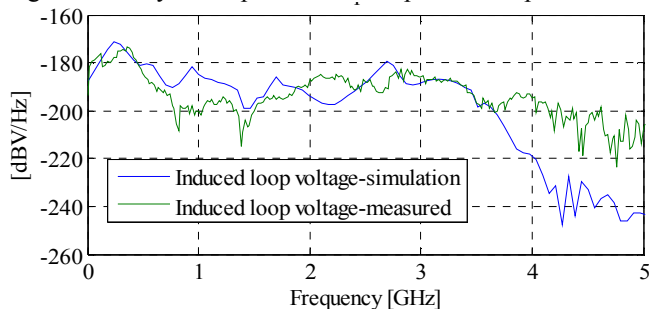

Fig. 6 Comparison of simulated and measured spectra of the induced loop voltage

The data shown in Fig. 6 indicate a usable frequency range of up to about 3 GHz. Greater precision modeling of the components around the relay structure could provide a better match of the simulated waveform to the measured data in the frequency range of 0.6 to 1.4 GHz.

IV. APPLICATIONS

A. Application #1: Current in a wire attached to a handheld device

If the device under test is small, e.g. a PDA, then any attached wires will change the currents on the device significantly. As a first step the current in a cable attached to such a device has been modeled. Due to the high density of components in the device and as no internal voltages are asked for (see next application for internal voltages), it is possible to model the device as a single metallic block. The wire has been suspended above the ground by a 2 cm thick dielectric (Styrofoam). Attempts to use a 0.5 mm thick dielectric, as required by the standard, led to numerical difficulties that could not be resolved in time for this draft manuscript. It is subject to intensive investigations. Fig. 7 shows the simulation model of the ESD generator with a small handheld device and a cable attached to it.

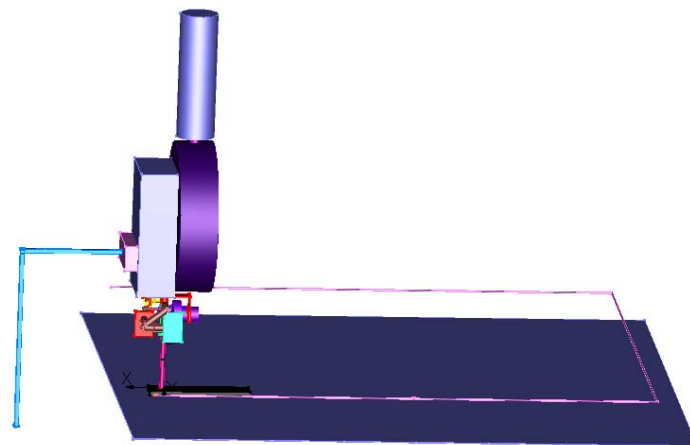

Fig. 7 Small handheld device having a cable attached

To reduce the domain size of the simulation model, a short ground strap was used. This changes the tail current of the ESD generator wave form, but experience shows that the tail current has little influence on disturbances.

The current was measured in the middle of the first segment using an F-2000 current probe and is compared to the simulation in Fig. 8. The frequency response of the current probe was compensated by de-convolving the measured time domain data.

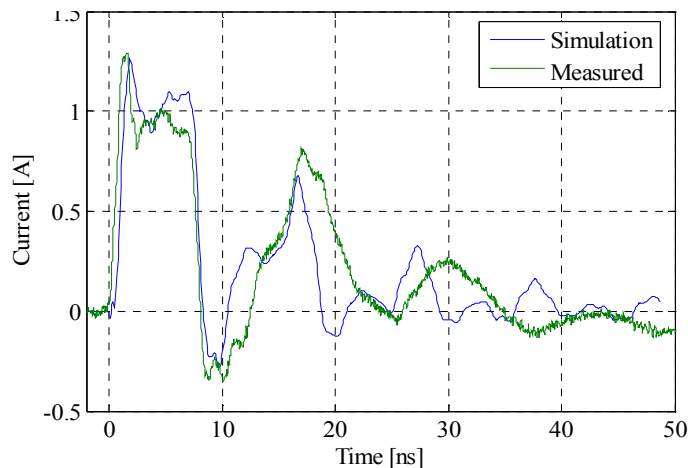

Fig. 8 Measured and simulated current in the attached cable

B. Application #2: Voltage within the hand held device

A significantly more difficult problem is the prediction of the current within a small device. This requires modeling the significant elements of the device. A further complication is posed by our desire to compare with measurement results. Measuring voltages inside a device, while performing ESD tests is a very challenging task. It requires very good suppression of any common mode currents and optimal shielding of the oscilloscope and all connecting cables. We decided to use the voltage between a part of the shield and the PCB as a test case. An off-the-shelf small hand held device was used for the measurements and full wave simulation.

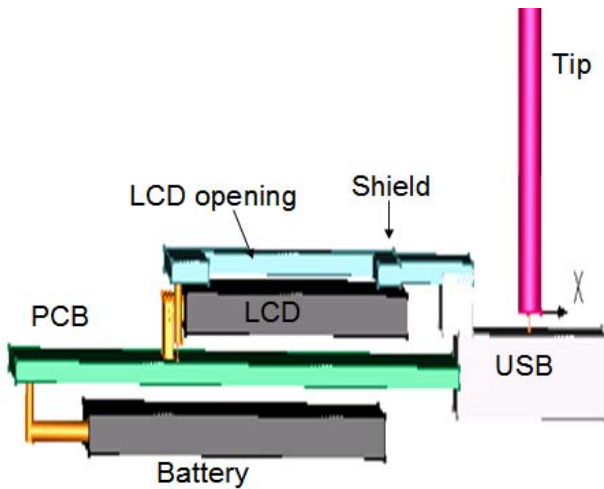

Fig. 9 Model of the handheld device structure

Fig. 9 shows the simulation model of the hand held device. The top plastic half of the hand held device contains a LCD opening and a metallic shield. It connects to the PCB only at the USB connector via a gasket. There is no connection of the shield on the left side, at which the LCD connects to the PCB. Thus, a relatively large voltage can be induced. This voltage would be partially coupling into the LCD connection wires making the measurement of this voltage a relevant target for verifying the ESD generator model. The metallic and lossy blocks were used for the full wave model shown in Fig. 9. The discrete blocks are: the battery, connecting cables, the main PCB, the LCD display, a shield and the USB connector. The shield forms a resonator, as it is only connected on the USB connector side. The voltage between the shield and the PCB has been selected as measurerand. A microscope view reveals the details of the coax cable connections in Fig. 10and Fig. 11.



Fig. 10 Side view of the hand held device showing the entry of the coax cable into the player

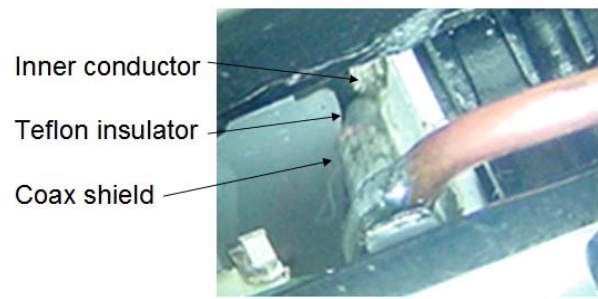

Fig. 11 Details of the coax cable connection

The outer conductor of the coax cable is attached to the PCB and the inner conductor is attached to the metal shield of the device. Fig. 12 shows the comparison of the simulated and measured induced voltage inside the hand held device.

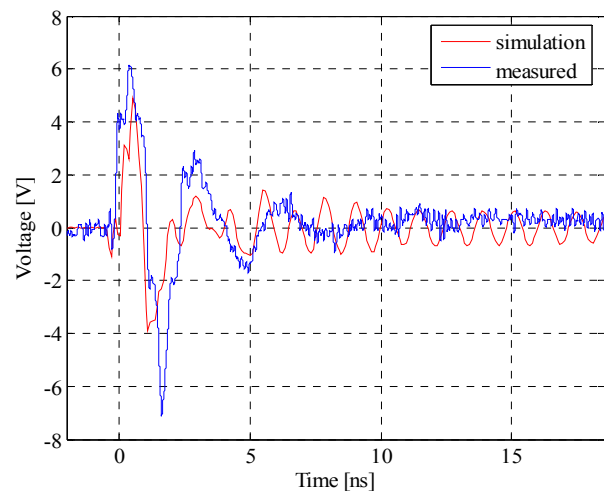

Fig. 12: Comparison of simulated and measured induced voltage

The measurement is able to predict the main noise pulses with moderate accuracy. Also a stronger ringing is visible in the simulation result. We believe that this ringing is suppressed in the measurement data by many ferrites that are placed on the outside of the coax cable used to probe the voltage. It is difficult to simulate the ferrites in a time domain analyzer, especially as they might saturate at the current levels injected by the ESD generator. However, one has to consider that this is a demanding test case.

V. LIMITS

We are researching methodology for predicting the ESD soft-error response of systems. This requires a combination of ESD generator model, correctly simplified DUT model and IC response model. The present paper has analyzed the ESD generator and coupling into the DUT. We see the following challenges:

- The ESD generator model yet does not match some of the fine structure of the discharge current pulse, especially the 300-800MHz ringing after the initial peak. This might not be of concern to the modeling accuracy.
- On comparing ESD generators from different manufacturers, different transient fields will be measured. Thus, the numerical model must model the specifics of the ESD generator used in system level testing.
- The falling edge of the current (e.g., at 30 ns) in the cable attached to the hand held device is not well modeled, since we substitute the ground strap in the actual measurement by either a short ground strap or a short ground strap and an inductor. Our primary objective to do this was to reduce the domain size. During testing, we did not observe any soft errors being caused by the tail current and hence do not consider this an important limitation.
- The modeling of the DUT may have to include finer details of the PCB, IC and bond wire structure. This will clearly lead to a very large computational problem. The selection of the correct simplifications will be based on experience in the analysis of ESD problems on previous products.
- The IC input response model is not included in the simulation yet. However, based on experience we can estimate if a current or voltage might cause a problem.

We consider the last two aspects to be the most difficult challenges on the path to a complete ESD soft error response simulation.

VI. CONCLUSIONS

An improved ESD generator model has been introduced. It's usefulness has been shown on simple and more demanding test cases: ESD current, voltage induced in a small loop, voltage induced inside a small product.

REFERENCES

- [1] 77B/378/CDV, "IEC 61000-4-2: EMC-Part 4-2: testing and measurement techniques- ESD immunity test", 2003-04-11.
- [2] H. Tanaka, O. Fujiwara, Y. Yamanaka, "A circuit approach to simulate discharge current injected in contact with an ESD-gun", *2002 3rd Int. Symp. Electromagnetic Compatibility*, pp. 486 – 489, 21-24 May 2002
- [3] K. Wang, D. Pommerenke, R. Chundru, T. Van Doren, J. Drewniak, A. Shashindranath, "Numerical Modeling of Electrostatic Discharge Generators", *IEEE Trans. on EMC*, vol.45, no.2, May 2003.
- [4] F. Centola, D. Pommerenke, K. Wang, T. V. Doren and S. Caniggia, "ESD excitation model for susceptibility study," *IEEE Int. Symp. Electromagnetic Compatibility*, vol.1, pp.58 – 63. 18-22 Aug. 2003
- [5] S. Caniggia, F. Maradei, "Circuit and Numerical Modeling of Electrostatic Discharge Generators", *Industry Applications Conference, 2005*, Vol. 2, pp. 1119-1123, Oct. 2005