



Missouri University of Science and Technology
Scholars' Mine

Electrical and Computer Engineering Faculty
Research & Creative Works

Electrical and Computer Engineering

01 Feb 2001

Dynamic Performance of a Static Synchronous Compensator with Energy Storage

Aysen Arsoy

Yilu Liu

Shen Chen

Zhiping Yang

et. al. For a complete list of authors, see https://scholarsmine.mst.edu/ele_comeng_facwork/1564

Follow this and additional works at: https://scholarsmine.mst.edu/ele_comeng_facwork

 Part of the [Electrical and Computer Engineering Commons](#)

Recommended Citation

A. Arsoy et al., "Dynamic Performance of a Static Synchronous Compensator with Energy Storage," *Proceedings of the IEEE Power Engineering Society Winter Meeting, 2001 (2001, Columbus, OH)*, vol. 2, pp. 605-610, Institute of Electrical and Electronics Engineers (IEEE), Feb 2001.

The definitive version is available at <https://doi.org/10.1109/PESW.2001.916918>

This Article - Conference proceedings is brought to you for free and open access by Scholars' Mine. It has been accepted for inclusion in Electrical and Computer Engineering Faculty Research & Creative Works by an authorized administrator of Scholars' Mine. This work is protected by U. S. Copyright Law. Unauthorized use including reproduction for redistribution requires the permission of the copyright holder. For more information, please contact scholarsmine@mst.edu.

Dynamic Performance of a Static Synchronous Compensator with Energy Storage

Aysen Arsoy, Yilu Liu
Dept. of Electrical and Computer Eng.
Virginia Tech
Blacksburg, VA 24061-0111
abasa@vt.edu, yilu@vt.edu

Shen Chen, Zhiping Yang, Mariesa. L. Crow
Dept. of Electrical and Computer Eng.
University of Missouri-Rolla
Rolla, MO 65409-6671
schen@ece.UMR.edu, crow@ece.UMR.edu

Paulo. F. Ribeiro
Engineering Department.
Calvin College
Grand Rapids, MI 49456
pribeiro@calvin.edu

Abstract: This paper discusses the integration of a static synchronous compensator (StatCom) with an energy storage system in damping power oscillations. The performance of the StatCom, a self-commutated solid-state voltage inverter, can be improved with the addition of energy storage. In this study, a 100 MJ SMES coil is connected to the voltage source inverter front-end of a StatCom via a dc-dc chopper. The dynamics of real and reactive power responses of the integrated system to system oscillations are studied using an electromagnetic transient program PSCADTM/EMTDCTM, and the findings are presented. The results show that, depending on the location of the StatCom-SMES combination, simultaneous modulation of real and reactive power can significantly improve the performance of the combined compensator. The paper also discusses some of the control aspects in the integrated system.

Keywords: Energy storage, StatCom, power system oscillations, SMES, dc-dc chopper.

I. INTRODUCTION

A static synchronous compensator (StatCom), is a second generation flexible ac transmission system controller based on a self-commutated solid-state voltage source inverter. It has been used with great success to provide reactive power/voltage control and transient stability enhancement [1-5]. StatCom controllers are currently utilized in two substations, (one at Sullivan substation of Tennessee Valley Authorization, TVA, and the other one is at Inez substation of American Electric Power, AEP) [4, 5]

A StatCom, however, can only absorb/inject reactive power, and consequently is limited in the degree of freedom and sustained action in which it can help the power grid. As expected and demonstrated in the past [6], modulation of real power can have a more significant influence on damping power swings than can reactive power alone [7]. Even without much energy storage, static compensators with the ability to control both reactive and real power can enhance the performance of a transmission grid. Thus, a StatCom with energy storage allows simultaneous real and reactive power injection/absorption, and therefore provides additional benefits and improvements in the system. The voltage source inverter front-end of a StatCom can be easily interconnected with an energy storage source such as a superconducting magnetic energy storage (SMES) coil via a dc-dc chopper.

SMES systems have received considerable attention for power utility applications due to its characteristics such as rapid response (mili-second), high power (multi-MW), high efficiency, and four-quadrant control. SMES systems can

provide improved system reliability, dynamic stability, enhanced power quality and area protection [8-15]. Among these applications, the ones with the power ranges of 20 – 200 MW and the energy ranges of 50 – 500 MJ are cost beneficial applications [15]. Advances in both superconducting technologies and the necessary power electronics interface have made SMES a viable technology that can offer flexible, reliable, and fast acting power compensation.

This work intends to model and simulate the dynamics of the integration of a ± 160 MVAR StatCom and a 100 MJ SMES coil (96 MW peak power and 24 kV dc interface) which has been designed for a utility application. In this paper, modeling and control schemes utilized for the StatCom-SMES are described first. Then, the impact of the combined compensator on dynamic system response is discussed. The effective locations of the compensator are compared for a generic power system.

II. MODELING AND CONTROL DESCRIPTION OF THE StatCom-SMES COMPENSATOR

A self-commutated solid state voltage source inverter connected to a transmission line acts as an alternating voltage source in phase with the line voltage, and, depending on the voltage produced by the inverter, an operation of inductive or capacitive mode can be achieved. This has been defined as a StatCom operation. The primary function of the StatCom is to control reactive power/voltage at the point of connection to the ac system [1-4]. A dc coupling capacitor exists to establish equilibrium between the instantaneous output and input power of the StatCom. The dc side of the StatCom can easily be connected to an energy storage source to provide simultaneous real and reactive power injection and/or absorption, and therefore to yield to a more improved, flexible controller.

To show the dynamic performance of a StatCom with energy storage, this study used a typical ac system equivalent as shown in Fig. 1. The energy storage source is a big inductor representing the SMES coil. A dc-dc chopper is also modeled to control the terminal voltage of the SMES coil in the integration of the StatCom into the coil. The detailed representation of the StatCom, dc-dc chopper, and SMES coil is depicted in Fig. 2. In the figures, the units of resistance, inductance, and capacitance values are Ohm, Henry, and μ Farad, respectively.

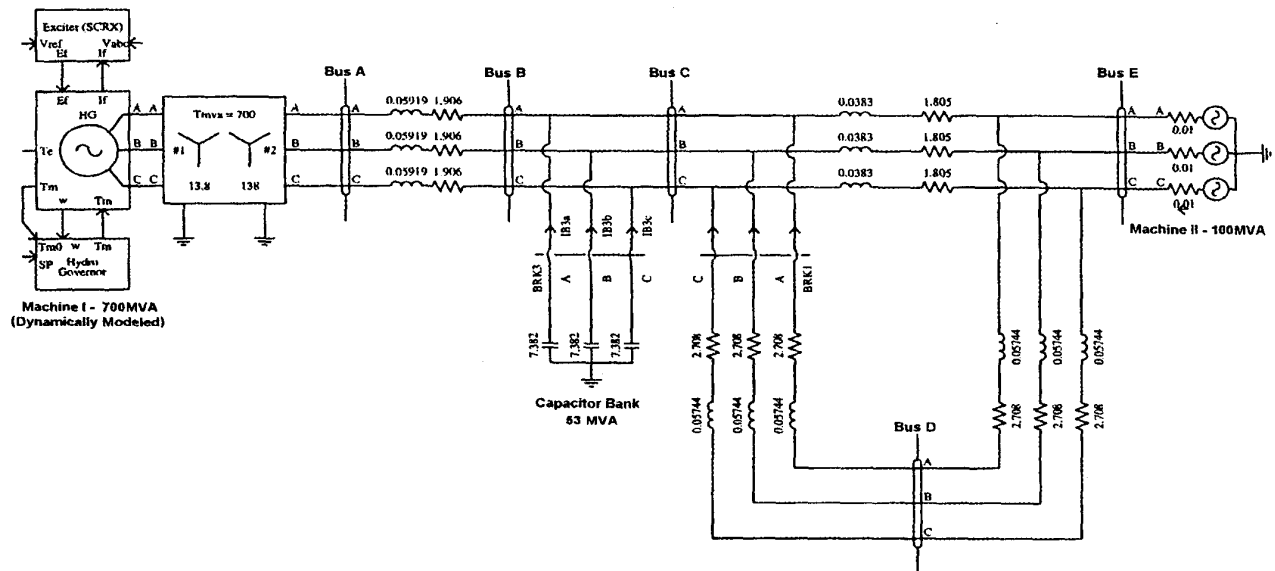

Fig. 1. AC System Equivalent

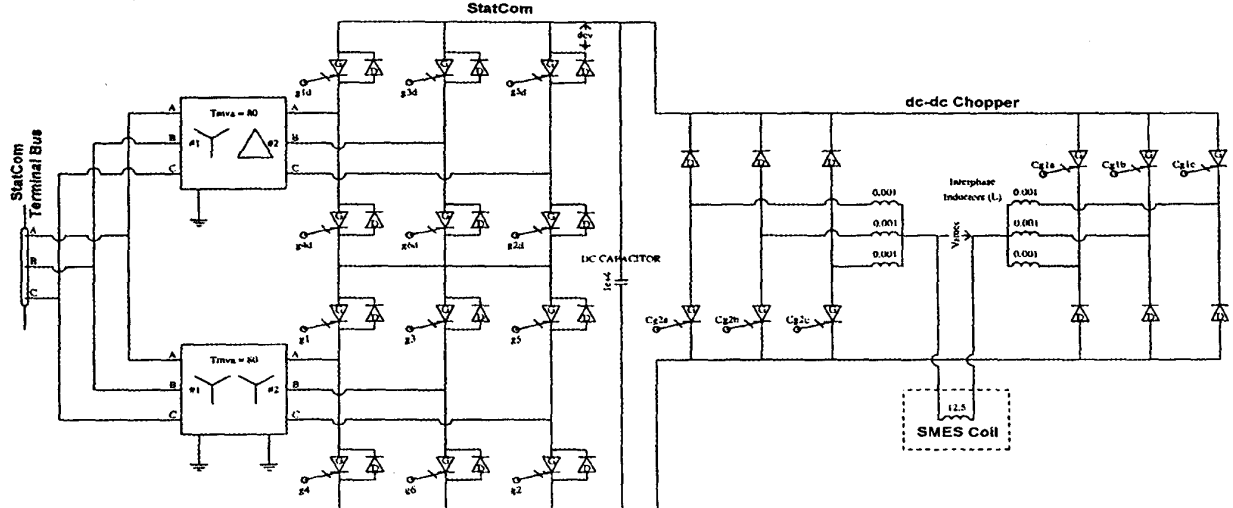

Fig. 2. Detailed Representation of the StatCom, dc-dc Chopper, and SMES Coil

A. The AC Power System

The ac system equivalent used in this study corresponds to a two machine system where one machine is dynamically modeled (including generator, exciter and governor) to be able to demonstrate dynamic oscillations. Dynamic oscillations are simulated by creating a three-phase fault in the middle of one of the parallel lines at Bus D (Refer to Fig. 1). A bus that connects the StatCom-SMES to the ac power system is named a StatCom terminal bus. The location of this bus is selected to be either Bus A or Bus B.

B. The StatCom

As can be seen from Fig. 2, two-GTO based six-pulse voltage source inverters represent the StatCom used in this particular study. The voltage source inverters are connected to the ac system through two 80 MVA coupling transformers, and linked to a dc capacitor in the dc side. The value of the dc link capacitor has been selected as 10mF in order to obtain smooth voltage at the StatCom terminal bus.

Fig. 3 shows the control diagram of the StatCom used in the simulation. The control inputs are the measured StatCom injected reactive power (SQ_{stat}) and the three-phase ac

voltages (V_a, V_b and V_c) and their per unit values measured at the StatCom terminal bus. The per unit voltage is compared with base per-unit voltage value (1 pu). The error is amplified to obtain reference reactive current which is translated to the reference reactive power to be compared with SQ_{stat} . The amplified reactive power error-signal and phase difference signal between measured and fed three phase system voltages are passed through a phase locked loop control. The resultant phase angle is used to create synchronized square waves.

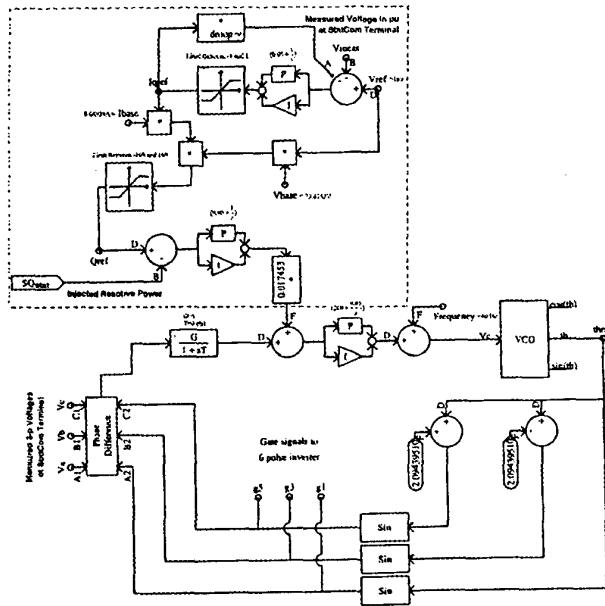

Fig. 3. StatCom Control

To generate the gating signals for the inverters, line to ground voltages are used for the inverter connected to the Y-Y transformer, whereas line to line voltages are utilized for the inverter connected to the Y-Δ transformer. This model and control scheme is partly based on the example case given in the EMTDC™/PSCAD™ simulation package, though some modifications have been made to meet the system characteristics. These modifications include change in transformer ratings and dc capacitor rating, tuning in control parameters and adding voltage loop control to obtain reference reactive power. It should be noted that the StatCom control does not make use of signals such as deviation in speed or power to damp oscillations, rather it maintains a desired voltage level at the terminal bus that the StatCom is connected to.

C. The DC-DC Chopper and SMES Coil

A SMES coil is connected to a voltage source inverter through a dc-dc chopper. It controls dc current and voltage levels by converting the inverter dc output voltage to the adjustable voltage required across the SMES coil terminal. The purpose of having inter-phase inductors is to allow balanced current sharing for each chopper phase.

A two-level three-phase dc-dc chopper used in the simulation has been modeled and controlled according to [16, 17]. The phase delay was kept 180 degrees to reduce the transient overvoltages. The chopper's GTO gate signals are square waveforms with a controlled duty cycle. The average voltage of the SMES coil is related to the StatCom output dc voltage with the following equation [18]:

$$V_{SMES-av} = (1-2d)V_{dc-av}$$

where V_{smes_av} is the average voltage across the SMES coil, V_{dc_av} is the average StatCom output dc voltage, and d is duty cycle of the chopper (GTO conduction time/period of one switching cycle).

This relationship states that there is no energy transferring (standby mode) at a duty cycle of 0.5, where the average SMES coil voltage is equal to zero and the SMES coil current is constant. It is also apparent that the coil enters in charging (absorbing) or discharging (injecting) mode when the duty cycle is larger or less than 0.5, respectively. Adjusting the duty cycle of the GTO firing signal controls the rate of charging/discharging.

As shown in Fig. 4, the duty cycle is controlled in two ways. Three measurements are used in this chopper-SMES control: SMES coil current (CI_{smes}); ac real power (SP_{meas}) measured at the StatCom terminal bus; and dc voltage ($dcvolt$) measured across the dc link capacitor. The SMES coil is initially charged with the first control scheme, and the duty cycle is set to 0.5 after reaching the desired charging level. The second control is basically a stabilizer control that orders the SMES power according to the changes that may happen in the ac real power. This order is translated into a new duty cycle that controls the voltage across the SMES coil, and therefore the real power is exchanged through the StatCom.

III. SIMULATION CASE STUDIES

In this section, the effectiveness of the StatCom-SMES combination is demonstrated by simulating several cases. These cases are given as subsections here. Dynamic oscillations of each case are generated by creating a three-phase fault at Bus D of Fig. 1. The plot time step is 0.001 sec for all the figures given in these cases.

A. No Compensation and StatCom-only Modes

A two-machine ac system is simulated. The inertia of the machine I was adjusted to obtain approximately 3 Hz oscillations from a three phase fault created at time=3.1 sec and cleared at time=3.25 sec. When there is no StatCom - SMES connected to the ac power system, the system response is depicted in the first column of Fig. 5 in the interval of 3 to 5 sec where first and second rows correspond to the speed of Machine I and ac voltage at Bus B, respectively. When a StatCom-only is connected, the response is given in the second column of Fig. 5. Since the StatCom is used for

voltage support, it may not be as effective in damping oscillations.

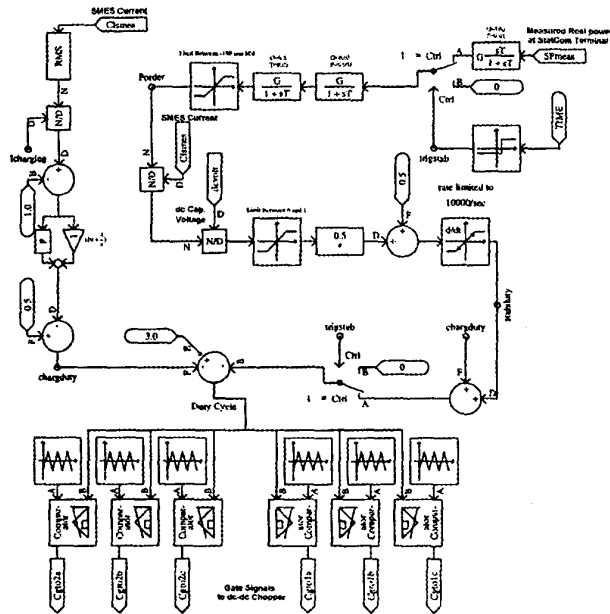

Fig. 4. SMES and Chopper Control

B. StatCom-SMES Located at Bus B

Now, the 100 MJ-96 MW SMES coil is attached to a 160 MVAR StatCom through a dc-dc chopper at *Bus B*. The SMES coil is charged by making the voltage across its terminal positive until the coil current becomes 3.6 kA. Once it reaches this charging level, it is set at the standby mode. In order to see the effectiveness of the StatCom-SMES combination, the SMES activates right after the three-phase fault is cleared at 3.25 sec. The dynamic response of the combined device to ac system oscillation is depicted in the third column of Fig. 5. The first plot shows the speed of Machine 1, and the second one gives the StatCom terminal voltage in pu when it is connected to *Bus B*. When compared no compensation case to StatCom-only case shown in Fig. 5, both speed and voltage oscillations were damped out faster.

C. StatCom-SMES Located at Bus A

The StatCom -SMES combination is now connected to the ac power system at a bus near the generator bus (*Bus A*). The same scenario drawn in Section III.B applies to this case. The results are shown in the fourth column of Fig.5. Compared to other two cases, StatCom-SMES connected to a bus near the generator terminal shows very effective results in damping electromechanical transient oscillations caused by a three-phase fault.

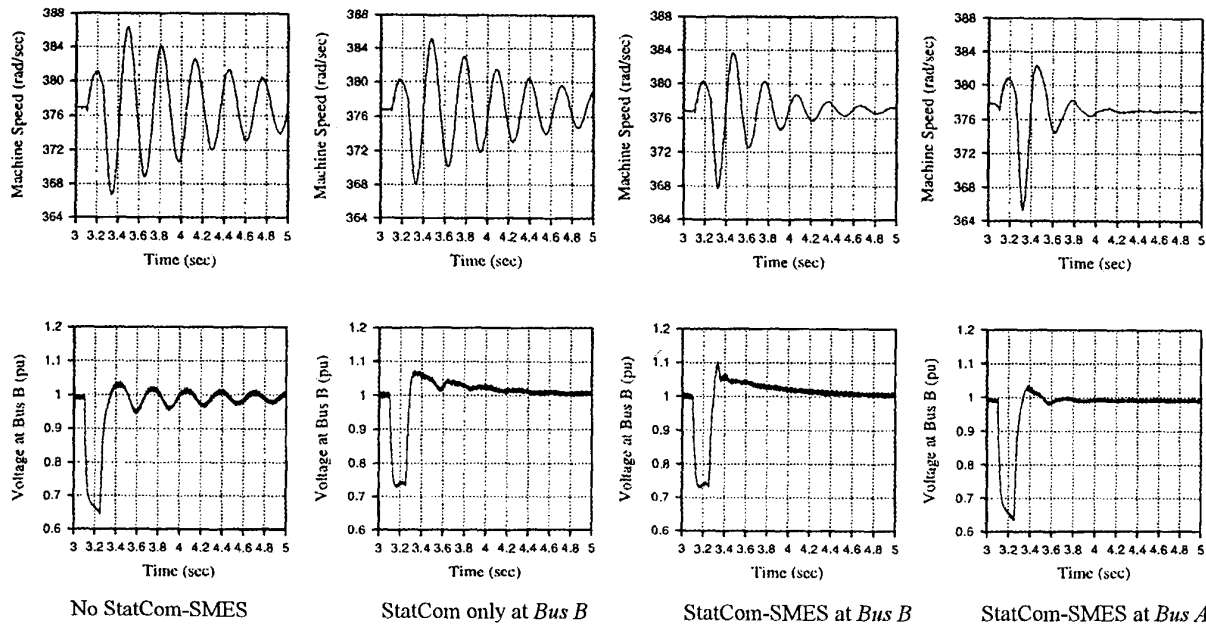

Fig. 5. Dynamic Response to AC System Oscillations

D. Load Addition at Bus B

In this case, the performance of the combined compensator was studied when a 100 MVA load at power factor of 0.85 is connected to *Bus B*. The existence of the load forced the combined compensator to be operated closer to its maximum rating. The performance of the compensator to ac system oscillations showed similar results as obtained in previous two cases. Again, when the combined compensator is located at *Bus A*, it shows better damping performance.

E. Reduced Rating in StatCom-SMES

While keeping the combined compensator location at *Bus B*, the performance of StatCom-only at full rating is compared to the performance of StatCom-SMES at reduced rating. The power rating of the SMES and StatCom was reduced to half of its original ratings (80 MVAR, 50 MW peak). The energy level of SMES was kept the same, however the real power capability of SMES was decreased. The SMES coil was charged until it reaches the desired charging current level, which took twice the time since the terminal voltage was lower. A three-phase fault is created at 5.6 sec for .15 sec, and the responses of the StatCom-SMES versus StatCom-only to the power swings are compared in Fig. 6.

This comparison shows that StatCom-SMES at the reduced rating can be as effective as a StatCom at the full rating in damping oscillations. On the other hand, the terminal voltage has not been improved. This requires higher reactive power support, but not as high as the full rating. Adding energy storage therefore can reduce the MVA rating requirements of the StatCom operating alone.

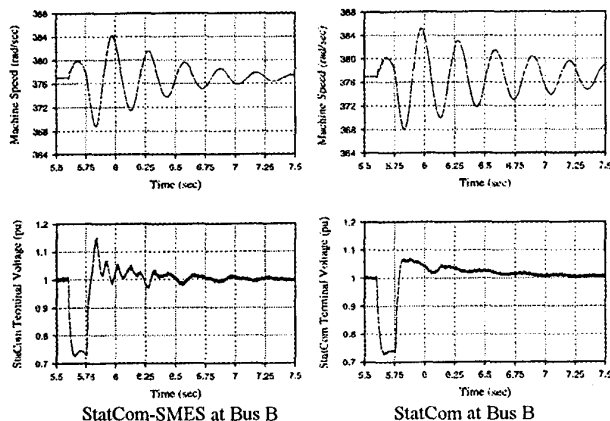

Fig. 6. 160 MVA StatCom vs. 80 MVA, 50 MW StatCom-SMES

IV. THE EFFECT OF REAL POWER IN DAMPING OSCILLATIONS

Low frequency oscillations following disturbances in the ac system can be damped by either reactive power or real

power injection/absorption. However, the reactive power injected to the system is dependent on the StatCom terminal voltage. On the other hand, the SMES is ordered according to the variation of the real power flow in the system. Damping power oscillations with real power is more effective than reactive power since it does not effect the voltage quality of the system. Better damping dynamic performance may be obtained if SMES is connected to the ac system through a series connected voltage source inverter (Static Synchronous Series Compensator) [7] rather than a shunt connected voltage source inverter. However, this is not a justifiable solution since it involves more cost.

V. SUMMARY AND CONCLUSIONS

This paper presents the modeling and control of the integration of a StatCom with energy storage, and its dynamic response to system oscillations caused by a three-phase fault. It has been shown that the StatCom with real power capability can be very effective in damping power system oscillations. Adding energy storage enhances the performance of a StatCom and possibly reduces the MVA ratings requirements of the StatCom operating alone. This can play an important role for cost/ benefit analysis of installing flexible ac transmission system controllers on utility systems.

This study used a SMES system as an energy storage source. It should be noted that the StatCom provides a real power flow path for SMES, but the controller of SMES is independent of that of the StatCom. While the StatCom is ordered to absorb or inject reactive power, the SMES is ordered to absorb/inject real power.

It was also observed that the location where the combined compensator is connected is important for improvement of the overall system dynamic performance. Although the use of a reactive power controller seems more effective in a load area, as stated in [7], this simulation study shows that a StatCom with real power capability can damp the power system oscillations more effectively, and therefore stabilize the system faster if the StatCom -SMES combination is located near a generation area rather than a load area.

VI. ACKNOWLEDGMENTS

This work is partly supported by the National Science Foundation, Department of Energy (Grant No. DE-FG36-94GO10011), and BWX Technologies, Inc. - Naval Nuclear Fuel Division. However, any opinions, findings, conclusions, or recommendations expressed herein are those of the authors and do not necessarily reflect the views of the sponsoring organizations.

VII. REFERENCES

- [1] K.K. Sen, "STATCOM - STATic synchronous COMPensator: Theory, Modeling and Applications,"

- IEEE Transactions on Power Delivery*, vol. 2, Feb. 1999, pp.1177-1183.
- [2] L. Gyugyi, "Dynamic Compensation of AC Transmission Lines by Solid-State Synchronous Voltage Sources," *IEEE Transactions on Power Delivery*, vol. 9, no. 2, April 1994, pp. 904-911.
 - [3] K. V. Patil, J. Senthil, J. Jiang, R.M. Mathur, "Application of Statcom for Damping Torsional Oscillations in Series Compensated AC Systems," *IEEE Transactions on Energy Conversion*, vol. 13, no. 3, September 1998, pp. 237-243.
 - [4] N. G. Hingorani, L. Gyugyi, *Understanding Concepts and Technology of Flexible AC Transmission Systems*, IEEE Press New York, 2000.
 - [5] C. Schauder, E. Stacey, M. Lund, L. Gyugyi, L. Kovalsky, A. Keri, A. Mehraban, A. Edris, "AEP UPFC Project: Installation, Commissioning and Operation of the ± 160 MVA StatCom (Phase I)," *IEEE Transactions on Power Delivery*, vol. 13, no. 4, October 1998, pp. 1530-1535.
 - [6] J. D. Rogers, R.I. Schermer, R.L. Miler and J.F. Hauer, "30 MJ Superconducting Magnetic Energy Storage System for Electric Utility Transmission Stabilization," *Proceedings of IEEE*, vol. 71, 1983, pp. 1099-1107.
 - [7] E. Larsen, N. Miller, S. Nilsson, S. Lindgren, "Benefits of GTO-Based Compensation Systems for Electric Utility Applications," *IEEE Transactions on Power Delivery*, vol. 7, no. 4, October 1992, pp. 2056-2062
 - [8] V. Karasik, K. Dixon, C. Weber, b. Batchelder, P. Ribeiro, "SMES for Power Utility Applications: A Review of Technical and Cost Considerations," *IEEE Transactions on Applied Superconductivity*, vol. 9, no. 2, pp.541-546, June 1999.
 - [9] W. V. Hassenzuhl, "Superconducting Magnetic Energy Storage," *Proceedings of the IEEE*, Vol.71, No.9, Sept 1983, pp.1089-1098.
 - [10] Y. Mitani, K. Tsuji, Y Murakami, "Application of Superconducting Magnetic Energy Storage to Improve Power System Dynamic Performance," *IEEE Transactions on Power Systems*, Vol.3, No.4, pp.1418-1425, Nov. 1988.
 - [11] S. Bonerjee, J. K. Chatterjee, S. C. Tripathy, "Application of Magnetic Energy Storage Unit as Load Frequency Stabilizer," *IEEE Transactions on Energy Conversion*, Vol.5, No.1, March 1990, pp.46-51.
 - [12] R.H. Lasseter, S.G. Jalali, "Dynamic Response of Power Conditioning Systems for Superconductive Magnetic Energy Storage," *IEEE Transactions on Energy Conversion*, vol. 6, no. 3, September 1991, pp. 388-393.
 - [13] S. F. Kral, M. Aslam, P. F. Ribeiro, X. Huang, M. Xu, "Superconducting Power Delivery Systems for Transmission and Distribution Applications," presented at the 57th American Power Conference, Chicago, April 1995.
 - [14] R.F. Giese, *Progress Toward High Temperature Superconducting Magnetic energy Storage (SMES) - A Second Look*, A Report by Argonne National Laboratory, December 1998.
 - [15] P. F. Ribeiro, "SMES for Enhanced Flexibility and Performance of FACTS Devices," *The Proceedings of the IEEE Summer Meeting*, July 1999.
 - [16] A.B. Arsoy, Z. Wang, Y.Liu, P.F. Ribeiro, "Transient Modeling and Simulation of a SMES Coil and Its Power Electronics Interface," *IEEE Transactions on Applied Superconductivity*, vol. 9, no. 4, pp.4715-4724, December 1999.
 - [17] A.B. Arsoy, "Electromagnetic Transient and Dynamic Modeling and Simulation of a StatCom-SMES Compensator in Power Systems" *Ph.D. Dissertation, Virginia Tech*, Blacksburg, VA, May 2000.
 - [18] D. Hassan, R.M. Bucci, K.T. Swe, "400MW SMES Power Conditioning System Development and Simulation," *IEEE Transactions on Power Electronics*, vol. 8, no. 3, July 1993, pp.237-249.

Dr. Aysen Arsoy has received her BS, MS and Ph.D. degrees in Electrical Engineering from Istanbul Technical University, Turkey in 1992, University of Missouri- Rolla in 1996, and Virginia Polytechnic Institute and State University in 2000, respectively. Her research interests include power electronics applications in power systems, computer methods in power system analysis, power system transients and protection, and deregulation. She is a member of the IEEE Power Engineering Society.

Dr. Yilu Liu (SM) is an Associate Professor of Electrical Engineering at Virginia Polytechnic Institute and State University. Her current research interests are power system transients, power quality, power system equipment modeling and diagnoses. Dr. Liu is the recipient of the 1993 National Science Foundation Young Investigator Award and the 1994 Presidential Faculty Fellow Award.

Dr. Shen Chen received his BS, MS, and Ph.D. degree in electrical engineering from Tsinghua University in Beijing, PRC in 1993, 1995, and 1998 respectively. He is currently a post-doctoral research fellow in the Electrical and Computer Engineering Department at University of Missouri-Rolla. His research interests include FACTS control and power system stability.

Dr. Zhiping Yang received his dual BS degrees in Electrical Engineering and Applied Mathematics and MSEE degree from Tsinghua University in 1994 and 1997, respectively. He received his Ph.D. degree from the University of Missouri-Rolla in Electrical Engineering in August 2000. He is currently employed by nVidea. His research interests include power system dynamic analysis, power electronics and applications in power systems.

Dr. Mariesa L. Crow (SM) received her BSE degree in electrical engineering from the University of Michigan in 1985, and her MS and Ph.D. degrees in electrical engineering from the University of Illinois in 1986 and 1989 respectively. She is presently a professor of Electrical and Computer Engineering at the University of Missouri-Rolla. Her research interests have concentrated on developing computational methods for dynamic security assessment, voltage stability, and the application of power electronics in bulk power systems.

Dr. Paulo F. Ribeiro (SM) received a BS in Electrical Engineering from the Universidade Federal de Pernambuco, Recife, Brazil, completed the Electric Power Systems Engineering Course with Power Technologies, Inc., and received the Ph.D. from the University of Manchester - UMIST, England. Presently, he is a Professor of Electrical Engineering at Calvin College, Grand Rapids, Michigan and a consultant engineer for BWX Technologies, Inc., Naval Nuclear Fuel Division.