



Missouri University of Science and Technology
Scholars' Mine

Electrical and Computer Engineering Faculty
Research & Creative Works

Electrical and Computer Engineering

01 Sep 2008

Single-Phase Bidirectional AC-DC Converters for Plug-in Hybrid Electric Vehicle Applications

Lisheng Shi

Andrew Meintz

Mehdi Ferdowsi

Missouri University of Science and Technology, ferdowsi@mst.edu

Follow this and additional works at: https://scholarsmine.mst.edu/ele_comeng_facwork

 Part of the [Electrical and Computer Engineering Commons](#)

Recommended Citation

L. Shi et al., "Single-Phase Bidirectional AC-DC Converters for Plug-in Hybrid Electric Vehicle Applications," *Proceedings of the IEEE Vehicle Power and Propulsion Conference (2008, Harbin, China)*, Institute of Electrical and Electronics Engineers (IEEE), Sep 2008.

The definitive version is available at <https://doi.org/10.1109/VPPC.2008.4677506>

This Article - Conference proceedings is brought to you for free and open access by Scholars' Mine. It has been accepted for inclusion in Electrical and Computer Engineering Faculty Research & Creative Works by an authorized administrator of Scholars' Mine. This work is protected by U. S. Copyright Law. Unauthorized use including reproduction for redistribution requires the permission of the copyright holder. For more information, please contact scholarsmine@mst.edu.

Single-Phase Bidirectional AC-DC Converters for Plug-in Hybrid Electric Vehicle Applications

Lisheng Shi, Andrew Meintz, and Mehdi Ferdowsi, *Member, IEEE*

Power Electronics and Motor Drives Laboratory

Missouri University of Science and Technology, Rolla, MO, USA

Email: lsx9d@mst.edu, almdkc@mst.edu, and ferdowsi@mst.edu

Abstract— Plug-in hybrid electric vehicles (PHEVs) are specialized hybrid electric vehicles that have the potential to obtain enough energy for average daily commuting from batteries. These batteries would be charged from the power grid and would thus allow for a reduction in the overall petroleum consumption. To implement the plug-in function, a single phase bidirectional ac-dc converter interfacing with the grid is essential. The implementation of a bidirectional ac-dc converter can allow for battery recharge from the grid, battery energy injection to the ac grid, and battery energy for ac power stabilization. In this paper, the basic requirements and specifications for PHEV bidirectional ac-dc converter designs are presented. Generally, there are two types of topologies used for PHEVs: an independent topology and a combination topology that utilizes the drive motor's inverter. Evaluations of the two converter topologies are analyzed in detail. The combination topology analysis is emphasized because it has more advantages in PHEVs, in respect to savings in cost, volume and weight.

Keywords— Plug-in hybrid electric vehicle, bidirectional ac-dc converter, battery charger, recharge mode and inverter mode.

I. INTRODUCTION

A plug-in hybrid electrical vehicle (PHEV) is an electric-drive hybrid vehicle with an all electric operating range. It combines batteries and internal combustion engines in an efficient manner. A PHEV uses electricity while the battery charge is in a high state. The average daily driving distance is 20-30 miles [1]. Primarily, the PHEV is designed to meet the daily driving requirements while only using electricity. At the same time, the PHEV provides a fuel tank and combustion engine to be used when an extended driving range is needed. Current battery technology allows a vehicle to have a battery capacity that is equivalent to 10 to 60 miles of driving [1]. This leads to the requirement of interface to the grid (through wall outlet). A battery charger is essential for PHEV. The battery charger should have two main functions: one is charging the battery to a proper state of charge (SOC), which will vary depending on battery chemistry but is considered to be near 100% for simplicity in this paper. This operation mode is called *recharge mode*. The other operation mode is called *inverter mode*, which means the battery energy can be inverted and flows back to the grid or for possibly supplying ac electricity locally. Therefore, the battery charger is a bidirectional ac-dc converter, *recharge mode* is ac to dc conversion and *inverter mode* is dc to ac conversion.

There are two types of battery chargers: off-board and on-board. An off-board charger is separated from the

PHEV and can allow for higher weight and volume at a lower cost to PHEV efficiency. In the PHEVs product development, the cost, volume and weight of the power electronics and electric machine (PEEM) system are important. The bidirectional ac-dc converter belongs to this PEEM system. In [2], the reduction targets are provided. Based on the present PHEV baseline, the cost, weight and volume of PEEM will reduce 46%, 20% and 36% respectively till 2010; 66%, 29% and 52% till 2015; 77%, 39% and 58% till 2020. Onboard charger design will affect the reduction targets. On-board charger is designed to combine with the whole PHEV system, which can benefit from the system optimization consideration; this can lead to higher performance and lower cost. The on-board charger will be discussed in this paper.

Several bidirectional ac-dc converter topologies can be used as the PHEV battery charger [3]. The specific topology chosen depends on the PHEV requirements, for example the efficiency, reliability, cost, volume and weight. There are two strategies for the bidirectional ac-dc converter design: one is that the bidirectional converter separates from the driving system. The other one is to combine the motor driving inverter with the converter. In section II, the general requirement to the bidirectional ac-dc converter is analyzed, which includes typical PHEV car prototypes under developed at present by companies and research institutes, battery power/energy requirement and typical PHEV bidirectional ac-dc converter profile. Roughly speaking, there are two types: one is independent of PHEV motor driving system; the other is the combination with the PHEV motor driving system. In section III, the operation modes of different topologies are given and the evaluations are provided. In section IV, two possible PHEV bidirectional ac-dc converter topologies are proposed by the author. Finally, section IV draws a final conclusion.

II. GENERAL REQUIREMENTS

A. PHEV Operation Duty Cycle

As mentioned above, PHEVs are designed for the majority of typical daily driving distance requirement. PHEVs have fuel tanks and internal combustion engines for the needs of longer trips. Recently, 10miles (PHEV10), 20miles (PHEV20), 40miles (PHEV40) and 60miles (PHEV60) prototypes are under research by main vehicle manufacturers and related research institutes. (PHEVxx: the "xx" stands for "xx" miles driving by battery energy only on urban driving profile). In USA, the median daily travel distance is about 33 miles; 31-39% of annual miles are the "first 20 miles" of daily driving; 63-74% is "first 60 miles"; average vehicle travel ~3.5 trips per day; most of the daily trips are less than 10 miles; 10%

of vehicles travel >100 miles daily. Fig. 1 is the typical PHEV Operation duty cycle [4]. There are three operation modes:

1) *Charge Depletion (CD) Mode*

During this operation mode, the net energy stored in batteries will decrease over a driving profile. The depletion process will be ended at about 20% SOC.

2) *Charge Sustaining (CS) Mode*

During this operation mode, the net energy stored in batteries may increase and decrease over a driving profile. However, by the end of operation duty cycle the energy stored in batteries will be the same as that of at the beginning of the period.

3) *Regular Recharge Mode*

In this mode, the batteries will be recharged by plug-in outlet. The grid ac energy is then converted to dc energy stored in the batteries. Usually, the recharge mode will be ended at 100% SOC.

B. *Battery Power/Energy Requirements*

Different kinds of vehicles have different requirements of batteries power/energy. Fig. 2 is the comparison among midsize HEV, PHEV and EV cars [5]. It can be seen that in PHEV, battery energy needed is less than that of EV and greater than HEV, which is in the range ~5-10kWh, that depends on the driving distance supporting by the battery energy. It is easy to know the power/energy (P/E) ratio of different kinds of vehicles for the same acceleration time periods. Typically, the PHEV P/E ratio is about ~5-18. For different kinds of vehicles, the energy requirements of electric driving are about: compact—0.26kWh/mil, midsize—0.30kWh/mil, SUV/Vans—0.38kWh/mil and full-size SUV—0.46kWh /mil.

C. *Typical PHEV Bidirectional AC-DC Converter Profile*

Considering the power electronics device efficiency, the motor inverter bus voltage is about: 200~400Vdc. In order to improve the efficiency further, higher bus voltage on the order of ~750V is proposed in some HEV prototypes.

Compared with battery electric vehicles (BEVs) and electric vehicles (EVs), PHEVs do not need fast charging because of the relatively smaller battery capacity in the PHEVs as well as the use of internal combustion engine and fuel tank for unexpected charging scenarios PHEVs can be recharged during the whole night or during the day when they are parked. The time periods for PHEVs recharging can last several hours. Thus the power ratings of the bidirectional ac-dc converters will be lower than the battery charger used in BEVs and EVs. Roughly, there are three bidirectional ac-dc converter arrays for selections [6]: (1) 120 VAC, 15 amp (~1.4 kW); (2).120 VAC, 20 amp (~2.0 kW); (3) 208/240 VAC, 30amp (~6 kW).

Table I gives the example of PHEV20 typical bidirectional ac-dc converter profile, which includes battery capacity, converter (charger) ratings and recharging time of four car models. it is interesting to note that parameters of power ratings and charging time may be conditioned by 1.2-1.4kW and 1or 2 hours respectively.

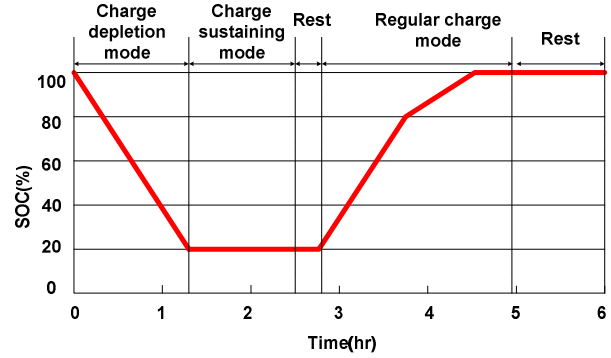

Figure 1. PHEV operation duty cycle. [4]

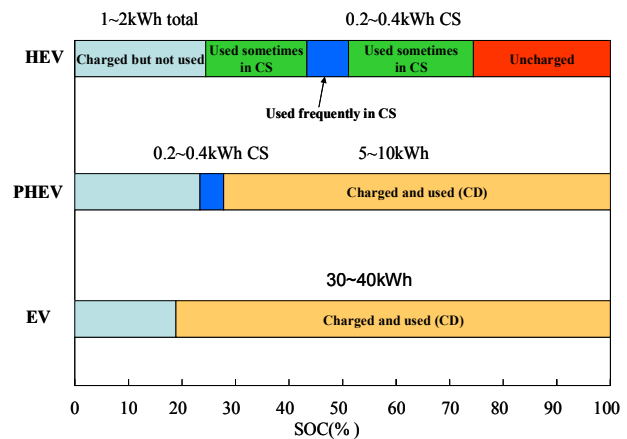

Figure 2. Battery Power/Energy Requirements; kWh: Battery energy for midsize car, CS: Charge Sustaining, CD: Charge Depleting

TABLE I. PHEV20 TYPICAL BATTERY CHARGER PROFILE

PHEV 20 Vehicles	Pack Size	Charger Circuit	Charging Time 20% SOC
Compact Sedan	5.1kWh	120VAC/15A	3.9-5.4hrs
Mid-size Sedan	5.9kWh	120VAC/15A	4.4-5.9hrs
Mid-size SUV	7.7kWh	120VAC/15A	5.4-7.1hrs
Full-size SUV	9.3kWh	120VAC/15A	6.3-8.2hrs

D. *Grid Connection and Other Requirements*

In recharge operation mode, since the bidirectional ac-dc converter operates as a nonlinear load on the grid, the related standards should be met, such as safety, reliability, EMC and harmonics requirements. The detailed PHEV battery charger requirements are listed in [7]. From [7], the recharge time from any SOC to 100% SOC should be less than 12 hours, and the preferred time should be less than 8 hours. The charger should operate correctly under the PHEV temperature environment: (1).Air temperature: 20°F to +120°F; (2). Paved surface temperatures: up to 150°F; (3). Occupant compartment temperatures: up to 170°F. The charger should operate normally under 120V or 208/240V single phase 60Hz ac source, with ±10% tolerance at rated input voltage. The applicable sections of UL Standards 2231-1 and 2231-2 should be met for the personnel protection.

The power factor should be not less than 0.95 and the THD (total harmonic distortion) current should be no more than 20% at rated load. In inverter operation mode, for the battery energy depletion, if the battery energy is feedback to the grid, then the bidirectional ac-dc converter is served as grid connected inverter. Then all the grid connection inverter standards should be satisfied by the bidirectional converter, such as the IEEE 1547 standard. Other aspects to be considered during the bidirectional ac-dc converter design include the efficiency, cost, volume and weight.

III. TYPICAL TOPOLOGIES ANALYSIS

Generally, a PHEV battery charger not only includes a bidirectional ac-dc converter, it also includes an EMI filter, and/or isolation transformer, control circuits unit and software. Since this paper focuses on the bidirectional ac-dc converter unit, more attention has been paid to the ac-dc bidirectional converter topologies. Based on the connection with the motor power electronics unit of PHEV, the topologies can be classified to two types: independent circuit topology and combination circuit topology.

A. Independent Circuit Topology

Fig. 3 is the block diagram of the independent circuit topology, which indicates the bidirectional ac-dc converter is an independent circuit unit. There is no relationship with the motor driving inverter. As shown in Fig. 3, the bidirectional converter which is parallel with the motor driving inverter is connected to the battery bus.

Several kinds of bidirectional ac-dc converters can be used for this topology [8]-[10]. Fig. 4 is a full bridge bidirectional ac-dc converter application example [11]. By implementing proper control strategy, the full bridge bidirectional converter can be operated in battery charge mode (ac-dc rectifier mode) or in inverter mode (dc-ac mode) respectively. In the battery charge mode, the line current is in phase with the line voltage. Thus the input power factor is unity. In the inverter mode, the output can be connected to the utility grid or ac load. By using the instantaneous voltage control and the average voltage control techniques [11], the ac output voltage is sinusoidal. If it is connected with the utility grid, the amplitude, frequency and phase of output voltage will be the same as the grid voltage (by synchronous circuit). In [11], the bidirectional ac-dc converter topology is applied to implement a small battery energy storage system (BESS). The dc side is connected to a 12Vx12 battery bank and the ac side is connected to an air conditioner. During the daily peak load period, the BESS supplies power to the air conditioner. At night, the BESS charges the battery. The steady-state voltage and current waveforms are given in [11] which show that the bidirectional ac-dc converter topology can be used in PHEV as an independent battery charger.

Since the bidirectional ac-dc converter is independent of motor drive inverter, the converter components such as power switches, capacitors and inductors can be easily designed. Further, the implementations of battery management and converter control strategies are simpler than the combination topology.

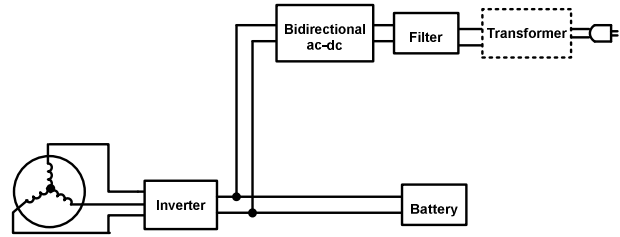

Figure 3. Independent battery charger topology

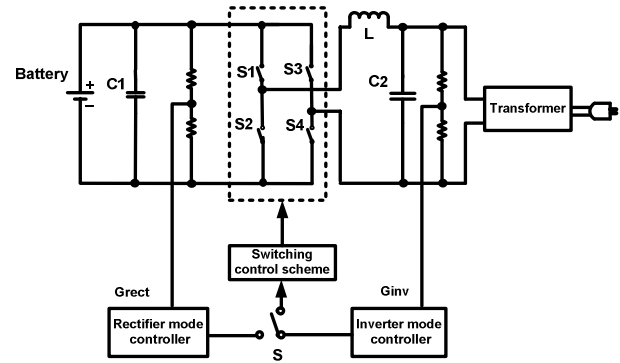

Figure 4. Bidirectional ac-dc converter as battery charger

On the other hand, there are obvious disadvantages. Since the bidirectional ac-dc converter is design independent of the motor driving system, this increases the components which lead to higher cost and larger volume/ weight.

B. Combination Circuit Topology

When batteries are recharged or operate in inverter mode for battery depletion, the PHEV motor is in off the state, thus the motor driving inverter is off. One can use the motor driving system (includes motor driving inverter and motor windings) to complete the function of the bidirectional ac-dc converter. Different topologies have been reported in [12]-[13]. Fig. 5 is the combination topology which means that there is no independent bidirectional ac-dc converter. In this topology, the motor winding(s) is used for the boost energy storage inductor (in ac-dc battery recharge mode), whereas, in dc-ac inverter mode, the motor winding(s) is used as the filter inductor. At the same time, the motor drive inverter is served as the bidirectional ac-dc converter. For this topology, there are two sub-types: two motor-driving-inverters system and one motor-driving-inverter system.

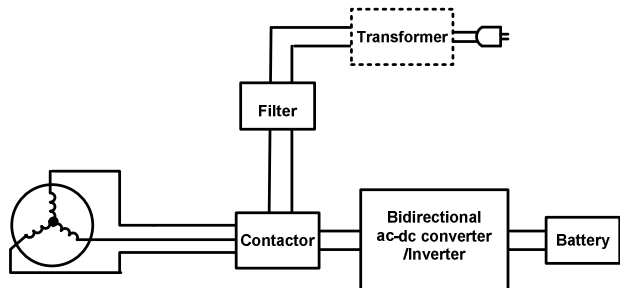

Figure 5. Combined battery charger topology

1) *Topology of Two Motor-Driving-Inverters with Two Motors*

Fig. 6 is the typical two-motor driving system topology. There are two motors M1 & M1' and two motor driving inverters A & A'. In [7], the similar topology is given. During the motor driving mode, the contactors K1, K2 and K3 are all turned off, while during battery recharge and inverter modes, the contactors K1, K2 and K3 are all closed.

To accomplish the bidirectional ac-dc converter functions, the two switches in one leg of each motor inverter are controlled on and/or off, and the other switches in other two legs should be in the off states. The two controlled legs of the two inverters are composed of the full bridge bidirectional ac-dc converter (the related two windings are served as energy storage inductors/filter inductors). As an example, one can let S3&S4, S5&S6, S3'&S4' and S5'&S6' off, while S1&S2 and S1'&S2' are controlled on/off. The motor windings L1 and L1' are used for the energy storage inductors/filter inductors. Similarly, on the proper control basis, in battery recharge mode, the line current can be controlled in phase with the line voltage (Power factor is close to unity and harmonics is low); in grid connection inverter mode, the output voltage can be controlled in phase with the grid voltage, while the amplitude is the same as the grid voltage.

2) *Topology of Two Motor-Driving-Inverters with One Motor*

In [12], one-motor driving system topology is presented, which is similar to Fig. 7. In Fig. 7, motor M has two sets connecting to the two inverters respectively. The operation principle is the same as the two-motor driving system topology.

To summarize case 1) and case 2), since the bidirectional ac-dc converter is the combination of the motor inverter and motor windings, there is no need other additional components. The cost is saved and the volume and weight are less than the independent topology.

The main disadvantage is the control complexity of the battery and the bidirectional ac-dc converter operation modes. Fortunately, most of the control work can be accomplished by software. Since the motor parameters and the motor driving inverts are designed based on the whole PHEV system, the components optimization is for the whole motor driving system, thus not based on the bidirectional ac-dc converter operation modes. However this will not affect the reliability and efficiency since the inverter power ratings are greater than the battery recharge mode/inverter mode requirements.

3) *Topology of One Motor-Driving-Inverter System*

Fig. 8 depicts the topology of a one-motor driving system [13]. During the motor driving mode, contactor K1 is closed and contactors K2 & K3 are opened, while during battery recharge/ inverter modes, contactor K1 is opened and contactors K2 & K3 are closed. Inverter switches S5&S6 and S1&S2 (or S3&S4) are controlled on/off, which composed of full bridge bidirectional ac-dc converter. Motor windings L3 and L1 (or L2) are served as the energy storage inductor/filter inductor. The battery management and bidirectional operation modes are the same as that of the above topologies.

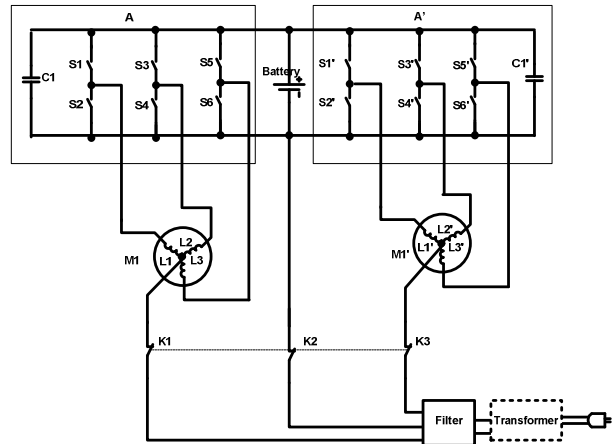

Figure 6. Two motor-driving-inverters with one motor

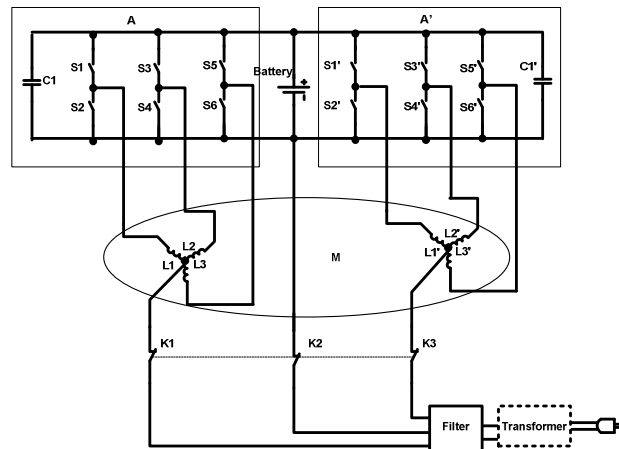

Figure 7. One motor-driving-inverter system

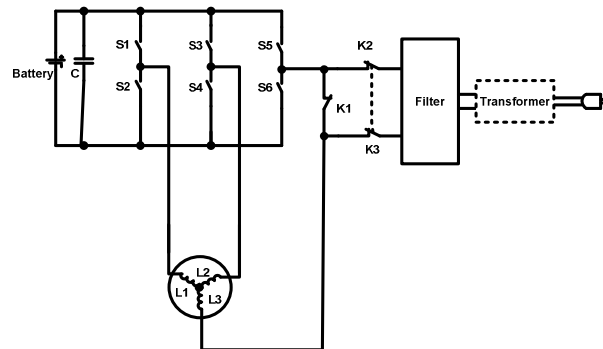

Figure 8. One motor-driving-inverter system

IV. CONCLUSIONS

The bidirectional ac-dc converter is the key power electronic unit for the plug-in function in PHEV. The basic electrical requirements and product specifications are summarized in this paper. Further, in the PHEV product development, performance, the cost, volume and weight are important indexes. A high performance lower cost bidirectional ac-dc converter with less volume and weight can benefit to the whole PHEV system. By combining the motor inverter and motor windings, the combination bidirectional ac-dc converter topologies have more advantages than the independent bidirectional converter topologies. The more appealing topology is the

one-motor driving inverter system. It is simpler to control than the two-motor driving inverter system topology.

REFERENCES

- [1] Tony Markel, "Advanced vehicle technology analysis and evaluation activities", http://www.leere.energy.gov/vehiclesandfuels/pdfsprogram/2005_adv_vehicle_tech.pdf, National Renewable Energy Laboratory, 2005.
- [2] Susan Rogers, "Plug-in hybrid electric vehicle, power electronics and power machines research and development activities", <http://www1.eere.energy.gov/vehiclesandfuels/avta/pdfs/phev/rogersphevworkshop.pdf>, June, 2007.
- [3] Bhim Singh, Brij N. Singh, Ambrish Chandra, Kamal Al-Haddad Ashish Pandey and Dwarka P. Kothari, "A review of single-phase improved power quality ac–dc converters", *IEEE Trans. Industrial Electronics*, vol. 50, no. 5, Oct. 2003. pp. 962-981.
- [4] Mark S. Duvall, "Plug-in HEV sprinter van battery considerations and test results", <http://www.arb.ca.gov/msprog/zevprog/symposium/presentations/duvall2.pdf>, ZEV technology symposium, Sept. 2006.
- [5] Ahmad Pesaran, "Battery choices and potential requirements for plug-in Hybrids", <http://www.nrel.gov/vehiclesandfuels/energystorage/pdfs/41328.pdf>, National Renewable Energy Laboratory, Jan. 2007.
- [6] M. S. Duvall, "Plug-in hybrid electric vehicle introduction and battery requirements", http://www.aqmd.gov/tao/ConferencesWorkshops/PHEV_Forum-07-12-06/2MarkDuvall-EPRI.pdf, Electric Power Research Institute, 2006.
- [7] D. Karner, R. Brayer, D. Peterson, M. Kirkpatrick and J. Francfort, "Plug-in hybrid electric vehicle (PHEV) integrated test plan and evaluation program", http://www1.eere.energy.gov/vehiclesandfuels/avta/pdfs/phev/draft_test_plan_phev_3-29-07.pdf, Mar. 2007.
- [8] S. Y. Hui, H. Shu-Hung Chung, and S. Chung Yip, "A bidirectional ac–dc power converter with power factor correction", *IEEE Trans. on Power Electronics*, vol.15, no.5, Sept. 2000, pp. 942-949.
- [9] J. Choi and J. Kim, "A bidirectional UPS with the performance of harmonic and reactive power compensation," *IEEE International Conference on Power Electronics and Drive Systems*, vol. 1, May 1997, pp. 323–328.
- [10] C. Qiao, K. M. Smedley, and F. Maddaleno, "A single-phase active power filter with one-cycle control under unipolar operation", *IEEE Trans. on Circuits and Systems*, vol. 51, no. 8, pp 1623-1630, Aug. 2004.
- [11] C. M. Liaw, T. H. Chen, T. C. Wang, G. C. Cho, C. M. Lee, and C. T. Wang, "Design and implementation of a single phase current-forced switching mode bilateral converter", IEEE proceedings electric power applications, pp 129-136, 1991.
- [12] Wally E. Rippel Altadena and Cocconi Glendora, "Integrated motor drive and recharge system", US patent 5099186. Mar. 24, 1992.
- [13] Alan G. Cocconi Glendora, "Combined motor drive and battery charger system", US patent 5341075. Aug.23, 1994. David Gabriel, "HEV charger/generator unit", US patent 6724100 B1, Apr. 20, 2004.