



Missouri University of Science and Technology
Scholars' Mine

Mechanical and Aerospace Engineering Faculty
Research & Creative Works

Mechanical and Aerospace Engineering

01 Jun 2007

Control Methods in DC-DC Power Conversion – A Comparative Study

Kai-tak Wan

Missouri University of Science and Technology

Jingsheng Liao

Mehdi Ferdowsi

Missouri University of Science and Technology, ferdowsi@mst.edu

Follow this and additional works at: https://scholarsmine.mst.edu/mec_aereng_facwork

 Part of the [Electrical and Computer Engineering Commons](#)

Recommended Citation

K. Wan et al., "Control Methods in DC-DC Power Conversion – A Comparative Study," *Proceedings of the IEEE Power Electronics Specialists Conference, 2007*, Institute of Electrical and Electronics Engineers (IEEE), Jun 2007.

The definitive version is available at <https://doi.org/10.1109/PESC.2007.4342111>

This Article - Conference proceedings is brought to you for free and open access by Scholars' Mine. It has been accepted for inclusion in Mechanical and Aerospace Engineering Faculty Research & Creative Works by an authorized administrator of Scholars' Mine. This work is protected by U. S. Copyright Law. Unauthorized use including reproduction for redistribution requires the permission of the copyright holder. For more information, please contact scholarsmine@mst.edu.

Control Methods in DC-DC Power Conversion – A Comparative Study

Kai Wan, *Student Member, IEEE*, Jingsheng Liao, and Mehdi Ferdowsi, *Member, IEEE*
Power Electronics and Motor Drives Laboratory
University of Missouri – Rolla
Rolla, MO 65409
Email: kwzm7@umr.edu, jl489@umr.edu, and ferdowsi@umr.edu

Abstract—Several control techniques for dc-dc power conversion and regulation have been studied in this paper. Analog approaches have briefly been described since the focus is the newly developed digital techniques. Principles of operation, advantages, and disadvantages of each control method have been described. Simulation results have been used to compare the performance and accuracy of digital control techniques.

I. INTRODUCTION

Dc-dc converters are widely used in regulated switch-mode dc power supplies and dc motor drive applications. Often the input to these converters is an unregulated dc voltage, which may have been obtained by rectifying the line voltage, and therefore will fluctuate due to changes in the line-voltage magnitude. Numerous analog and digital control methods for dc-dc converters have been proposed and some have been adopted by industry including voltage- and current-mode control techniques. It is of great interest to compare the dynamic response of these control methods as well as their advantages and disadvantages.

Voltage- and current-mode control techniques initially started as analog approaches. Voltage-mode control is a single-loop control approach in which the output voltage is measured and compared to a reference voltage, as shown in Fig. 1. On the contrary, current-mode control [1-8] has an additional inner control loop, as shown in Fig. 2, and enjoys several advantages over the conventional voltage-mode control including 1) improved transient response since it reduces the order of the converter to a first order system, 2) improved line regulation, 3) suitability for converters operating in parallel, and 4) over-current protection. However, the major drawback of the current-mode control is its instability and sub-harmonic oscillations. It is found that the oscillations generally occur when the duty ratio exceeds 0.5 regardless of the type of the converter. However, this instability can be eliminated by addition of a cyclic artificial ramp either to the measured inductor current or to the voltage control signal [1, 2].

Digital control of dc-dc converters has had a substantial development over the past few years [9-27]. Compared with analog techniques, digital control approaches offer a number of advantages including 1) programmability; since the control algorithms are realized by software different control algorithms can easily be programmed into the same hardware control system. When the design requirement is changed, it is

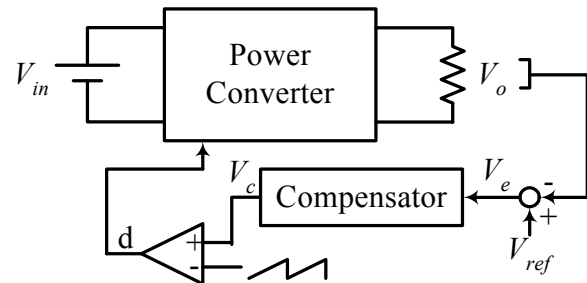

Figure 1. Block diagram of a voltage-mode controller

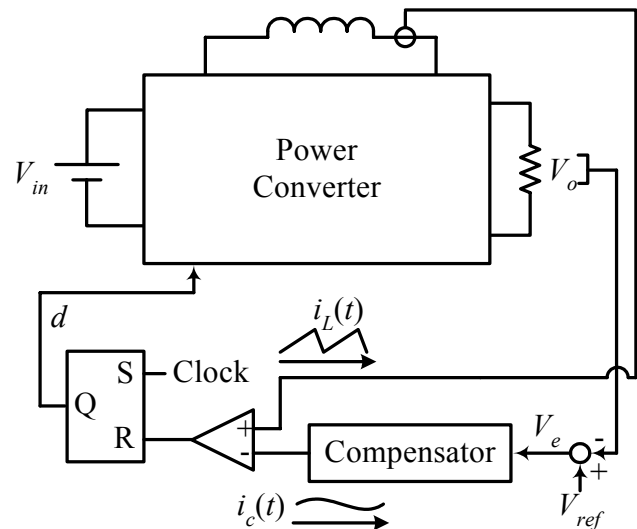

Figure 2. Block diagram of a current-mode controller

very easy and fast for digital controllers to change the corresponding software as a result of which the development time and cost will greatly be reduced. 2) High Flexibility; communication, protection, prevention, and monitoring circuits could be easily built in the digital control system. Furthermore, important operation data can be saved in the memory of digital control systems for diagnose. In addition, digital control systems ease the ability to connect multiple controllers and power stages. The system integration becomes easier. 3) Fewer components; in digital control system, fewer components are used compared with the analog circuit. Therefore, the digital control system is less susceptible to the environmental variations. Hence, digital control system has

better reliability than analog circuits. 4) Advanced control algorithms; most importantly, it is much easier to implement advanced control techniques into digital control system. Advanced control algorithms can greatly improve the dynamic performance of power converter system. The above mentioned advantages make digital control methods a viable option to meet the requirement for advanced power converters.

Different control methods for dc-dc converters are presented in this paper. The intention of this study is to compare the dynamic performance of these control methods applied to the same converter. In Section II, a brief description of analog approaches including voltage- and current-mode control methods is provided. Digital approaches are presented in Section III. Simulation results of the digital approaches and comparison between them are discussed in Section IV. Finally, Section V draws conclusions and presents an overall evaluation of the control methods.

II. ANALOG CONTROL TECHNIQUES

A. Voltage-mode Control of dc-dc Converter

As depicted in Fig. 1, voltage-mode control is a single-loop controller in which the output voltage is measured and compared to a reference voltage. The error between the two controls the switching duty ratio by comparing the control voltage with a fixed frequency sawtooth waveform. Applied switching duty ratio adjusts the voltage across the inductor and hence the inductor current and eventually brings the output voltage to its reference value.

Voltage-mode control of dc-dc converters has several disadvantages including 1) poor reliability of the main switch, 2) degraded reliability, stability, or performance when several converters in parallel supply one load, 3) complex and often inefficient methods of keeping the main transformer of a push-pull converter operating in the center of its linear region, and 4) a slow system response time which may be several tens of switching cycles.

B. Current-mode Control of dc-dc Converter

Compared with voltage-mode control, current-mode control provides an additional inner control loop control. The inductor current is sensed and used to control the duty cycle, as shown in Fig. 2 [7]. An error signal is generated by comparing output voltage V_o with reference voltage V_{ref} . Then this error signal is used to generate control signal i_c . The inductor current is then sensed and compared with control signal i_c to generate the duty cycle of the switch and drive the switch of the converter. If the feedback loop is closed, the inductor current becomes proportional with control signal i_c and the output voltage becomes equal to reference voltage V_{ref} .

C. Disadvantages of analog control techniques

Both voltage- and current-mode control techniques were initially implemented using analog circuits. Analog control has been dominant due to its simplicity and low implementation cost. Analog approaches have several disadvantages, such as large part count, low flexibility, low reliability, and sensitivity to the environmental influence such

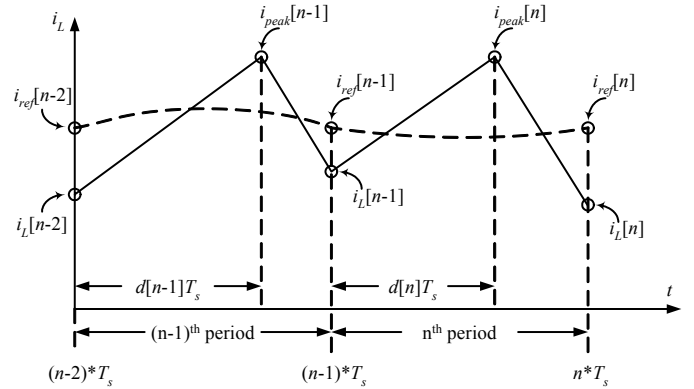

Fig. 3. Actual and reference inductor current waveforms (in this figure average current-mode control is shown)

as thermal, aging, and tolerance.

In addition, dynamic behavior of power converters is complicated due to the nonlinear and time varying nature of switches, variation of parameters, and fluctuations of input voltage and load current. Therefore, it is not easy to obtain an accurate model of the power converter systems. In analog implementations, power converters are usually designed using linearized models. Hence, it is difficult to design high performance control algorithms.

III. DIGITAL CONTROL TECHNIQUES

Several digital control techniques for dc-dc converters have been studied in this paper including current programming [9], estimative [10], predictive [11], dead-beat [12-15], and digital [16, 17] methods. Although, different names have been adopted to present these methods in the literature, this study proves that they are all based on dead-beat control theory. All of these methods try to make the peak, average, or valley value of the inductor current follow a reference signal hereafter named i_{ref} . In most applications, i_{ref} or control signal is provided by the voltage compensator.

1. General Equations of a Buck Converter

In this paper, without loss of generality, a buck converter is considered to compare the dynamic response of different digital control methods. Typical inductor current waveform of a buck converter operating in continuous conduction mode is shown in Fig. 3. Input and output voltages are slowly varying signals and can be considered constant during one switching period. Therefore one can write

$$V_o[n] \approx V_o[n-1] \text{ and } V_{in}[n] \approx V_{in}[n-1]. \quad (1)$$

Hence, for the sake of simplicity in notations in the following equations, input and output voltages are not shown as sampled signals even though they actually are.

Provided that the input and output voltage samples, the inductance value, and the switching period are known, sampled inductor current $i_L[n]$ at time nT_s , which is the end of the n^{th} period, can be described as a function of previous sampled value $i_L[n-1]$ and applied duty ratio $d[n]$. Final value of the inductor current can be described as

$$i_L[n] = i_L[n-1] + \frac{(V_{in} - V_o)d[n]T_s}{L} - \frac{V_o(1-d[n])T_s}{L} \quad (2)$$

Solving (2) for $d[n]$ would result

$$d[n] = \frac{L}{V_{in}T_s}(i_L[n] - i_L[n-1]) + \frac{V_o}{V_{in}} \quad (3)$$

Also, from (2), equations (4) and (5) can be derived.

$$i_L[n] = i_L[n-1] + \frac{V_{in}d[n]T_s}{L} - \frac{V_oT_s}{L} \quad (4)$$

$$i_L[n-1] = i_L[n-2] + \frac{V_{in}d[n-1]T_s}{L} - \frac{V_oT_s}{L} \quad (5)$$

Where (5) is similar to (4) with one sample shift. Another way of obtaining equation (4) is using discrete state space averaging as mentioned in [16]. The average model of a buck converter is

$$\frac{di_L}{dt} = \frac{1}{L}(d \cdot (V_{in} - V_o) + (1-d)(-V_o)) = \frac{d}{L}V_{in} - \frac{1}{L}V_o \quad (6)$$

Writing the equivalent difference equation for (6) would result (4). By combining (4) and (5), we can extend (4) to another switching period to obtain

$$i_L[n] = i_L[n-2] + \frac{V_{in}d[n-1]T_s}{L} + \frac{V_{in}d[n]T_s}{L} - \frac{2V_oT_s}{L} \quad (7)$$

Solving (7) for the sample of duty ratio would result

$$d[n] = \frac{L}{V_{in}T_s}(i_L[n] - i_L[n-2]) - d[n-1] + \frac{2V_o}{V_{in}} \quad (8)$$

Equation (9) can be derived based on (8) by one sample shift

$$d[n-1] = \frac{L}{V_{in}T_s}(i_L[n-1] - i_L[n-3]) - d[n-2] + \frac{2V_o}{V_{in}} \quad (9)$$

The following digital control techniques incorporate (3), (8), or (9) with their desired control objectives.

2. Valley Current Control (method 1)

This method is analog in nature [9]. However by changing the differential equations describing the dynamic of the power converter to difference equations, a digital controller can be utilized to realize the control objective.

2.1 Control Objective

In this control method, the required value for the duty cycle is calculated in the ongoing period to make sure that

$$i_L[n] = i_{ref}[n-1] \quad (10)$$

In other words, final value of the inductor current is expected to follow the initial value of the reference sampled at the beginning of the switching cycle. One period of delay is intrinsic to the dead-beat control law.

2.2 Control Method

Considering the control objective, by replacing $i_L[n]$ with $i_{ref}[n-1]$ in (3), one obtains

$$d[n] = \frac{L}{V_{in}T_s}(i_{ref}[n-1] - i_L[n-1]) + \frac{V_o}{V_{in}} \quad (11)$$

Therefore, in this control approach, inductor current i_L ,

reference current i_{ref} , and voltages are sampled at the beginning of each switching period. Then (11) is used to calculate the required duty ratio so that final value of inductor current at the end of the switching cycle $i_L[n]$ will be equal with sampled reference current at the beginning of the switching cycle $i_{ref}[n-1]$. It is worth mentioning that this approach assumes that the digital signal processor (DSP) is fast enough to calculate the duty ratio and apply it immediately. A similar approach has been presented in [26]; however, it needs more time in calculations and therefore previous samples of input and output voltages are used.

3. Average Current Control (method 2)

3.1 Control Objective

This method is introduced in [10]. The control objective is shown in equation (12). That is the average value of inductor current in each switching cycle follows the reference current sampled at the beginning of the same period.

$$\frac{1}{T_s} \int_{(n-1)T_s}^{nT_s} i_L(t) dt = i_{ref}[n-1] \quad (12)$$

In Fig. 3, the average value of inductor current during the n^{th} switching period can be calculated as

$$\begin{aligned} \frac{1}{T_s} \int_{(n-1)T_s}^{nT_s} i_L(t) dt &= \frac{1}{T_s} \left(\int_0^{d[n]T_s} (i_L[n-1] + \frac{V_{in} - V_o}{L} \cdot t) dt \right. \\ &\quad \left. + \int_0^{(1-d[n])T_s} (i_L[n-1] + \frac{V_{in} - V_o}{L} d[n]T_s - \frac{V_o}{L} \cdot t) dt \right) \\ &= i_L[n-1] + \frac{V_{in}d[n]T_s}{L} - \frac{V_{in}d^2[n]T_s}{2L} - \frac{V_oT_s}{2L} \end{aligned} \quad (13)$$

Using (4), (13) can be further simplified to

$$\frac{1}{T_s} \int_{(n-1)T_s}^{nT_s} i_L(t) dt = i_L[n] + \frac{V_oT_s}{2L} - \frac{V_{in}d^2[n]T_s}{2L} \quad (14)$$

In order to satisfy the control objective, (14) has to be solved for $d[n]$. However, (14) is nonlinear and solution would need a long calculation time and includes truncation error. In order to simplify the solution of (14), duty ratio is replaced by its steady state value [10].

$$d[n] \approx \frac{V_o}{V_{in}} \quad (15)$$

Applying (15) into (14) results

$$\frac{1}{T_s} \int_{(n-1)T_s}^{nT_s} i_L(t) dt \approx i_L[n] + \frac{TV_o}{2V_{in}} \cdot \frac{V_{in} - V_o}{L} \quad (16)$$

3.2 Control Method

This method assumes that the duty ratio calculated in every period can be used in the same period. To force the average value of the inductor current in the ongoing period to follow the reference sampled at the beginning of the same period and by combining (16), (12), and (3), one obtains

$$d[n] = \frac{L}{V_{in}T_s}(i_{ref}[n-1] - \frac{TV_o}{2V_{in}} \cdot \frac{V_{in} - V_o}{L} - i_L[n-1]) + \frac{V_o}{V_{in}} \quad (17)$$

Therefore, using (17) to find the new value for the duty ratio will make sure that the control objective is satisfied.

Valley current control, equation (11), and average current control, equation (17), can be compared using the following equation

$$d[n] = \frac{L}{V_{in} T_s} (i_{ref}[n-1] - i_L[n-1] - K) + \frac{V_o}{V_{in}} \quad (18)$$

where the expression for K can be found in Table I.

TABLE I
THE EXPRESSION FOR K IN DIFFERENT METHODS

Method	K
Valley Control	0
Average Control	$\frac{T_s V_o}{2V_{in}} \cdot \frac{V_{in} - V_o}{L}$

4. Delayed Valley Current Control (method 3)

4.1 Control Objective

This method is introduced in [11]. In this control method, the required value for the duty cycle is calculated in the previous period to make sure that

$$i_L[n] = i_{ref}[n-2] \quad (19)$$

In other words, the objective is to force the final (or valley) value of the inductor current in the ongoing period to follow the reference sampled at the beginning of the previous period. This way, the digital controller will have more time for the required calculation; however, there is an extra period of delay introduced to the system.

4.2 Control Method

This method assumes that the duty ratio of the ongoing period is calculated during the previous switching period. By substituting the control objective in (8), one obtains

$$d[n] = \frac{L}{V_{in} T_s} (i_{ref}[n-2] - i_L[n-2]) - d[n-1] + \frac{2V_o}{V_{in}} \quad (20)$$

If duty cycle $d[n]$ is calculated based on (20) during the previous period and applied to the converter during the n^{th} interval, then the inductor current will reach the reference current at the end of the n^{th} interval and the dead-beat law is reached within two switching periods. It is worth mentioning that the digital controller has a longer time, compared with methods 1 and 2, to calculate the new value for the duty ratio.

5. Delayed Peak Current Control

5.1 Control Objective

The control objective of this method is to force the peak value of the inductor current during the ongoing period to follow the reference sampled at the beginning of the previous period.

$$i_{peak}[n] = i_{ref}[n-2] \quad (21)$$

Where $i_{ref}[n-2]$ is the reference current sampled at the

beginning of the previous period. This control objective has less than two periods of time delay.

5.2 Control Method

Equations (22) and (23) can be obtained from Fig. 3.

$$i_{peak}[n] = i_{peak}[n-1] - \frac{V_o}{L} (1-d[n-1])T_s + \frac{V_{in} - V_o}{L} d[n]T_s \quad (22)$$

$$i_{peak}[n-1] = i_{peak}[n-2] - \frac{V_o}{L} (1-d[n-2])T_s + \frac{V_{in} - V_o}{L} d[n-1]T_s \quad (23)$$

Substituting (23) into (22) and solving for $d[n]$, one can find

$$d[n] = \frac{L}{(V_{in} - V_o)T_s} (i_{peak}[n] - i_{peak}[n-2]) - \frac{V_{in}}{V_{in} - V_o} d[n-1] - \frac{V_o}{V_{in} - V_o} d[n-2] + \frac{2V_o}{V_{in} - V_o} \quad (24)$$

Using control objective in (21), required duty ratio of the n^{th} period can be described as

$$d[n] = \frac{L}{(V_{in} - V_o)T_s} (i_{ref}[n-2] - i_{peak}[n-2]) - \frac{V_{in}}{V_{in} - V_o} d[n-1] - \frac{V_o}{V_{in} - V_o} d[n-2] + \frac{2V_o}{V_{in} - V_o} \quad (25)$$

Therefore, in this control approach, first peak value of the inductor current i_{peak} , reference current i_{ref} , and voltages are sampled in the previous period. Then (25) is used to calculate the required duty ratio so that the peak value of inductor current in the ongoing switching cycle $i_{peak}[n]$ satisfies control objective (21). Similar to analog approaches, this method is unstable when the duty cycle is greater than 0.5 [11].

6. Delayed Average Current Control

6.1 Control Objective

The control objective of this method is shown in (26). That is the average current value of n^{th} period should follow the reference current sampled at the beginning of the previous period.

$$\frac{1}{T_s} \int_{[n-1]T_s}^{[n]T_s} i_L(t) dt = i_{ref}[n-2] \quad (26)$$

6.2 Control Method

In [11], an approximation is made to solve (13) for $d[n]$. However, the solution is unstable when the duty ratio is greater than 0.5.

7. Prediction Current Control with Delay Compensation (method 4)

7.1 Control Objective

$$i_L[n] = i_{ref}[n-2] \quad (27)$$

This method is introduced in [12-15]. Its control objective is the same as method 3; however, the proposed approach is different. This control method has extended general equation (4) to four periods and the duty ratio is updated every two periods. The reference current is assumed as constant during these periods.

7.2 Control Method

In [12-15], it is assumed the calculated duty ratio can be

updated every other period. This would provide more time for the required calculations. Equation (28) can be found in [12]

$$d[n] = d[n-1] + \frac{L}{V_{in}T_s} (i_{ref}[n] - i_L[n]) \Big|_{d[n-1]} \quad (28)$$

Since reference current is assumed to be constant during a two period cycle, one can write

$$i_{ref}[n] = i_{ref}[n-2] \quad (29)$$

In this method, the current sampled at the end of n^{th} period is assumed to be calculated from the current sampled at the end of the last two periods, which is shown in (30).

$$i_L[n] \Big|_{d[n-1]} = 2 \cdot i_L[n-1] \Big|_{d[n-1]} - i_L[n-2] \Big|_{d[n-2]} \quad (30)$$

If (29) and (30) are extended over three sampling periods and duty ratio is assumed to be upgraded every other period, equation (31) can be derived.

$$\begin{aligned} d[n] &= d[n-2] + \frac{1}{2} \frac{L}{V_{in}T_s} (i_{ref}[n-2] - i_L[n-1]) \Big|_{d[n-2]} \\ &= d[n-2] + \frac{1}{2} \frac{L}{V_{in}T_s} (i_{ref}[n-2] - 4i_L[n-2] + 3i_L[n-3]) \end{aligned} \quad (31)$$

Another way of deriving (31) is to use (9) and (1). By substituting (9) into (8), equation (32) can be obtained

$$d[n] = \frac{L}{V_{in}T_s} (i_L[n] - i_L[n-2] - i_L[n-1] + i_L[n-3]) + d[n-2] \quad (32)$$

From assumption (30), it can be observed that

$$i_L[n] = \frac{1}{2} (i_L[n+1] + i_L[n-1]) \quad (33)$$

and

$$i_L[n-1] = 2 \cdot i_L[n-2] - i_L[n-3] \quad (34)$$

Substituting (33) and (34) into (31) and using the assumption of constant i_{ref} (35) can be obtained, which is the same as (31).

$$d[n] = \frac{L}{2V_{in}T_s} (i_{ref}[n-2] - 4i_L[n-2] + 3i_L[n-3]) + d[n-2] \quad (35)$$

Therefore, in this control approach, inductor current i_L , reference current i_{ref} , and voltages are sampled in the previous three periods. Then (35) is used to calculate the required duty ratio so that final value of the inductor current at the end of the switching cycle $i_L[n]$ is equal with sampled reference current at the beginning of previous switching cycle $i_{ref}[n-2]$. It is worth mentioning that the digital controller has at least two periods to calculate the new value for the duty ratio.

8. Compensated digital current control

8.1 Control objective

This control method is introduced in [16] and [17]. The control objective can be described in (36)

$$i_L[n] = i_{ref}[n-1] + m_c d[n] T_s \quad (36)$$

Where, m_c is a periodic compensating ramp.

8.2 Control method

By applying control objective (36) to general equation (3), one obtains

$$d[n] = \frac{L}{V_{in}T_s} (i_{ref}[n-1] + m_c d[n] T_s - i_L[n-1]) + \frac{V_o}{V_{in}} \quad (37)$$

From (37), the final equation of this control method can be obtained as

$$d[n] = \frac{1}{1 - \frac{Lm_c}{V_{in}T_s}} \left(\frac{L}{V_{in}T_s} (i_{ref}[n-1] + m_c d[n] T_s - i_L[n-1]) + \frac{V_o}{V_{in}} \right) \quad (38)$$

If $m_c=0$, then this control method is the same as valley current control (method 1). However, by applying periodic compensating ramp m_c , this control method resolves stability issues that may occur in method 1. In order to make the system stable, there are some requirements for m_c , which has been shown in Table II.

TABLE II
THE REQUIREMENTS FOR m_c

Converter type	Requirement
buck	$m_c > \frac{V_{in}}{L}$
boost	$m_c > \frac{V_o}{L}$
buck-boost	$m_c > \frac{V_{in} - V_o}{L}$

IV. SIMULATION RESULTS

To compare the dynamic response of the above mentioned control methods, computer simulations are used. The parameters of the buck converter used for this purpose are $V_{in}=6$ V, $V_{ref}=2$ V, $L=108$ μ H, $C=92$ μ F, and $R=3$ Ω .

Fig. 4 depicts the transient response inductor current for methods 1 through 4 if i_{ref} has a step change from 0.8 A to 1.2 A at $t=0.003$ s. All the currents are in Amps. The response of all methods is stable. It can be observed from Fig. 4 that the required time for methods 1 and 2 to track the reference is minimal. In method 1 valley value of the inductor current follows the reference whereas in method 2 average value of the inductor current tracks the reference. In methods 3 and 4 there is one extra period of delay. This is due to compromise for a longer calculation time. Also, due to the predictions used in method 4, inductor current takes a longer time to reach the steady state.

V. CONCLUSION

Several current programming approaches are described in this paper. The required equations are derived based on the dynamic equations of a buck converter. Control objective and control method of each method are described. Based on the obtained equations, it is easy to compare the studied control methods.

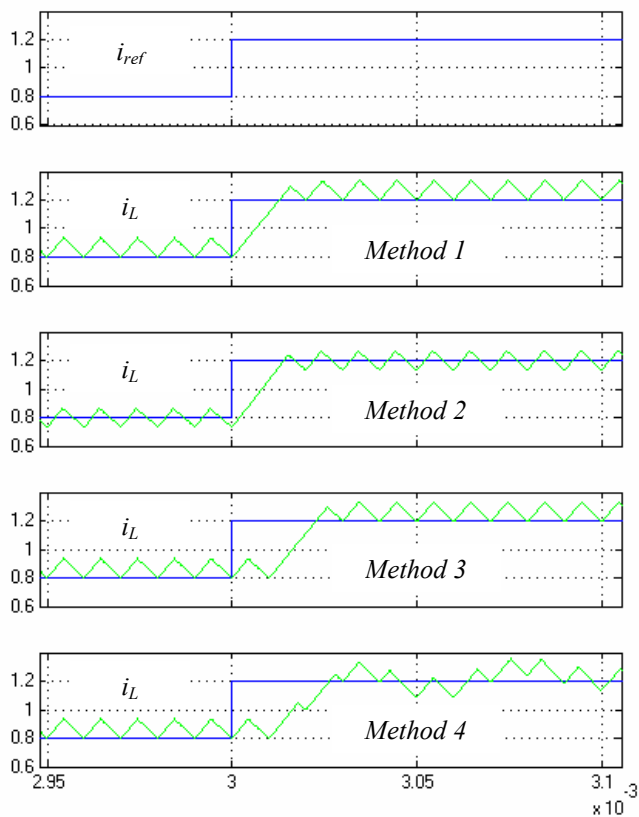

Figure 4. The transient response of methods 1 through 4 to a step change in i_{ref}

REFERENCES

- [1] P. Shanker and J. M. S. Kim, "A new current programming technique using predictive control," in *Proc. IEEE International Telecommunications Energy Conference*, Nov. 1994, pp. 428-434.
- [2] M. Ferdowsi, "An estimative current mode controller for dc-dc converters operating in continuous conduction mode," in *Proc. APEC*, Mar. 2006, pp. 19-23.
- [3] J. Chen, A. Prodic, R. W. Erickson, and D. Maksimovic, "Predictive digital current programmed control," *IEEE Trans. Power Electronics*, vol. 18, no. 1, pp. 411-419, Jan. 2003.
- [4] S. Bibian and J. Hua, "High performance predictive dead-beat digital controller for DC power supplies," *IEEE Trans. Power Electronics*, vol. 17, no. 3, pp. 420-427, May 2002.
- [5] S. Bibian and J. Hua, "Time delay compensation of digital control for DC switch mode power supplies using prediction techniques," *IEEE Trans. Power Electronics*, vol. 15, no. 5, pp. 835-842, Sep. 2000.
- [6] S. Bibian and J. Hua, "A simple prediction technique for the compensation of digital control time delay in DC switch mode power supplies," in *Proc. IEEE Applied Power Electronics Conference and Exposition*, Mar. 1999, pp. 994-1000.
- [7] S. Bibian and J. Hua, "Digital control with improved performance for boost power factor correction circuits," in *Proc. IEEE Applied Power Electronics Conference and Exposition*, Mar. 2001, pp. 137-143.
- [8] S. Chattopadhyay and S. Das, "A digital current-mode control technique for DC-DC converters," *IEEE Trans. Power Electronics*, vol. 21, no. 6, pp. 1718-1726, Nov. 2006.
- [9] S. Chattopadhyay and S. Das, "A digital current mode control technique for DC-DC converters," in *Proc. IEEE Applied Power Electronics Conference and Exposition*, Mar. 2005, pp. 885-891.
- [10] C. C. Fang and E. H. Abed, "Sampled-data modeling and analysis of the power stage of PWM dc-dc converters," *Technical Research Report*, 1999.

- [11] G.C. Verghese, C.A. Bruzos, and K.N. Mahabir, "Averaged and sampled-data models for current mode control: a re-examination," in *Proc. IEEE Power Electronics Specialists Conference*, 1989.
- [12] F. Huliehel and S. Ben-Yaakov, "Low-frequency sampled-data models of switched mode DC-DC converters power electronics," *IEEE Trans. Power Electronics*, vol. 6, no. 1, pp. 55-61, Jan. 1991.
- [13] C.C. Fang and E.H. Abed, "Sampled-data modeling and analysis of closed-loop PWM DC-DC converters," in *Proc. IEEE Int. Symp. Circuits and Systems*, May 30-Jun. 2, 1999, pp. 110-115.
- [14] G.C. Verghese, M.E. Elbuluk, and J.G. Kassakian, "A general approach to sampled-data modeling for power electronics circuit," *IEEE Trans. Power electronics systems*, pp. 45-55, 1986.
- [15] G. Francisco, C. Javier, P. Alberto, and M. Luis, "Large-signal modeling and simulation of switching DC-DC converters," *IEEE Trans. Power electronics*, vol. 12, no. 3, May 1997.
- [16] A. Simon and O. Alejandro, *Power-Switching Converters*, 2nd edition. CRC press, 2005
- [17] A. Brown and R.D. Middlebrook, "Sampled data modeling of switching regulators," in *Proc. IEEE Power Electronics Specialists Conference*, 1981, pp. 349-369.
- [18] J. Weigold and M. Braun, "Robust predictive dead-beat controller for buck converters," in *Proc. IEEE Int. Power Electronics and Motion Control*, Aug. 2006, pp. 951-956.
- [19] O. Kukrer and H. Komurcugil, "Deadbeat control method for single-phase UPS inverters with compensation of computation delay," in *Proc. IEE Electric Power Applications*, Jan. 1999, pp. 123-128.
- [20] C.W. Deisch, "Simple switching control method changes power converter into a current source," in *Proc. IEEE Power Electronics Specialists*, 1978, pp. 135-147.
- [21] S. Cuk and R.D. Middlebrook, *Advances in switched-mode power conversion*, TESLA co., Pasadena, 1982, vol. 1, 1982.
- [22] R.D. Middlebrook and S. Cuk, "A general unified approach to modeling switching-converter power stages," in *Proc. IEEE Power Electron.*, 1976, pp. 18-34.
- [23] R.W. Erickson, S. Cuk, and R.D. Middlebrook, "Large-signal modelling and analysis of switching regulators," in *Proc. IEEE Power Electron.*, 1982, pp. 240-250.
- [24] C.W. Deisch, "Simple switching control method changes power converter into a current source," in *Proc. IEEE Power Electronics*, 1978, pp. 135-147.
- [25] W. Tang, F.C. Lee, and R.B. Ridley, "Small-signal modeling of average current-mode control," *IEEE Trans. Power Electronics*, vol. 8, no. 2, pp. 112-119, Apr. 1993.
- [26] L. Dixon, "Switching power supply control loop design," in *Proc. Unitrode Power Supply Design Sem.*, 1991, pp. 7.1-7.10.
- [27] C. Philip, "Modeling average current mode control [of power convertors]," in *Proc. IEEE Applied Power Electronics Conference and Exposition*, Feb. 2000, pp. 256-262.