



Missouri University of Science and Technology
Scholars' Mine

Mechanical and Aerospace Engineering Faculty
Research & Creative Works

Mechanical and Aerospace Engineering

01 Jul 2008

Self-tuned Projected Cross Point – An Improved Current-Mode Control Technique

Kai-tak Wan

Missouri University of Science and Technology

Mehdi Ferdowsi

Missouri University of Science and Technology, ferdowsi@mst.edu

Follow this and additional works at: https://scholarsmine.mst.edu/mec_aereng_facwork

 Part of the [Electrical and Computer Engineering Commons](#)

Recommended Citation

K. Wan and M. Ferdowsi, "Self-tuned Projected Cross Point – An Improved Current-Mode Control Technique," *Proceedings of the IEEE Power Electronics Specialists Conference, 2008*, Institute of Electrical and Electronics Engineers (IEEE), Jul 2008.

The definitive version is available at <https://doi.org/10.1109/PESC.2008.4592482>

This Article - Conference proceedings is brought to you for free and open access by Scholars' Mine. It has been accepted for inclusion in Mechanical and Aerospace Engineering Faculty Research & Creative Works by an authorized administrator of Scholars' Mine. This work is protected by U. S. Copyright Law. Unauthorized use including reproduction for redistribution requires the permission of the copyright holder. For more information, please contact scholarsmine@mst.edu.

Self-Tuned Projected Cross Point - An Improved Current-Mode Control Technique

Kai Wan and Mehdi Ferdowsi, *Member, IEEE*

Missouri University of Science and Technology; Rolla, MO; USA

Email: kwzm7@mst.edu and ferdowsi@mst.edu

Abstract—Self-tuned projected cross point control for power electronic converters is introduced. Projected cross point control (PCPC) combines the advantages of both analog and digital current-mode control techniques. Despite several advantages, accuracy of the PCPC method depends on the power stage inductor value. However, ferromagnetic characteristics of the inductor core material make the inductor measurement inaccurate. Furthermore, the inductor value is subject to change due to temperature variations or other environmental effects. To overcome the dependence of the PCPC method on the inductor value, self-tuned PCPC approach is introduced in this paper. Unlike the conventional PCPC scheme, self-tuned PCPC method has excellent robustness against the variations of the inductor value. Hence, the average inductor current accurately follows its reference regardless of aging and temperature effects on the power stage inductor. Furthermore, the addition of the self-tuning mechanism does not interfere with the dynamic performance of the conventional PCPC method. Analytical analysis and simulation results show the superior accuracy and transient response of the self-tuned projected cross point control technique.

I. INTRODUCTION

Projected cross point control (PCPC) technique has been introduced in [1]. It enjoys the advantages of both analog and digital current-mode control techniques. Unlike traditional analog methods [2-10], it accurately controls the average value of the inductor current with no need for a current compensator or an external ramp. In addition, while resembling the deadbeat characteristics of digital current-mode controllers [11-29], the PCPC method does not suffer from computational time delay, limit cycling, and quantization and truncation errors.

Despite its excellent advantages, accuracy of the PCPC method depends on the power stage inductor value. Inductor value has to be measured and preprogrammed in the controller. However, measurement of inductor value may not be accurate enough due to its ferromagnetic characteristics. Furthermore, power stage inductor value is subject to change due to temperature, aging, and the dc current passing through it. Therefore, the PCPC approach will not be accurate enough if one fails to find or estimate the exact value of the inductor. In this case, there will be an offset between the inductor current and its reference. In other words, control objective will not be satisfied anymore. An improved PCPC method, named self-tuned PCPC technique, is introduced in this paper. The self-tuned PCPC method uses the error between inductor current and its reference to adjust the inductor value used in the controller. As a result, the control objective is

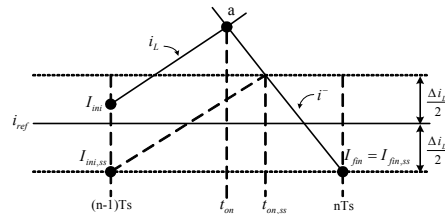

Fig. 1. Typical inductor current waveform of a buck converter.

satisfied and the improved controller is robust against variations of the power stage inductor value. Self-tuning does not interfere with line and load regulations; hence, the self-tuned PCPC method has identical regulation dynamic as the conventional one.

In Section II, principles of operation and implementation of the PCPC scheme are provided. Self-tuned PCPC method is discussed in detail in Section III. Simulation results are presented in Section IV. Finally, Section V draws the conclusions and presents an overall evaluation of the self-tuned PCPC approach

II. PROJECTED CROSS POINT CONTROL APPROACH

A. Introduction of the Projected Cross Point Control method

The PCPC method has been introduced in [1]. In this paper, without loss of generality, a buck converter is used to introduce the principles of operation of the PCPC method. A typical waveform of the inductor current is shown in Fig. 1. In this figure, i_{ref} indicates the reference current, which is the output signal of the voltage compensator. Without loss of generality and for the ease of demonstration in Fig. 1, reference current i_{ref} is drawn as a straight line. Desired inductor current in the steady-state operation is sketched in dashed lines. Associated labels are identified by an *ss* (steady-state) subscript. It is worth mentioning that, in average current-mode control and under steady-state conditions, initial and final values of the inductor current are identical and the average value of the inductor current follows the reference current. In Fig. 1, perturbed inductor current is sketched in solid lines. Considering average current-mode control, the control objective is to make sure that the final value of the inductor current returns to its steady-state value no matter what the initial value of the inductor current is. In other words

$$i_L(t = nT_s) = I_{fin,ss} = i_{ref} - \frac{\Delta i_L}{2} \quad (1)$$

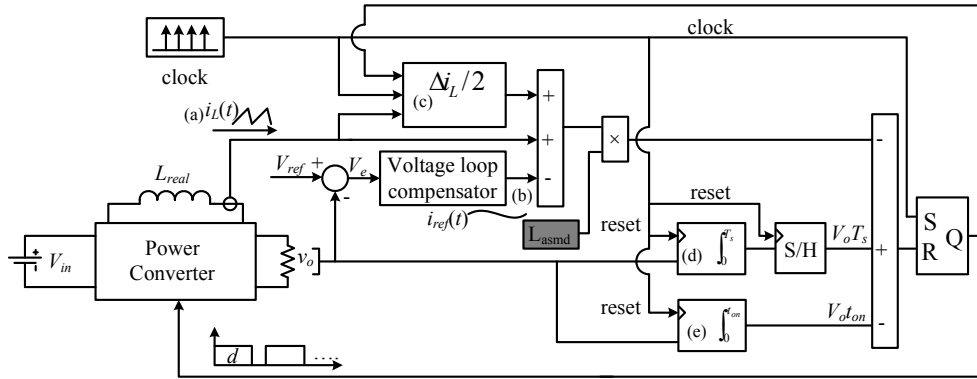

Fig. 2. Block diagram of the PCPC approach.

Where, $I_{fin,ss}$ is the final value of the inductor current in the steady state operation and Δi_L is the steady-state peak-to-peak ripple of the inductor current. It is obvious that if the control objective is satisfied, in the next switching cycle, average value of the inductor current will be identical with the reference; therefore, PCPC is an average current-mode control approach.

In order to satisfy the control objective, PCPC method needs to find the cross point of lines i_L and i^- (the inductor current in the negative slope area), which is indicated as point 'a' in Fig. 1. The equation for i^- is

$$i^- = i_{ref} - \frac{\Delta i_L}{2} + \frac{v_o}{L} T_s - \frac{v_o}{L} t. \quad (2)$$

In order to find t_{on} , the cross point of i_L and i^- will have to be identified; therefore

$$i_L(t = t_{on}) = i^-(t = t_{on}). \quad (3)$$

By combining (2) and (3), one obtains

$$i_L(t = t_{on}) = i_{ref} - \frac{\Delta i_L}{2} + \frac{v_o}{L} T_s - \frac{v_o}{L} t_{on}. \quad (4)$$

Equation (4) can be simplified as

$$L_{real} * [\underset{(a)}{i_L(t = t_{on})} - \underset{(b)}{i_{ref}(t = t_{on})} + \underset{(c)}{\Delta i_L / 2}] = \underset{(d)}{v_o T_s} - \underset{(e)}{v_o t_{on}} \quad (5)$$

The PCPC scheme solves (5) for t_{on} in real time as shown in the block diagram in Fig. 2. Different expressions in (5) that are labeled (a) through (e) are found as follows (a) inductor current i_L is measured, (b) reference current i_{ref} is the output of the voltage compensator, (c) Δi_L is the steady-state peak-to-peak ripple of the inductor current (details of finding Δi_L in real time is described in [1]), and (d) and (e) are simply found by integration as depicted in Fig. 2.

Having the voltage loop closed, waveform of the output voltage when there is a step change in input voltage V_{in} is shown in Fig. 3(a). For the sake of comparison, the output voltage waveforms of the same converter with the same voltage compensator controlled with the peak current-mode approach with three different values for the external ramp are also depicted in Figs. 3(b) through 3(d). In Fig. 3(b), the external ramp is slightly smaller than the negative slope of the inductor current ($-V_o/L = -10 * 10^{-6}$), which is $-8 * 10^{-6}$. Another output voltage waveform of the

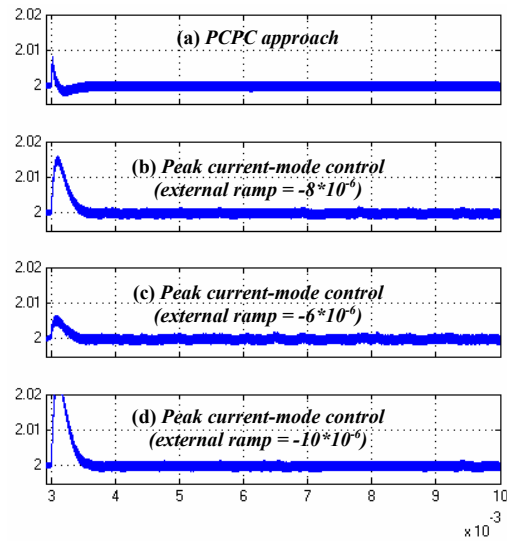

Fig. 3 Transients in the output voltage when input voltage V_{in} changes from 3 V to 6 V at 0.003 s.

peak current-mode control method with a smaller external ramp ($-6 * 10^{-6}$) is shown in Fig. 3(c). Output voltage waveform of peak current-mode control with external ramp equal to the negative slope of the inductor current is shown in Fig. 3(d). As in can be observed from Fig. 3(c), the transient response of the peak current-mode controller can get as good as that of the PCPC method; however, sub-harmonic oscillations appear. In order to eliminate the sub-harmonic oscillations, the external ramp needs to be increased which yields a higher output voltage overshoot (see Fig. 3(d)). Fig. 3 confirms that PCPC method has a superior transient performance for line regulation and steady state stability when compared with the peak current-mode control method. The inductor current and its reference for the PCPC and peak current-mode (with an external ramp of $-8 * 10^{-6}$) control methods when there is a step change in input voltage V_{in} are shown in Fig. 4. Simulation results prove that by using the PCPC method, the perturbation of the inductor current will disappear at the end of the first cycle guaranteeing inner loop stability and simultaneously providing the fastest possible transient response.

B. Sensitivity of the PCPC method to the power stage inductor variations

As it can be observed from (5), the PCPC method depends on power stage inductor value L_{real} . This method is not accurate if the precise value of L_{real} is not available. During the design process, the designer measures the value of the inductor used in the power stage and programs the controller based on that (L_{asmd}). This measurement may not be accurate enough; furthermore, in practical cases, value of the inductor is subject to change due to temperature variations or other environmental effects. In addition, inductor is a nonlinear component and it is hard to estimate its exact value at the operating point, which is variable itself. The effect of inaccuracies in the programmed value for the inductor in the PCPC method is depicted in Fig. 5. In this figure, using (5), reference current i_{ref} and the inductor current are sketched for three different cases.

L_{real} is the real value of the inductor and L_{asmd} is the value that has been used in the controller (see Fig. 2). It can be observed from Fig. 5 that when $L_{real} > L_{asmd}$, the average value of inductor current is greater than i_{ref} ($\langle i_L \rangle > i_{ref}$). On the other hand, when $L_{real} < L_{asmd}$, the average value of inductor current is less than i_{ref} ($\langle i_L \rangle < i_{ref}$). The control objective ($\langle i_L \rangle = i_{ref}$) is only satisfied if $L_{real} = L_{asmd}$; otherwise, there is an offset between $\langle i_L \rangle$ and i_{ref} . By observing these results, one would devise a self tuning approach to adjust L_{asmd} based on this offset.

III. SELF-TUNED PROJECTED CROSS POINT CONTROL APPROACH

Self-tuned PCPC is proposed to overcome the dependency of the control algorithm on the inductor value. The block diagram of the self-tuning module is depicted in Fig. 6. This block replaces the grey block in Fig. 2 (L_{asmd}). In Fig. 5, L_{ajds} refers to the adjusted inductor value which will be used in (5). The self-tuning mechanism can be described by

$$L_{ajds} = L_{asmd} - k \int (i_{ref} - i_L) dt. \quad (6)$$

As discussed in section II, there will be an offset between the average value of the inductor current ($\langle i_L \rangle$) and the reference current when the inductor value is not accurately measured and programmed. This offset is integrated and then enlarged by gain k . Then it is subtracted from L_{asmd} to adjust the inductor value used in (5). As a result of this, the inductor value in (5) can track the exact value of the power stage inductor and the average value of the inductor current can follow the reference current. Gain value k determines how fast the self-tuning will converge on the real value of the inductor. The larger the value of k is; the faster self-tuning will get.

IV. SIMULATION RESULTS

In order to observe the performance of the self-tuned method, the conventional and self-tuned PCPC methods are simulated and compared. Figs. 7 and 8 show that the average value of the inductor current cannot follow the reference current when the inductor value is not accurately programmed in the conventional PCPC method. The average value of i_L is 1 Amp.

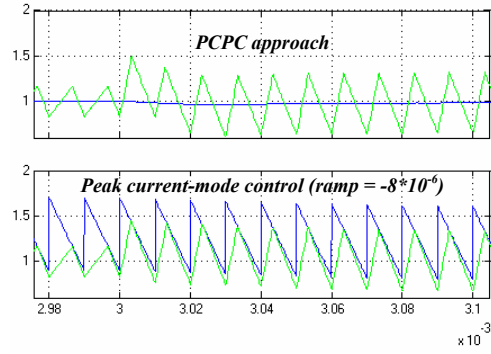

Fig. 4. Inductor current and its reference when V_{in} changes from 3 V to 6 V at 0.003 s.

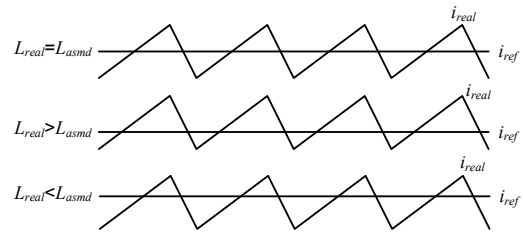

Fig. 5. Reference current and inductor current of the conventional PCPC method when the inductor value is not accurately measured.

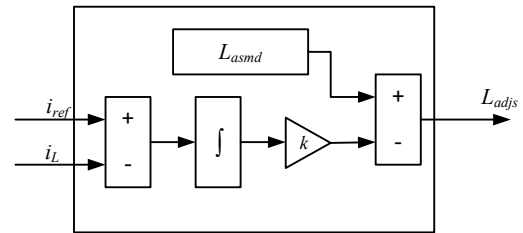

Fig. 6. Self-tuning module for the inductor value estimation.

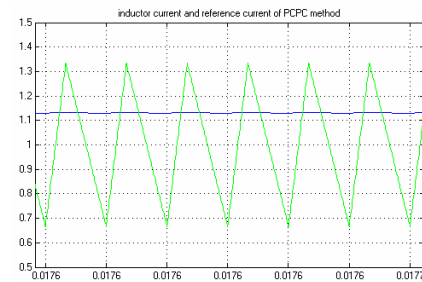

Fig. 7. Inductor current and reference current when $L_{real} < L_{asmd}$ using the conventional PCPC method.

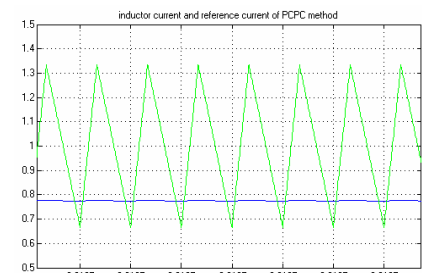

Fig. 8. Inductor current and reference current when $L_{real} > L_{asmd}$ using conventional PCPC method.

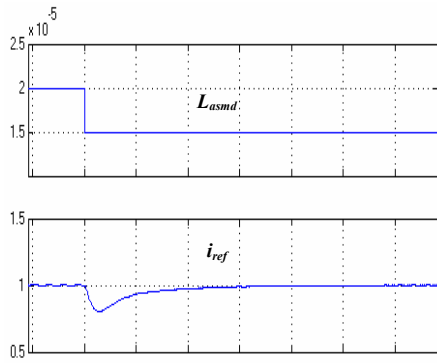

Fig. 9. Assumed inductor value and reference current of the self-tuned PCPC method when L_{asmd} changes from 20 μH to 15 μH at 0.01 s.

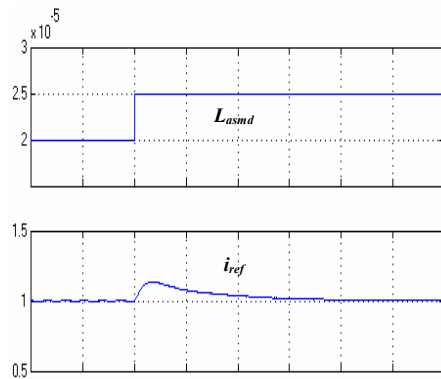

Fig. 10. Assumed inductor value and reference current of the self-tuned PCPC method when L_{asmd} changes from 20 μH to 25 μH at 0.01 s.

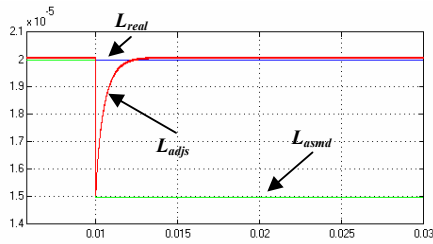

Fig. 11. L_{real} , L_{asmds} and L_{adjis} when L_{asmd} changes from 20 μH to 15 μH at 0.01 s.

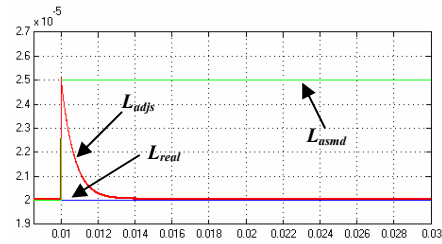

Fig. 12. L_{real} , L_{asmds} and L_{adjis} when L_{asmd} changes from 20 μH to 25 μH at 0.01 s.

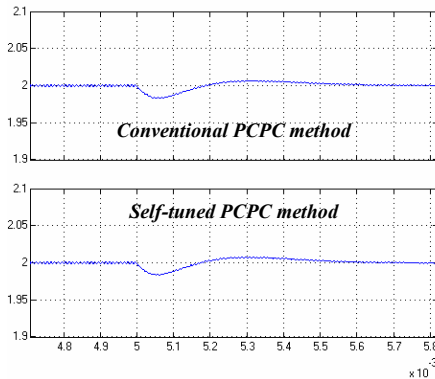

Fig. 13. Output voltage waveforms for PCPC and self-tuned PCPC methods when input voltage changes from 3V to 6V at 0.005 s.

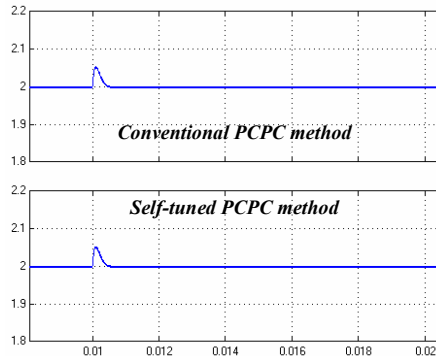

Fig. 14. Output voltage waveforms for PCPC and self-tuned PCPC methods when load changes from 2 Ω to 3 Ω at 0.01 s.

Fig. 9 depicts the reference current of the self-tuned PCPC method when L_{asmd} abruptly changes from 20 μH down to 15 μH at 0.01 s. Fig. 10 shows the reference current of the self-tuned PCPC method when L_{asmd} has an abrupt step-up change from 20 μH to 25 μH at 0.01 s. It can be observed from Figs. 9 and 10 that unlike the conventional PCPC method, the reference current of the self-tuned approach returns back to its normal value after a short transient.

Figs. 11 and 12 depict how the self-tuning module corrects the inductor value that is used in the control algorithm (L_{adjis}). L_{adjis} tries to follow the real value of the inductor (L_{real}) no matter what the assumed value is (see Fig. 6). In Figs. 11 and 12, L_{asmd} abruptly changes at 0.01 s.

In order to study the effect of self-tuning on line and load regulation of the PCPC method, output voltage waveforms for both PCPC and improved PCPC methods when input voltage changes from 3 V to 6 V and load

changes from 2 Ω to 3 Ω are shown in Figs. 12 and 13, respectively. Here, L_{asmd} and L_{real} have the same value. From Figs. 13 and 14, it can be seen that dynamic performance of the self-tuned and conventional PCPC methods are identical. By comparing the line and load regulation dynamic response of the self-tuned and conventional PCPC methods, one can observe that the addition of self-tuning does not interfere with the regulation characteristics of the conventional PCPC method.

V. CONCLUSION

Projected cross point control (PCPC) method using self-tuning is presented in this paper. The improved method has all of the advantages of the PCPC method while having an excellent robustness against the variations of the power stage inductor value. Simulation results prove its superior performance.

REFERENCES

- [1] K. Wan and M. Ferdowsi, "Projected Cross Point – a new average current-mode control approach," in *Proc. IEEE Applied Power Electronics Conference and Exposition*, Austin, Texas, Feb. 2008.
- [2] G. Francisco, C. Javier, P. Alberto, and M. Luis, "Large-signal modeling and simulation of switching dc-dc converters," *IEEE Trans. Power electronics*, vol. 12, no. 3, May 1997.
- [3] A. Simon and O. Alejandro, *Power-Switching Converters*, 2nd edition. CRC press, 2005
- [4] C. W. Deisch, "Simple switching control method changes power converter into a current source," in *Proc. IEEE Power Electronics Specialists*, 1978, pp. 135-147.
- [5] S. Cuk and R. D. Middlebrook, *Advances in switched-mode power conversion*, TESLA co., Pasadena, 1982, vol. 1, 1982.
- [6] R. D. Middlebrook and S. Cuk, "A general unified approach to modeling switching-converter power stages," in *Proc. IEEE Power Electron.*, 1976, pp. 18-34.
- [7] R. W. Erickson, S. Cuk, and R. D. Middlebrook, "Large-signal modeling and analysis of switching regulators," in *Proc. IEEE Power Electronics Specialists Conference*, 1982, pp. 240-250.
- [8] W. Tang, F. C. Lee, and R. B. Ridley, "Small-signal modeling of average current-mode control," *IEEE Trans. Power Electronics*, vol. 8, no. 2, pp. 112-119, Apr. 1993.
- [9] L. Dixon, "Switching power supply control loop design," in *Proc. Unitrode Power Supply Design Sem.*, 1991, pp. 7.1-7.10.
- [10] C. Philip, "Modeling average current mode control [of power converters]," in *Proc. IEEE Applied Power Electronics Conference and Exposition*, Feb. 2000, pp. 256-262.
- [11] C. C. Fang and E. H. Abed, "Sampled-data modeling and analysis of the power stage of PWM dc-dc converters," *Technical Research Report*, 1999.
- [12] G. C. Verghese, C. A. Bruzos, and K. N. Mahabir, "Averaged and sampled-data models for current mode control: a re-examination," in *Proc. IEEE Power Electronics Specialists Conference*, 1989.
- [13] F. Huliehel and S. Ben-Yaakov, "Low-frequency sampled-data models of switched mode dc-dc converters power electronics," *IEEE Trans. Power Electronics*, vol. 6, no. 1, pp. 55-61, Jan. 1991.
- [14] C. C. Fang and E. H. Abed, "Sampled-data modeling and analysis of closed-loop PWM dc-dc converters," in *Proc. IEEE Int. Symp. Circuits and Systems*, May 30-Jun. 2, 1999, pp. 110-115.
- [15] G. C. Verghese, M. E. Elbuluk, and J. G. Kassakian, "A general approach to sampled-data modeling for power electronics circuit," *IEEE Trans. Power electronics systems*, pp. 45-55, 1986.
- [16] A. Brown and R. D. Middlebrook, "Sampled data modeling of switching regulators," in *Proc. IEEE Power Electronics Specialists Conference*, 1981, pp. 349-369.
- [17] J. Weigold and M. Braun, "Robust predictive dead-beat controller for buck converters," in *Proc. IEEE Int. Power Electronics and Motion Control*, Aug. 2006, pp. 951-956.
- [18] O. Kukrer and H. Komurcugil, "Deadbeat control method for single-phase UPS inverters with compensation of computation delay," in *Proc. IEE Electric Power Applications*, Jan. 1999, pp. 123-128.
- [19] M. Ferdowsi, "An estimative current mode controller for dc-dc converters operating in continuous conduction mode," in *Proc. Applied Power Electronics Conference*, Mar. 2006, pp. 19-23.
- [20] K. Wan, J. Liao, and M. Ferdowsi, "Control methods in dc-dc power conversion – a comparative study," in *Proc. Power Electronics Specialists Conference*, Jun. 2007, pp. 921-926
- [21] P. Shanker and J. M. S. Kim, "A new current programming technique using predictive control," in *Proc. IEEE International Telecommunications Energy Conference*, Nov. 1994, pp. 428-434.
- [22] J. Chen, A. Prodic, R. W. Erickson, and D. Maksimovic, "Predictive digital current programmed control," *IEEE Trans. Power Electronics*, vol. 18, no. 1, pp. 411-419, Jan. 2003.
- [23] S. Bibian and J. Hua, "High performance predictive dead-beat digital controller for dc power supplies," *IEEE Trans. Power Electronics*, vol. 17, no. 3, pp. 420-427, May 2002.
- [24] S. Bibian and J. Hua, "Time delay compensation of digital control for dc switch mode power supplies using prediction techniques," *IEEE Trans. Power Electronics*, vol. 15, no. 5, pp. 835-842, Sep. 2000.
- [25] S. Bibian and J. Hua, "A simple prediction technique for the compensation of digital control time delay in dc switch mode power supplies," in *Proc. IEEE Applied Power Electronics Conference and Exposition*, Mar. 1999, pp. 994-1000.
- [26] S. Bibian and J. Hua, "Digital control with improved performance for boost power factor correction circuits," in *Proc. IEEE Applied Power Electronics Conference and Exposition*, Mar. 2001, pp. 137-143.
- [27] S. Chattopadhyay and S. Das, "A digital current-mode control technique for dc-dc converters," *IEEE Trans. Power Electronics*, vol. 21, no. 6, pp. 1718-1726, Nov. 2006.
- [28] S. Chattopadhyay and S. Das, "A digital current mode control technique for dc-dc converters," in *Proc. IEEE Applied Power Electronics Conference and Exposition*, Mar. 2005, pp. 885-891.
- [29] J. T. Mossoba and P. T. Krein, "Exploration of deadbeat control for dc-dc converters as hybrid systems," in *Proc. IEEE Power Electronics Specialists Conference*, 2005.