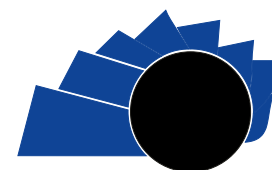

UNIVERSIDAD DISTRITAL
FRANCISCO JOSÉ DE CALDAS

Visión Electrónica

Más que un estado sólido

<https://revistas.udistrital.edu.co/index.php/visele/index>

Visión Electrónica

A RESEARCH VISION

Wearable device intended for detection of fog episodes in Parkinson's disease

Dispositivo vestible para identificar congelamiento de la marcha en Parkinson
**Laura Carolina Rozo Hoyos¹; Juan Pablo Pulgarín González²; Paula Andrea Morales Fandiño³;
Jonathan Gallego Londoño⁴**

INFORMACIÓN DEL ARTÍCULO

Historia del artículo:

Enviado: 19/11/2017

Recibido: 20/12/2018

Aceptado: 27/12/2018

Keywords:

Freeze Index

Freezing of Gait

Parkinson's disease

Predicting Device

Wearable device

ABSTRACT:

The episodes of Freezing of Gait (FOG) are a recurring symptom in people suffering from advanced stages of Parkinson's disease (PD). These are severe occurrences because they may cause falls to the patients, generating further traumas and concussions. In order to solve this yet ineffectively treated issue, this article describes the research that developed a device capable of predicting freezing episodes. On this project a wearable device was developed, which was able to predict freezing episodes based on the calculation of a freezing index (FI) determined by the signals obtained from an inertial measurement unit (IMU). This device was tested in three Patients and signals corresponding to normal gait and simulated Parkinson gait were taken. The results showed that FI obtained from Parkinson gait were much higher than those from a normal gait, validating this parameter as a key aspect in FOG prediction.

RESUMEN

Los episodios de congelamiento (FOG) son un síntoma de alta frecuencia en las personas que sufren de la enfermedad de Parkinson en un estado avanzado. Dichos episodios son un síntoma grave en los individuos pues pueden provocar caídas que le generen traumas o contusiones. En aras de dar una solución a esta problemática, que todavía no tiene un tratamiento de alta efectividad, se ha buscado desarrollar un dispositivo que haga una predicción de los episodios de congelamiento. En este artículo se desarrolla un dispositivo electrónico vestible capaz de predecir los episodios de congelamiento con base en el cálculo de un índice de congelamiento (FI) determinado a partir de señales de un sensor inercial IMU; este fue probado en una población de tres sujetos a quienes se les tomaron las señales mientras realizaban una marcha normal y mientras simulaban una marcha parkinsoniana. Los resultados arrojaron que los FI para marcha parkinsoniana son más elevados que los FI para marcha normal, dando validez a este parámetro como predicción de FOG.



Palabras clave:

Índice de congelación

Congelamiento de la Marcha

Enfermedad de Parkinson

Dispositivo de predicción

Dispositivo vestible

¹ Bioengineer, Universidad de Antioquia, Colombia. E-mail: laura.rozo@udea.edu.co ORCID: <https://orcid.org/0000-0001-9186-600X>

² Bioengineer, Universidad de Antioquia, Colombia. E-mail: paola.moralesf@udea.edu.co ORCID: <https://orcid.org/0000-0003-3645-2511>

³ Bioengineer, Universidad de Antioquia, Colombia. E-mail: jpablo.pulgarin@udea.edu.co ORCID: <https://orcid.org/0000-0003-1887-3259>

⁴ Bioengineer, Universidad de Antioquia, Colombia. MSc. Biomedical Engineering, RWTH Aachen University, Deutschland. Alemania. Current position: GIBIC research group, Bioengineering Program, Universidad de Antioquia. E-mail: jonathan.gallego@udea.edu.co ORCID: <https://orcid.org/0000-0002-9737-6850>

1. Introduction

Parkinson's disease (PD) is a neurological chronic degenerative process linked to deficiency in the production of dopamine. There are currently 230.000 known cases in Colombia and around of 6.3 million in the World, with an estimation that this condition will duplicate in 20 years, according to the World Health Organization (WHO) [1]. The freezing of gait (FOG) is present among the symptoms of patients with advanced stages. FOG is a condition where the patient loses instantly his capacity to walk, along with tremor, bradykinesia and rigidity [2] [3].

A FOG episode is a symptom to which special attention must be paid, because when it occurs, the patient reaches an almost absolute level of dependence on his caregiver due to a high probability of falls, concussions and hits that could seriously affect patient's life [4]. Currently, there are some treatments that seek to decrease FOG episodes. Those treatments include drugs and therapeutic procedures which are not completely successful [5] and become counterproductive as time goes by and the disease evolves. This situation motivates to look for additional treatments.

Previous researches about FOG indicate that using electronic devices with inertial signals measurement could help to predict FOG's events. Those studies have shown that during FOG episodes there are frequency components on signal's spectrum (3-8 Hz) related to those episodes (Usually between 5 to 8 Hz) and a prevalence of these events just after being on absolute rest. A Device designed by Moore et al [6] could detect up to 78% of FOG events. Other results displayed that those can detect FOG episodes with a 98.74% of specificity using Naïve Bayes and Random Forests algorithms [7]. Finally, another research evaluated that accelerometry could be used as the only resource to detect FOG episodes using a proper signal processing [8].

The purpose of this research is to bring together some of the main aspects of the previous researches mentioned as an alternative in FOG detection. On first place, it is described the materials and methods implemented to design and test the device. An Arduino MCU board, an inertial measurement unit (IMU) sensor and a Bluetooth module were used to send and process signals to get a parameter that indicates the start of a FOG episode on healthy subjects that simulated Parkinsonian gait. After

that, the results are exhibiting the coupling of the entire device, the signals obtained with it during the experiment, and the freeze index. Afterwards, there is a discussion where it could be seen that there was a great correspondence between experimental data and data reported on literature. Values of Freeze index where higher on Parkinsonian Gait ($f > 6$ Hz) while on normal Gait values of frequency where lower ($f < 3$ Hz). Finally, the conclusions mention the future work where a wearable device is proposed which is capable of visual and auditory stimulation intended to help patients with PD having FOG episodes. According to the results obtained, this device can detect episodes of Freezing of gait.

2. Materials and methods

2.1. Experimental design

Three healthy subjects were initially recruited. Those individuals must had not agreed with the following conditions:

- Be under age
- Consumed alcohol in the last 24 hours
- Received treatment with drugs like propranolol or primidone, among others.

Test subjects had to wear the wearable device at the height of the thigh just above knee.

The test was divided in 3 stages:

- **First Stage:** Consisted in remaining on a standing position without making any steps. This part was a control test, necessary to perform a signal preprocessing based on the fundamental signal to recognize which axis represented a greater change for a better analysis. This first step lasted 60 seconds.
- **Second Stage:** The subject had to perform a normal gait where default gait patterns with frequency spectrum looking for a comparison with the parkinsonian gait. The person had to walk for around 60 seconds through a corridor where only a 180° turn could be made.
- **Third Stage:** Individuals had to walk on parkinsonian gait (imitating tremor in the knee, short and quick steps, and additionally moving its center of mass a bit forward) for 60 seconds. Additionally, the subject had to

imitate one FOG episode for 10 seconds on the last 30 seconds of this stage. A short video was presented to the subjects explaining how the movement should be simulated.

2.2. Materials

To develop this research, it was necessary to implement a device with an IMU, an Arduino board, a Bluetooth module HC-06, Boost converters and a LiPo Battery as it is shown in Figure 1. The power source comes from the battery which is connected to the Boost converter in order to amplify the voltage from 3.7 V to 5 V because it is a requirement of Bluetooth HC-06, also this voltage is used for feed Arduino UNO which, additionally, has a voltage output of 3.3 V that is enough for feeding IMU. The device is capable of measuring acceleration in three axes, it also creates communication with a computer where signals are stored and processed with Matlab®.

Figure 1. Connections of a wearable device for FOG detection.

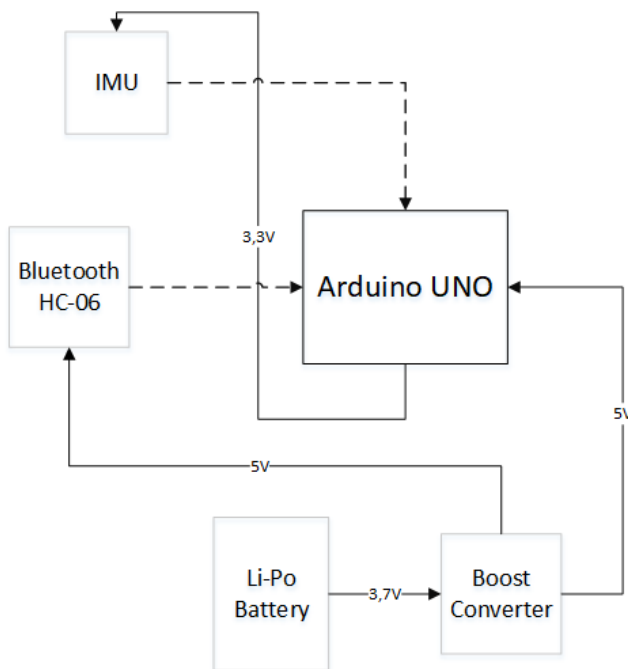

Source: own.

2.3. Signal Processing

It was necessary to perform signal processing to discard information that was not useful. On this opportunity, a Butterworth low pass filter with a

cutting frequency of 8 Hz was designed looking for values around 4 to 6 Hz on the power spectrum. These frequency values are characteristics of an abnormal gait. The Best signal processing filter was of order 19 according to *Buttord* function in Matlab® for an attenuation of 3 dB on 8 Hz (cutting frequency). It was adapted to the needs and was successfully applied to all signals. Signal's offset was attenuated using *dtrend* function in Matlab® because DC values for this signal are irrelevant.

2.4. Determination of Freeze index (FI)

To identify the FOG episodes, it was necessary to perform a 6 second window on 3 axes signals to calculate the spectrum in frequency over time of each of the 3 channels, since it will allow tracing the FI over time. To perform the Fast Fourier Transform, the *FFT* command was used with a sampling frequency (Fs) corresponding to the inverse of the time difference between two consecutive samples, which most of the time was 33.3 Hz. For each frequency spectrum, the area under the curve was calculated. First, from 0.5 to 3 Hz, corresponding to the locomotive band. Secondly, from 3 to 8 Hz, corresponding to the freezing band [4-6]. Finally, the Freeze Index was determined as the area under the curve of the squared of the freezing band, divided the area under the curve of the squared of the locomotor band [6], this could be seen on (1).

$$FI = \frac{(A_{Freeze\ Band\ dA})^2}{(A_{Locomotor\ Band\ dA})^2} \quad (1)$$

3. Results

Arduino Uno was selected for this application; although it isn't designed to be wearable it could be adapted to the project needs and could grant a greater stability on connections and artifacts. The physical device designed is shown in Figure 2. It was adjusted to each subject just over the right knee with anterolateral position.

The gait signals obtained with the device and filtered with Matlab® gave relevant information that were contrasted between the normal gait test and the Parkinsonian gait test. Figure 3. shows signals from normal gait and parkinsonian gait. The axis that best reflects the behavior of gait was the craniocaudal axis which matches with X axis of the accelerometer of the IMU as seen on Figure 2.

Figure 2. Wearable Device for FOG detection, image taken from a test subject to detect FOG. White arrow points out the X-axis.

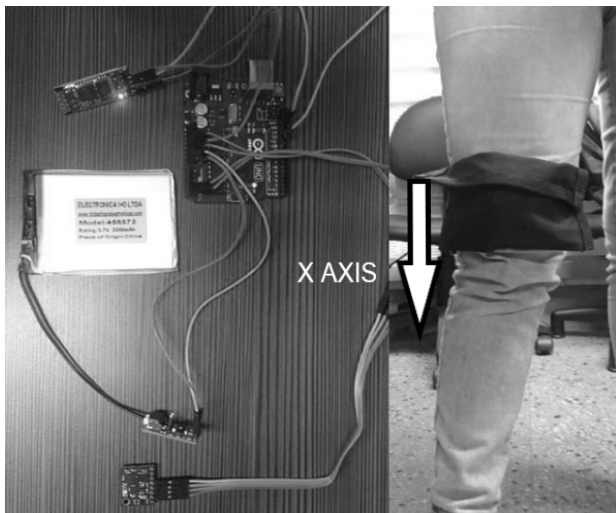

Source: own.

The Freeze Index is found on time through the windowing implemented during the determination of the signal's spectrum. This spectrum is useful to determine the Freeze Index later. Initially, the windowing was made with fixed windows, which resulted in a certain number of frequency spectra depending on the number of existing windows. Afterwards, a more accurate and better representation of the signal spectrum was obtained using a mobile window.

Figure 3. Signals of normal gait (up) and Simulated Parkinsonian gait (down) acquired by mean of the device for 20 seconds.

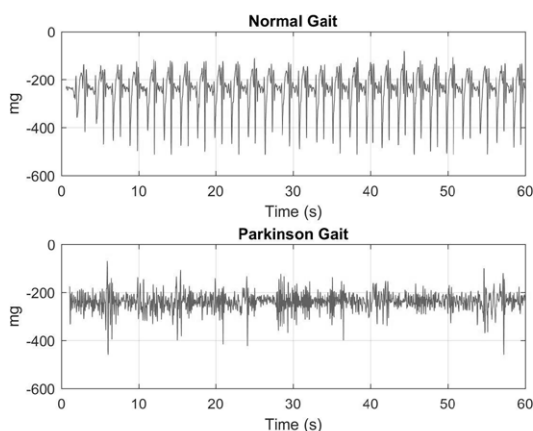

Source: own.

Freeze Indexes were obtained for each subject for each axis of the accelerometer and for the normal gait test and Parkinsonian gait test using the spectrum of frequency generated by the mobile window. Since there was a continuous result of the FI, the average values and the maximum values of the same were determined. These FI data could represent an episode. The results are shown in Table 1.

Table 1. Average and maximum values of Freeze Index of subjects registered in normal and Simulated Parkinsonian gait.

Index	Type of gait	Value	Subjects		
			1	2	3
Flx	Normal	Average	2,31	0,76	1,23
		Maximum	5,54	1,09	2,06
	Parkinsonian	Average	5,13	18,84	7,09
		Maximum	38,28	38,35	31,85
Fly	Normal	Average	4,14	1,03	0,88
		Maximum	9,6	1,59	1,68
	Parkinsonian	Average	4,98	4,96	5,63
		Maximum	25,11	10,37	19,7
Flz	Normal	Average	2,29	1,34	0,98
		Maximum	9,9	2,09	1,93
	Parkinsonian	Average	4,3	2,55	5,59
		Maximum	15,85	6,32	16,13

Source: own.

The FI obtained through the fixed Windows were plotted together with the signal on time for each subject. This could be observed on Figure 4.

Figure 4. Simulated Parkinsonian gait signal and FI, determined by fixed Windows, in time for a subject.

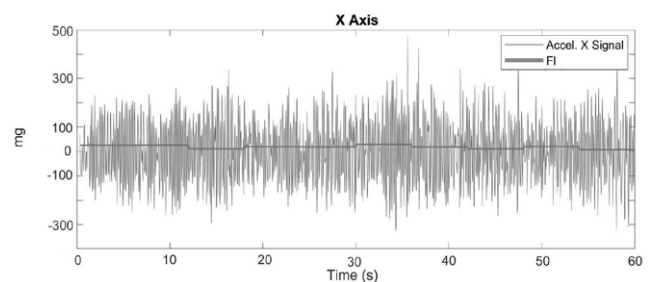

Source: own.

The normal gait signal of one of the subjects is shown in Figure 5, in which the Freeze Index was calculated using a mobile window of 200 samples. It can also be seen that the Freeze Index isn't present until approximately 5 seconds because the MCU cannot calculate signal's spectra until it has enough samples.

Figure 5. Normal gait signal along with Freeze Index correlation at instants of time using mobile Windows for a subject.

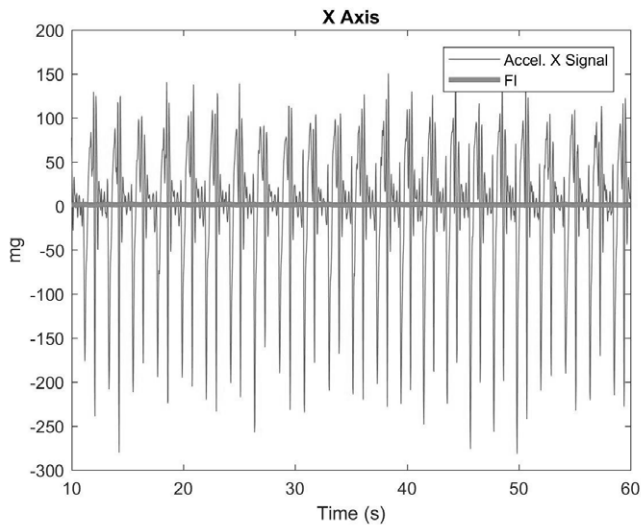

Source: own.

On Figure 6 it is shown the acceleration signal for the X axis plotted along with Freeze Index over time after being obtained using a mobile window of 200 samples during a test simulating the parkinsonian gait and an FOG episode while using the device.

Figure 6. Simulated Parkinsonian gait signal together with the correspondence of Freeze Index using mobile windows for a subject. The black line indicates the period during which a freezing episode was simulated.

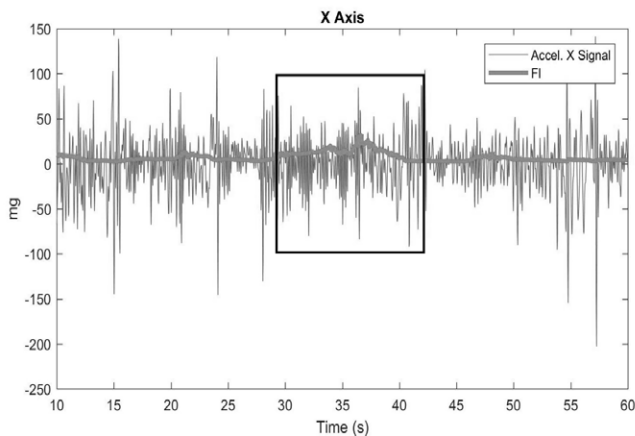

Source: own.

4. Discussion

The Arduino Uno MCU was the core of the designed device. Through this, all modules necessary for its operation were linked. However, the I2C communication that the MCU had with the IMU and the loss of data that existed on Bluetooth communication during the execution of tests, made a non-constant frequency of sampling of the device over time, which generated the need to discard a large part of acquired signals and therefore a small size database.

The signals obtained from parkinsonian gait and normal gait for a subject shown in Figure 3 differ greatly, since parkinsonian gait clearly has a marked behavior with higher frequencies along gait cycle. The same behavior was seen for the other subjects. Steps could be easily identified on the normal gait, corresponding to the two highest peaks of the signal; however, in the parkinsonian gait this behavior isn't observed, there are not two large peaks that mark the gait cycle, since the steps under this condition are not large and fast, due to the subject is dragging his feet.

It is also important to highlight the presence of a low frequency contribution in the band from 0.5 to 3 Hz to understand the result of the Freeze Index.

On Table 1 it is clearly observed that the axis that provides the highest Freeze Index is the x axis corresponding to the craniocaudal axis from subjects and from which this result was expected, thanks to the way the accelerometer was arranged. This axis represents the broadest movements of the leg in the knee height in the gait.

On the other hand, Sijbert obtained FI values for subjects who had Freezing events during the gait, which are found between 6 and 16, while for this device, the FI values obtained for the simulating parkinsonian gait are greater. However, comparing the FI of normal gait with the FI of the Parkinsonian gait obtained using the device, it can be observed that freezing indexes of Parkinsonian gait are always higher than those obtained from normal gait.

On Figure 4 it could be observed the determined FI thanks to steady windows. There were sections in which the FI was higher indicating a probable FOG episode. Nevertheless, this is not accurate since

the episodes to be predicted could last less than the length from a steady window.

To have a better trend from discrete time lapses in which a FOG episode could be present, a mobile window is used instead of several steady windows, suppressing a possible limitation where there is not a continuous sampling of patient's signal which could lead to a wrong diagnosis. Because of that, it is decided to use a continuous sampling method on time and obtain a low-discretized and time-tested signal in patients with Parkinson's disease to be able to adequately monitor patient's signals over time. Signals shown in Figure 6 display an evolution of FI (dark gray line) over time, demonstrating an easily noticeable difference between normal gait and Parkinsonian gait.

It is observed in Figure 5 that there is a uniform (gray dark line) gait signal, which corresponds to a signal from a healthy person. The Freeze Index was calculated over time and it was also plotted in the same figure resulting in an almost constant value. The case is different on the simulated Parkinsonian gait shown in Figure 6 where acceleration signals on time are more irregular with higher frequency components. In general, this signal represents a constant noise corresponding probably to the characteristic tremor in the legs in a patient with Parkinson's disease. Additionally, the Freeze index was also obtained and plotted on the same figure, which compared to Figure 5 is more unstable in time, oscillating between the minimum and maximum values of 2.05 and 31.85. For the subject shown, an episode of freezing of gait occurred when the FI has a value 31.85, this value could be found on Table 1 and Figure 6. The difference between the application of a fixed window (Figure 4) and a mobile one (Figure 6) can be observed.

5. Conclusions

While using the wearable device developed in this research it is possible to acquire gait signals wirelessly and with batteries without the necessity of using fixed voltage source. The limitations found were related to having a constant sampling frequency which is important in the frequency analysis of the signals used to determine Freeze index. The database recorded with the device provides a primary view of the behavior of gait signals in healthy subjects for normal gait and for the simulated Parkinsonian gait reflecting a match compared to information found in the literature. However, it is necessary to

expand the database with real subjects to determine Freeze Index thresholds that allow predicting a FOG episode more accurately.

The Freeze Indexes obtained from the gait signals from healthy subjects that simulated parkinsonian gait were shown according to expected: compared to normal gait indexes, those for parkinsonian gait were much higher.

According to these findings, with more experimentation and data processing the device could be implemented in Parkinson's patients in order to help this population and the caregivers.

Acknowledgments

This Project was supported partially by the Development of Research Committee (CODI, by its initials in Spanish) of the University of Antioquia.

References

- [1] Elespectador.com, "En Colombia hay 230 mil pacientes con Parkinson", 2011. [Online]. Available: <https://www.elespectador.com/content/en-colombia-hay-230-mil-pacientes-con-parkinson>
- [2] M. Bachlin et al., "Potentials of Enhanced Context Awareness in Wearable Assistants for Parkinson's Disease Patients with the Freezing of Gait Syndrome", International Symposium on Wearable Computers, 2009, pp. 123–130. <https://doi.org/10.1109/ISWC.2009.14>
- [3] A. Amini Maghsoud Bigy, K. Banitsas, A. Badii, and J. Cosmas, "Recognition of postures and Freezing of Gait in Parkinson's disease patients using Microsoft Kinect sensor", 7th International IEEE/EMBS Conference on Neural Engineering (NER), 2015, pp. 731–734. <https://doi.org/10.1109/NER.2015.7146727>
- [4] B. R. Bloem, J. M. Hausdorff, J. E. Visser, and N. Giladi, "Falls and freezing of Gait in Parkinson's disease: A review of two interconnected, episodic phenomena", *Movement Disorders*, vol. 19, no. 8. 2004, pp. 871–884. <https://doi.org/10.1002/mds.20115>
- [5] P. Lamberti et al., "Freezing gait in parkinson's disease", *Eur. Neurol.*, vol. 38, no. 4, 1997, pp. 297–301. <https://doi.org/10.1159/000113398>

- [6] S. T. Moore, H. G. MacDougall, and W. G. Ondo, “Ambulatory monitoring of freezing of gait in Parkinson’s disease”, *J. Neurosci. Methods*, vol. 167, no. 2, 2008, pp. 340–348. <https://doi.org/10.1016/j.jneumeth.2007.08.023>
- [7] E. E. Tripoliti et al., “Automatic detection of freezing of gait events in patients with Parkinson’s disease”, *Comput. Methods Programs Biomed.*, vol. 110, no. 1, 2013, pp. 12–26. <https://doi.org/10.1016/j.cmpb.2012.10.016>
- [8] H. Zach et al., “Identifying freezing of gait in Parkinson’s disease during freezing provoking tasks using waist-mounted accelerometry”, *Park. Relat. Disord.*, vol. 21, no. 11, 2015, pp. 1362–1366. <https://doi.org/10.1016/j.parkreldis.2015.09.051>