



Missouri University of Science and Technology
Scholars' Mine

Mathematics and Statistics Faculty Research &
Creative Works

Mathematics and Statistics

01 Jan 1997

Elimination of Supply Harmonics

Stephen L. Clark

Missouri University of Science and Technology, sclark@mst.edu

P. Famouri

W. L. Cooley

Follow this and additional works at: https://scholarsmine.mst.edu/math_stat_facwork

 Part of the [Mathematics Commons](#), and the [Statistics and Probability Commons](#)

Recommended Citation

S. L. Clark et al., "Elimination of Supply Harmonics," *IEEE Industry Applications Magazine*, Institute of Electrical and Electronics Engineers (IEEE), Jan 1997.

The definitive version is available at <https://doi.org/10.1109/2943.579138>

This Article - Journal is brought to you for free and open access by Scholars' Mine. It has been accepted for inclusion in Mathematics and Statistics Faculty Research & Creative Works by an authorized administrator of Scholars' Mine. This work is protected by U. S. Copyright Law. Unauthorized use including reproduction for redistribution requires the permission of the copyright holder. For more information, please contact scholarsmine@mst.edu.

Elimination of Supply Harmonics

S.L. Clark, P. Famouri, and W.L. Cooley

The price of the extensive use of power electronic devices is becoming clear: increasing harmonic "pollution." The same switching conduct that allows active devices to perform with a proficiency that belies their size is responsible for supply harmonics generation. Since there is no viable alternative for these non-linear devices in electrical engineering, the subject of supply harmonics presently has broad interest. According to the Electric Power Research Institute (EPRI), presently "35-40% of all electric power flows through electronic devices. This is supposed to increase to 60% by the year 2000" [1]. Without a doubt, the source of potentially harmful harmonics is growing.

Supply harmonics are also caused by transformers, motors, and rectifiers; they have been detected as early as the 1920s and '30s [2]. A system can function adequately, however, in the presence of limited amounts of harmonics, and in the past amounts injected into systems were generally considered insignificant. Isolated problems caused by large industrial users were handled by locally reducing the harmonics to a more tolerable level. A method such as phase multiplication could be used to reduce harmonics at a site with a balanced load [3]. Today, however, increased industrial and consumer dependence on equipment with non-linear components is aggravating the situation. We are, in fact, not only in-

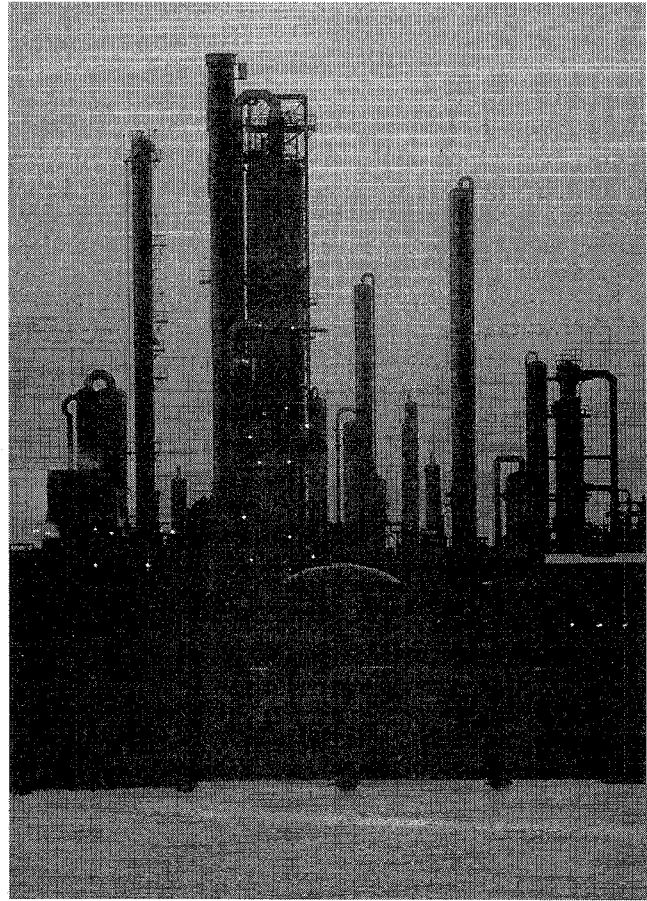

©PhotoDisc

creasing the amounts of harmonics put into systems, but we are using equipment that is more susceptible to damage by the harmonics.

The greater amount of harmonics being introduced into power distribution systems is of concern to both power consumers and power companies. Power companies, of course, do not want to be put in a position of responsibility for problems caused by harmonics, and likewise, consumers would prefer to not deal with the expense and inconvenience of interference or damaged equipment. Also, the cost of power losses due to harmonics is not a trivial factor [2]. In some cases, industrial consumers found to be responsible for the injection of an inordinate amount of harmonics are being required to take steps to reduce the problem, since harmonic current, seeking the low impedance of harmonic filters, has been known to travel through distribution systems and create problems at industrial sites without their own source of harmonics. An industrial site within

This article appeared in its original form at the IAS 29th Annual Meeting in Denver, Colo., in October 1994. The authors are with the Department of Electrical & Computer Engineering, West Virginia University, Morgantown, WV 26506-6104. Clark is an IEEE Member; Famouri is an IAS Member; Cooley is an IAS Member and an IEEE Senior Member.

100-200 miles of a source of harmonics could be at risk [3].

First, a brief look will be taken at background information which describes harmonic sources, effects, and characteristics. Then the evolution of the harmonics elimination approaches of current compensation and active filtering will be discussed to give some insight into the directions that research is taking.

Background

Sources of Harmonics

As stated above, harmonics are caused by any non-linear device. Power converters, specifically, are responsible for a disproportionate amount of the harmonics troubling power systems today [5]. Converters are used in adjustable speed drives, power supplies, and UPS systems; the term converter can refer to rectifiers, inverters, and cycloconverters. Arc furnaces are another significant source of harmonics.

Effects of Harmonics

Harmonics in power systems can be the source of a variety of unwelcome effects. For example, harmonics can cause signal interference, overvoltages, data loss, and circuit breaker failure, as well as equipment heating, malfunction, and damage.

Harmonics have been known to be responsible for noise on both telephone and data transmission lines, and they can induce malfunction of relays and meters. Harmonic current components that are coincidentally similar to the carrier signals in a particular system can interfere with the use of the carrier signals [3]. Electronic devices are particularly vulnerable; huge increases in computer data loss, up to 10 times the previous amount of data loss, were recorded after one installation of harmonics-producing equipment [6].

Harmonics can cause excessive heating in transformers and capacitors, resulting in shortened life or failure; guidelines for the use of these components in harmonic conditions are given in ANSI/IEEE Std. 18-1980 and IEEE Std. C57.110, respectively. Rotor heating and pulsating output torque caused by harmonics can result in excessive motor heating and inefficiency.

Generally, the total harmonic distortion in an industrial setting should not exceed 5% [7]. Com-

prehensive guidelines are given in the IEEE Recommended Practices and Requirements for Harmonic Control in Electrical Power Systems Std. 519-1992.

Harmonics not only contribute to general system power loss, but the reductions in ac motor efficiency and product quality, and the increases in maintenance, required system investment, required reactive power, and losses in transformers, capacitors, and conductors can be costly.

Effects of Harmonic Resonance

Power systems have natural frequencies which are related to the capacitance of power factor correction capacitor banks; unfortunately, these natural frequencies are often in the range of the harmonics caused by non-linear devices. Matching of these frequencies, or resonance, may exacerbate a situation where a small amount of harmonic current is already present. In resonant conditions, the oscillations of the current waveform are reinforced and amplified; therefore, even small amounts of harmonic current can increase such that the magnitudes of the harmonic orders may near the fundamental in size. Large overvoltages can be the result. Resonant conditions cause general system instability, decreased productivity when converters are tripped due to overvoltages, and have been blamed for fires and equipment damage [8].

Harmonic Magnitudes and Orders Produced

The magnitudes and orders of harmonic components present depend on a variety of factors, including the harmonic source, the power level of the system, and whether or not the system is at a point of resonance.

At high power levels, harmonic currents and voltages of large magnitude may be produced. These harmonics, even if produced by a single piece of equipment, can vary during normal operation. For example, an arc furnace was observed to produce harmonic voltages that varied between 8%, 6%, and 2.5% of the fundamental voltage during beginning of meltdown, end of meltdown, and refining [5]. Harmonic currents of 5.5% to 140% have been seen in computer power systems [9].

The harmonic current component orders produced by pulse-converters are related to the pulse number. Fourier analysis of the source current waveform shows that the harmonic components are of the order [10]:

$$b = k \cdot p \pm 1 \quad (1)$$

where

k = integer from Fourier analysis

p = converter pulse number

Therefore, a 6-pulse converter produces odd harmonics not divisible by three. The range of the harmonic orders produced changes, i.e., starts at a

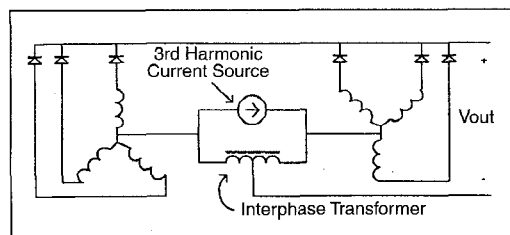

Fig. 1. Duplex 6-phase rectifier with third harmonic current generator.

higher numbered order, as the pulse number is increased.

Non-linear loads can also produce "triplens," which are multiples of the third harmonic. These may warrant special attention, since they add in the neutral conductor, and may possibly even exceed the phase current in magnitude. Arc furnaces produce triplens during unbalanced conditions which occur during electrode arcing; further, other odd harmonics that occur even in balanced conditions could increase in magnitude during arcing. Arc furnaces typically produce a third-ordered harmonic with a magnitude of 20% of the fundamental; magnitudes of up to 29% are a worst-case estimate [4].

Methods of Dealing with Harmonics

There are several options available to solve or alleviate problems introduced by harmonics, including derating, passive filters, and harmonic filtering or current compensation methods which use active devices.

As an alternative to reducing harmonics, it has been suggested that some of their potentially damaging effects be merely avoided by, for example, derating transformers and oversizing neutrals [9]. This could be an adequate solution in some cases, but again, since system changes can cause changes in the amounts of harmonics in the system, the exact amount of derating or oversizing necessary could be difficult to predict. Also, this option does not prevent harmonics from entering the supply system.

Passive filters can prevent harmonics from entering a supply system, and are also useful in increasing power factor. However, these filters are designed to filter specific harmonic components; they are not adaptable to successfully filter varying harmonics. Cycloconverters can cause particular difficulties since the frequencies of harmonics produced will vary with operation. Likewise, any system experiencing supply or load changes can also expect a change in the harmonics produced. Further, passive filters must be carefully sized. Undesirably large bus voltages can result from using an oversized filter, and an undersized filter can become overloaded. Size can be difficult to gauge, considering that harmonic current can be drawn from other areas of a distribution system. Finally, other complications, such as those related to resonance, are possible. Interaction between the capacitance in passive filters and system impedance can, in fact, result in a system resonance condition. This resonance condition can persist even with the filter tuned slightly below the system resonant frequency [11]. Also, changes in the distribution system can cause the resonant point itself to change. All of these points can be drawbacks to the passive filter option.

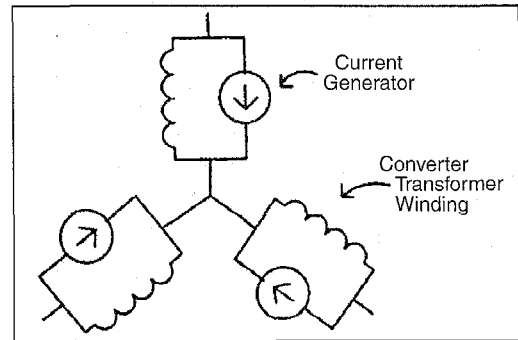

Fig. 2. Separate current generators used with each winding.

The shortcomings of the options of derating and passive filters point to the fact that these techniques may not be optimal methods of dealing with a harmonics problem. The use of active filters or harmonic current compensation circuitry to eliminate harmonics before they enter a supply system is still generally thought to be costly and impractical. But technological improvements and considerable research are combining to make this approach feasible.

Active Filtering and Current Compensation

Injection of a Third Harmonic Current

One of the pioneering attempts at reducing harmonics generation, as opposed to the use of conventional passive filters to remove harmonics, was made by B. Bird, et al. [12]. After recognizing that the harmonic currents formed by a pulse-converter are related to its pulse number (number of equally spaced commutations), two means of changing this relationship were seen: spacing commutations unequally, which can result in the introduction of even order harmonics, and thus not provide a reasonable solution, or changing the current waveform. Their design proposed changing the current waveform by injecting a third harmonic current, displaced in phase, into the converter itself; this would have a partial neutralizing effect on the harmonics.

Fig. 1 shows the experimental circuit used, which consisted of a duplex 6-phase rectifier, or "double-star" rectifier. The configuration of this rectifier lends itself to current injection, since it includes an interphase transformer (a transformer used to link more than one rectifier). A 3-phase current generator was connected in parallel with the interphase transformer; the frequency of the sinusoidal current injected by this generator was three times that of the 50 Hz supply frequency, or the third harmonic.

The harmonic analysis of the rectifier primary phase current, Equation (2), was used to mathematically show the expected effect of an injected current:

$$i(\theta) = \frac{2\sqrt{3}}{\pi} b \left[\begin{aligned} &\left(1 + \frac{1}{8} \frac{y}{b}\right) \sin \theta - \frac{\pi}{3\sqrt{3}} \frac{y}{b} \sin 3\theta \\ &- \frac{1}{5} \left(1 - \frac{25}{16} \frac{y}{b}\right) \sin 5\theta - \frac{1}{7} \left(1 - \frac{49}{40} \frac{y}{b}\right) \sin 7\theta \\ &\dots - \frac{1}{n} \left(1 - \frac{n^2}{n^2 - 9} \frac{y}{b}\right) \sin n\theta \end{aligned} \right] \quad (2)$$

where:

y = peak amplitude of the third harmonic injected current

b = amplitude of the secondary current before injection

In Equation (2), the ratio $\frac{y}{b}$ is proportional to the magnitude of the injected current, and inversely proportional to the output current; this ratio can be varied from zero to one. As the ratio is increased, the harmonic order to be eliminated also increases, therefore, any single harmonic can be chosen to be eliminated with an appropriate selection of $\frac{y}{b}$. Also, most of the remaining harmonics are reduced. The effects of current injection are not entirely favorable, however, as it can also be seen from the equation that any value of $\frac{y}{b}$, other than zero, will cause an increase in the third harmonic.

Bird's experimental results were in agreement with their theoretical expectations. The fifth harmonic neared zero when the ratio y/b was set equal to 0.6; a ratio of 0.64 is the value determined by Equation (2). Overall, their results proved the method to be very effective in eliminating one harmonic order of choice and reducing the other orders in amounts between approximately 25% and nearly 100%. Their work mentions the factors of versatility and cost: adaptability to other converters allowing current injection gives some versatility; however, the increase in the third harmonic mentioned previously could require a transformer derating, thereby adding to system costs. Also, since power losses increase with an increase in the y/h ratio, attempts at eliminating higher-order harmonics could decrease the system efficiency.

Refinement of Harmonic Current Injection

Bird's group made significant breakthroughs in the area of harmonics elimination; the major drawback was that it was impossible to fully eliminate more than one harmonic. Ametani sought to expand the usefulness of current injection by proposing a technique to eliminate multiple harmonics

[13, 14]. According to this theory, an active control circuit could be used to precisely shape the injected current. Ideally, this current would contain harmonic components of opposing phase. Thus, the harmonics would neutralize; only the fundamental would remain.

Ametani's work discusses a design that could be adaptable to a broader range of converters; separate current sources are connected in parallel with each phase of either star or delta connected windings as shown in Fig. 2, rather than in parallel with an interphase transformer.

Despite the promising theoretical concept, Ametani was not successful in producing a practical control circuit capable of creating a precise current. As in Bird's experiments, a sine wave was injected, and similar results were found. However, Ametani interpreted the results differently; it was concluded that 0.5 was the optimal value for the ratio, since this reduced the total harmonic distortion, although not completely eliminating any single component.

Although some of what had been theoretically proposed could not be verified experimentally, Ametani was successful in using injection currents of various frequencies. His results showed that regardless of the frequency of the injected current, harmonics of frequencies higher than that of the injected current were reduced, while those lower were increased. Although a ninth harmonic injected current would not be able to eliminate the fifth or seventh harmonics, the capability of using a higher harmonic injected current could indeed be valuable with a higher pulse numbered converter, as this type of converter would not produce harmonics in the lower range. For example, referring again to Equation (1), the range of harmonics produced by a 12-pulse converter would begin with the 11th order.

Magnetic Flux Compensation

In a related approach, Sasaki and Machida theorized that harmonics could be eliminated by using the principle of magnetic flux compensation [15]. This, in an ideal sense, is the use of current to produce a flux to counteract the flux produced by the harmonics.

The design of a control circuit capable of creating the required current was proposed. This design involved filtering the fundamental component of the waveform, then amplifying the balance, consisting of the higher harmonic components. Then, injection of this current into the compensating winding would create a flux that would, in turn, neutralize the flux created by the harmonic current components themselves; each created harmonic current component would thus be used to neutralize the original counterpart. Once again, theoretically, any number of harmonics could be eliminated directly.

The current that would be required to eliminate waveform distortion caused by harmonics was calculated mathematically, but again, a practical control circuit was not realized; this prevented experimentation with an actual circuit model. Use of the principle of magnetic flux compensation would require a control circuit capable of accurately differentiating between the fundamental and other harmonics, since its purpose would be to generate the harmonics other than the fundamental. It was pointed out in this work that the rather high cost of the high-power amplifier and the circuitry necessary to protect it from high voltages were further drawbacks to the method.

Switching to Improve Current Drawn

Supplying inverter reactive power needs was the primary focus of some attempts to improve inverter systems, but at the same time, efforts were made to reduce the problem of harmonics. Passive filters are a common method of removing harmonics, and their capacitance is often depended upon to improve the power factor, but Epstein et al. recognized that this was especially inadequate in variable load conditions, since harmonic orders may vary with the loads. This led to their development of a switching system to be used as a means to provide the compensating current necessary to remove harmonics, and thereby improve the supply current waveform [16].

The switching system, which consisted of a simple bridge circuit, used thyristors switched in pairs to produce a two-level current waveform, which was then both pulse-width and frequency modulated. The timing of the switching needed was determined by a control unit which monitored the instantaneous load voltage and current.

Working with similar ideas, Van Wyk et al. incorporated the use of active components in control circuitry to compute and generate the current required to improve the supply current waveform [17]. Improved force-commutated PWM inverters with control circuits made it possible to accomplish this. The control circuit received information on the supply voltage, the actual converter input voltage, and the actual converter currents on both the ac and dc sides, and the thyristor pairs were switched accordingly. The difference between the calculated current and the measured compensating current was continuously monitored.

It was believed that these results would be valuable not only for power factor improvement, but also for the elimination of harmonics and unbalanced conditions, since theoretically any current could be provided to eliminate any distortion.

Active Filters with Practical Control

Also while working on the problem of reactive power compensation, Akagi et al. researched the possibility of a compensator that could also elimi-

nate harmonic current [18]. Their innovative concept of "instantaneous imaginary power," as opposed to reactive power, allowed it to be shown mathematically that reactive power compensation could eliminate some harmonic components of the input current, specifically those of frequency:

$$f = f_{in} \pm 6 f_{out} \quad (3)$$

The experimental circuit was composed of their compensator, with a bridge converter as the load. The control circuit, designed to instantly calculate the compensating current, used analog circuitry. The extent of the harmonics reduction and the overall performance quality was not extensively discussed.

Further utilizing the concept of instantaneous reactive power, Akagi et al. worked to improve the active filter control method [19]. It was recognized that the ideal current necessary to remove harmonics could be mathematically calculated; it was intended to produce circuitry that could effectively create this ideal current.

The second test circuit was constructed using four series-connected PWM converters, analog circuitry for current compensation, and a bridge converter for the harmonics-producing load. Using phase voltage and load current measurements, the instantaneous real and imaginary load powers were calculated; this information was then used in the calculation of the compensating current.

In the discussion of the results, it was pointed out that, while the method was successful in eliminating harmonics, the costs of its complex circuitry might prohibit its general use. However, the cost could possibly be justified in the case where variable harmonics must be eliminated, since conventional passive filtering methods cannot compete in this area.

Passive and Active Filter Combinations

Further advances in the area of harmonics reduction continued to be made by Peng, Akagi, and Nabae [20], who next researched the effects of combining passive and active filters, intending to combine their better points and reduce the shortcomings of either alone. This technique differs from the previous method in that it does not use the active filter for harmonic current compensation, but rather to improve the characteristics of the passive filter. The active filter both deters harmonic current before it reaches the passive filter and prevents a parallel resonance situation between the passive filter and the source impedance.

A test circuit used a series active filter connected through a current transformer, a parallel connected passive filter, and a three-phase six-pulse converter for the harmonics-producing load. The active filter was controlled to offer a small impedance to the fundamental and a large impedance

to harmonic components. Tests were performed on both the passive filter alone and the combination circuit; the advantage given by the addition of the active filter was clearly shown in the results. Tests on the passive filter alone demonstrated its typical shortcomings: some harmonic current remained and, in resonant conditions, system destabilizing distortion was possible. On the other hand, the addition of the active filter provided a near-sinusoidal output and ruled out the possibility of a resonant condition.

As this method used the active filter to perform different tasks than the usual, a smaller rated filter was required. As a result, a smaller power loss was caused by the addition of this active filter.

Active filters and current compensation methods are a possible means of combating the growing problem of harmonics troubling power systems. The development of practical ways to utilize these methods has been an arduous process, and has already spanned well over twenty years. But, many research teams continue to refine techniques, as problems remain to be solved.

The factor of cost efficiency has been and continues to be a major obstacle in realizing these methods; thus, it has proven difficult to move past the experimental stage. But, because additions of conventional passive filters can have undesirable ramifications due to system interaction, and because passive filters also are not capable of adequately solving the problem of varying harmonics components, the search for a "practical" solution continues.

Taking the concept of harmonics elimination at the source even a step further, many are of the opinion that perhaps the best solution would be to solve the problem even more directly, by incorporating harmonics compensation circuitry into the harmonics producing equipment itself. This might be considered a step toward the ideal: equipment that does not produce harmonics. New converter-system designs will feature power quality improvement. Still, others do not believe that fitting individual units can be considered to be an economical approach [21].

Either way, the astounding improvements in power electronic technology of the past 10 years, including MOS-controlled thyristors and microprocessor-based control circuitry, will ultimately permit simpler, more efficient and reliable, and less costly active filtering and current compensation system designs. Therefore, the allure of the power electronics harmonics solution, whether unit-incorporated or system-based, will only increase.

References

- [1] L. Lamarre, "Problems With Power Quality," *EPRI Journal*, 16(5), pp. 14-23, July/Aug. 1991.
- [2] IEEE Working Group on Power Systems Harmonics, "Power Systems Harmonics: An Overview," *IEEE Trans. Power App. Syst.*, PAS-102(8), pp. 2455-2460, Aug. 1983.
- [3] D.E. Steeper and R.P. Stratford, "Reactive Compensation and Harmonic Suppression for Industrial Power Systems Using Thyristor Converters," *IEEE Trans. Industry Applications*, IA-12(3), pp. 232-254, May/June 1976.
- [4] S.R. Mendis and D.A. Gonzalez, "Harmonic and Transient Overvoltage Analyses in Arc Furnace Power Systems," *IEEE Trans. Industry Applications*, 28(2), pp. 336-342, Mar./Apr. 1992.
- [5] D.A. Gonzalez, J.C. McCall, "Design of Filters to Reduce Harmonic Distortion in Industrial Power Systems," *IEEE Trans. Industry Applications*, IA-23(3), pp. 504-511, May/June 1987.
- [6] K.H. Sueker, S.D. Hummel, and R.D. Argent, "Power Factor Correction and Harmonic Mitigation in a Thyristor Controlled Glass Melter," *IEEE Trans. Industry Applications*, 25(6), pp. 972-975, Nov./Dec. 1989.
- [7] P.W. Hammond, "A Harmonic Filter Installation to Reduce Voltage Distortion from Static Power Converters," *IEEE Trans. Industry Applications*, 24(1), pp. 53-58, Jan./Feb. 1988.
- [8] G. Lemieux, "Power System Harmonic Resonance—A Documented Case," *IEEE Trans. Industry Applications*, 26(3), pp. 483-485, May/June 1990.
- [9] T.M. Gruz, "A Survey of Neutral Currents in Three-Phase Computer Power Systems," *IEEE Trans. Industry Applications*, 26(4), pp. 719-725, July/Aug. 1990.
- [10] R.L. Smith and R.P. Stratford, "Power System Harmonics Effects from Adjustable-Speed Drives," *IEEE Trans. Industry Applications*, IA-20(4), pp. 973-977, July/Aug. 1984.
- [11] D.E. Rice, "Adjustable Speed Drive and Power Rectifier Harmonics—Their Effect on Power Systems Components," *IEEE Trans. Industry Applications*, IA-22(1), pp. 161-177, Jan./Feb. 1986.
- [12] B.M. Bird, J.F. Marsh, and P.R. McLellan, "Harmonic Reduction in Multiplex Converters by Triple-frequency Current Injection," *Proc. IEE*, 116(10), pp. 1730-1734, Oct. 1969.
- [13] A. Ametani, "Generalized Method of Harmonic Reduction in ac-dc Converters by Harmonic Current Injection," *Proc. IEE*, 119, pp. 857-864, July 1972.
- [14] A. Ametani, "Harmonic Reduction in Thyristor Converters by Harmonic Current Injection," *IEEE Trans. Power App. Syst.*, PAS-95(2), pp. 441-449, Mar./Apr. 1976.
- [15] H. Sasaki and T. Machida, "A New Method to Eliminate ac Harmonic Currents by Magnetic Flux Compensation—Considerations on Basic Design," *IEEE Trans. Power App. Syst.*, pp. 2009-2019, Feb. 1971.
- [16] E. Epstein, A. Yair, and A. Alexandrovitz, "Analysis of a [16]Reactive Current Source Used to Improve Current Drawn by Static Inverters," *IEEE Trans. Industrial Electronics and Control Instrumentation*, IECI-26(3), pp. 172-177, Aug. 1979.
- [17] J. Van Wyk, D. Marshall, and S. Boshoff, "Simulation and Experimental Study of a Reactively Loaded PWM Converter as a Fast Source of Reactive Power," *IEEE Trans. Industry Applications*, IA-22(6), pp. 1082-1089, Nov./Dec. 1986.
- [18] H. Akagi, Y. Kanazawa, and A. Nabae, "Instantaneous Reactive Power Compensators Comprising Switching Devices without Energy Storage Components," *IEEE Trans. Industry Applications*, IA-20(3), pp. 625-630, May/June 1984.
- [19] H. Akagi, A. Nabae, and S. Atoh, "Control Strategy of Active Power Filters Using Multiple Voltage Source PWM Converters," *IEEE Trans. Industry Applications*, IA-22(3), pp. 460-465, May/June 1986.
- [20] F.Z. Peng, H. Akagi, and A. Nabae, "A New Approach to Harmonic Compensation in Power Systems—A Combined System of Shunt Passive and Series Active Filters," *IEEE Trans. Industry Applications*, 26(6), pp. 983-989, Nov./Dec. 1990.
- [21] R. Sarri, C.K. Duffy, and R.P. Stratford, "Discussion of Update of Practices and Requirements for Harmonic Control in Electric Power Systems," *IEEE Trans. Industry Applications*, 27(2), Mar./Apr. 1991.