



Missouri University of Science and Technology
Scholars' Mine

Mathematics and Statistics Faculty Research &
Creative Works

Mathematics and Statistics

01 Jan 2001

Power Connector

Stephen L. Clark

Missouri University of Science and Technology, sclark@mst.edu

Joseph B. Shuey

Jose L. Ortega

John B. Brown III

Follow this and additional works at: https://scholarsmine.mst.edu/math_stat_facwork

 Part of the [Mathematics Commons](#), and the [Statistics and Probability Commons](#)

Recommended Citation

S. L. Clark et al., "Power Connector," *U.S. Patents*, Jan 2001.

This Patent is brought to you for free and open access by Scholars' Mine. It has been accepted for inclusion in Mathematics and Statistics Faculty Research & Creative Works by an authorized administrator of Scholars' Mine. This work is protected by U. S. Copyright Law. Unauthorized use including reproduction for redistribution requires the permission of the copyright holder. For more information, please contact scholarsmine@mst.edu.



US006319075B1

(12) **United States Patent**
Clark et al.

(10) **Patent No.:** **US 6,319,075 B1**
(45) **Date of Patent:** **Nov. 20, 2001**

(54) **POWER CONNECTOR**

(75) Inventors: **Stephen L. Clark**, Dillsburg; **Joseph B. Shuey**; **Jose L. Ortega**, both of Camp Hill; **John B. Brown, III**, Mechanicsburg, all of PA (US)

(73) Assignee: **FCI Americas Technology, Inc.**, Reno, NV (US)

(*) Notice: Subject to any disclaimer, the term of this patent is extended or adjusted under 35 U.S.C. 154(b) by 0 days.

(21) Appl. No.: **09/160,900**

(22) Filed: **Sep. 25, 1998**

Related U.S. Application Data

(60) Provisional application No. 60/082,091, filed on Apr. 17, 1998.

(51) **Int. Cl.**⁷ **H01R 13/05**

(52) **U.S. Cl.** **439/825**; 439/65; 439/78; 439/947.2

(58) **Field of Search** 439/79, 692, 825-827, 439/947, 947.2

(56) **References Cited**

U.S. PATENT DOCUMENTS

4,626,637	12/1986	Olsson et al.	200/284
4,685,886	8/1987	Denlinger et al.	439/55
4,790,763	* 12/1988	Weber et al.	439/65
4,790,764	* 12/1988	Kawaguchi et al.	439/78
4,875,865	10/1989	Demler et al.	439/101
4,881,905	11/1989	Demler et al.	439/79
5,139,426	8/1992	Barkus et al.	439/65
5,158,471	10/1992	Fedder et al.	439/80
5,281,168	1/1994	McCleerey et al.	439/510
5,295,843	3/1994	Davis et al.	439/108

5,362,249	11/1994	Carter	439/357
5,376,012	12/1994	Clark et al.	439/80
5,403,206	4/1995	McNamara et al.	439/608
5,549,480	8/1996	Cheng	439/79
5,582,519	* 12/1996	Buchter	439/101
5,618,187	* 4/1997	Goto	439/79
5,643,013	7/1997	Weidler et al.	439/660
5,667,392	9/1997	Kocher et al.	439/79
5,785,557	7/1998	Davis	439/660
5,904,594	5/1999	Longueville et al.	439/608

* cited by examiner

Primary Examiner—Hien Vu

(74) *Attorney, Agent, or Firm*—M. Richard Page; Steven M. Reiss

(57) **ABSTRACT**

A pair of mating connectors includes a receptacle having an insulative housing and at least one conductive receptacle contact with a pair of spaced walls forming a plug contact receiving space. The plug connector has an insulative housing and at least one conductive contact having a pair of spaced walls which converge to form a projection engageable in the plug receiving space of the receptacle contact. In each case, the spaced walls are joined by a bridging structure that unites the walls. The plug and receptacle contacts are retained in the respective housings by engagement of opposed lateral edge portions of the contacts with the housings in a manner to enhance heat dissipation by convection by maintaining substantial portions of the contacts spaced from the housing walls and from each other. The bridging structure may include a retention element for engaging respective connector housings to retain the contact in the housings. The open structure of both the receptacle and plug contacts enhances heat dissipation and allows flexibility in achieving desired contact normal forces. The contact construction is especially useful for electronic power connectors.

11 Claims, 22 Drawing Sheets

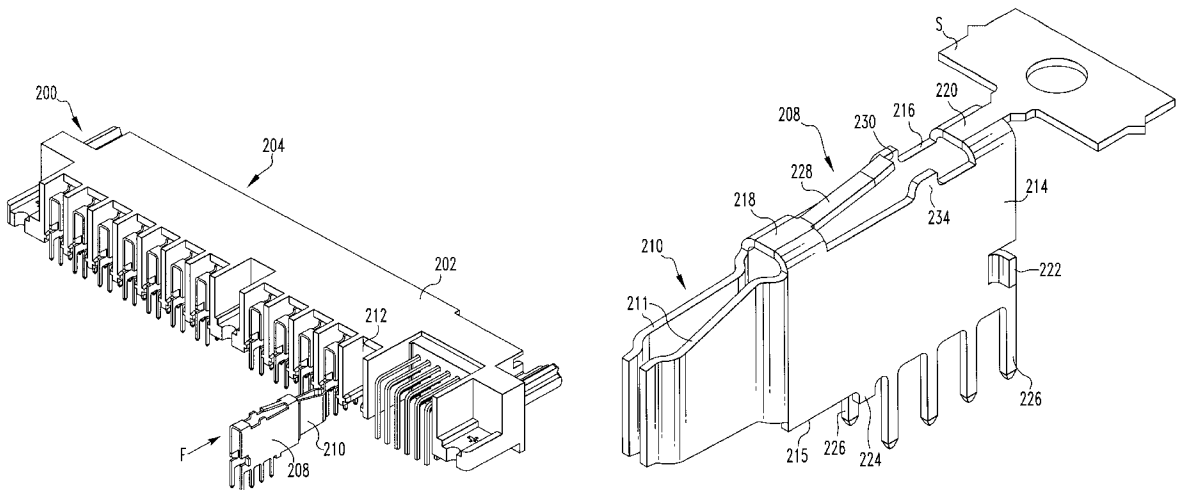

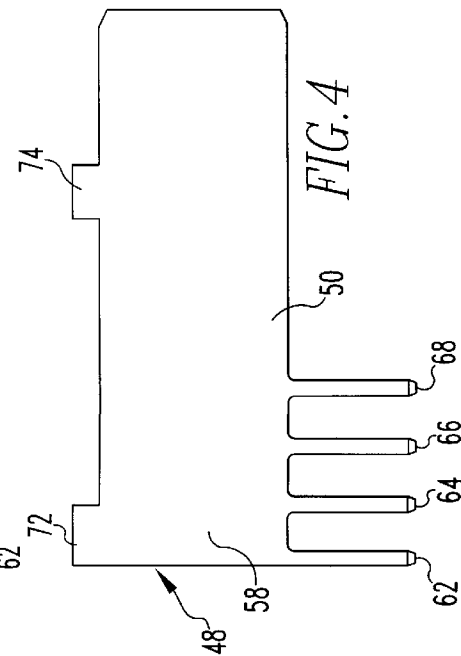
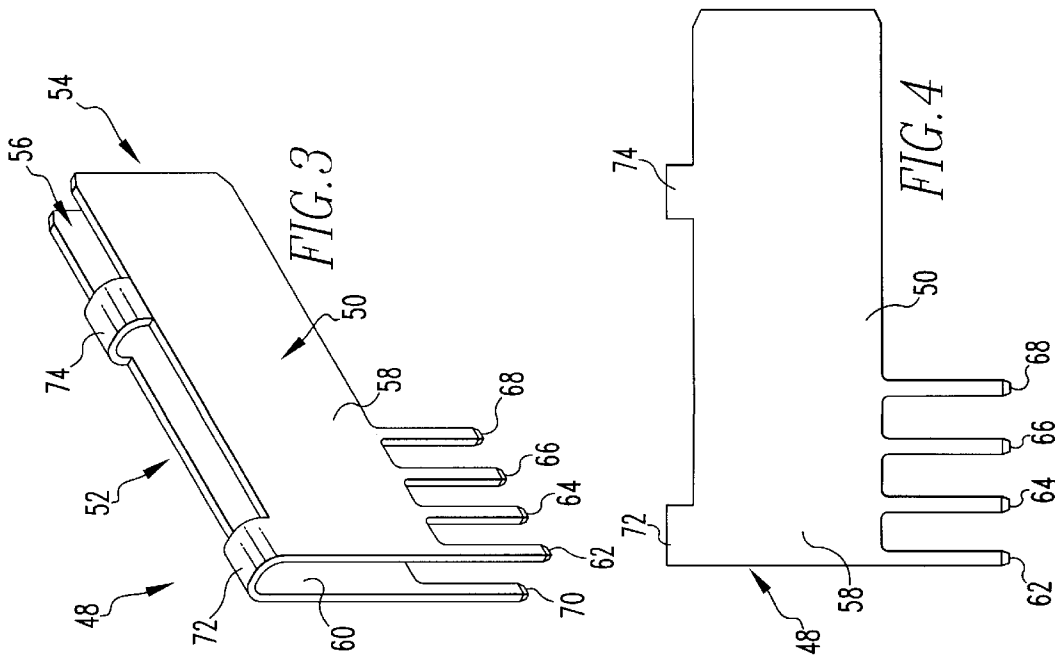
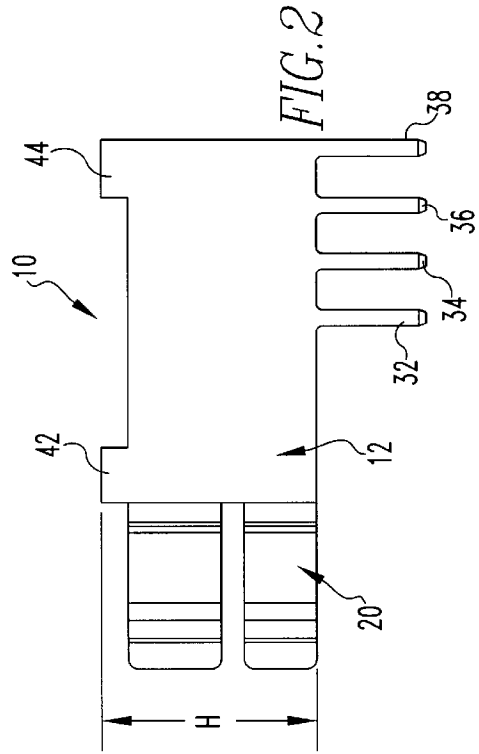
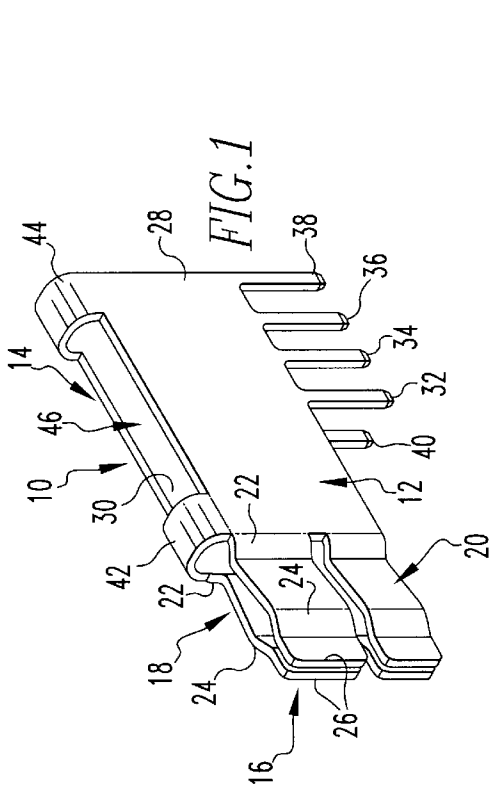

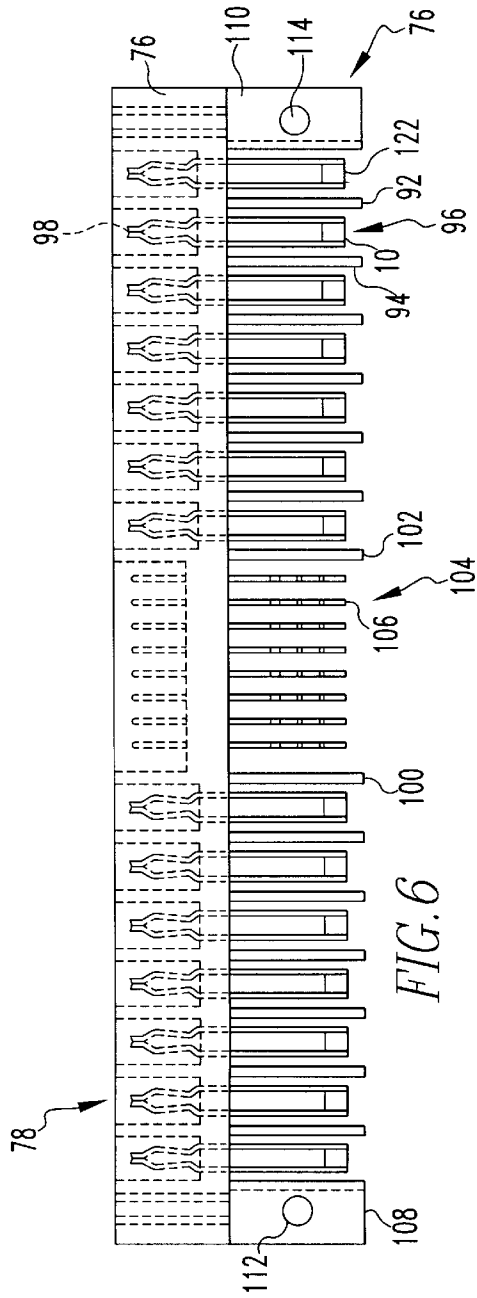
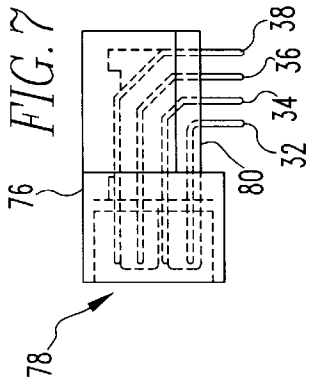
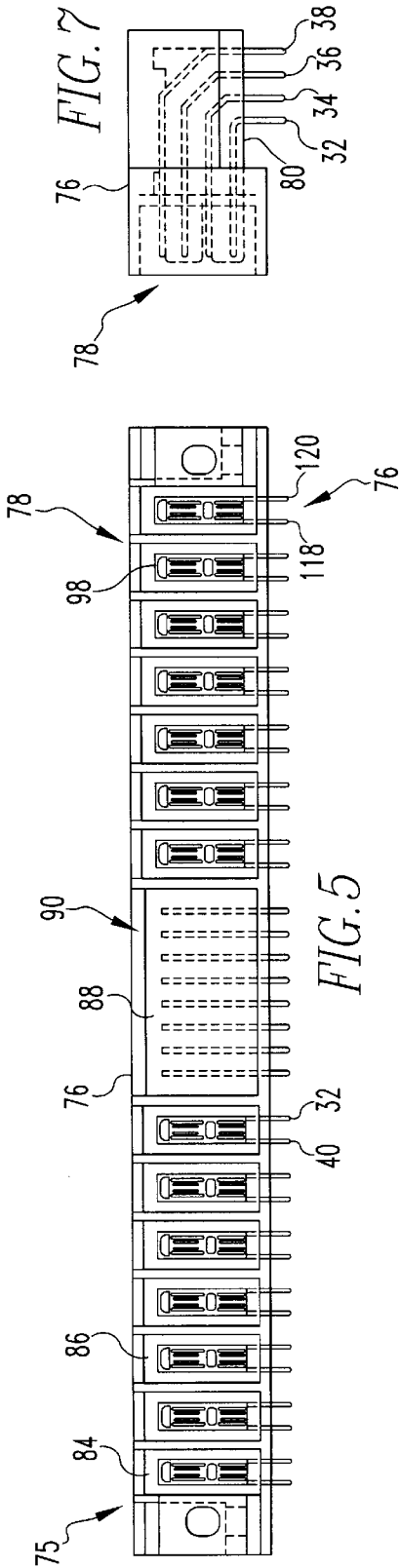

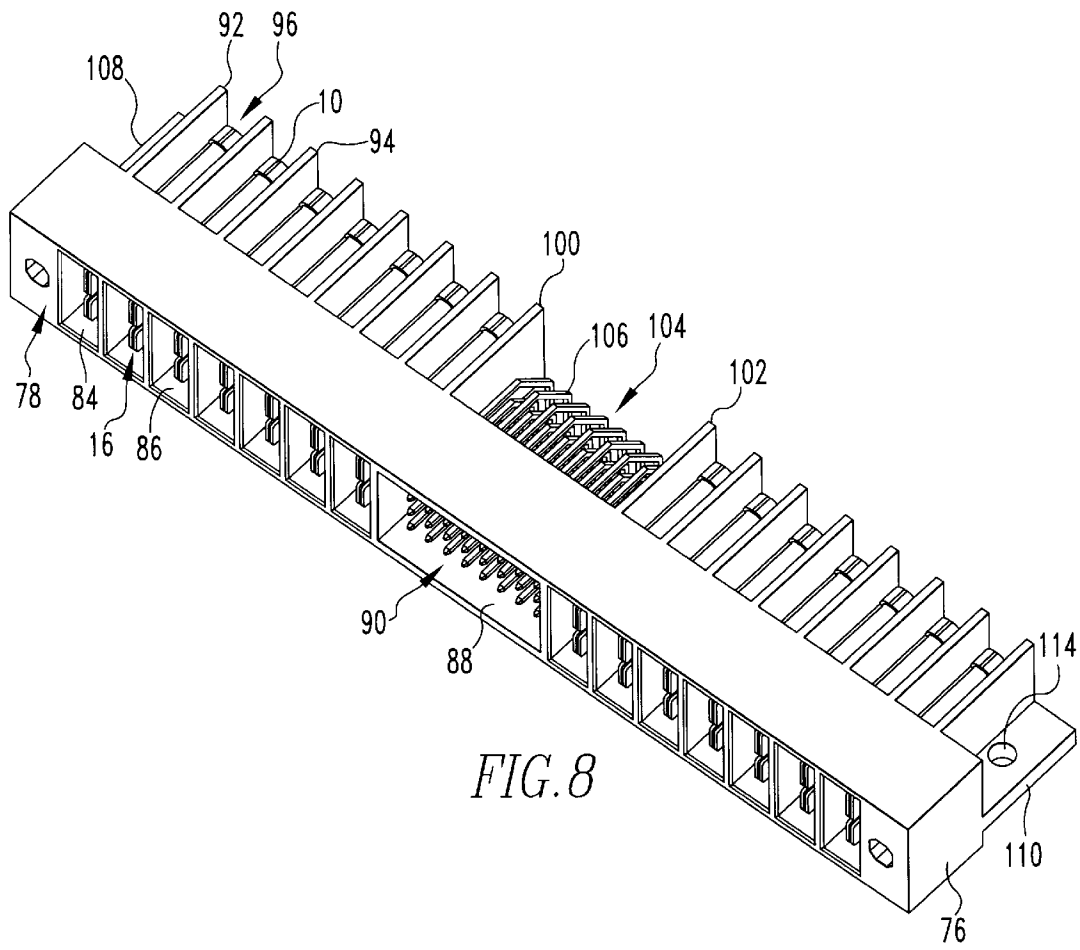

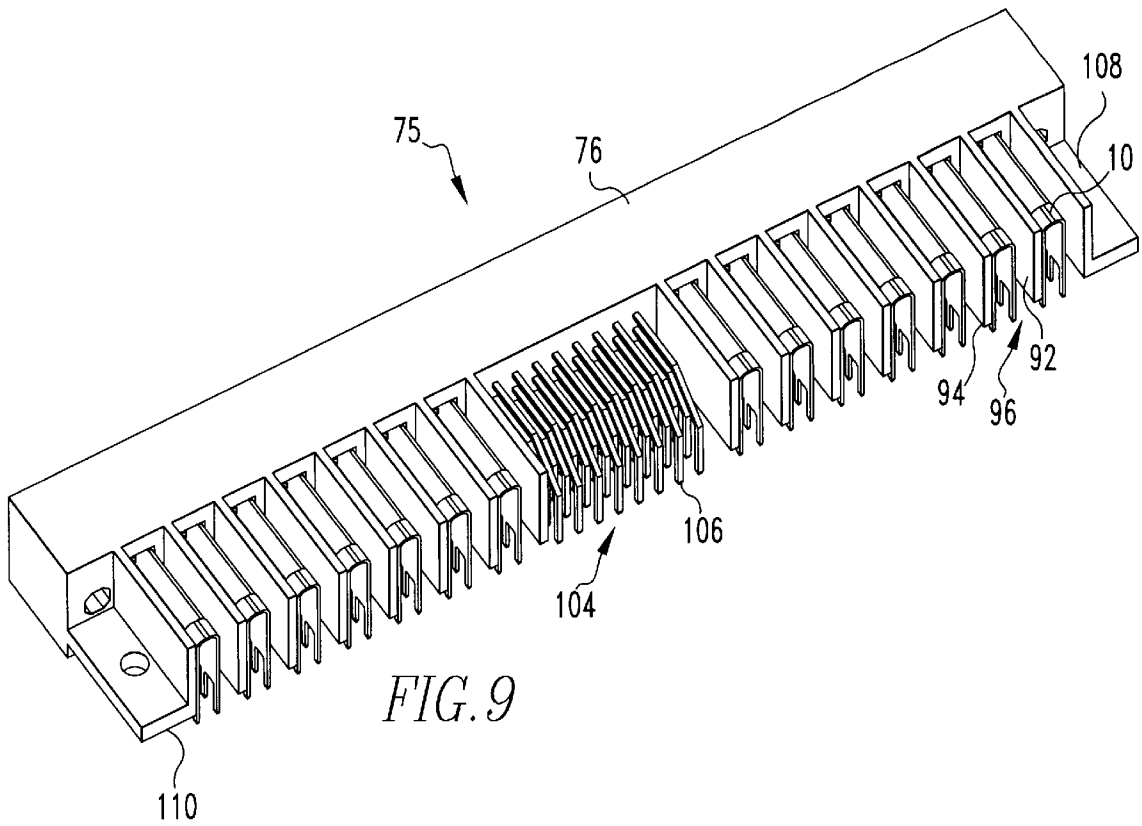

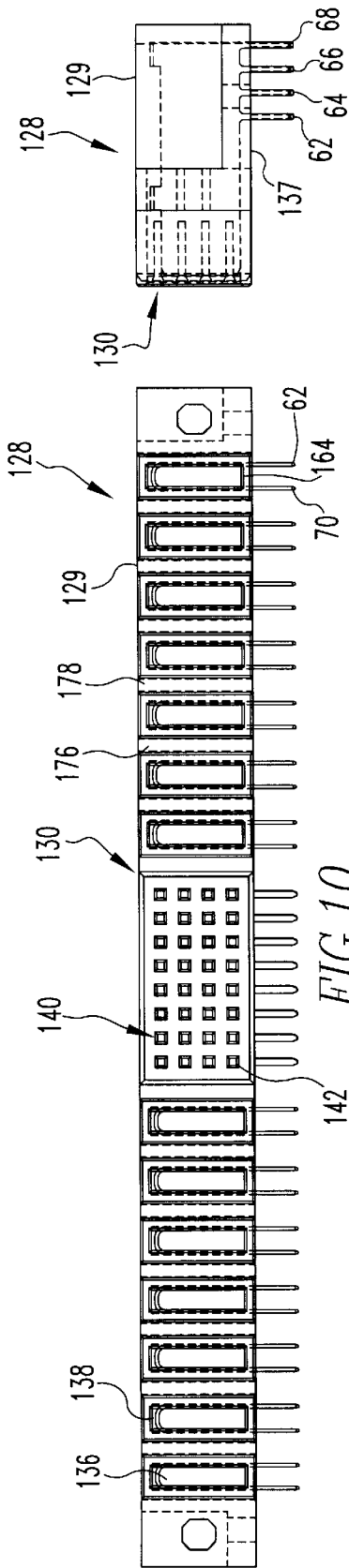

FIG. 10

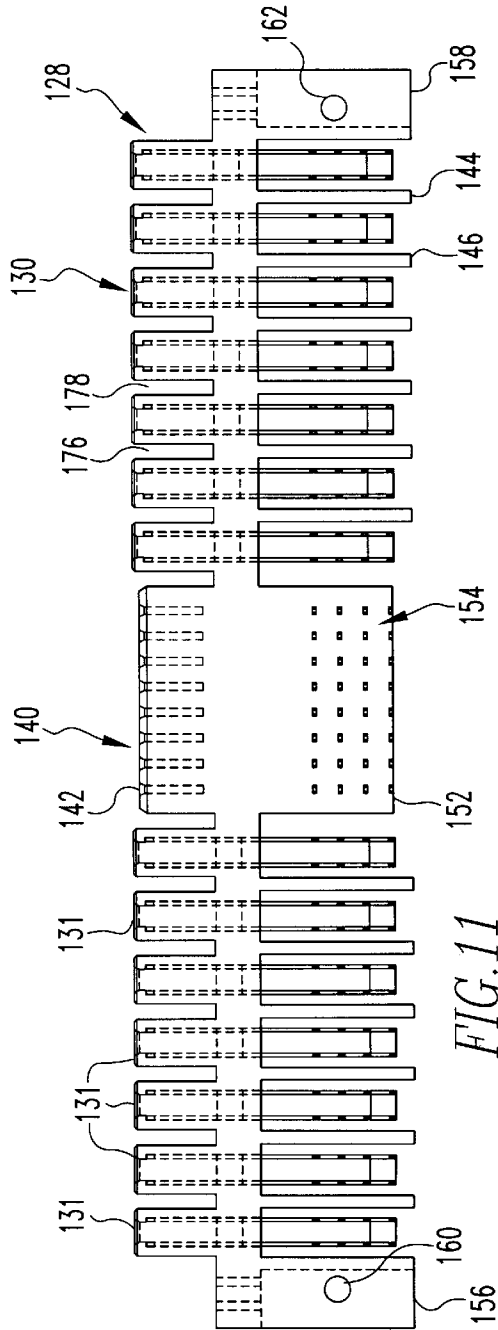

FIG. 11

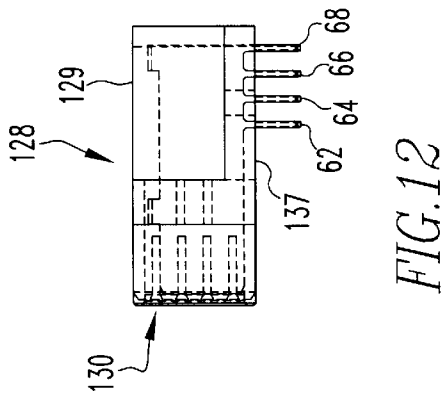
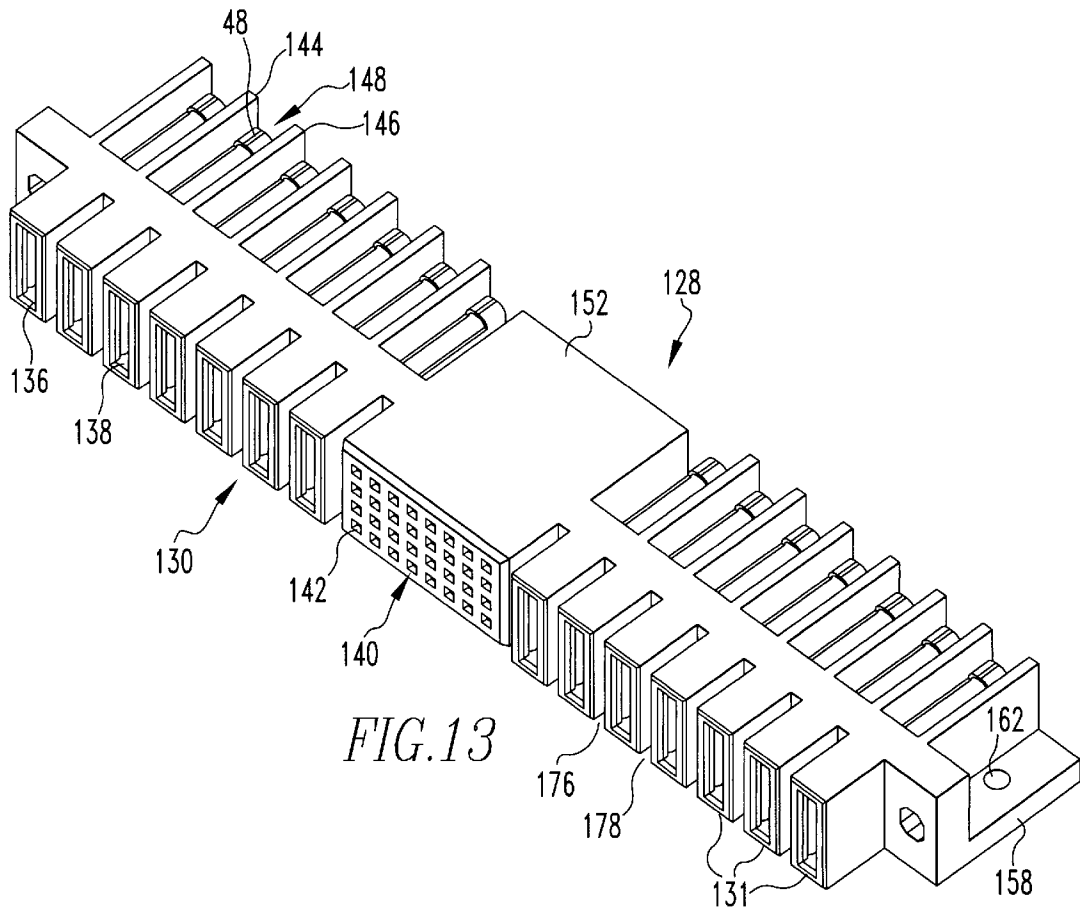
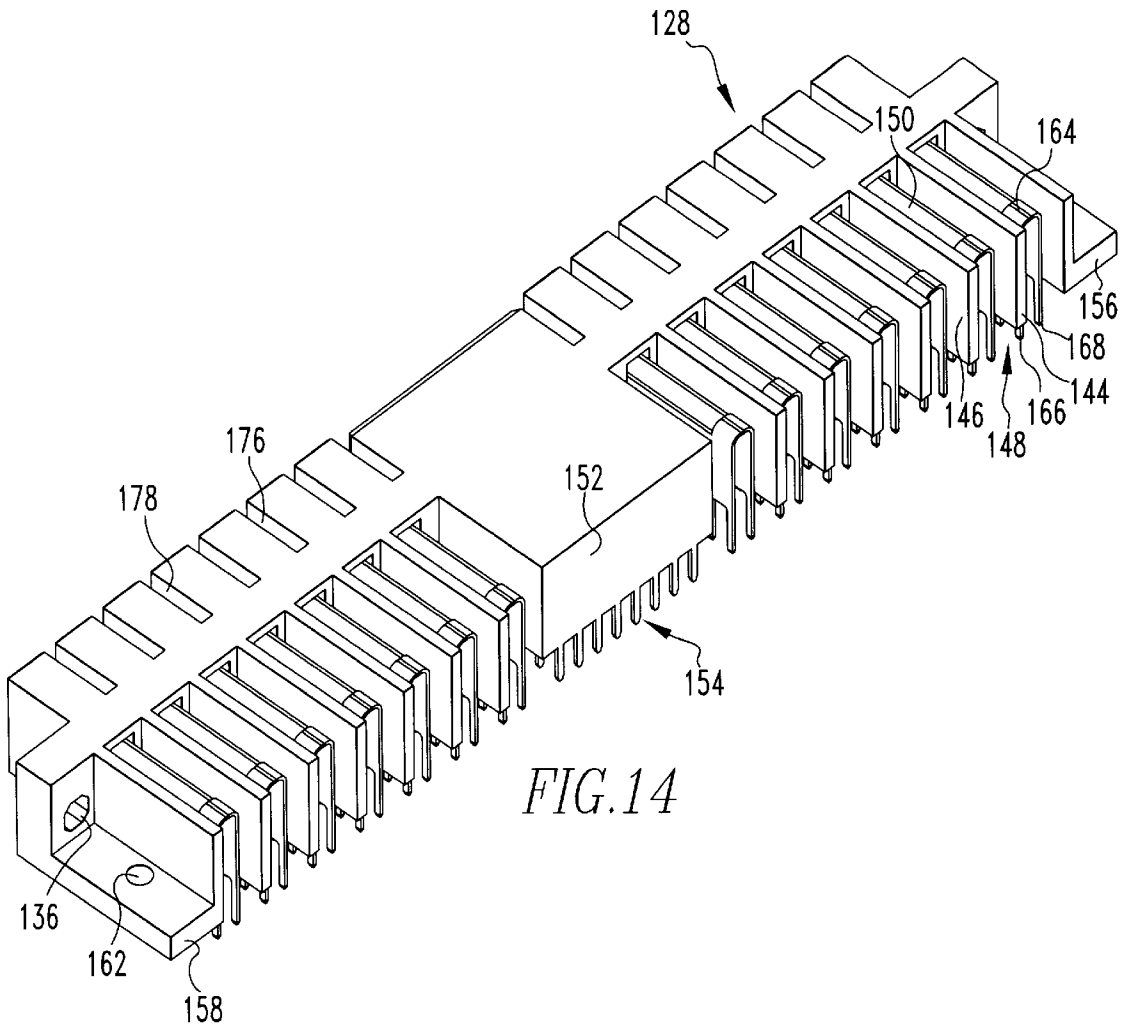

FIG. 12





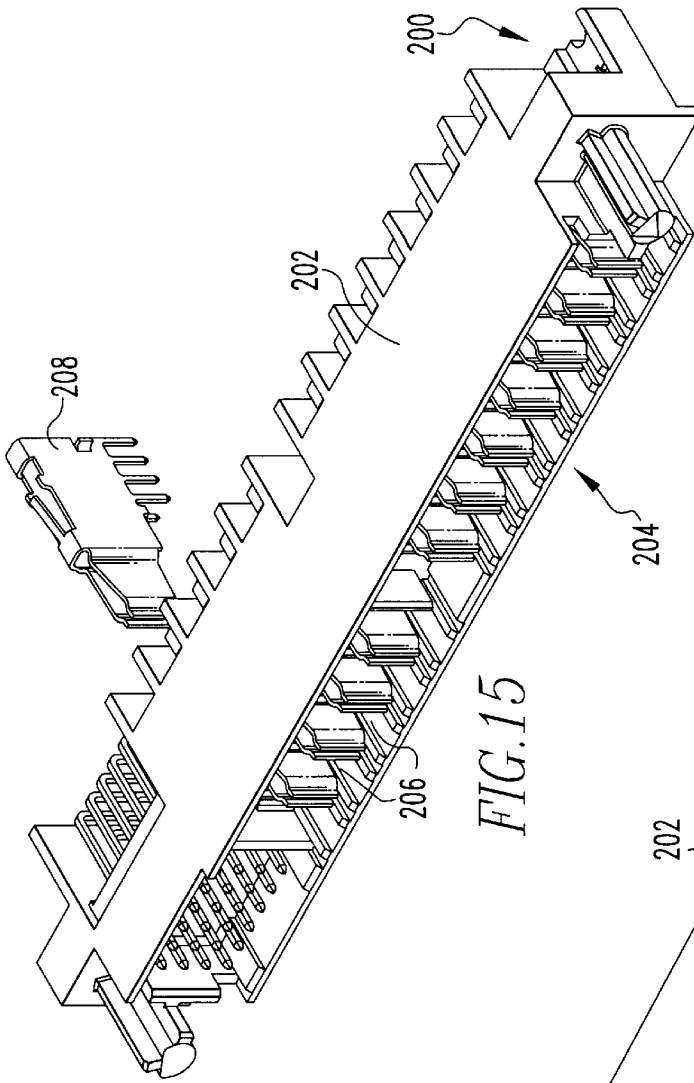

FIG. 15

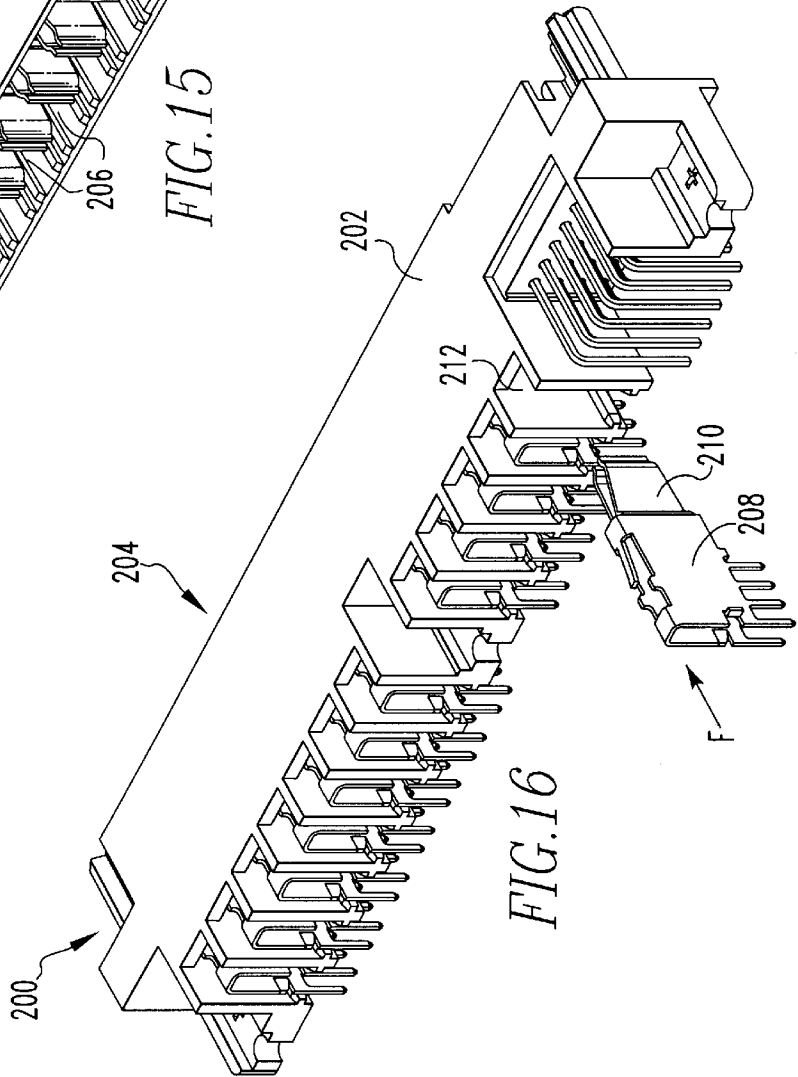

FIG. 16

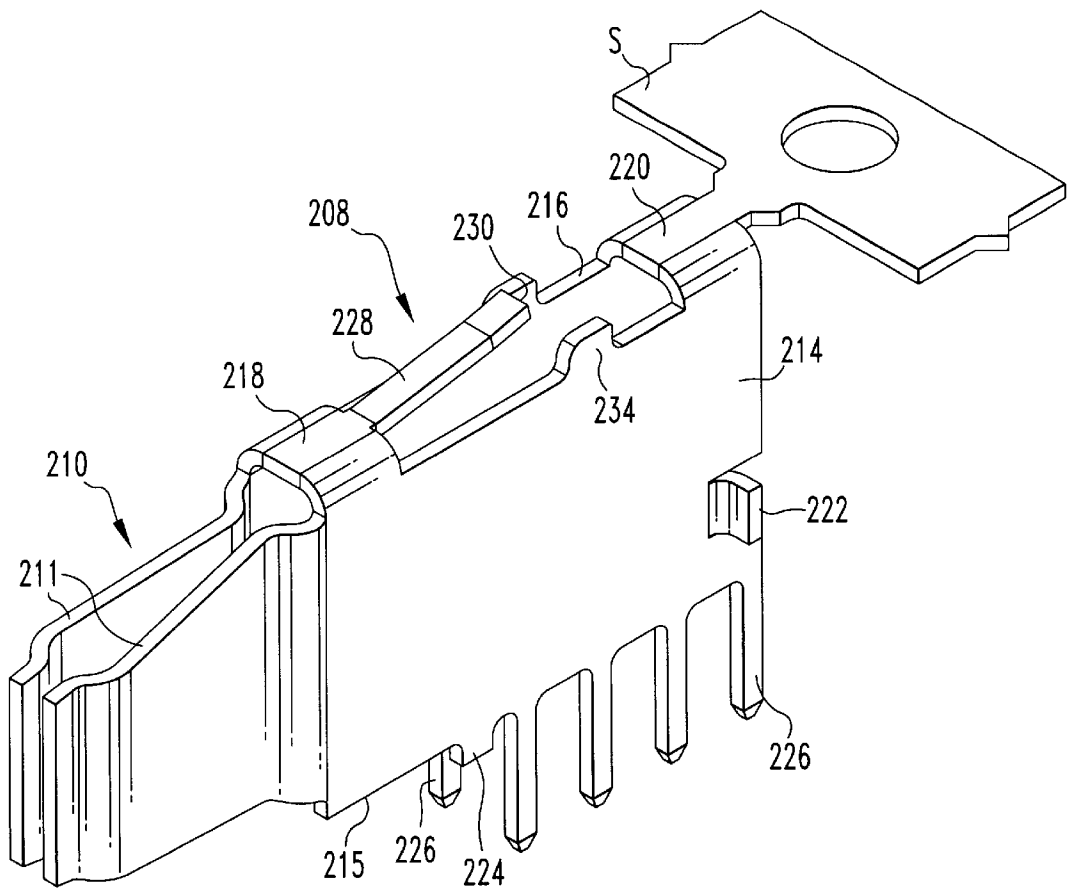
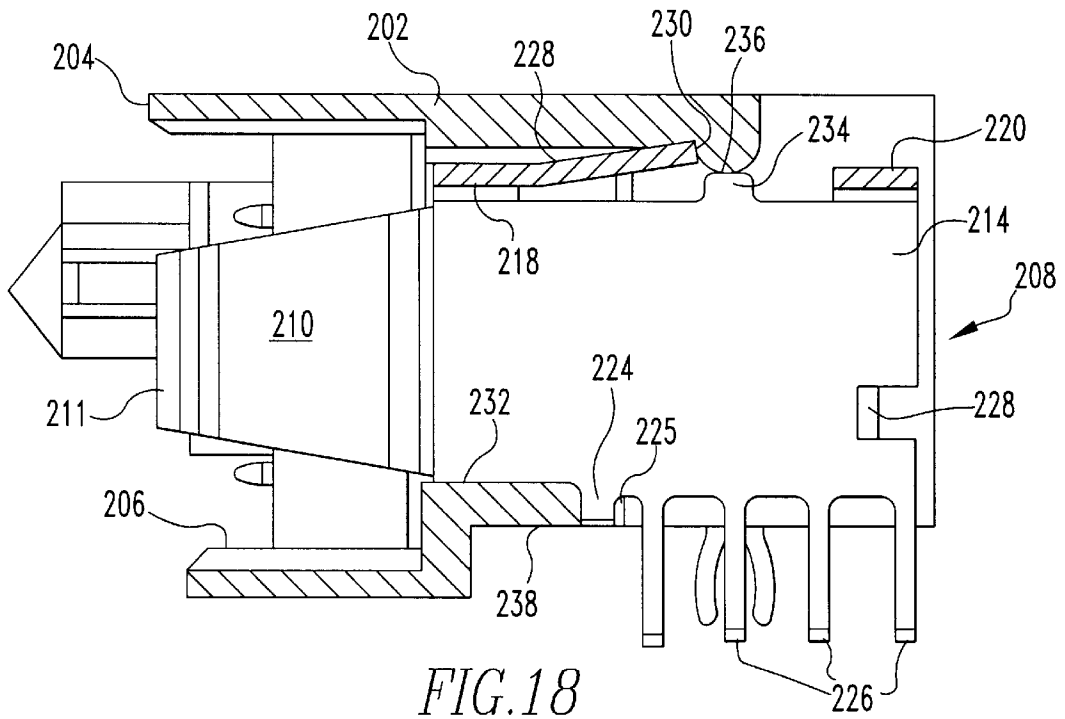

FIG. 17



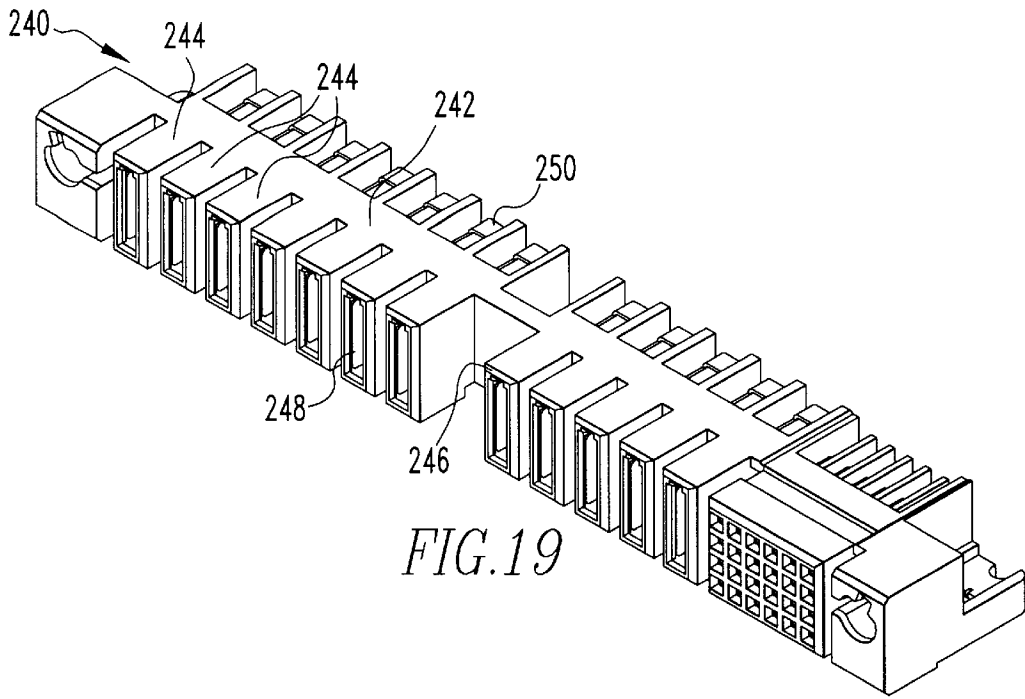

FIG. 19

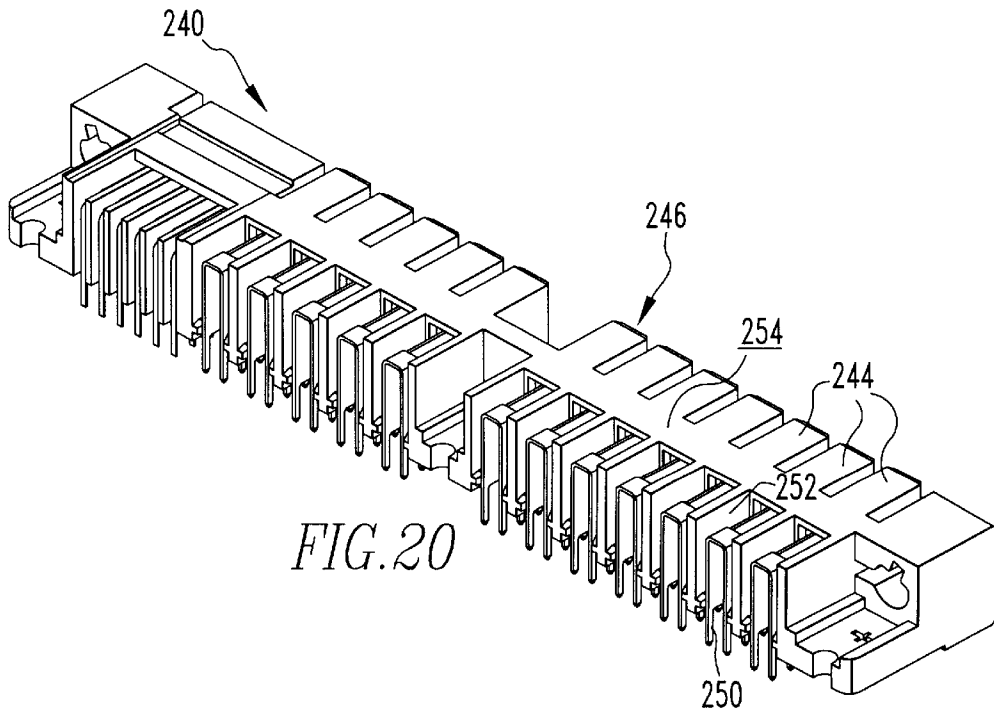

FIG. 20

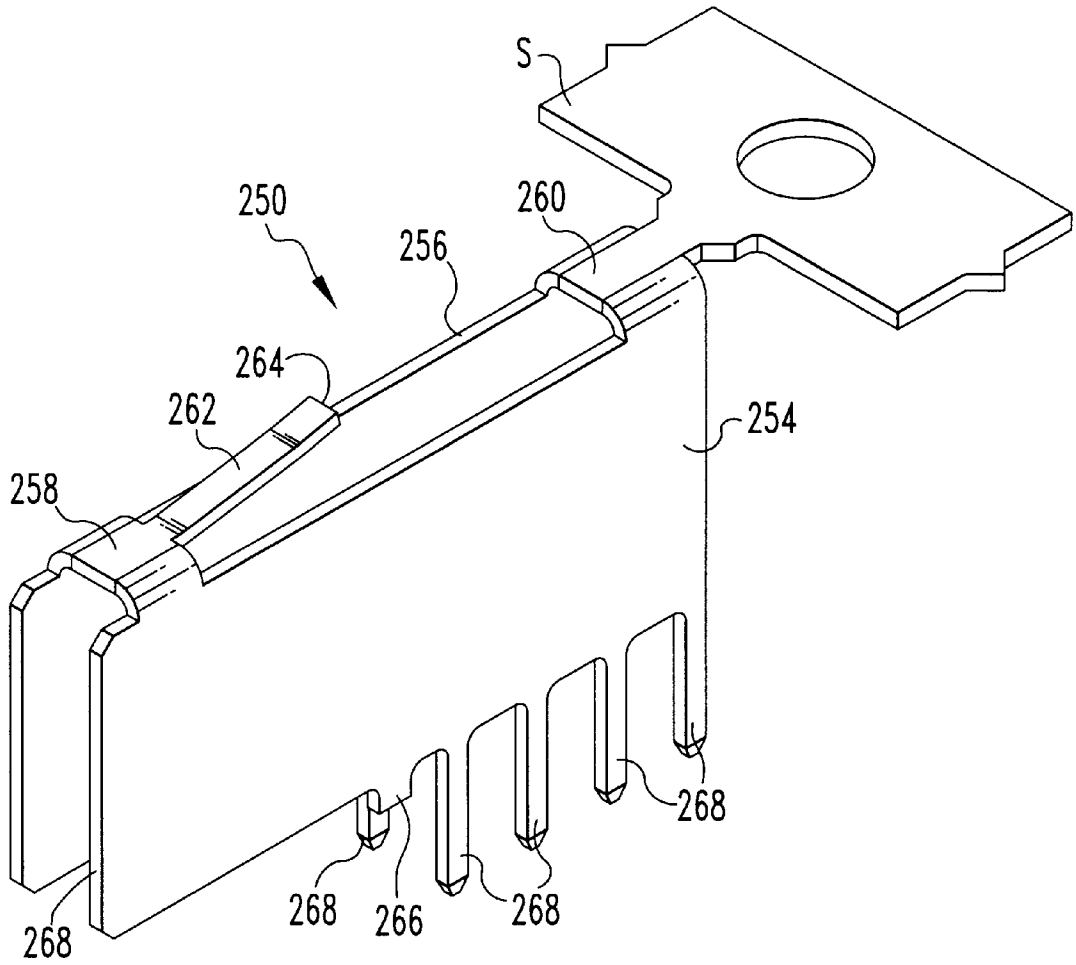

FIG. 21

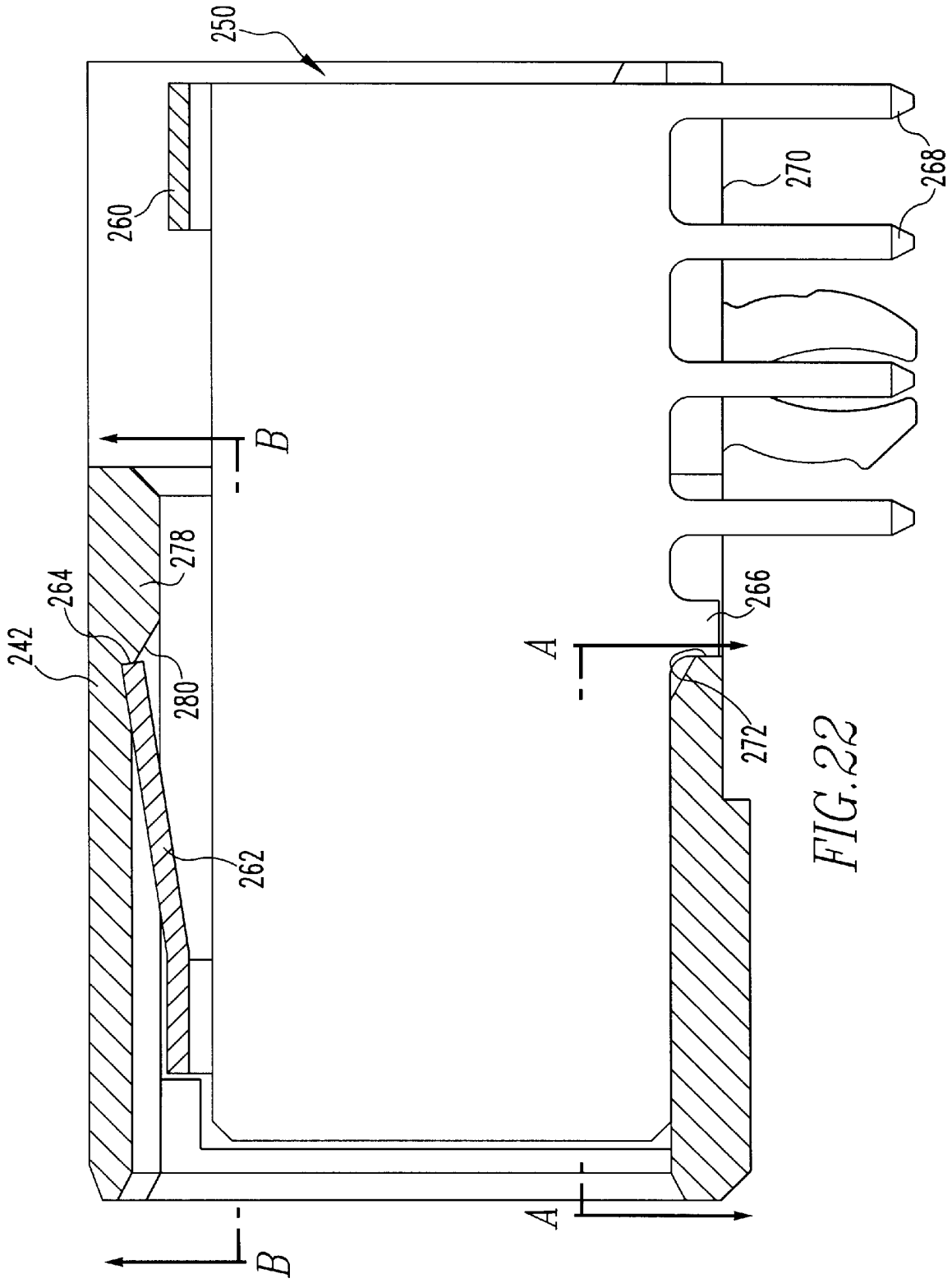

FIG. 22

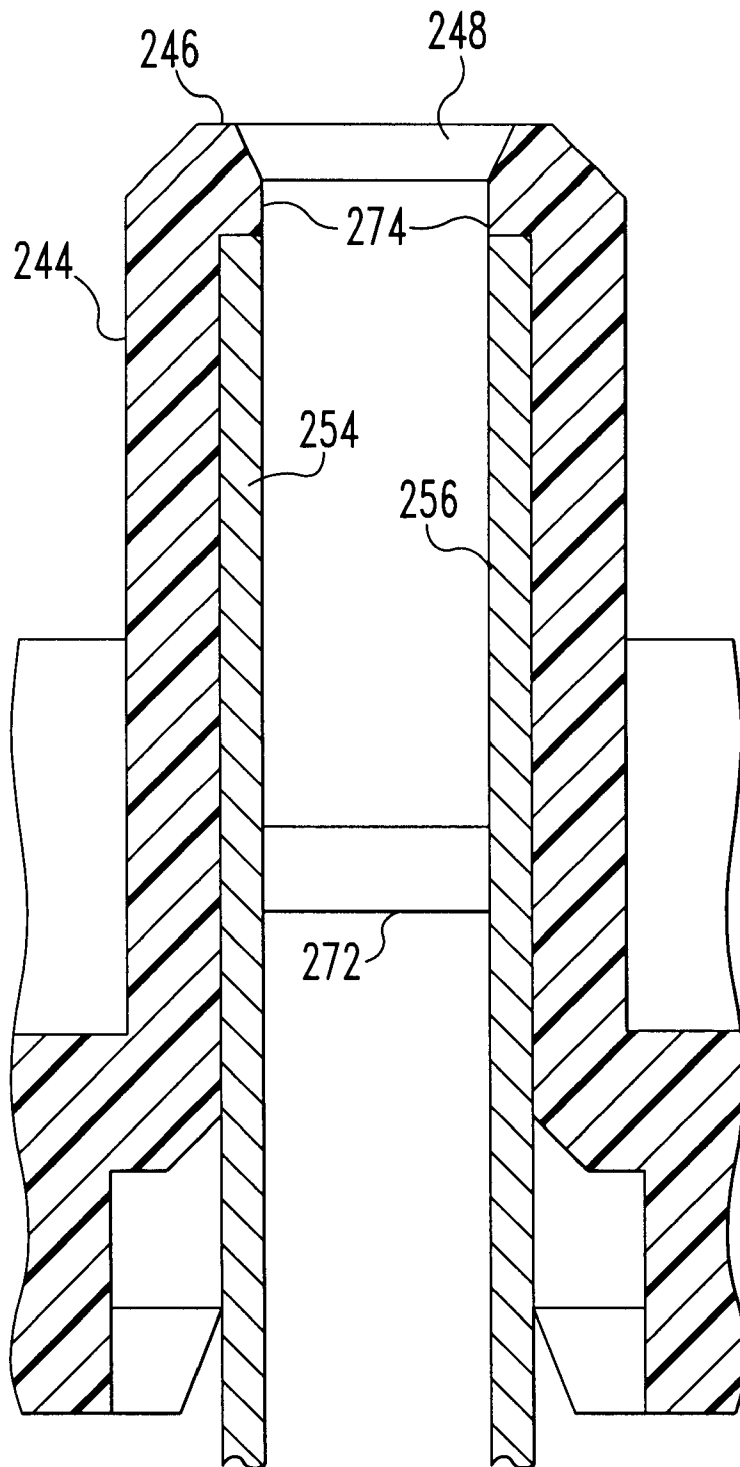

FIG. 22a

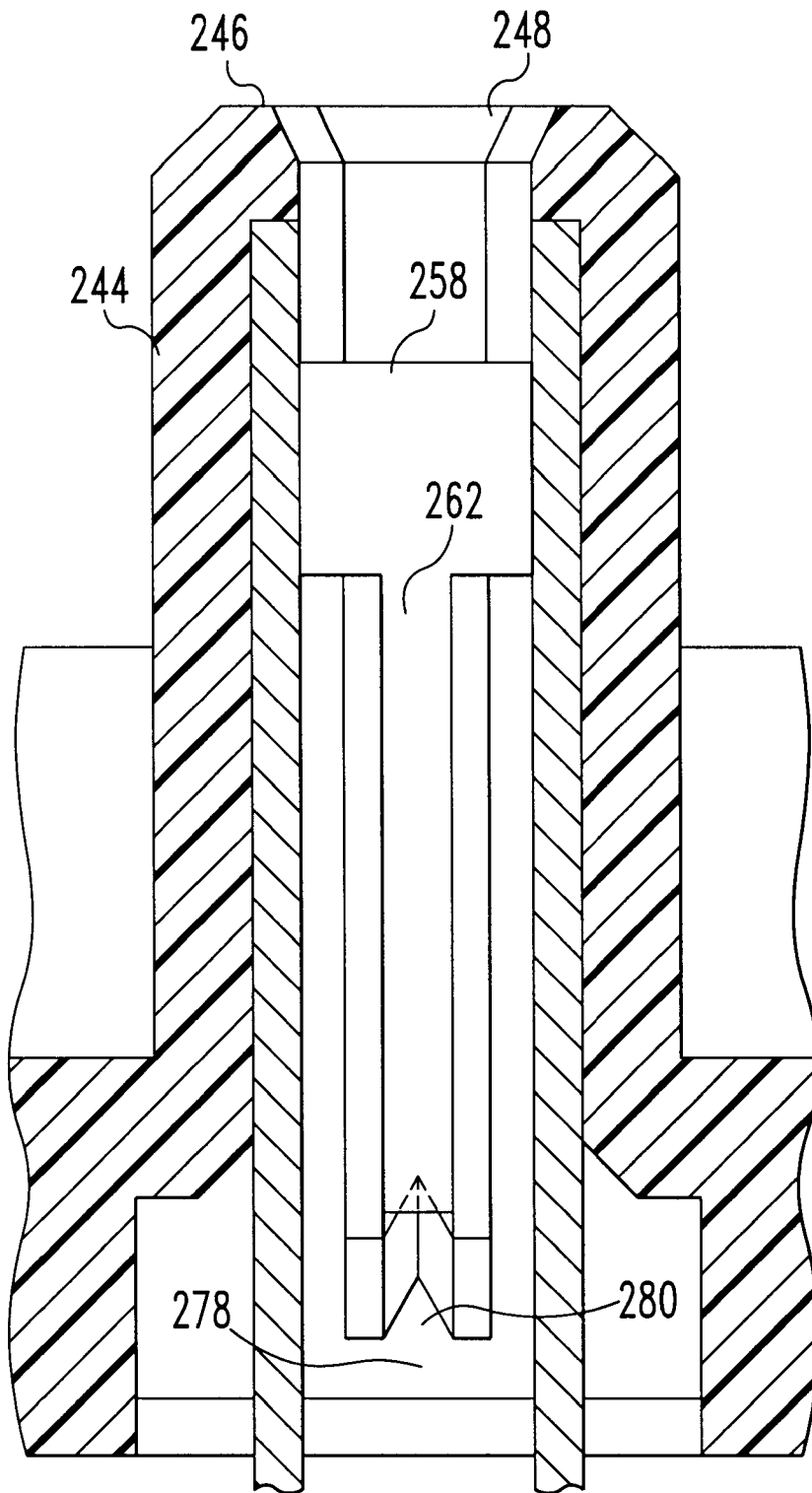

FIG. 22b

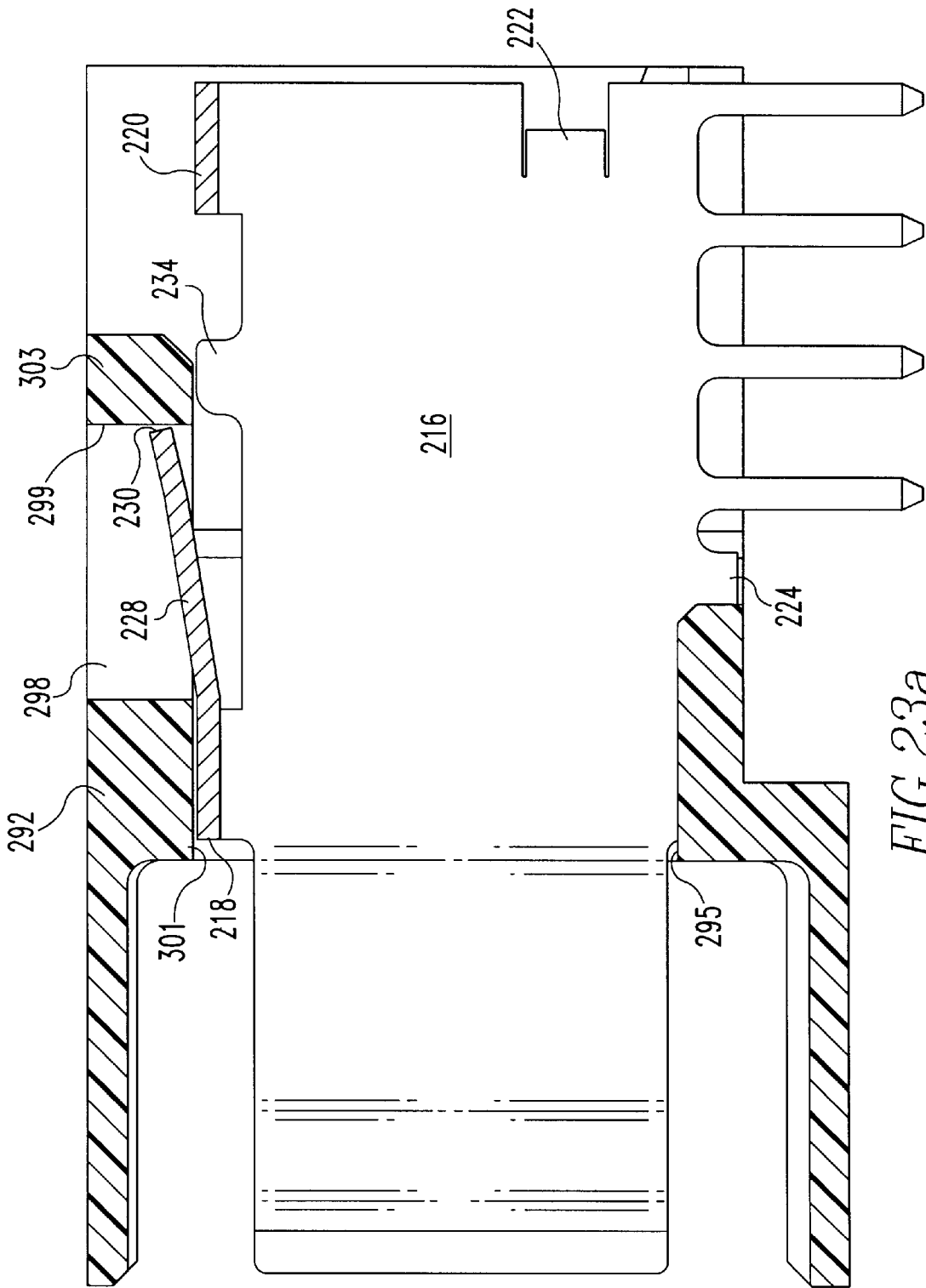

FIG. 23a

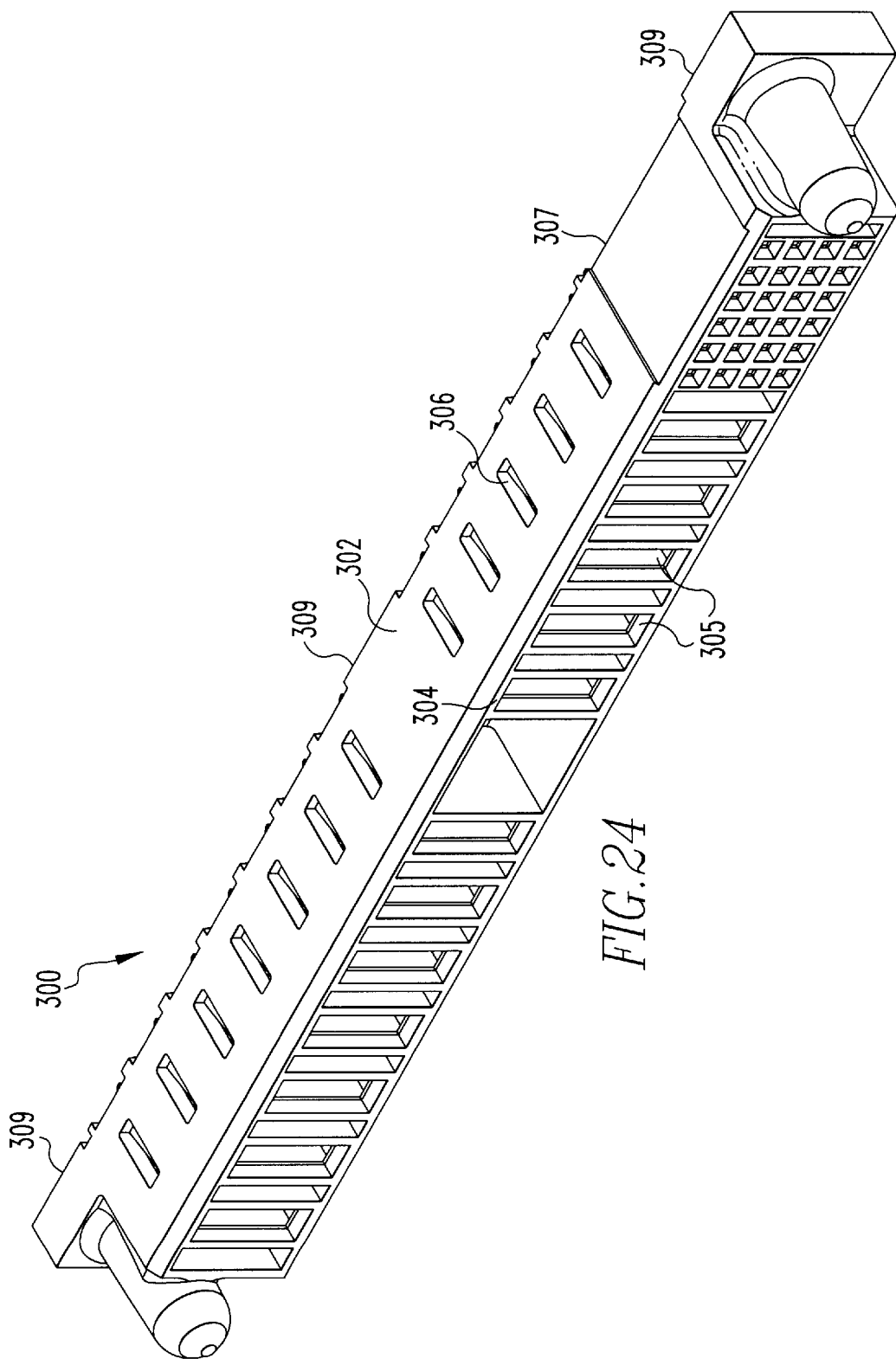

FIG. 24

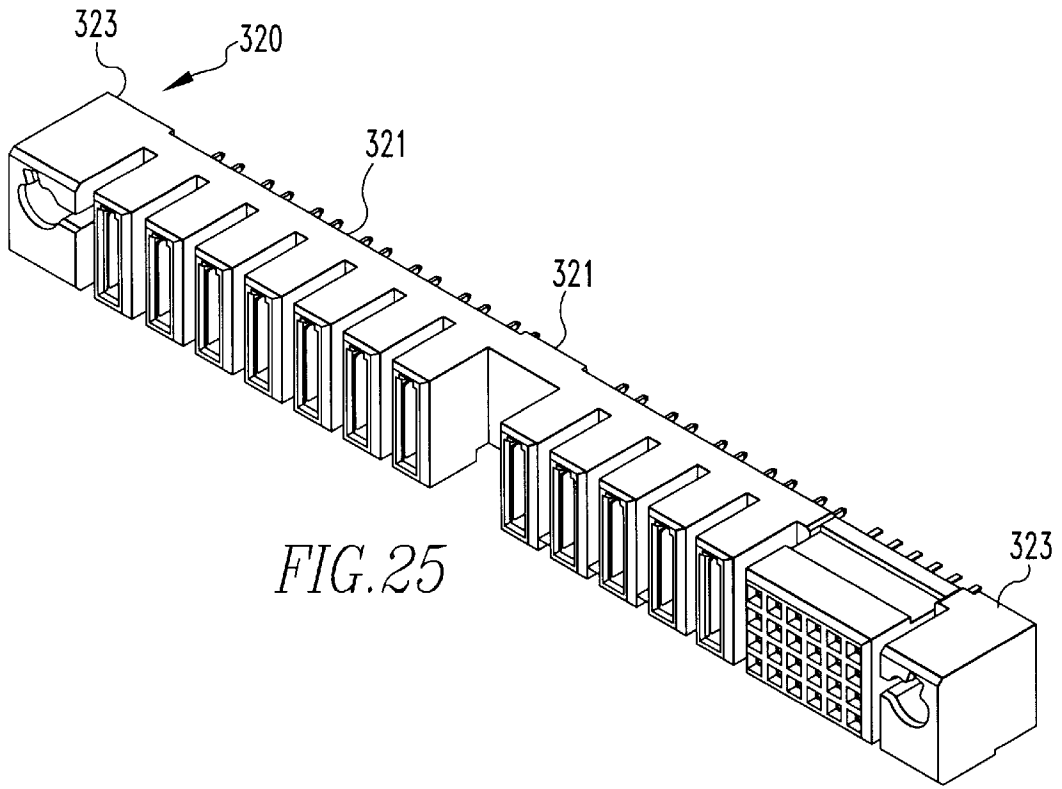

FIG. 25

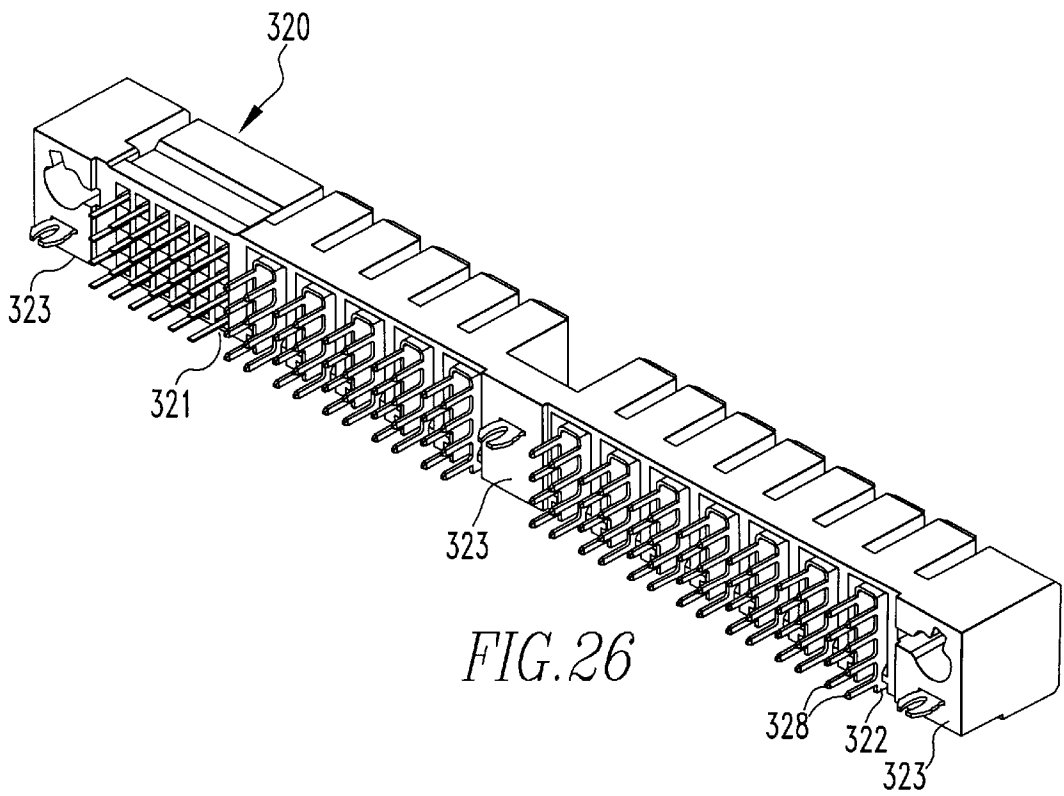
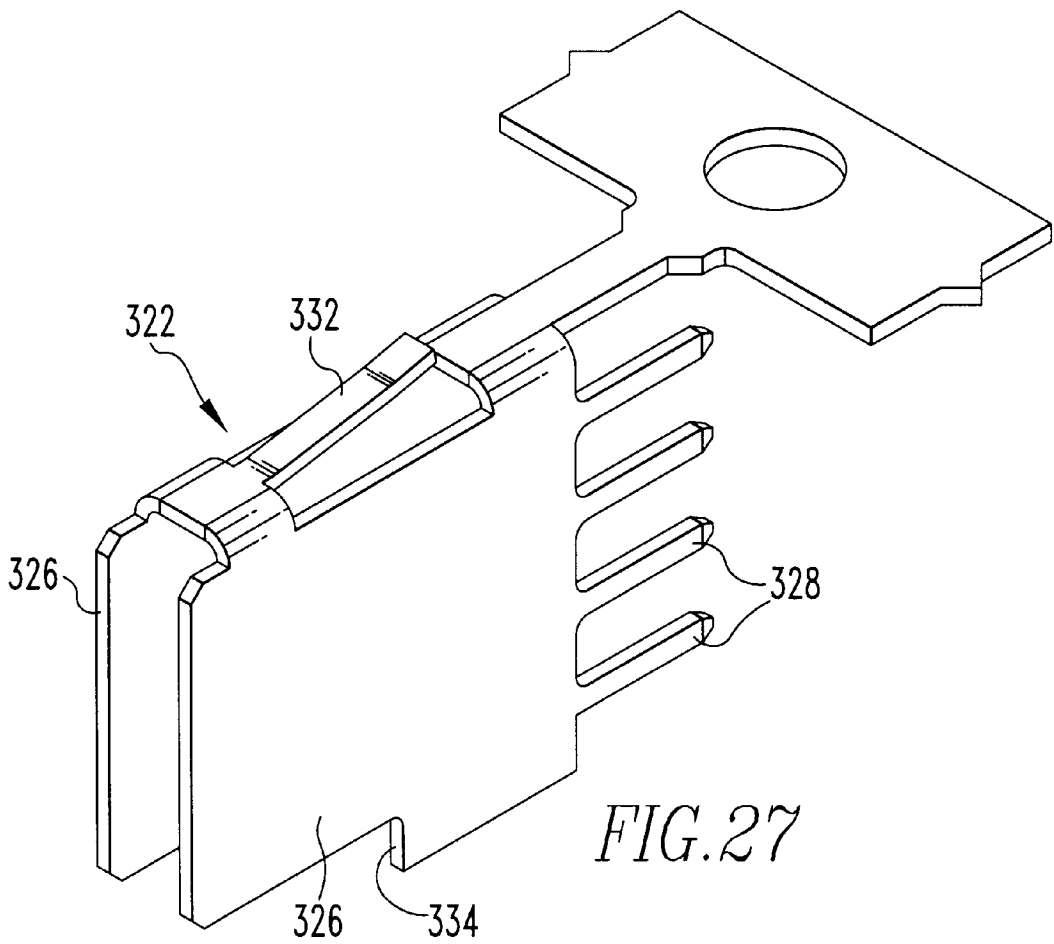

FIG. 26



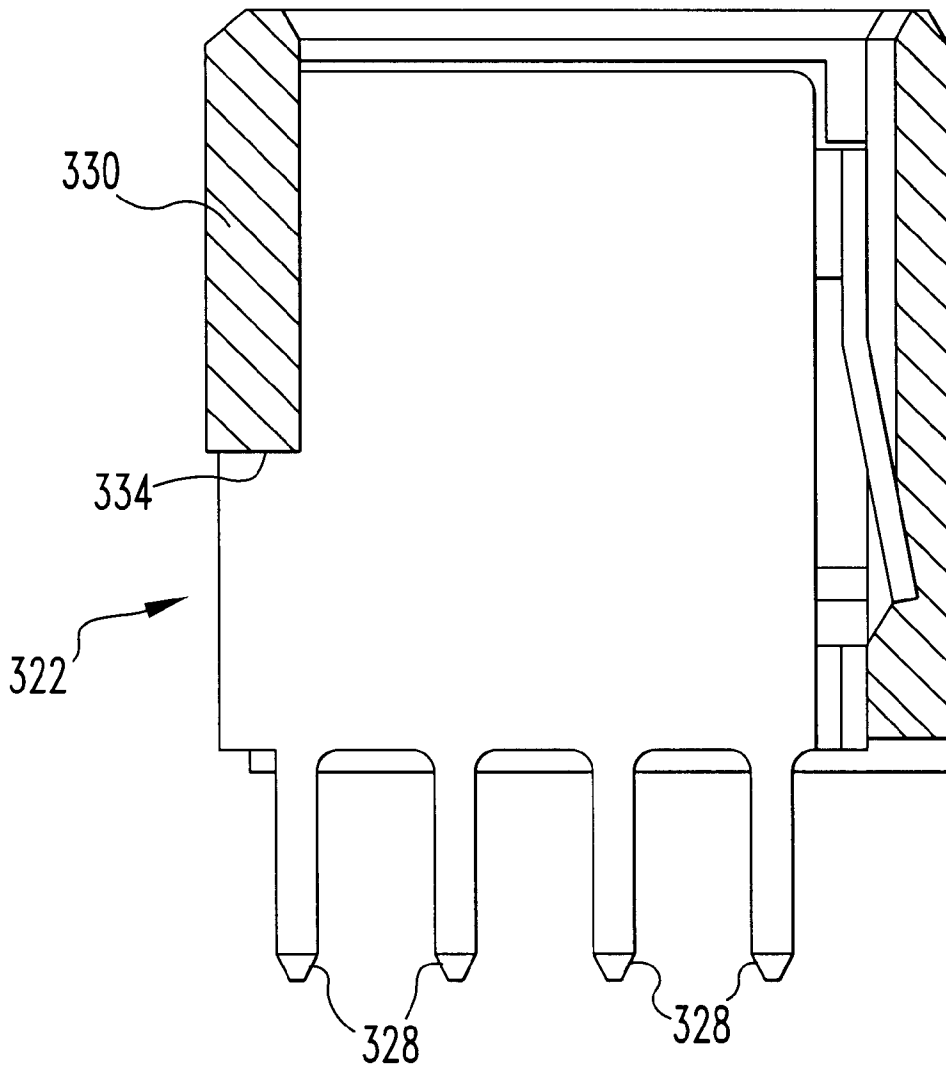

FIG. 28

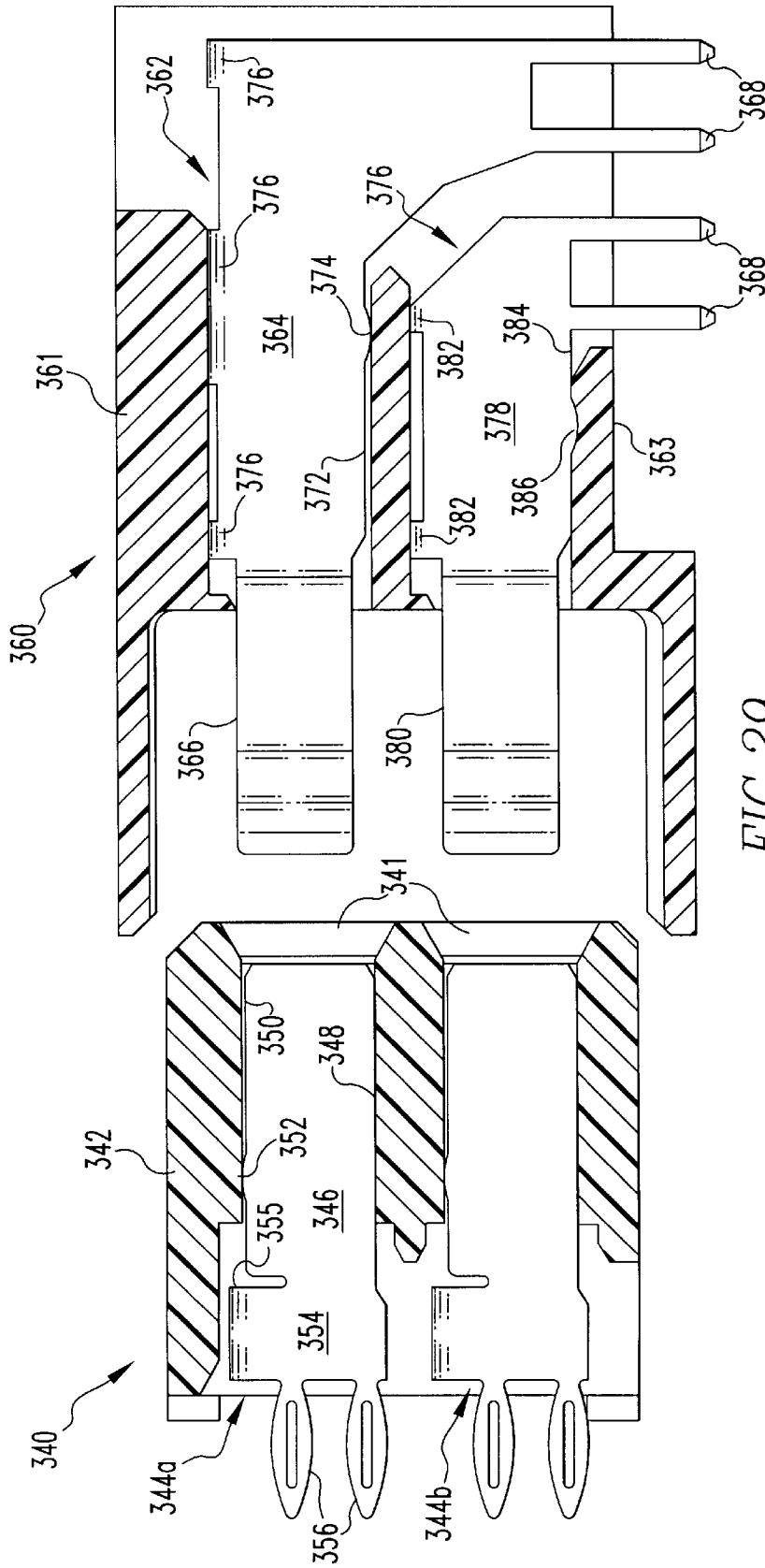

FIG. 29

1

POWER CONNECTOR**RELATED APPLICATION**

This application is based on U.S. Provisional Patent Application Ser. No. 60/082,091, filed Apr. 17, 1998.

BACKGROUND OF THE INVENTION

1. Field of the Invention

The present invention relates to electrical connectors and more particularly to electronic power connectors especially, useful in circuit board or backplane interconnection systems.

2. Brief Description of Prior Developments

Designers of electronic circuits generally are concerned with two basic circuit portions, the logic or signal portion and the power portion. In designing logic circuits, the designer usually does not have to take into account any changes in electrical properties, such as resistance of circuit components, that are brought about by changes in conditions, such as temperature, because current flows in logic circuits are usually relatively low. However, power circuits can undergo changes in electrical properties because of the relatively high current flows, for example, on the order of 30 amps or more in certain electronic equipment. Consequently, connectors designed for use in power circuits must be capable of dissipating heat (generated primarily as a result of the Joule effect) so that changes in circuit characteristics as a result of changing current flow are minimized. Conventional plug contacts in circuit board electrical power connectors are generally of rectangular (blade-like) or circular (pin-like) cross-section. These are so-called "singular-mass" designs. In these conventional singular-mass blade and pin configurations, the opposing receptacle contacts comprise a pair of inwardly urged cantilever beams and the mating blade or pin is located between the pair of beams. Such arrangements are difficult to reduce in size without adversely effecting heat dissipation capabilities. They also provide only minimal flexibility to change contact normal forces by adjustment of contact geometry.

There is a need for a small contact which efficiently dissipates heat and which has readily modifiable contact normal forces.

SUMMARY OF THE INVENTION

The present invention relates to electrical connectors that comprises a receptacle having an insulative housing and at least one conductive receptacle contact comprising a pair of spaced walls forming a plug contact receiving space. A mating plug comprises an insulative housing and at least one conductive contact having a pair of spaced walls which form a projection engageable in the plug receiving space of the receptacle contact. The contacts employ a "dual mass" principle that provides a greater surface area available for heat dissipation, principally by convection, as compared with "single-mass" contacts. This arrangement provides an air flow path through spaced portions of the contacts of the plug and receptacle connectors when mated.

BRIEF DESCRIPTION OF THE DRAWINGS

The present invention is further described with reference to the accompanying drawings in which:

FIG. 1 is a perspective view of a plug contact;

FIG. 2 is a side elevational view of the plug contact shown in FIG. 1;

FIG. 3 is a perspective view of a receptacle contact;

FIG. 4 is a side elevational view of the receptacle contact shown in FIG. 3;

FIG. 5 is a front elevational view of a plug connector;

FIG. 6 is a top plan view of the plug connector shown in FIG. 5;

FIG. 7 is an end view of the plug connector shown in FIG. 5;

FIG. 8 is a top front perspective view of the plug connector shown in FIG. 5;

FIG. 9 is a top rear perspective view of the plug connector shown in FIG. 5;

FIG. 10 is a front elevational view of a receptacle connector;

FIG. 11 is a top plan view of the receptacle connector shown in FIG. 10;

FIG. 12 is an end view of the receptacle connector shown in FIG. 10;

FIG. 13 is a top front perspective view of the receptacle connector shown in FIG. 10;

FIG. 14 is a top rear perspective view other receptacle connector shown in FIG. 1.

FIG. 15 is a front perspective view of a second embodiment of plug connector;

FIG. 16 is a rear perspective view of the plug connector of FIG. 15;

FIG. 17 is an isometric view of a plug contact used in the connector of FIG. 15, with the contact still attached to a portion of the strip material from which its formed;

FIG. 18 is a side cross-sectional view of the plug connector of FIG. 15;

FIG. 19 is a front perspective view of a receptacle connector matable with the plug connector of FIG. 15;

FIG. 20 is a rear perspective view of the receptacle connector shown in FIG. 19;

FIG. 21 is an isometric view of a receptacle contact used in the connector shown in FIG. 19, with the contact still attached to a portion of the metal strip from which it was formed;

FIG. 22 is a side cross-sectional view of the receptacle connector shown in FIG. 19;

FIG. 22a is a partial cross-sectional view taken along line AA of FIG. 22;

FIG. 22b is a partial cross-sectional view taken along line BB of FIG. 22;

FIG. 23 is a front perspective view of a third embodiment of plug connector;

FIG. 23a is a cross-sectional view of an alternative arrangement for securing a contact in a housing;

FIG. 24 is a front perspective view of a receptacle connector adapted to mate with the plug connector with FIG. 23;

FIG. 25 is a front elevational view of another embodiment of receptacle connector;

FIG. 26 is a bottom perspective view of the connector shown in FIG. 25;

FIG. 27 is an isometric view of a receptacle contact used in the connectors illustrated in the FIGS. 25 and 26;

FIG. 28 is a cross-sectional view of a connector as shown in FIG. 25; and

FIG. 29 is a cross-sectional view of an embodiment employing stacked contacts in the plug and receptacle connectors.

2

DETAILED DESCRIPTION OF THE PREFERRED EMBODIMENTS

Referring to FIGS. 1 and 2, a plug contact 10 for use in a plug connector is shown. This plug contact has two opposed major side walls 12 and 14. A front projection, identified generally by numeral 16, has an upper section 18 and a lower section 20. Each of these upper and lower sections comprises a pair of opposed cantilever beams, each beam having inwardly converging proximal section 22, arcuate contact section 24 and a distal section 26. The opposed distal sections 26 are preferably parallel to each other. The distal sections can be positioned slightly apart when the beams are in relaxed condition, but come together when the beams are deflected as the front projection is inserted into a receptacle contact (as explained below). This provides over-stress protection for the beams during mating. The side walls also include planar panels 28 and 30. Terminals 32, 34, 36 and 38 extend from an edge of panel 28. Terminal 40 extends from panel 30, along with a plurality of like terminals (not shown). Terminals 32-40 can comprise through hole, solder-to-board pins (as shown), press fit pins or surface mount tails. The panels 28 and 30 are connected by upper arcuate bridging elements 42 and 44. A medial space 46, adapted for air flow, is defined between the panels 28 and 30. The contact 10 is stamped or otherwise formed as a single piece from a strip of suitable contact materials such as phosphor bronze alloys or beryllium copper alloys.

Referring to FIGS. 3 and 4, receptacle contact 48 is shown. This receptacle contact has opposed, preferably planar and parallel side walls 50 and 52. These walls extend forwardly in a front projecting portion 54, that forms a medial plug receiving space 56. The distance between walls 50 and 52 at portion 54 is such that the projection 16 of the plug contact 10 is receivable in the plug contact receiving space 56, with the beams being resiliently deflected toward the center plane of contact 10. The deflection causes the beams to develop outwardly directed forces, thereby pressing the arcuate portions 24 against the inside surfaces of the portions 54 forming the receiving space 56, to develop suitable contact normal force. The side walls 50 and 52 also include, respectively, panels 58 and 60. Extending from panel 58 there are terminals 62, 64, 66 and 68. Extending from panel 60 there is terminal 70 as well as several other terminals (not shown). These terminals are essentially the same as previously described terminals 32-40. The side walls 50 and 52 are joined together by generally arcuate bridging elements 72 and 74. Preferably, the receptacle contact is also stamped or otherwise formed in a single piece from a strip of phosphor bronze alloy or beryllium copper alloy.

FIGS. 5-9 illustrate a plug connector 75 having an insulative plug housing 76. The housing 76 includes a front side 78 having a plurality of power contact apertures 84 and 86. The front projection or mating portion 16 (FIGS. 1 and 2) of the plug contacts is disposed in apertures 84, 86. The plug contacts 10 are retained in the housing 76 by an interference fit between the contact and the housing. This is accomplished by having the dimension H (FIG. 2), the dimension between bottom edge of wall 12 and the top of bridging element 42, slightly greater than the dimension of the cavity in housing 76 that receives this portion of plug contact 10. The front side 78 may also include a signal pin array opening 88 for housing a signal pin array designated generally as numeral 90. The housing 76 also includes a number of rear vertical partitions, such as partitions 92 and 94, which form power contact retaining slots 96 for housing

the plug contacts 98. The opposed medial vertical partitions 100 and 102 form between them a rear signal pin array space 104 for housing the rear portion 106 of the signal pins. The housing 76 also includes opposed rear mounting brackets 108 and 110 which have respectively mounting apertures 112 and 114. The plug contacts 10 have terminals 32, 34, 36, 38 and 40 extending below a bottom edge 80 of housing 76. The edge 80 forms a mounting interface, along which the housing is mounted to a printed circuit board or other structure on which the connector is mounted.

Referring to FIGS. 10-14, a receptacle connector 128 is shown. Receptacle 128 has an insulative housing 129 with a front side 130 including a plurality of silos 131 having contact openings, such as openings 136 and 138. The front side 130 forms a mating interface of the connector 128 for mating with plug connector 75. The silos 131 are configured and sized to be received in openings 84, 86 of connector 75. The front portions 54 (FIGS. 3-4) of the receptacle contacts are disposed within silos 131 and openings 134, 136 are sized and configured to receive the upper and lower sections 18 and 20 of plug contacts 10. The front side 130 has a signal pin receiving area 140 with signal pin receiving apertures. The housing 129 also has a plurality of rear partitions, such as partitions 144 and 146, which form contact retaining slots 148 for housing receptacle contacts 48. Signal pin housing 152 receives a signal receptacle contact array 154. The housing 129 also includes opposed rear mounting brackets 156 and 158 which have, respectively, mounting apertures 160 and 162. The receptacle contact terminals 62, 64, 66, 68 and 70 extend beneath surface 137, that forms the mounting interface of receptacle connector 128. The front side 130 of the housing 128 also has a plurality of vertical spaces 176 and 178, disposed between silos 131.

The receptacle contacts 48 are retained in housing 129 by an interference fit in essentially the same manner as previously described with respect to plug contacts 10. Retaining the contacts in this fashion allows substantial portions of the walls 12, 14 of the plug contact and walls 58, 60 of the receptacle contact to be spaced from surrounding parts of the respective housings 76 and 129. This leaves a substantial proportion of the surface area of both contacts (including the plug contacts), exposed to air, thereby enhancing heat dissipation capabilities, principally through convection. Such enhanced heat dissipation capabilities are desirable for power contacts.

FIG. 15 shows another plug connector 200 embodying the invention. In this embodiment, the housing 202, preferably formed of a molded polymeric material, has a front face 204 that forms the mating interface of the connector. The face 204 includes a plurality of openings, such as openings 206, formed in a linear array.

Referring to FIG. 16, the plug connector 200 includes a plurality of plug contacts 208. The contacts 208 are inserted from the rear of the housing into cavities 212 that extend from the rear of the housing toward the front of the housing. When the contacts 208 are fully inserted into the housing 202, the contact portions 210 with contacts 208 are disposed in the openings 206.

Referring to FIG. 17, the plug contact 208 is similar in many respects to the plug contacts shown in FIG. 1. It includes spaced panel-like walls 214, 216 that preferably are planar and substantially parallel. The walls 214, 216 are joined by a front bridging element 218 and a rear bridging element 220. In this embodiment, the contact section 210 is formed by two opposed cantilevered beams 211 that extend from front edges of the walls 214, 216. Preferably, each wall

includes a fixing tang **224** formed along a bottom of the edge of the wall. The walls **214**, **216** also include lateral positioning elements, such as bent tangs **222**, for centering the contact within cavities **212** in housing **202**. Each wall also includes a positioning feature, such as raised lug **234**.

The front bridging element **218** includes a rearwardly extending retention arm **228** that is cantilevered at its proximal end from the bridging element. Arm **228** includes a locating surface **230** at its distal end.

Terminals, such as through-hole pins **226**, extend from the bottom edge of each wall **214**, **216**. The terminals **226** can be solder-to-board pins (as shown) or can comprise press fit or other types of terminals.

As can be seen from FIG. **17**, the contacts **208** can be formed from sheet stock by stamping and forming the part from a strip of metallic stock suitable for forming electrical-contacts. The contacts **208** can be retained on a carrier strip **S** for gang insertion or separated from the strip prior to insertion into a housing.

Referring to FIG. **18**, the contact **208** is inserted into housing **202** from the rear into cavities **212** (FIG. **16**). The contact **208** is located (in the vertical sense of FIG. **18**) by engagement of the bottom edge **215** (FIG. **17**), against surface **232** of the housing and by engagement of the top edges of the lugs **234** with the rib **236** in the upper part of the housing. The contact is maintained centered within the cavity **212** by the lateral tangs **222** that engage side walls of the cavity **212**. The contact **208** is longitudinally locked in the housing (in the direction of contact mating) by means of the spring arm **228** that is deflected downwardly by the rib **236** of the housing during insertion and then resiles upwardly to position the stop surface **230** at its distal end against or near the forward surface of the rib **236**.

The downwardly extending tang **224** is preferably received in a slot **225** in the housing, the width of the slot being substantially the same as the thickness of the tang **224**. By capturing the tang **224** in the slot **225**, deformation of the wall section, as might occur when the cantilever arms **211** of the contact section are urged toward each other, is limited to the portion of the walls **212**, **216** disposed forwardly of the tangs **224**. This enhances control of the contact normal forces generated by deflection of the cantilever arms **211**.

As shown in FIG. **18**, the terminals **226** extend below the bottom surface **238** of the housing **202**, which bottom surface defines a mounting interface of the connector, along which it is mounted on a printed circuit board.

FIGS. **19** and **20** show a receptacle connector for mating with the plug connector illustrated in FIGS. **15**–**18**. The receptacle connectors **240** include an insulative housing **242** that comprises an array of receptacle silos **244**. The front surfaces **246** of the silos are substantially coplanar and form a mating interface of the connector. Each silo has an opening **248** for receiving the contact section **210** of the plug contacts **208** of the mating connector. The plurality of receptacle contacts **250** are mounted in the housing **242**, preferably by insertion from the rear into cavities **252**. As shown in FIG. **20**, preferably the top wall **254** of the housing does not extend fully to the rear of the connector housing, thereby leaving substantial openings in the cavities **252**.

The receptacle contact for receptacle connector **240** is illustrated in FIG. **21**. The contact **250** is similar in basic form to the receptacle contact **48** illustrated in FIGS. **3** and **4**. It includes two opposed walls **254**, **256** that are preferably substantially planar and parallel, thereby forming between them a contact receiving and air flow space. The walls **254**, **256** are joined by a front bridging element **258** and a rear

bridging element **260**. The front bridging element **258** includes a resilient latching arm that is cantilevered at its proximal end from bridging element **258** and carries at its distal end the latching or locking surface **264**. As described previously, the receptacle contact **250** can be formed in a single, unitary piece, by stamping and forming the contact from a strip. As mentioned previously, the contacts can be inserted into the housing while attached to carrier strip **S** or after being separated therefrom.

FIG. **22** is cross-sectional view showing a receptacle contact **250** inserted into housing **242**. As shown, the locating tang **266** is positioned with its forward surface against the locating surface **272** in the bottom wall of the housing **242**, thereby positioning the contact in its forward-most position. As the contact is inserted in the housing, the latching arm **262** is caused to resile downwardly when it engages the latching portion **278** of the housing. As the latching arm **262** resiles upwardly after it passes the latching section **278**, the locking surface **264** engages a raised rib **280** (FIG. **22b**) thereby locking the contact against rearward movement with respect to the housing. The terminals **268** extend beyond the surface **270** that forms the mounting interface of connector **240**.

As illustrated in FIGS. **22a** and **22b**, the forward portions of the walls **254**, **256** are disposed along inside side walls of the silos **244**. At the forward surface **246** of each silo, a plug contact receiving opening **248** is formed. The opening includes a pair of lips **274** that are coplanar with or extend just slightly beyond the inside surfaces of the walls **254**, **256**. This arrangement provides the benefit of lowered initial insertion forces when the connectors **200** and **240** are mated. As the silos **244** enter the openings **206** (FIG. **15**), the contact sections **210** formed by the cantilevered arms **211** first engage the surfaces of lips **274**. Because the coefficient of friction between the cantilevered arms **211** and the plastic lips **274** is relatively lower than the coefficient friction between the cantilevered arms and the metal walls **254**, **256**, initial insertion force is minimized.

FIG. **23** shows another embodiment of plug connector **290**. In this embodiment, the housing **292** has a single front opening **294** in which the contact sections **296** of the plug contacts are disposed. The housing also includes a plurality of openings **298** in the top wall of the housing. As shown in FIG. **23a**, the bridging element **218** and locating lug **234** engage the top surface **301** of the contact receiving cavity and the bottom surface **295** of the cavity in an interference fit. The arm **228** deflects downwardly as the contact is inserted into the housing and the arm engages portion **303**. When the arm **228** clears portion **303**, the arm resiles upwardly to locate stop surface **230** adjacent surface **299**, thereby locking the contact against retraction. The openings **298** are positioned above the latching arms **228** (FIG. **18**), to allow the arm **228** to be moved from a retention position and the contacts to be withdrawn from the housing. This can be accomplished by insertion of a suitable tool (not shown) through opening **298**. Openings **298** can also provide air flow passages for enhancing heat dissipation.

FIG. **24** illustrates a receptacle connector **300** adapted to mate with plug connector **290**. The receptacle connector **300** employs a housing **302** having a continuous front face **304**, rather than a plurality of silos as in previous embodiments. The entire front face **304** of the connector **300** is received in opening **294**, with the contact sections **296** inserted into openings **305** of face **304**. Openings **306** in the top wall of the housing allow access to the latching arms of the receptacle contacts (not shown) as described in the previous embodiment.

The embodiment of FIG. 24 and also the embodiment of FIGS. 25 and 26 are meant for use in a vertical configuration, as opposed to a right angle configuration. The housing 302 of connector 300 (FIG. 24) has a bottom side 307. Preferably, a plurality of standoff surfaces 309 form a mounting interface, along which the housing is mounted on a substrate, such as a printed circuit board. Similarly, the housing of connector 320 has a bottom surface 321 with standoffs 323. Appropriate receptacle contacts 322 (FIG. 7) are inserted into the housings of connectors 300 and 320 from the bottom sides 307 and 321, respectively.

FIG. 27 shows a receptacle contact 322 comprising a pair of preferably planar parallel walls 324, 326 that form between them a contact receiving space for receiving plug contacts of the type previously described. This contact has terminals 328 extending from a rear edge of each of the walls. As shown in FIG. 28, the contact 322 is received in housing 330 in a manner similar to that previously described, wherein the resilient latching arm locks the contact against downward (in the sense of FIG. 28) movement, while a locating surface 334 locates the contact in the opposite direction with respect to the housing. The terminals 328 extend beyond the plane of the mounting interface of the connector housing for insertion into through holes in the printed circuit board.

FIG. 29 shows an embodiment employing two sets of contacts at each location, in a stacked configuration. The receptacle connector 340 has a housing formed of insulative material. The housing 342 includes a mating interface having a plurality of openings 341. Each of the openings 341 open into cavities in housing, which cavities receive substantially identical receptacle contacts 344a and 344b. Each of the contacts 344a and 344b is similar in general construction to the receptacle contacts previously described, there being a pair of such contacts in each cavity, generally aligned along the side walls thereof, to form a gap between generally parallel plate sections 346. The plate sections 346 have two opposed edges 348 and 350, one of which carries a retention feature, such as interference bump 352. The receptacle contact sections 356 are retained in the housing by suitable means, such as an interference fit created by the bump 352. Each contact section 356 includes a generally coplanar wall section 354. The wall sections 354 are joined by a bridge section 355. Suitable terminals, such as press fit terminals 356 extend from an edge of the wall section 354, in the case where the connector 340 is to be used in a vertical configuration.

The mating plug connector 360 includes a molded polymeric body 361 that receives a pair of plug contacts, such as upper plug contact 362 and the lower plug contact 376. These plug contacts are configured generally in the manner previously described, namely, being formed of a pair of spaced wall sections 364 and 368 respectively joined by bridging elements and carrying opposed contact beams 366 and 380 to engage the spaced receptacle plates 346. The plug contact 362 includes a single, relatively long, or several, relatively short, bridging elements 376 that join two opposed plates 364. The bottom edge 372 of each of the plates 364 includes retention structure, such as an interference bump 374. The plug contact 362 is retained in its cavity within housing 361 by an interference fit between the bridging elements 376 and the interference bump 374, although it is contemplated that other retention mechanisms could be utilized. Similarly, lower plug contacts 376 comprise a pair of coplanar wall or panel members 378 joined by one or more bridging elements 382. The lower edge 384 of each wall 378 includes an interference bump 386, that functions

to create an interference fit, as previously described. Suitable terminals 368 and 380 extend from each of the panels 364 and 368, beyond the mounting interface 363 of the housing 361, for associating each of the contacts 362 and 376 with electrical tracks on the printed circuit board on which the plug 360 is to be mounted.

The previously described receptacle and plug contacts may be plated or otherwise coated with corrosion resistant materials. Also, the plug contact beams may be bowed slightly in the transverse direction to enhance engagement with the contact receiving surfaces of the receptacle contacts.

The "dual-mass" construction of both receptacle and blade contacts, employing opposing, relatively thin walls, allows for greater heat dissipation as compared with prior "singular-mass" designs. In comparison with "singular mass" connectors of similar size and power handling capabilities, the "dual mass" connectors, as disclosed have approximately two times the surface area. The enhanced current flow and heat dissipation properties result from the contacts having greater surface area available for convection heat flow, especially through the center of the mated contacts. Because the plug contacts have an open configuration, heat loss by convection can occur from interior surfaces by passage of air in the gap between these surfaces.

The contacts also contain outwardly directed, mutually opposing receptacle beams and dual, peripherally located, mating blades, in a configuration which can allow for flexibility in modifying contact normal forces by adjustment of the contact connector geometry. This can be accomplished by modifying the bridging elements to change bend radius, angle, or separation of the walls of the contacts. Such modifications cannot be accomplished with conventional singular-mass beam/blade configurations wherein the opposing receptacle contacts are inwardly directed, and the mating blade is located in the center of said beams.

Such dual, opposing, planar contact construction also allows for easier inclusion of additional printed circuit board attachment terminals with more separation between terminals, compared to an equivalent "singular-mass" bulk designs. The use of relatively larger plates in the plug and receptacle contacts gives this opportunity for providing a plurality of circuit board terminals on each contact part. This lessens constriction of current flow to the printed circuit board, thereby lowering resistance and lessening heat generation.

The use of a compliant plug mating section allows the receptacle contacts to be placed in a protected position within the molded polymeric housing for safety purposes. This feature is of further benefit because it allows minimization of amount of polymeric material used in making the housing. This lowers material costs and enhances heat dissipation. Also, by retaining the contacts in the housing in the manner suggested, thick wall structures can be avoided and thin, fin like structures can be utilized, all of which enhances heat dissipation from the connectors. Additionally, first-make, last break functionality can be incorporated easily into disclosed connector system by modifying the length of the mating portion of the plug contacts or by changing the length of the plug-receiving portion of the receptacle contacts.

The arch connection structure between opposing rectangular contact sections also allows for attachment of retention means, such as a resilient arm structure as shown in one of the current embodiments, in a manner that does not limit current flow or hinder contact heat dissipation capability.

It will also be appreciated that the plug and receptacle contacts may be manufactured from closely similar or identical blanks thereby minimizing tooling requirements. Further, the plug or receptacle connectors can easily be associated with cables, by means of paddle boards.

While the present invention has been described in connection with the preferred embodiments of the various figures, it is to be understood that other similar embodiments may be used or modifications and additions may be made to the described embodiment for performing the same function of the present invention without deviating therefrom. Therefore, the present invention should not be limited to any single embodiment, but rather construed in breadth and scope in accordance with the recitation of the appended claims.

What is claimed is:

1. A terminal for an electrical connector comprising:
 - a pair of spaced generally planar walls;
 - a bridging structure extending between and joining the walls, said bridging structure including forward and rearward bridging elements extending between the walls; and
 - a resilient, movable retention element on the bridging structure and extending outwardly and between said forward and rearward bridging elements, the retention element being movable to generate forces directed in the planes of the walls; and
 - a space between the forward and rearward bridging elements, said space defines a generally open upper section for heat dissipation.
2. A terminal as in claim 1, wherein the bridging structure is integral with the walls and the retention element comprises a cantilevered arm extending from the bridging structure.
3. A terminal as in claim 2, wherein the arm includes a locking surface near a distal portion thereof.
4. A terminal as in claim 2, wherein the walls, the bridging structure and retention member are integrally formed from a single piece of conductive material.
5. A terminal as in claim 4, wherein the walls are substantially parallel.
6. The terminal as in claim 1, further comprising a mating section extending from each of the walls, said mating sections tapered from a proximal end to a distal end.
7. The terminal as in claim 1, further comprising a mating section extending from each of the walls, wherein distal ends of said mating sections can abut each other to prevent overstress during mating.
8. An electrical connector adapted to mate with another electrical connector having a terminal with first and second spaced walls, the connector comprising:
 - an insulative housing having a terminal cavity opening to a mating face of the housing, the terminal cavity having spaced, opposing side walls;
 - a terminal disposed in the terminal cavity, the terminal including:
 - spaced walls, each wall being disposed adjacent a portion of one said cavity side walls and having a

- lateral tang extending therefrom, a first edge, a second opposed edge, and a front projection extending therefrom to engage a mating section between the first and second spaced walls of the terminal of the mating connector; and
 - a bridging element extending between the contact walls and located adjacent the first edges of the contact walls, said bridging element having an open upper section in a central portion thereof for heat dissipation; and
 - a resilient member engageable with a portion of the terminal cavity extending between the side walls for retaining the plates along said side walls with a space between the plates, said resilient member having a length shorter than that of said open upper section of said bridging element.
9. A connector system, comprising:
 - (A) a connector, said connector further comprising:
 - an insulative housing having a terminal cavity opening to a mating face of the housing, the terminal cavity having spaced, opposing side walls;
 - a plug contact disposed in the terminal cavity, the plug contact including:
 - spaced walls, each wall being disposed adjacent a portion of one said cavity side walls and having a first edge, a second opposed edge, and a front projection extending therefrom; and
 - a bridging element extending between the contact walls and located adjacent the first edges of the contact walls, said bridging element having an open upper section therein for heat dissipation; and
 - (B) a mating connector having a receptacle contact for receiving said front projection therein, said mating connector further comprising:
 - an insulative housing having a terminal cavity opening to a mating face of the housing, the terminal cavity having spaced, opposing side walls;
 - said receptacle contact disposed in the terminal cavity, said receptacle contact including:
 - spaced walls, each wall being disposed adjacent a portion of one said cavity side walls and having a first edge, a second opposed edge, and a mating section between said spaced walls to receive said projection therein; and
 - a bridging element extending between the contact walls and located adjacent the first edges of the contact walls, said bridging element having an open upper section therein for heat dissipation.
 10. The connector system of claim 9, wherein the bridging elements of both said connectors have a resilient retention member.
 11. The connector system of claim 10, wherein said resilient retention members of both said connector and said receptacle extending at least partially over said open upper section of said connector and receptacle, respectively.

* * * * *