



Missouri University of Science and Technology
Scholars' Mine

International Specialty Conference on Cold-Formed Steel Structures

(1990) - 10th International Specialty Conference on Cold-Formed Steel Structures

Oct 23rd, 12:00 AM

Cold-formed Steel Products in Material Handling System Projects: Indian Experience

Manhar C. Thakkar

Follow this and additional works at: <https://scholarsmine.mst.edu/isccss>

 Part of the [Structural Engineering Commons](#)

Recommended Citation

Thakkar, Manhar C., "Cold-formed Steel Products in Material Handling System Projects: Indian Experience" (1990). *International Specialty Conference on Cold-Formed Steel Structures*. 1. <https://scholarsmine.mst.edu/isccss/10iccfss/10iccfss-additional/1>

This Article - Conference proceedings is brought to you for free and open access by Scholars' Mine. It has been accepted for inclusion in International Specialty Conference on Cold-Formed Steel Structures by an authorized administrator of Scholars' Mine. This work is protected by U. S. Copyright Law. Unauthorized use including reproduction for redistribution requires the permission of the copyright holder. For more information, please contact scholarsmine@mst.edu.

**COLD-FORMED STEEL PRODUCTS IN MATERIAL
HANDLING SYSTEM PROJECTS:
INDIAN EXPERIENCE**

**DR MANHAR C THAKKAR
MANAGER (DESIGN)
ELECON ENGG. CO. LTD
VALLABH VIDYANAGAR 388120
INDIA**

SUMMARY

Use of cold formed steel products in Material Handling System Project is pioneered by the author in India. Problems & Prospects are discussed alongwith examples of decking plates and conveyor stringers. Present day economics favour CRFS vis-a-vis hot rolled steel sections.

INTRODUCTION

With significant spurt in industrial construction after Independence, material handling industry in India has made enviable growth. In any industrial project related to power, steel, fertiliser, foodgrains, ports, mining or cement sectors; material handling systems installed in India speak volumes for new innovations, new materials & forms, new technology; a lot of which developed indigenously in India.

Structural steel being backbone of material handling systems, rationality in planning, design & construction in basic prerequisite. In India where hot rolled steel products being short in supply and at premiums: a situation has given a rise to development of cold formed steel products particularly in material handling systems.

Conveyor structures (Fig 1) and conveyor frame components have been examined in details. Cold formed alternatives vis-a-vis hot rolled products are worked for applications such as conveyor stringers, conveyor deck plates, short supports, seal plates, purlins, side sheeting runners, walkway runners and conveyor covers.

Out-of-these various cold formed applications developed by the author, many have been used in several material handling system projects in last decade. Apart from proving economical, these cold formed products proved to be technically superior. Stresses & deflections were much reduced and failures averted.

Typical examples from various projects already executed for decking plates & conveyor stringers are given.

DECKING PLATES

Between carrying & return side of conveyor belt, these decking plates are provided so as to prevent spillage going over return side of belt. Such spillage if allowed would damage the conveyor belt (cover is quite less on return side. Even belt carcass would also get damaged) and pulleys.

Till now these decking plates were being manufactured by welding an angle to the plate & by bending the edges (Fig 2). This arrangement had not served three basic functions of the decking plates.

- 1 Spillage loads should be carried out safely.
- 2 Deflection at centre should be within limits of span/325.
- 3 Workman may stand over the decking plate (during pulling of the belt over idlers, aligning of the belt conveyor etc.)

Under these conditions, efforts were mooted at ELECON to review the basic design approach, economics, performance, O&M convenience etc. And outcome is simple cold formed decking plate design as depicted in Fig 3. Normally the carrying idler spacing is 1200mm in many projects. Half of this spacing i.e. 600mm was selected as formed width (nominal). The decking plates would be fixed to Conveyor Stringer by bolts. The shape is selected with a view to stack one another and to make compact consignment in transport thereby avoiding damage to these thin sections. To provide idler base a total resting on conveyor stringer, the plate is notched as shown in Fig 4. Drilling and such notching is carried out at site. This permitted the concept of cold roll forming to be effectively utilised in mass production very quickly. Earlier, such cross section was also tried out using Press-brake which delayed the deliveries and entailed heavy wastage from sides and ends, while in cold roll forming coil of exact width can be selected and for length, exactly cuts can be made after rolling is completed. This means virtually zero wastage in cold roll forming. Moreover, the product remained uniform and stable in dimensions, shape and tolerances.

Load carrying capacities for 2mm and 3.15mm thick decking plates for different spans have been shown in Fig 5.

This concept of decking plate has been tried out successfully in Nasik, Mettur, Parli and Gandhinagar TPS (Fig 6). Various ongoing projects also utilise these decking plates.

BOTTOM COVER PLATES

These plates are provided below return belt with a view to protect people moving underneath, from falling spillage with considerable energy,

In certain projects, bottom cover plates (also known as seal plates) are provided throughout for all conveyors. Elsewhere these are specified to be provided at rail/road crossings, any buildings, equipments etc.

The basic functions of these plates, which are usually 3.15mm in thickness, are identical to decking plates.

At ELECON, having changed the design for the decking plates, bottom cover plates (of identical cross-section to decking plates) are provided, at many projects.

Typical application has been depicted in Fig 7.

CONVEYORS STRINGERS

Belt conveyors are supported on carrying idlers (which are two piece or three piece troughing idler set) and on return side on return idlers (which are one piece normally, but in certain cases two piece garland type idlers are provided).

Since conveyor stands are provided at 3.0m intervals, conveyor stringers span normally at this distance.

Conveyor stringers so far provided are either hot rolled ISMC or hot rolled unequal angle sections.

At ELECON, even Z Section (CRFS) which is generally used in Purlins, have been used successfully in one of MH Projects (Fig 8).

Cold roll formed channel section is ideally suited for conveyor stringer. This has been also used in one of the underground mine conveyors with quite a success.

CONCLUSIONS

- 1 It has been observed that cold roll framed sections have been found economical as exact cut lengths can be ordered. Further fabrication costs are much reduced as only drilling of holes are involved, at site.
- 2 If the product is standardised (such as decking plate), delivery can be made much faster.
- 3 High premiums to be paid in procuring certain hot rolled sections (such as unequal angles, channels) are avoided with CRFS.
- 4 CRFS can be planned to procure Just-in-Time(JIT), while hot rolled sections are to be procured much in advance because of erratic & uncertain supply conditions.
- 5 With hot rolled sections, cash flow is adversely affected because of huge inventory to be carried for longer period. For CRFS payments can be made on or after receipt of sections at site/works.
- 6 Transportation costs for CRFS are minimum as bulking is avoided (which is usual feature for hot roll formed sections) as CRFS sections are designed for easy stack-ability & bundling to occupy most compact space.
- 7 Particularly Material Handling Industry works lot more on standardisation of such components; cost & time for design engineering can be saved.
- 8 Walkway runners, side sheeting runners (girts), purlins are also potential structural elements for using CRFS sections.

REFERENCES

- 1 IS:800.1984, Indian Standard Code of Practice for General Construction in Steel(Second Revision), Indian Standards Institution, New Delhi, Feb. 1985.
- 2 IS:11592.1985, Indian Standard Code of Practice for section & Design of Belt Conveyors, Indian Standards Institution, New Delhi, Dec.1986.
- 3 Cold-Formed Steel Design Manual, American Iron & Steel Institute, USA, 1983.

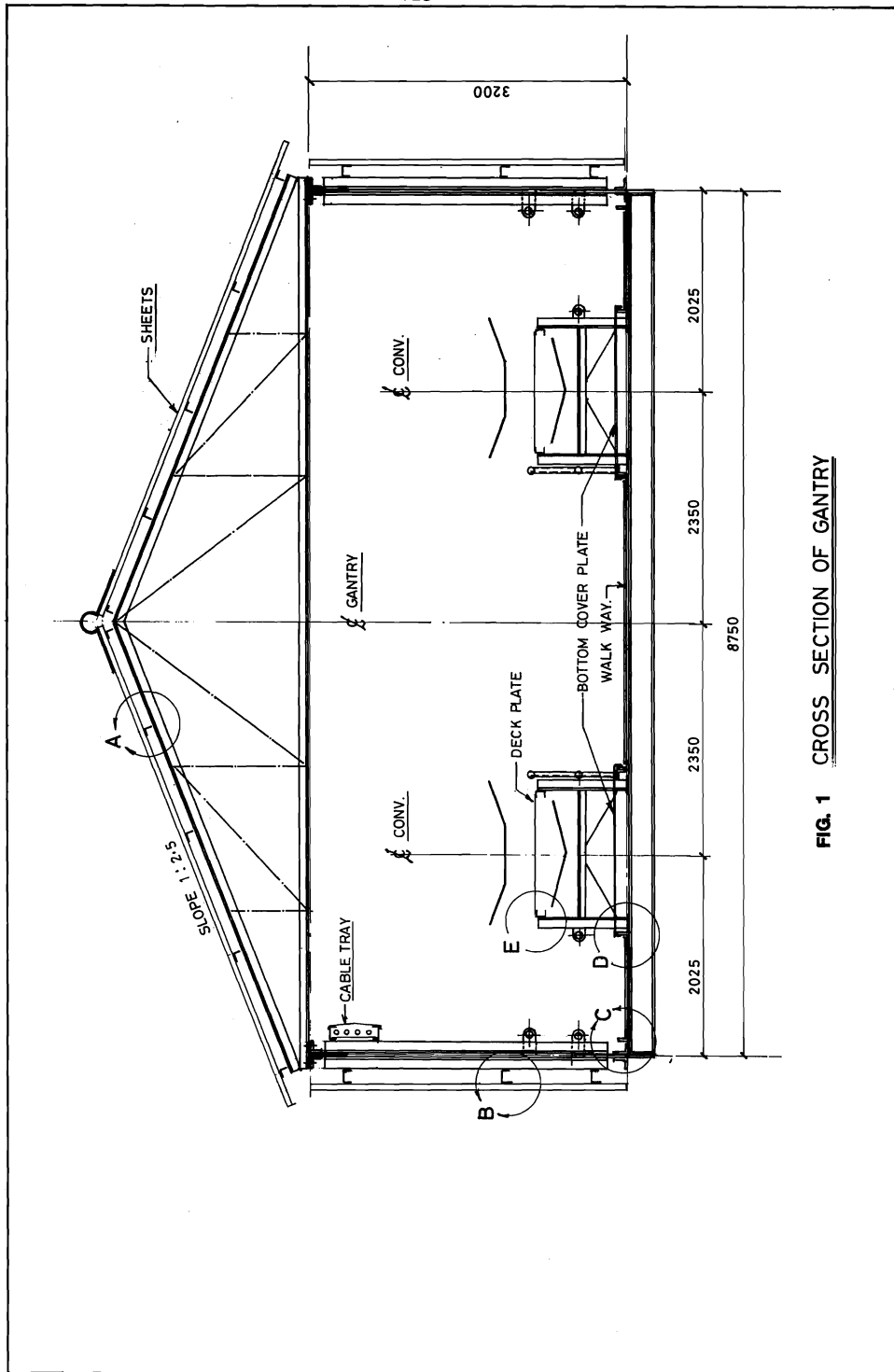

FIG. 1 CROSS SECTION OF GANTRY

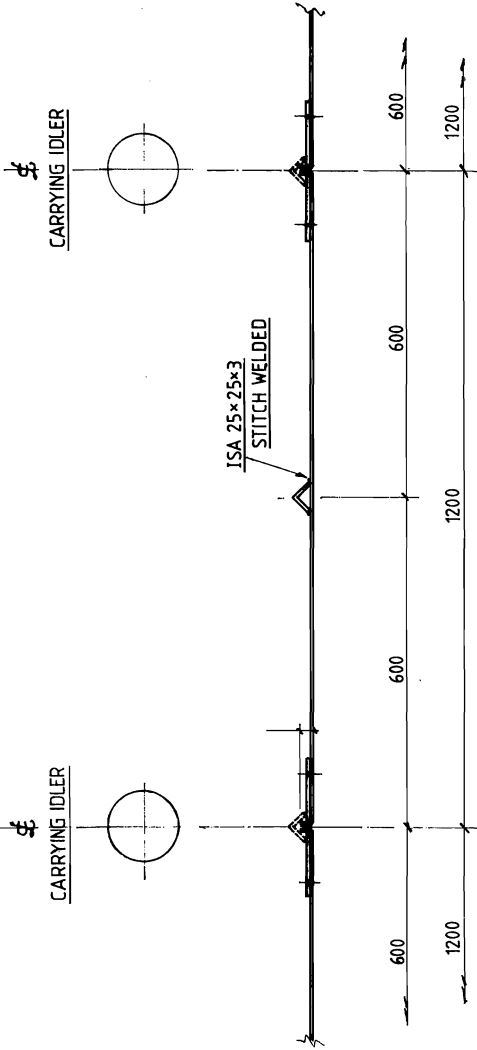
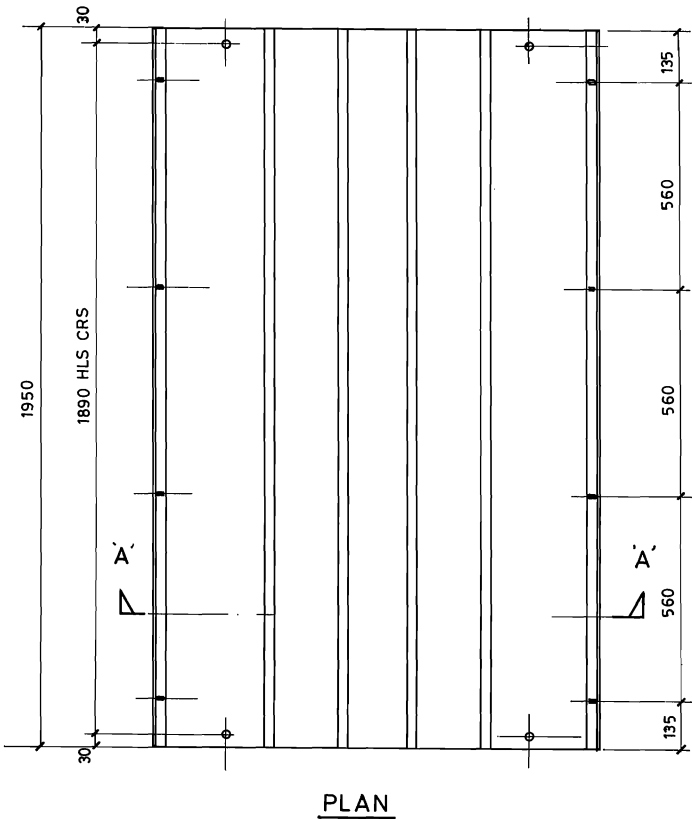
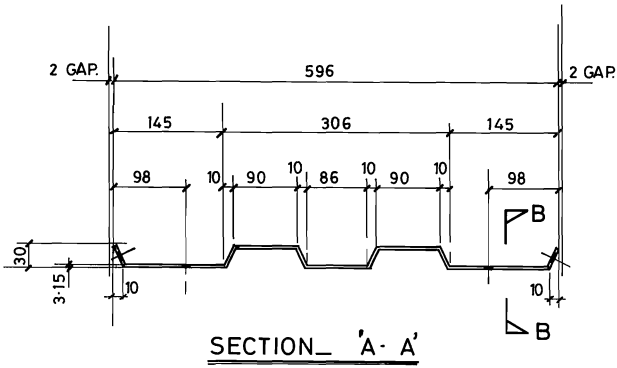

FIG. 2 CONVENTIONAL DECKING PLATE BY WELDING AN ANGLE AND BENDING EDGES.



HEX. SCREW M 8 X 25 LG. IS: 1363
 HEX. NUT. M 8. IS: 1363
 PLAIN WASHER A10 IS: 2016

FINISHED SIZE: 3-15thk.x596x1950 lg.
 APPROX. WEIGHT. 34 KGS / PIECE

FIG. 3 DETAILS OF DECKING PLATE

- ALL DIMENSIONS ARE IN MM

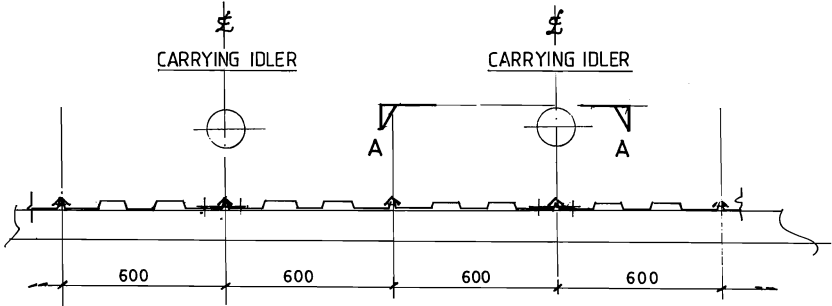

ELEVATION

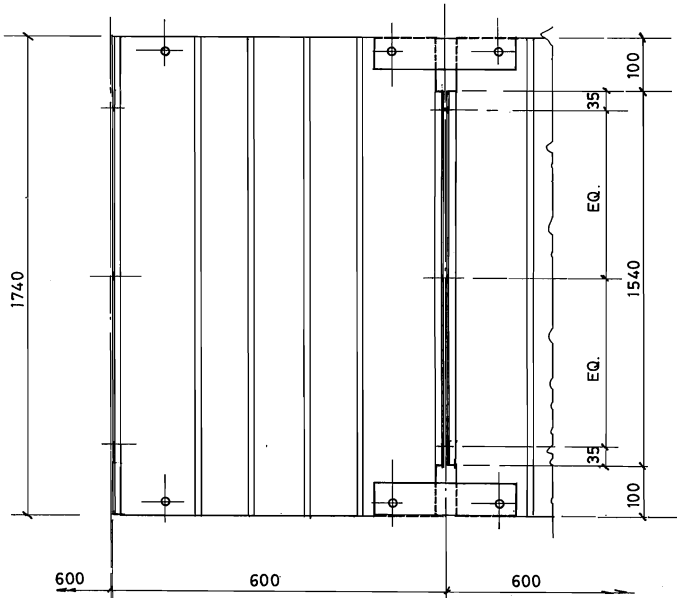

PLAN ON 'A-A'

FIG. 4 NOTCHING IN DECKING PLATE
FOR IDLER SITTING

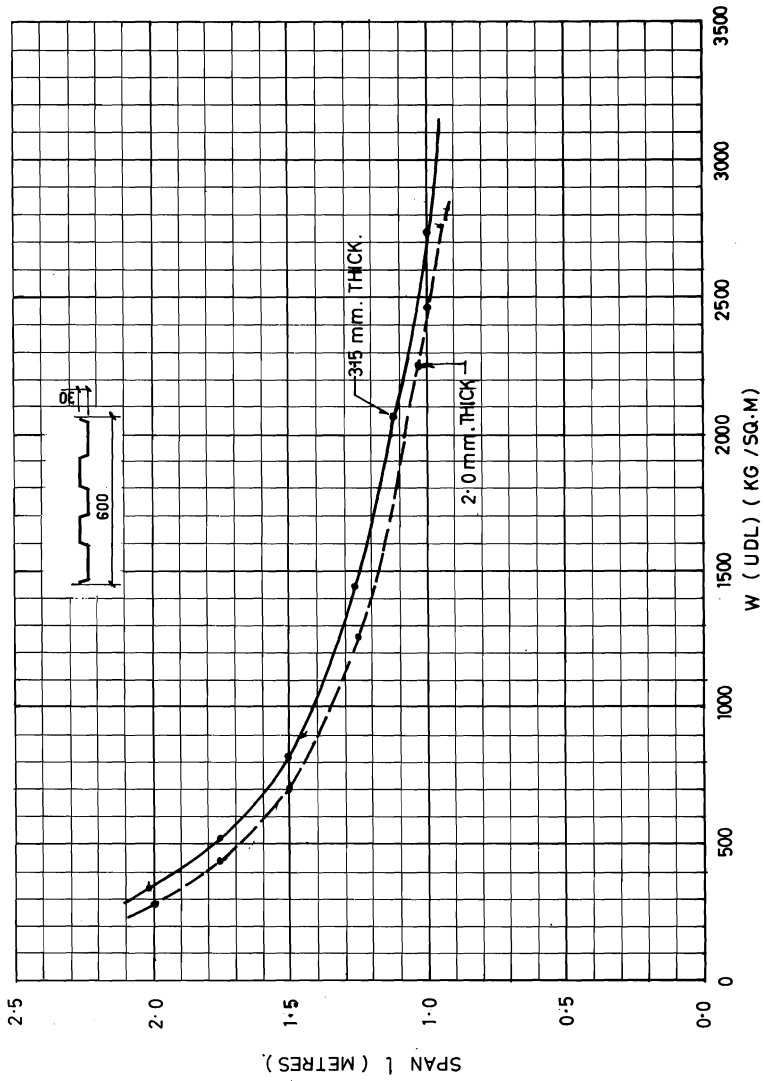

FIG. 6 SAFE LOADS ON CRFS DECKING PLATE

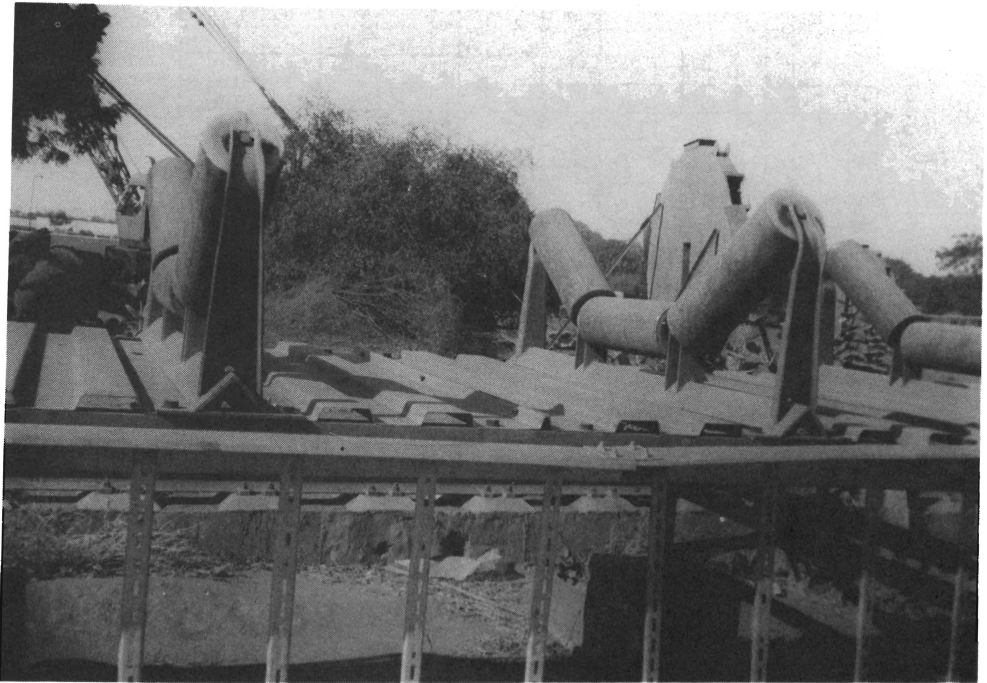

Fig. 6 **Decking Plates installed at Gandhinagar TPS/CHP**

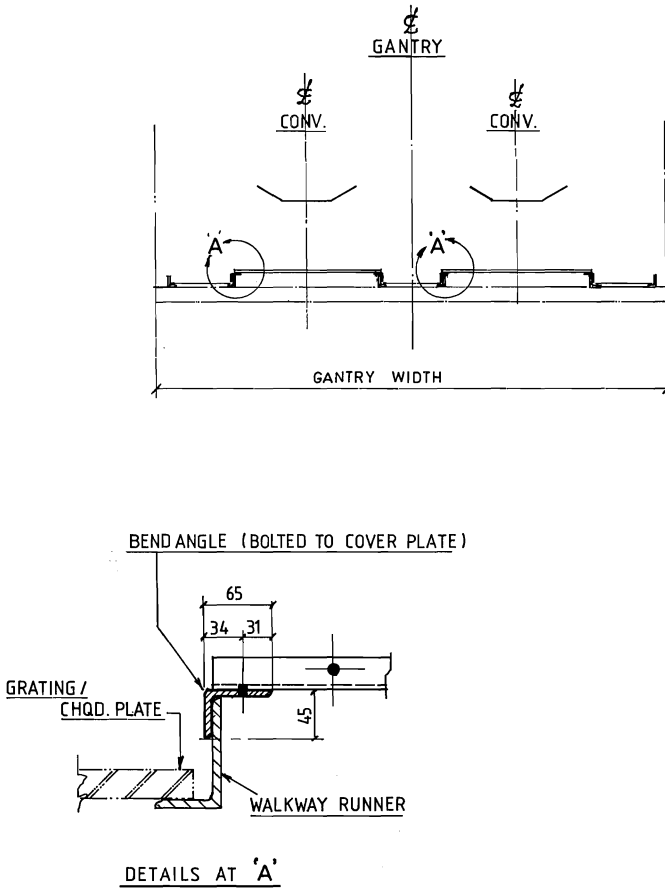

FIG. 7 COLD ROLL FORMED BOTTOM COVER PLATE.

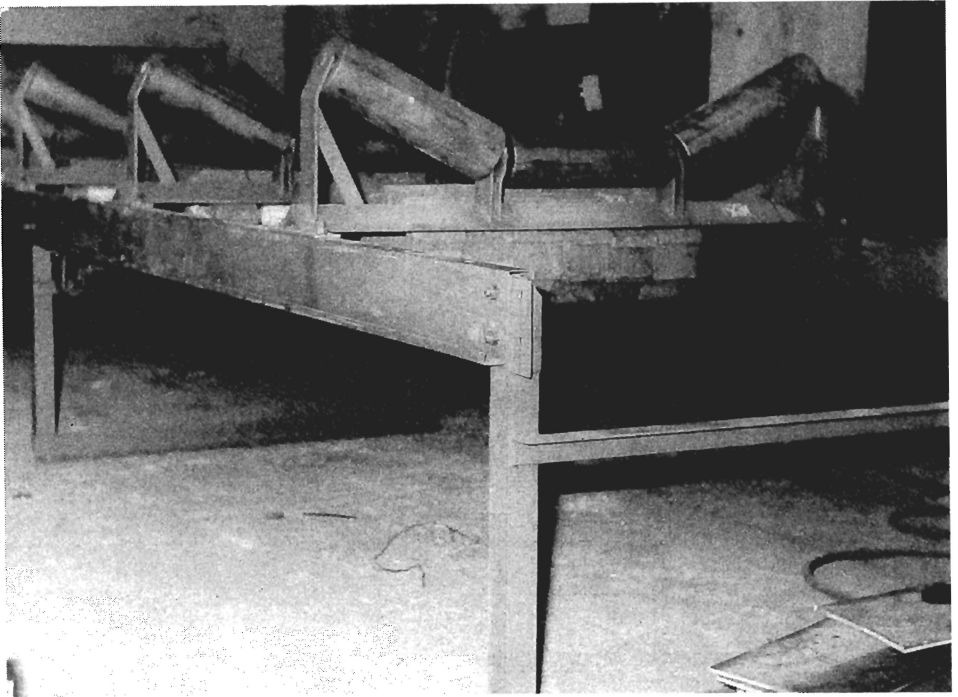

Fig.8 Conveyor stringers: Z Section under prototype testing. Loads applied using crusher hammer rings