



Missouri University of Science and Technology
Scholars' Mine

International Specialty Conference on Cold-Formed Steel Structures

(1975) - 3rd International Specialty Conference on Cold-Formed Steel Structures

Nov 24th, 12:00 AM

Blast-resistant Design of Cold-formed Steel Panels

Albert R. Ammar

George S. Tseng

John J. Healey

Follow this and additional works at: <https://scholarsmine.mst.edu/isccss>

 Part of the [Structural Engineering Commons](#)

Recommended Citation

Ammar, Albert R.; Tseng, George S.; and Healey, John J., "Blast-resistant Design of Cold-formed Steel Panels" (1975). *International Specialty Conference on Cold-Formed Steel Structures*. 9.
<https://scholarsmine.mst.edu/isccss/3iccfss/3iccfss-session2/9>

This Article - Conference proceedings is brought to you for free and open access by Scholars' Mine. It has been accepted for inclusion in International Specialty Conference on Cold-Formed Steel Structures by an authorized administrator of Scholars' Mine. This work is protected by U. S. Copyright Law. Unauthorized use including reproduction for redistribution requires the permission of the copyright holder. For more information, please contact scholarsmine@mst.edu.

BLAST-RESISTANT DESIGN OF COLD-FORMED STEEL PANELS

By Albert R. Ammar*, George S. Tseng* and John J. Healey*

INTRODUCTION

Cold-formed steel panels are widely used for roof and floor decking and for wall siding in industrial facilities and pre-engineered buildings. The design of these members for conventional loads is covered by the AISI "Specification for the Design of Cold-Formed Steel Structural Members"(6) and detailed design information is available(2,9). However, when such structures are located within facilities where blast loading due to an accidental explosion must be considered, such as in ammunition plants or chemical plants, additional special design procedures and criteria are necessary. A basic document in the field of blast design is the tri-service manual, "Structures to Resist the Effects of Accidental Explosions"(7). This manual presents the principles of protective design with particular emphasis upon the determination of blast loads and the design of reinforced concrete structural elements. In order to provide facility designers with parallel information on steel design, Ammann & Whitney, Consulting Engineers, has prepared two related reports on blast design of steel structures(4,8) under contract to the Manufacturing Technology Directorate of Picatinny Arsenal as part of the overall Safety Engineering Support Program for the U.S. Army Armament Command. The information presented in this paper is based on material developed as a part of that effort.

Practical blast design procedures are described for utilizing the energy absorption capabilities of simply-supported and continuous panels in protective structures removed from the location of the Blast and subjected to low to inter-

*Structural Engineer, Ammann & Whitney, Consulting Engineers, New York, N.Y.

mediate pressures up to about 12 psi. The objective is to provide protection for personnel and equipment and, in some cases, to provide a structural element which may be reused following the blast.

GENERAL APPROACH

The economy of blast design generally requires that protective structures be designed to perform in the inelastic range. The limiting values of these inelastic deformations are dependent upon the ductility characteristics of the structural element and upon the intended use of the structure following the blast. The design procedure consists essentially of determining the structural resistance required to limit the computed dynamic deflection to within these prescribed maximum values. The resistance and deflection are computed on the basis of flexural considerations with separate checks on the integrity of the panel sections with respect to shear and web crippling.

As opposed to structures located close-in to the detonation where the design is generally impulse sensitive, these designs are characteristically governed by the blast pressure-time relationship or by the blast pressure level only, due to the relatively long duration of the blast at the pressure range of interest. In either case, the response is obtained from dynamic response charts for a single-degree-of-freedom system wherein the structural element is characterized by a bilinear elasto-plastic resistance function and the load is treated as an idealized triangular pressure pulse with zero rise-time, as shown in Figure 1. The standard procedures in Chapter 4 of Reference 7 are used to determine the peak pressure, B , and the load duration, T , corresponding to the explosive charge weight (TNT equivalent) and the location of the structure with respect to the detonation.

The influence of conventional dead and live loads can usually be neglected in blast design or in the evaluation of the capacity of a blast-resistant structure. However, the effect of such loads upon the available capacity for blast resistance may be significant in the design of structures for relatively low overpressures, e.g., less than 1.0 psi or in the evaluation of the blast resistance of a structure designed for conventional loads.

DYNAMIC FLEXURAL BEHAVIOR OF COLD-FORMED PANELS

Inelastic Behavior - It has been well established that hot-rolled structural shapes possess sufficient plastic rotation capability and ductility to justify the application of plastic design techniques including the successive development of plastic hinges and moment redistribution in continuous structures. Normal plastic design concepts are not directly applicable to cold-formed members since the width-thickness and/or the depth-thickness ratios are generally greater than the limits required for plastic hinge formation and development; and, in most practical cases, local inelastic buckling of flanges or webs occurs prior to full plastification of the cross-section.

While it is recognized that cold-formed sections possess some inelastic reserve strength, the amount of experimental data is quite limited on the ultimate moment capacity, the available ductility before failure and the extent of moment redistribution in a continuous member. Research has been conducted at Cornell University(5) on the inelastic behavior of cold-formed beams with stiffened flanges. These results indicate that, depending upon the width-thickness ratio of the compression flange and upon the section geometry (position of the neutral axis), increases in maximum moment of up to 30 percent above the yield moment can be achieved. This partial plastification, together with rotation

capability beyond first yielding, indicates the capability of these sections for limited moment redistribution and the ability to respond to deformations beyond yield without complete collapse.

An effort has been made to develop relatively simple guidelines for inelastic blast design which are applicable to a wide class of available panel sections and with sufficient flexibility to treat sections which respond significantly in both directions due to the initial response and subsequent rebound. Therefore, in order to reduce to a minimum the restrictions on panel geometry, no account has been taken of the increase in moment capacity beyond the yield moment. Where necessary, conservative estimates have been made based upon available data, e.g., regarding the available ductility and the extent of moment redistribution in continuous members. The resulting representation of panel behavior provides a consistent basis for a reliable design formulation.

Resistance and Response Characteristics - The load-deflection characteristics of cold-formed panels with either an open hat section or a hat section closed with a flat sheet are shown schematically in Figure 2. The curves are markedly nonlinear due to local buckling effects. As implemented in the AISI Design Specification, the effective width concept is used to account for the post-buckling strength of stiffened compression flanges and, hence, to determine the nonlinear variation of the section properties with load intensity. As indicated in Figure 2, the amount of inelastic deformation that a specific section can develop after reaching its maximum resistance depends upon the width-thickness ratio of the compression flanges. For values of $w/t \geq 40$, the behavior is "ductile" and strains several times the yield strain are developed before failure. For large w/t values and especially for $w/t > 60$, the load-carrying capacity may

be reduced abruptly upon yielding of the most stressed outer fiber. For an open cross-section, the descending curve is unstable in nature; whereas for a closed section, the decrease is more gradual, and a certain amount of reserve energy absorption capacity can be developed corresponding to membrane action of the flat sheet. For this reason, and for rebound considerations, it is recommended that only the closed panel cross-section be used in blast-resistant structures.

Recent studies(10) have shown that the effective width relationships for cold-formed elements under dynamic loading do not differ significantly from the static relationships. Hence, the standard w/t equations(6) and tabulated section properties for cold-formed sections can be used to define the strength and stiffness properties of dynamically-loaded sections.

It has been established(3) that the increased strain rates in blast-loaded structures cause a definite increase in the yield point. For the type of steel generally used in cold-formed panels and for the range of loading rates anticipated for these elements, it is recommended that a dynamic increase factor of 1.1 be applied in calculating the dynamic yield point stress, F_{dy} , i.e.,

$$F_{dy} = 1.1F_y \quad (1)$$

and hence, F_{dy} equals 36.3 ksi for the usual case of a 33-ksi steel.

The tabulated section properties of panels, as provided by the manufacturers, are related to different stress levels; the tabulated moment of inertia is related to a service stress level of 20 ksi and the section modulus is related to the effective cross-section when the yield stress is reached in an extreme fiber. For closed panels composed of a hat section and a flat sheet,

two section moduli are necessary, S^+ and S^- , referring to the effective section moduli for positive and negative moments, respectively. Since in this design approach, partial web plastification is not taken into account in calculating the maximum moment developed in the section, the following general expressions for the ultimate moment capacities are obtained:

$$M_{UP} = F_{dy}S^+ \quad (2)$$

$$M_{UN} = F_{dy}S^- \quad (3)$$

where M_{UP} and M_{UN} are the ultimate positive and negative moment capacities for a one-foot width of panel, respectively.

The maximum resistance developed in a panel section is dependent upon the particular end conditions and upon the extent of moment redistribution for continuous members. Due to the limited ductility of cold-formed elements, partial moment redistribution is considered, similar to reinforced concrete design, i.e., starting with the elastic moment distribution, the maximum negative moments at the supports are reduced and the in-span positive moments are increased. A reduction of 15 percent in the negative moment at the inner support of a two-equal-span continuous panel is recommended compared to a 10 percent moment reduction at the inner support of a multi-span continuous panel. In order to simplify the application of these procedures for design and for computer calculations, three typical end condition cases were considered: (1) simply supported at both ends (single span); (2) simply supported at one end and fixed at the other (two-equal-span continuous member); and (3) simply supported at one end and partially fixed at the other (first span of an equally-spaced, multi-span member). With the recommended moment redistribution, the computed maximum resistances for two-span and multi-span panels become quite close to one another, and for simplicity,

average values may be used to cover both cases. Consequently, the following resistance formulas are obtained:

Simply-supported, single-span panel

$$r_u = (8.0M_{uP})/L^2 \quad (4)$$

Simple-fixed, single-span panel or first span of an equally-spaced continuous panel

$$r_u = (12.2M_{uP})/L^2 \quad (5a)$$

$$\text{or, } r_u = (10.1M_{uN})/L^2 \quad (5b)$$

where r_u is the resistance per unit length of the panel.

Figure 3 illustrates the nonlinear character of the resistance-deflection curve and the suggested bilinear approximation. The equivalent elastic deflection, χ_E , is defined by the following equation:

$$\chi_E = (\beta r_u L^4)/EI_{eq} \quad (6)$$

where β is a constant depending upon the support condition, as follows:

$$\beta = 0.0130 \text{ for simply-supported elements}$$

$$\beta = 0.0062, \text{ an average deflection coefficient for simple-fixed, or continuous elements, and}$$

$$I_{eq} = 0.75I_{20}$$

where I_{eq} is a moment of inertia value adjusted for average conditions such that the area under the idealized resistance diagram is equal to the area under the actual diagram up to the development of the maximum resistance, r_u . The value

I_{20} , the effective moment of inertia of the section at a service stress of 20 ksi, is generally tabulated as a section property of the panel.

In Figure 3, X_1 is defined as the deflection at the development of the maximum resistance and X_u is the ultimate deflection after the drop in load-carrying capacity. Based on evidence from load-deflection curves for panels, the ratio of X_1/X_E is estimated to range between 2.0 and 2.5. The amount of inelastic deformation which is permitted in design will vary in magnitude depending on the desired post-accident condition of the panel.

When performing a one-degree-of-freedom analysis of the panel's behavior, the properties of the equivalent system can be evaluated by using a load-mass factor, $K_{LM} = 0.74$, which is an average value applicable to all support conditions. The natural period of vibration for the equivalent single-degree system is thus obtained by

$$T_N = 2\pi\sqrt{0.74mL/K_E} \quad (7)$$

where $m = w/g$ is the unit mass of the panel and $K_E = r_uL/X_E$ is the equivalent elastic stiffness of the system.

Design Criteria - As stated previously, the basic design requirement for these structural elements in acceptor structures is to provide protection to personnel and equipment, while responding in a ductile manner to controlled inelastic deflections. The deformation criteria are specified for two different design categories based upon the anticipated post-accident condition of the element. Structures in the first category, "reusable" structures, are intended to sustain light damage such that they are reusable with only minor repair. Permanent deformations can be tolerated to the extent that they are compatible with future

structural safety and with the intended function of the building, including any manufacturing operations which interface with the structure. The second category includes structures designed to provide safety and structural integrity during the accident but permitted to sustain moderate to severe damage. In this case, however, the damage is such that the post-accident condition is not compatible with future structural safety and the damage is such that the repair work necessary to restore the structure would be excessive. Such structures are, therefore, "non-reusable".

In order to restrict the amount of damage, limiting values are assigned to two different response quantities for a single-degree-of-freedom system such as a panel; namely, limits on the level of inelastic dynamic response specified in terms of the ductility ratio, and limits on the absolute magnitude of the deflection specified in terms of the maximum support rotation. The ductility ratio, μ , is defined as the ratio of the maximum deflection (X_m) to the equivalent elastic deflection (X_E). Thus, a μ of 2 corresponds to a maximum dynamic response twice the equivalent elastic response. The rotation, θ , at an end support is the angle between the chord joining the member ends and the chord joining the support and the point on the element where the deflection is a maximum.

The following design ductility ratios are recommended for cold-formed panels (see Figure 3):

$$\mu_{\max} = (X_m)_r / X_E = 1.25 \text{ for reusable panels, and}$$

$$\mu_{\max} = (X_m)_n / X = 1.75 \text{ for non-reusable panels}$$

The maximum displacements are kept below the deflection corresponding to the maximum resistance in order to prevent any critical impairment to the element. The area beyond $(X_m)_n$ and the area under the descending curve, up to the complete loss of carrying capacity constitute a reserve capacity for energy absorption and a safeguard against total collapse.

In addition, in order to restrict the magnitude of rotation at the supports, limitations are placed on the maximum deflections, namely:

$$(X_m)_r = L/130 \text{ or } \theta_{\max} \approx 0.9^\circ$$

$$(X_m)_n = L/65 \text{ or } \theta_{\max} \approx 1.8^\circ$$

for reusable and non-reusable elements, respectively.

Due to the limited amount of experimental data available on the performance of cold-formed elements in the inelastic range, the overall level of confidence in the inelastic design of this type of element is lower than that of hot-rolled sections. Rather than alter the basic design criteria on this count, it is recommended that the peak blast pressure from Reference 7 be increased by 10 percent for the design of these panels, until further experimental data are accumulated on their dynamic load-carrying characteristics.

Rebound - The problem of rebound must be given special consideration in the design of cold-formed panels due to the different section properties of the panel depending on whether the hat section or the flat sheet is in compression. Figure 4 can be used to determine, as a function of μ and T/T_N , the resistance in rebound, \bar{r} , which is required in order to keep the section elastic in rebound. In the practical design range, T/T_N is generally larger than 1.0, and hence, the required elastic resistance in rebound will be less than $0.7r_u$. Most decks have

section properties that will provide an elastic resistance in rebound at least equal to this value. In the event that the actual resistance in rebound is less than that required from Figure 4, another panel section would normally be selected in order to obviate the consideration of plastic behavior in rebound.

DESIGN PROCEDURES

Flexural Response - For the preliminary design of panels for structures located in the low to intermediate pressure range, a trial panel can be determined on the basis of an equivalent static load equal to 1.65 and 1.4 times the peak blast forces for reusable and non-reusable structures, respectively. These equivalent static loads are based on the fact that the load duration for these pressure ranges will generally be the same or longer than the period of vibration of the element and the design ductility ratio ranges from 1.25 to 1.75. Hence, revisions to this preliminary design should not be substantial. Having selected a panel which meets the section modulus requirements corresponding to this estimated response, the actual dynamic response of the member to the given pressure-time load is determined based on the panel resistance and stiffness properties given above, and using the elasto-plastic chart in Figure 5. For convenience, Figure 6 shows the corresponding response charts for a system which remains elastic.

The maximum ductility ratio and the corresponding maximum end rotation are then compared with the design criteria presented previously. If these requirements are met, the remaining flexural consideration is the response in rebound. As described above, this involves comparing the available resistance in the rebound direction to the required resistance for elastic rebound, as determined from Figure 4.

Web Capacity - In considering the capacity of the webs of cold-formed steel members versus buckling and crippling effects, the designer is faced with somewhat different problems from those encountered in hot-rolled members since webs with h/t values in excess of 60 are common and, at the same time, the fabrication process makes it impractical to use stiffeners. The design web stresses must therefore be limited to insure adequate stability without the aid of stiffeners, thereby preventing premature local web failure and the accompanying loss of load-carrying capacity.

The possibility of web buckling due to bending stresses exists and the the critical bending stress is given by

$$F_{cr} = 640,000/(h/t)^2 \leq F_y \quad (8)$$

Equating F_{cr} to 32 ksi (a stress close to the yielding of the material), a value of $h/t = 141$ is obtained. Since it is known that webs do not actually fail at these theoretical buckling stresses due to the development of post buckling strength, it can be safely assumed that webs with $h/t \leq 150$ will not be susceptible to flexural buckling. Moreover, since the AISI recommendations prescribe a limit of $h/t = 150$ for unstiffened webs, this type of web instability need not be considered in design.

Panels are generally manufactured in geometrical proportions which preclude web-shear problems when used for recommended spans and minimum support-bearing lengths of 2 to 3 inches. In blast design, however, because of the greater intensity of the loading, the increase in required flexural resistance of the panels calls for shorter spans. As a result, the problem of shear resistance is magnified and requires special treatment.

In most cases, the shear capacity of a web is dictated by instability due to either simple shear stress, or combined bending and shearing stresses. For the case of simple shear stresses, as encountered at an end support, it is important to distinguish three ranges of behavior depending on the magnitude of h/t . For large values of h/t , the maximum shear is dictated by the elastic buckling in shear; for intermediate h/t values, the inelastic buckling of the webs governs; whereas for very small values of h/t , local buckling will not occur and failure will be caused by yielding produced by shear stresses. The provisions of the AISI Specification(6) in this area are based on a safety factor ranging from 1.44 to 1.67 depending upon h/t . For blast-resistant design, the recommended maximum design stresses for simple shear are based on an extension of the AISI provisions to comply with ultimate load conditions. The specific equations for use in design are summarized in Table 1 for steel with $F_y = 33$ ksi.

At the interior supports of continuous panels, high bending moments combine with large shear forces, and webs must be checked for buckling due to combined bending and shear. The interaction formula presented in the AISI Specification is given in terms of allowable stresses rather than critical stresses which produce buckling. In order to adapt this interaction formula to ultimate load conditions, the problem of inelastic buckling under combined stresses has been considered following the procedure outlined by Bleich(1). In order to minimize the amount and complexity of design calculations, the requirements for safety versus failure due to combined bending and shear have been simplified to a restriction on the shear stress. These limiting values on the dynamic design shear stress F_{dv} are presented for a range of h/t ratios in Table 1.

In addition to shear problems, concentrated loads or reactions at panel supports, applied over relatively short lengths, can produce load intensities

that can cripple unstiffened thin webs. As stated in the Commentary of the AISI Specification, a theoretical analysis of the phenomenon of web crippling is extremely complex since it involves elastic and inelastic instability under non-uniform stress distribution, combined with local yielding in the immediate region of load application. The AISI recommendations have been developed by relating extensive experimental data to service loads with a safety factor of 2.2 which was established taking into account the scatter in the data. For blast design of cold-formed panels, it is recommended that the AISI values be multiplied by a factor of 1.50 in order to relate the crippling loads to ultimate conditions considering the variations in test results.

Since it has been recommended that closed section panels (flat sheet and hat sections) be used, only those equations pertaining to webs restrained from rotation will be considered. Using a yield stress of 33.0 ksi and the factor of 1.50 mentioned above, the ultimate crippling loads are given as follows:

Acceptable ultimate end support reaction,

$$Q_u = 49.5t^2(4.44 + 0.558\sqrt{N/t}) \quad (9)$$

Acceptable ultimate interior support reaction,

$$Q_u = 49.5t^2(6.66 + 1.446\sqrt{N/t}) \quad (10)$$

where Q_u is the ultimate support reaction, N is the bearing length and t is the web thickness.

In design, the maximum shear forces and dynamic reactions are computed as a function of the maximum resistance in flexure. The ultimate load-carrying capacity of the webs of the panel must then be compared with these forces. In general, the shear capacity is controlled by simple shear buckling or web crippling

for simply-supported elements and by the allowable design shear stresses at the interior supports for continuous panels.

In addition, it can be shown that the resistance in shear governs only in cases of relatively short spans. If a design is controlled by shear resistance, it is recommended that another panel be selected since a flexural failure mode is generally preferred.

Connections - In blast design, panel-to-panel or panel-to-supporting-member connections are made with conventional connectors including self-tapping screws, puddle welds, washer plug welds, threaded connectors fired into the elements to be attached, or bolted connections. However, the dynamic design stresses for connectors are taken equal to 1.87 times the conventional allowable stresses. This factor is based on eliminating the safety factor of 1.7 and includes a dynamic increase factor of 1.1.

Unless it is shown by analysis that the resistance developed in rebound is less than r_u , connections should be designed for pull-out forces corresponding to the full resistance.

Even for conventional design and normal wind loading, commonly used screw fasteners have often been the source of local failure by tearing the sheeting material. Under blast loading and particularly on rebound, screw connectors are even more vulnerable to failure of this type. The likelihood of failure can be reduced by using oversized washers and/or by increasing the material thickness at the connection.

DESIGN CHARTS

In order to assist designers in the selection of steel panels for use in blast-resistant structures, design charts have been developed for typical panel sections. A total of 60 charts are presented in Reference 8 for single-span and multiple-span panels covering a range of spans from 3 to 10 feet at 0.5-ft intervals. The blast loading consists of a triangular pressure pulse with peak overpressures up to 12 psi and duration times ranging from 20 to 400 milliseconds. A range of panel sizes are included for several different cross-section types. The panel cross-sections for two of these types are shown in Figure 7 and the section properties are listed in Table 2. The charts are presented for both the reusable and non-reusable design categories.

The charts were developed by computer calculations in accordance with the criteria and procedures of Reference 4. The computations consisted of a series of iterative numerical integrations of the response equation for an elasto-plastic, single-degree-of-freedom system.

Some typical design charts are presented in Figures 8 and 9 to illustrate the content and practical application of the charts. For example, in the design of a non-reusable single-span, simply-supported panel with a 4-ft span for a peak overpressure of 3.5 psi and a duration time of 100 milliseconds, Figure 8 indicates that a Type 1 (18-18) panel, as defined in Figure 7 and Table 2, will satisfy the design requirements.

TEST PROGRAM

Explosive tests will be performed in the near future on a series of typical cold-formed steel panels as part of an overall test program being conducted by

Picatinny Arsenal to evaluate the performance of various structural elements and systems used in protective design.

The purpose of the panel tests is to verify, further develop and extend the inelastic blast design procedures for cold-formed panels. The behavior of various single- and multiple-span panels with both open and closed cross-sections will be observed under blast overpressures ranging from 1 to 6 psi with load durations on the order of 50 ms. Several types of panel connectors are being used including puddle welds, bolted connections and self-tapping screws.

The panel tests will be conducted at the U.S. Army Dugway Proving Ground, Utah. A photograph of one of the support structures designed to accommodate both window glass panels and cold-formed steel panels is shown in Figure 10. A multiple-span panel consisting of three equal 5-ft spans will be mounted on the roof, and single-span panels will be attached to the sides of the test structure. Further testing plans include an entire frame structure with steel panels used for both the siding and the roof decking.

CONCLUSIONS

A practical approach has been developed for the blast design of cold-formed steel panels used as decking and siding in protective structures within industrial facilities. The procedures utilize the energy absorption capabilities of single-span and continuous panels subjected to pressure-time loadings with peak overpressures up to about 12 psi. The dynamic nature of the loading is accounted for along with inelastic behavior of the panels including limited ductility and partial moment redistribution. The recommended design criteria consider personnel and equipment safety and the post-accident condition of the panels.

ACKNOWLEDGEMENTS

This paper is based upon material developed by Ammann & Whitney under contract to Picatinny Arsenal, U.S. Army. The authors wish to express their appreciation to the following Picatinny Arsenal personnel under whose direction this work was performed: Messrs. I. Forsten, J. Canavan, P. Price and R. Rindner. Special thanks are also expressed to Messrs. N. Dobbs, G. Pecone and S. Weissman of Ammann & Whitney for guidance provided in the course of the project.

APPENDIX I - REFERENCES

1. Bleich, F., Buckling Strength of Metal Structures, McGraw-Hill, New York, N.Y., 1952.
2. "Cold-Formed Steel Design Manual", American Iron and Steel Institute, Parts II-IV, New York, N.Y., 1971-72.
3. "Design of Structures to Resist the Effects of Atomic Weapons", Department of the Army Technical Manual TM 5-856-2, 3, Washington, D.C., August 1965.
4. Healey, J.J., et al, "Design of Steel Structures to Resist the Effects of HE Explosions", Technical Report 4837, prepared by Ammann & Whitney, Consulting Engineers, New York, N.Y. for Picatinny Arsenal, Dover, N.J. under Contract DAAA 21-74-C-0452, 1975.
5. Reck, J., Pekoz, T. and Winter, G., "Inelastic Reserve Strength of Cold-Formed Steel Beams", Meeting Preprint 2379, ASCE National Meeting, Kansas City, Mo., October 21-25, 1974.
6. Specification for the Design of Cold-Formed Steel Structural Members", and "Commentary" thereon, American Iron and Steel Institute, New York, N.Y., 1968.
7. "Structures to Resist the Effects of Accidental Explosions (with Addenda)", Department of the Army Technical Manual TM 5-1300, Washington, D.C., June 1969.
8. Tseng, G.S., Weissman, S., and Dobbs, N., "Design Charts for Cold-Formed Steel Panels and Wide-Flange Beams Subjected to Blast Loads", Technical Report 4838, prepared by Ammann & Whitney, Consulting Engineers, New York, N.Y., for Picatinny Arsenal, Dover, N.J., under Contract DAAA-21-75-C-0222, 1975.

9. Yu, Wei-Wen, Cold-Formed Steel Structures, McGraw-Hill, New York, N.Y., 1973.
10. Zaroni, E.A. and Culver, C.G., "Impact Loading of Thin-Walled Beams", Proceedings of the First Specialty Conference on Cold-Formed Steel Structures, Department of Civil Engineering, University of Missouri-Rolla, August 19-20, 1971.

APPENDIX II - NOTATION

The following symbols are used in this paper:

B	Peak pressure
E	Modulus of elasticity
F_{cr}	Web buckling stress
F_{dv}	Maximum dynamic shear stress
F_{dy}	Dynamic yield stress
F_y	Static yield stress
g	Acceleration due to gravity
h	Web depth
I_{eq}	Equivalent elastic moment of inertia for panel
I_{20}	Effective panel moment of inertia at a service stress of 20 ksi
K_E	Equivalent elastic stiffness
K_{LM}	Load-mass factor
L	Span length
M_{up}	Ultimate positive moment capacity
M_{uN}	Ultimate negative moment capacity
N	Bearing length at support
Q_u	Ultimate support capacity
\bar{r}	Required unit resistance for elastic behavior in rebound
r_u	Ultimate flexural unit resistance

S^+	Effective section modulus of panel for positive moments
S^-	Effective section modulus of panel for negative moments
T	Load duration
T_N	Natural period of vibration
t	Thickness of plate element
w	Flat width of plate element
X_E	Equivalent elastic deflection
X_m	Maximum deflection
$(X_m)_n$	Maximum deflection, non-reusable panel
$(X_m)_r$	Maximum deflection, reusable panel
X_u	Ultimate deflection
X_γ	Deflection at maximum resistance
β	Deflection coefficient
θ	Member end rotation
μ	Ductility ratio

SUMMARY

This paper presents a practical approach for the blast-resistant design of cold-formed steel panels used as decking and siding within industrial facilities. The procedure accounts for the dynamic nature of the loading and inelastic behavior of the panels.

TABLE 1 - Maximum Dynamic Shear Stresses for Webs
of Cold-Formed Members ($F_y = 33$ ksi)

Simple Shear

$(h/t) \leq 63$	$F_{dv} = 0.50F_{dy} \leq 18.0$ ksi
$63 < (h/t) \leq 93$	$F_{dv} = (190\sqrt{F_{dy}})/(h/t)$ $\approx (1.14 \times 10^3)/(h/t)$
$93 < (h/t) \leq 150$	$F_{dv} \approx (1.07 \times 10^5)/(h/t)^2$

Combined Bending and Shear

<u>(h/t)</u>	<u>F_{dv}(ksi)</u>
20	9.00
30	8.95
40	8.85
50	8.75
60	8.65
70	8.50
80	8.30
90	8.10
100	7.85
110	7.60
120	7.30

TABLE 2 - Section Properties of Cold-Formed Steel Panels
Included in the Design Charts (Reference 8)

Section and Gage*	Weight (psf)	I_{20} (in ⁴)	S^+ (in ³)	S^- (in ³)
Type 1 (20-20)	3.8	0.38	0.31	0.44
Type 1 (18-18)	4.8	0.57	0.47	0.59
Type 1 (16-16)	5.8	0.76	0.64	0.75
Type 1 (14-14)	7.3	1.01	0.89	0.94
Type 1 (12-12)	9.9	1.37	1.35	1.33
Type 2 (20-20)	4.2	1.43	0.60	1.03
Type 2 (18-18)	5.4	2.13	0.91	1.39
Type 2 (16-16)	6.5	2.89	1.26	1.76
Type 2 (14-14)	8.1	3.90	1.75	2.23
Type 2 (12-12)	11.1	6.05	2.83	3.18

*The numbers within each bracket refer to the gage number of the hat section and the flat sheet, respectively.

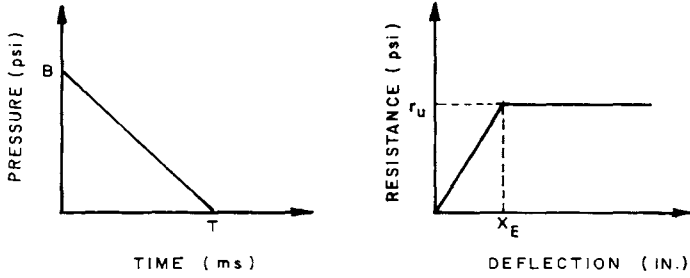

FIG. 1 - Idealized Loading Diagram and Bilinear Resistance Function.

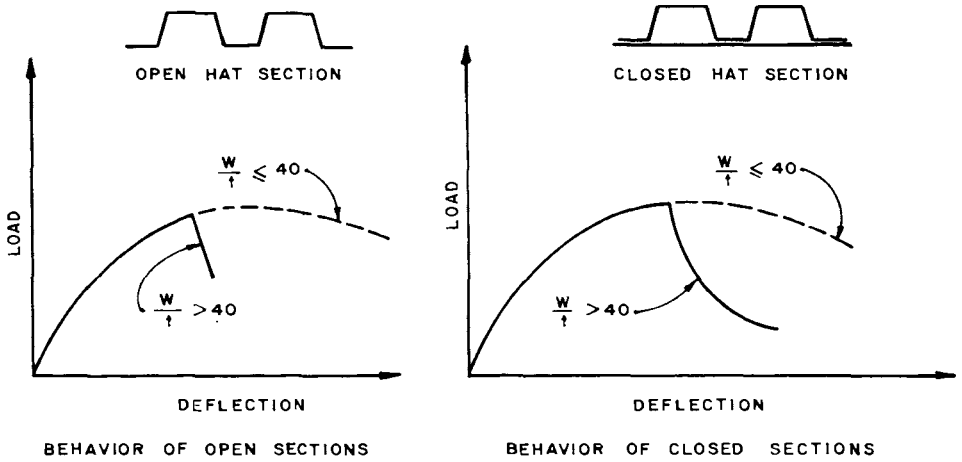

FIG. 2 - Load-Deflection Characteristics of Cold-Formed Panel Sections

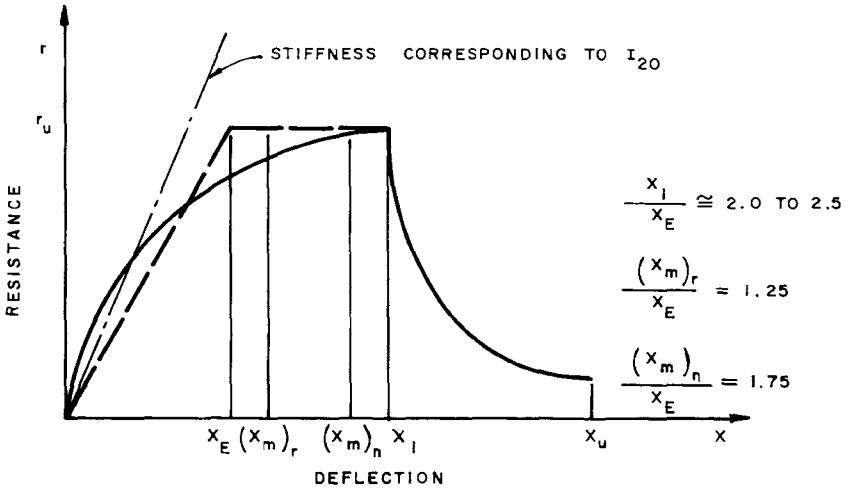

FIG. 3 - Bilinear Approximation of Resistance-Deflection Curve for Closed Sections.

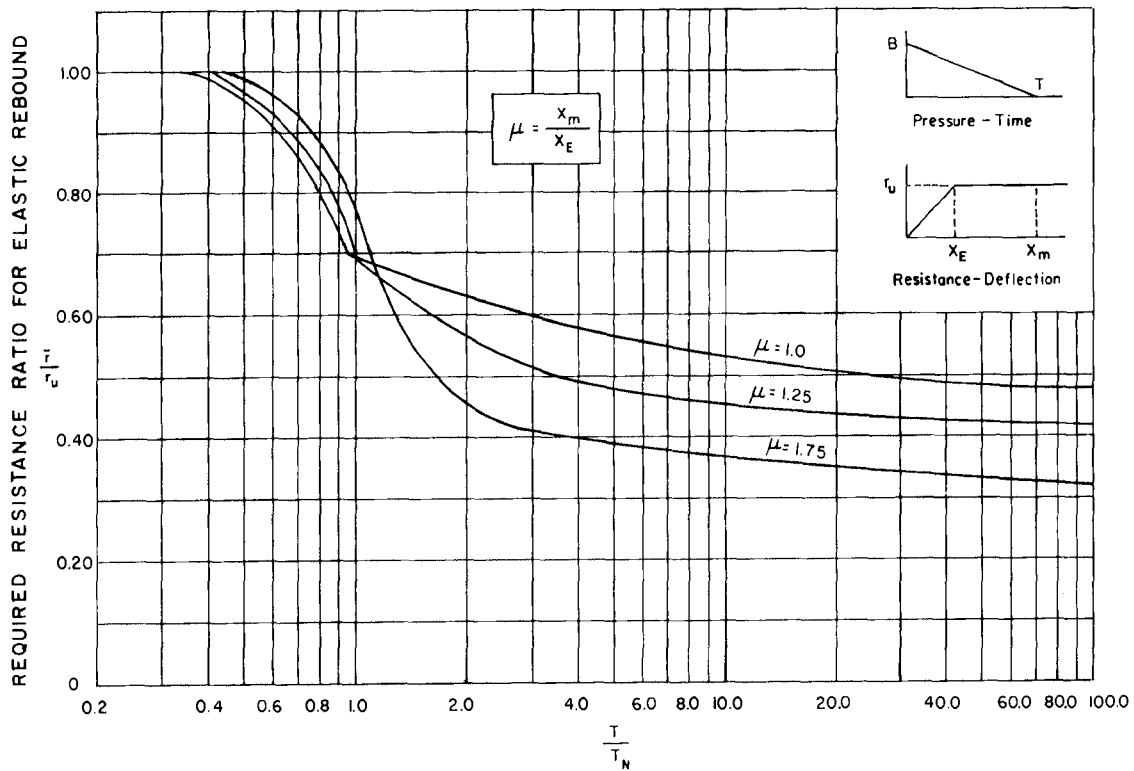

FIG. 4 - Elastic Rebound of Single-Degree-of-Freedom System.

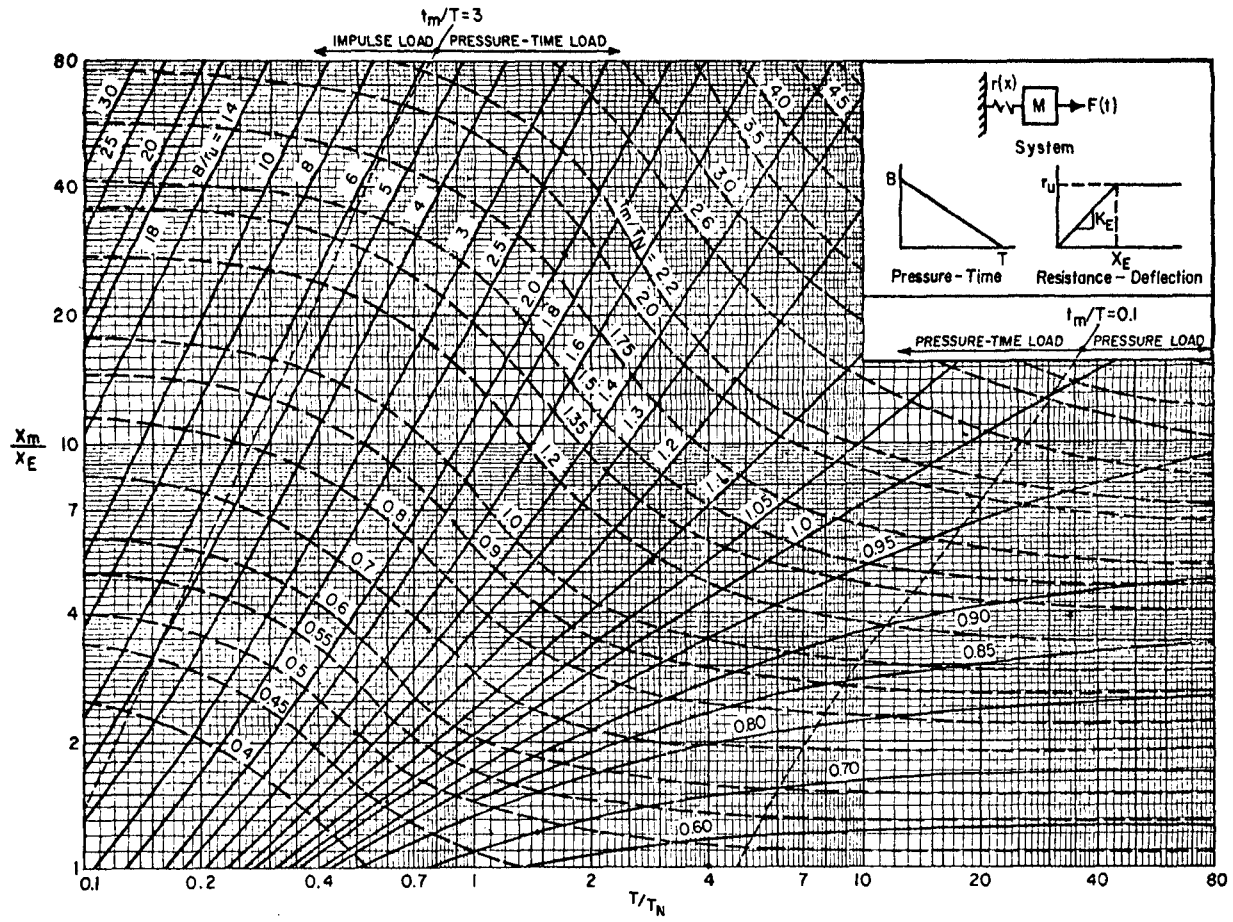

FIG. 5 - Maximum Response of Elasto-Plastic Spring-Mass System to Triangular Load Pulse with Zero Rise Time (Ref. 7).

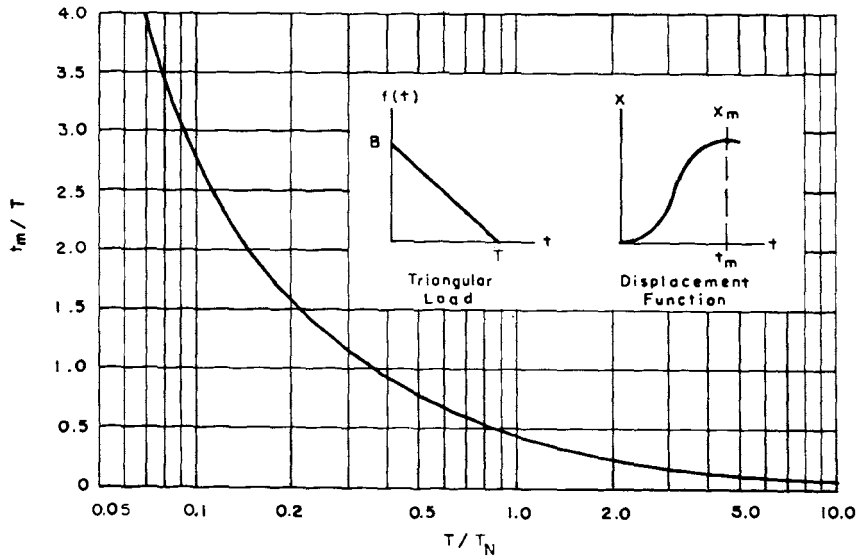
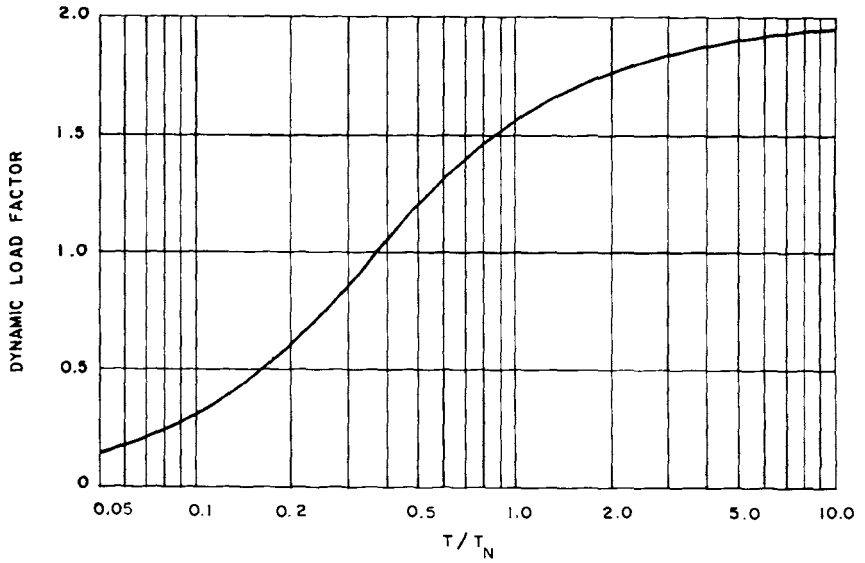

FIG. 6 - Dynamic Load Factor and t_m/T Curves for Linearly Elastic Spring-Mass System, Triangular Load Pulse with Zero Rise Time (Ref. 3).

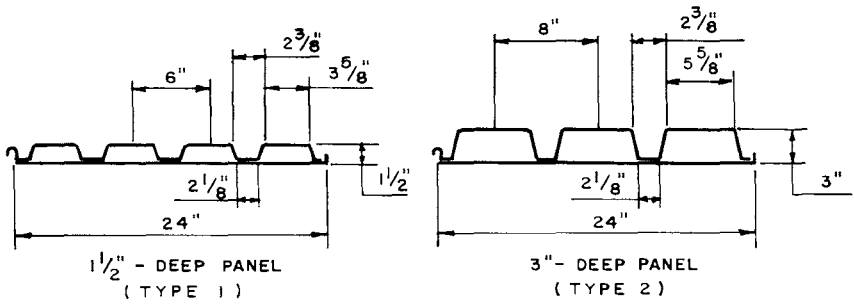
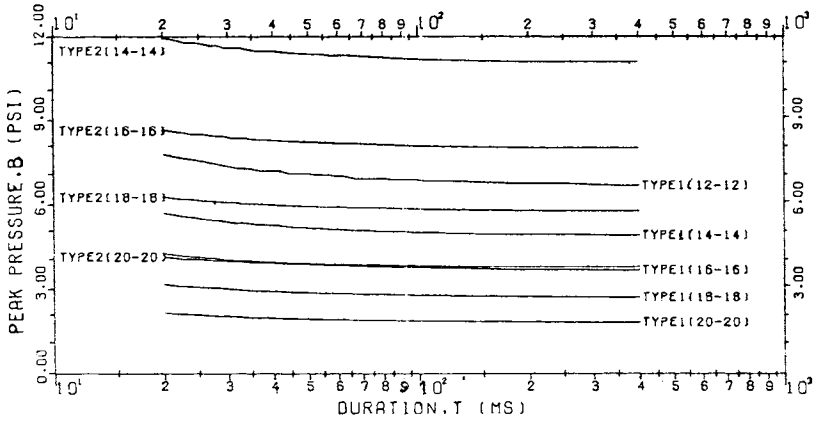
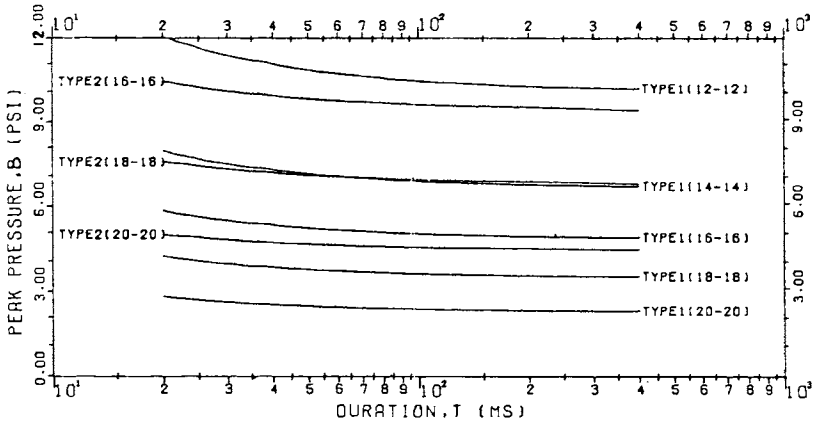

FIG. 7 - Cold-Formed Steel Panel Sections



(a) REUSABLE PANEL, SPAN = 4.0 FT.



(b) NON-REUSABLE PANEL, SPAN = 4.0 FT.

FIG. 8 - Typical Design Chart for Simply-Supported Cold-Formed Steel Panels.

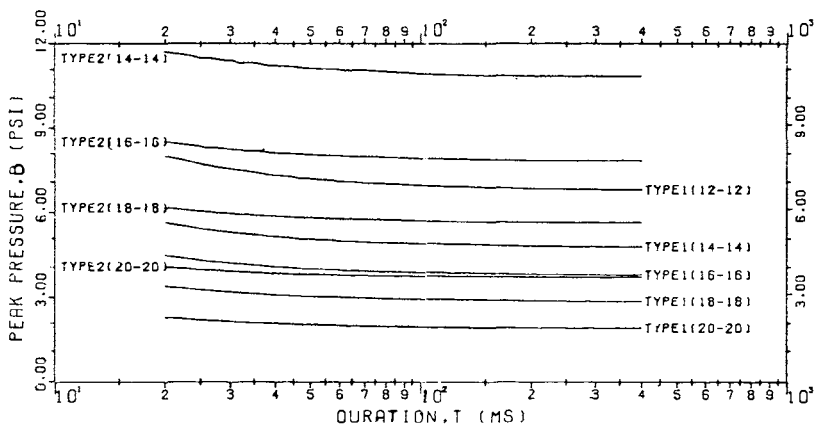

(a) REUSABLE PANEL, SPAN = 5.0 Ft.

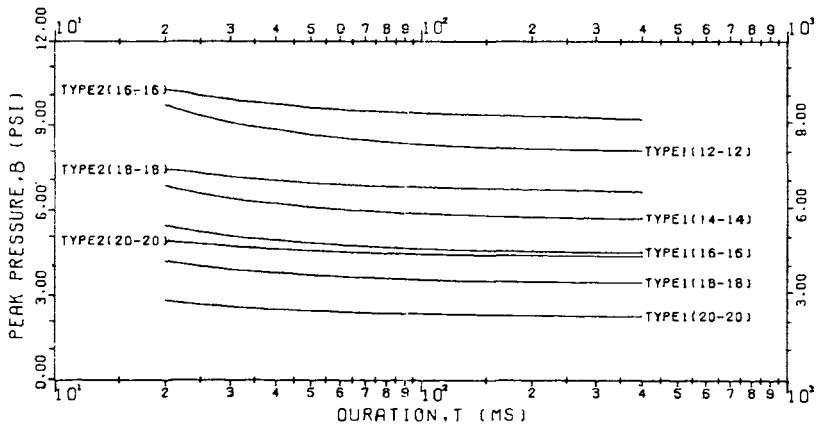

(b) NON-REUSABLE PANEL, SPAN = 5.0 Ft.

FIG. 9 - Typical Design Chart for Equal-Span, Continuous Cold-Formed Steel Panels.



FIG. 10 - Support Structure for Explosive Testing of Cold-Formed Steel Panels (U.S Army Photograph).