



Nov 8th, 12:00 AM

Industrialized Housing with Cold-formed Sheet-steel Elements

J. O. Bats

J. F. G. Janssen

Follow this and additional works at: <https://scholarsmine.mst.edu/isccss>



Part of the [Structural Engineering Commons](#)

Recommended Citation

Bats, J. O. and Janssen, J. F. G., "Industrialized Housing with Cold-formed Sheet-steel Elements" (1988). *International Specialty Conference on Cold-Formed Steel Structures*. 5.
<https://scholarsmine.mst.edu/isccss/9iccfss-session1/9iccfss-session6/5>

This Article - Conference proceedings is brought to you for free and open access by Scholars' Mine. It has been accepted for inclusion in International Specialty Conference on Cold-Formed Steel Structures by an authorized administrator of Scholars' Mine. This work is protected by U. S. Copyright Law. Unauthorized use including reproduction for redistribution requires the permission of the copyright holder. For more information, please contact scholarsmine@mst.edu.

Industrialized Housing with
cold-formed sheet-steel elements.

by

Ir. J.O. Bats *

Ir. J.F.G. Janssen *

Summary

It can be advantageous to employ special mass-produced elements of cold-formed steel sheet in home- (and low rise office) building. This paper contains the results of an up to date study.

I Introduction

In the U.S.A. and Canada, where the "2x4" wood framing system predominates, it is understandable that the steel industry promotes the use of steel in homebuilding by replacing the wooden joists and studs with steel counterparts.

In Europe there are much fewer wood joists and studs to be replaced by steel and the higher density of population in Europe makes it much more usual to live in low and mid-rise flats and apartments. In spite of numerous attempts, successful industrialization of homebuilding has not yet been realized in Europe. We can conclude that development in homebuilding lagged behind in production efficiency compared with other branches of industry. For good comprehension of what follows, we must first make a clear distinction between certain ideas, which are essential to the rest of the argument. This distinction belongs to Professor Habraken and therefore a description as given in [1] will be used.

"For the past 25 years or more, there is a kind of confusion that always seems to plague the discussions about innovation in housing design and production. The discussions about technical innovation, for example, often confuse two distinct kinds of production.

When we discuss the production of houses, perhaps we can say that, when elements or parts that are used for building houses are made before the specific place where they will be positioned is known (i.e. before there is a house design), we have what can be called industrialized production.

If on the other hand we say, that parts are made for building houses after the specific place where they will be used is known (after we have a design), then we call it prefabrication. This is also a familiar and effective way of building. Many things are prefabricated, on and off-site, using industrially produced parts, but only after a design is made to guide their assembly. It is often still the best way to build.

But it is different from industrial production because of the difference in the position of the initiative to produce, relative to the site where the part will be built into a house.

* Assistant professors, Structural Engineering Group Eindhoven University of Technology; the Netherlands.

Habraken made this distinction, which seems to be important for our consideration of the health of a housing industry [2]. Prefabrication is a way of building houses which have been designed. Industrialized production is a way of making parts for use in building operations without dependency on knowledge of the design of the houses in which the elements will be used. It is a distinction in the point of control, and in the point of initiative to act.

The reason the distinction is important is that the debate should be about what general parts to industrially produce, because to be efficient our industries need to know what to produce before house designs are made.

Yet these parts need to be of a nature that they invite interpretation in diverse applications by different parties (flexibility). What general parts make sense?

We will try to give a solution to what are the right general parts suitable for industrial production, especially of low and mid-rise dwelling-blocks in urban residential environments with higher densities, but also useful for single detached houses. The basis for this is a support structure of cold-formed steel-sheet elements, as discussed in chapter II. Some calculations and test results will be given in chapter III.

Study of the literature [3] on industrialization of house-building in the U.S.A. and Western Europe during the last 50 years reveals clearly that

- a. in times of real housing shortage, there were frequent endeavours to increase building capacity by prefabrication of dwellings via all kinds of systems, which were, in most cases, subsidized by the Government, but, when the need had faded away and therefore the subsidy was withdrawn, the system disappeared as well without any impetus to industrialization.
- b. in times of economic recession, the need for low rental dwelling accommodation, has always produced showers of ideas for cheaper ways of house building, but up to now with the same poor results as far as industrialization is concerned.
- c. in Western Europe alone more than a thousand attempts have been made since the second world war. Nevertheless, one can say that during the last 50 years, industrialization of the home building industry has been negligible.

Conclusions of the literature study are that if one wants to achieve anything as to industrialization, then in my opinion, the general parts have to be developed with due observance of the following conditions.

- a. The design must be based on the S.A.R.-method of designing and on modular coordination.
- b. The construction components must be comparatively small.
- c. The construction components must be demountable.
- d. The construction components must be as "simple" as possible.
- e. The network of lines and pipes must be very much independent of the other construction components.
- f. Free choice to position the stairs must be given.

ad a

The support structure of cold-formed steel-sheet has been elaborated further into an architectural design based on the S.A.R. method of designing and modular coordination, as developed by Prof. Habraken. This method explicitly implies working with different levels of control. It is absolutely necessary to use this method of designing.

In order to obtain the required flexibility in the assembling of the different sub-systems together as well as the assembling of the general elements within one sub-system. Otherwise one surely will be lost in an uncontrollable decision problematic.

ad b

When we combine the necessity of industrialization with that of flexibility this gives rise to an important conclusion: namely the necessity of relatively small general parts.

If the fairly general trend to steady increase in dimensions (see fig. 2) of construction components continues, then either flexibility or mass production will be get in danger, since

- introducing variation in the dwellings necessitates, in case of big construction components, a great versatility of those components and this eliminates the possibility of mass production, which causes automatically the tendency to the traditional method of working.
- On the other hand, mass production of big building parts eliminates the variation in housing, which leads to monotony. [4].

In view of the needs for both mass production and flexibility, there is no alternative to relatively small construction components. (general parts).

In this context it is worth noting that the five biggest Japanese producers of dwellings, who achieved an annual production of some hundreds of thousands of prefab dwellings mostly worked on the basis of the modular, volume-enclosing element type (see Fig. 2), consequently with big components.

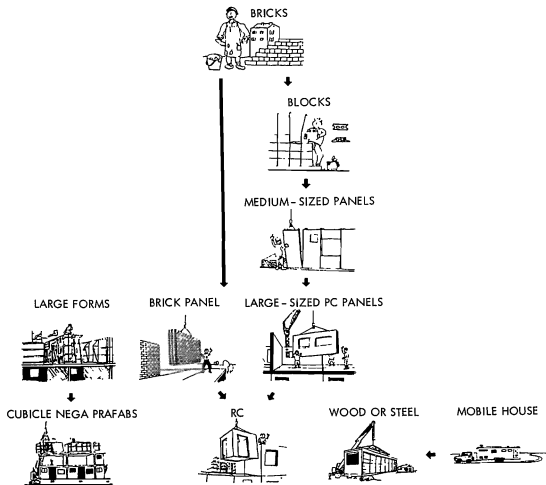

FIG.2 ENLARGEMENT OF COMPONENTS THROUGH PREFABRICATION

Except for the wet-core service modules, there is no question of interchangeability of the elements, thus no question of an open building method. All systems are closed systems. Consequently, they are either too expensive or not flexible enough.

Actually this is confirmed by the director of Daiwa House Industry (28.000 houses per year) because according to him [5].

"There are more than 5000 different types of parts. One unit of housing requires about 600 parts from 150 varieties, which calls for small lot production of an extremely large range of items, even in comparison with such wide scale enterprises as the automobile industry. Recently, home buyers' demands have become highly diversified, so that standardised designs no longer satisfy their requirements. This trend has been gaining even greater momentum."

"We now find ourselves in a position to require NC (numerically controlled) production machinery, robot welding equipment and other equipment which can accommodate production changes."

"Currently, the gradual increase in the market share of prefabricated housing is not so much due to the lower costs brought about by mass production, (mass production is out of the question, there is only small-lot production (J.O.Bats)) as was originally intended, since cost does not differ significantly from conventional homebuilding methods, but rather uniformity of quality, high performance, financial and technical credibility of the manufacturers, accessibility of advice from highly trained and experienced technical personnel and excellent after sales service."

ad c

The possibility to dismount the various (sub)systems in a simple manner is essential if VARIABILITY (the possibility of changing afterwards) is required. Moreover, the (sub)systems should be flexible, which means that it must be possible to apply them in different designs. Furthermore, it is necessary to install all the lines and pipes independently, so that the path of the lines and pipes can be simply adapted in case of repartition of the dwellings. This is often one of the greatest problems when dwellings have to be modified. The same goes for the greatest possible latitude in positioning and removal of the stairs.

ad d

It is not difficult to appreciate that the simpler the construction components the easier it becomes to realize the system of agreements for open building, or a sufficient measure of neutrality of application of assembly components. This is the reason why, for the sake of the open building-method strived after, there has been worked with rigorous separation of functions. The possibility of eventual integration of various functions in the components can be judged much better from their consequences afterwards. In a further conduct of this research the endeavours will absolutely not be focussed on integration in advance.

ad e

When we connect the preceeding explanation, especially as regards item c, with the intention to insert the pipes and lines independently in wall and floor elements, it is evident that this, too, stimulates the singularity of the constructional components to a high degree. The importance of this can be underlined with the following verdict given by Mr. Pestman [6].

"During the past 100 years more and more lines and pipes were introduced into housing, without this giving rise to real integrated solutions. Installations do not have one appropriate spot and, owing to the quite different method of production, they clash with the other materials and techniques."

Choice of a radical solution to this problem seems to be a first requisite. This will be done consistently in the discussion about the steel support system later on in this article.

ad f

It will be evident that liberty as in positioning of the stairs is essential to flexibility as well as variability.

The above explanation will have made clear that the problems of house building necessitate innovation which by itself practically leads to the introduction of the "open building system".

The remaining item is the motivation of the choice of the material.

This motivation is based mainly on the two points given below.

1. The disadvantage of the present-day application of concrete.
2. The developments abroad, particularly in Japan.

ad l

The disadvantage of the application of concrete on the scale that has developed after the second world war is reflected in Fig. 3. During the sixties and thereafter the method of construction by casting has proved to be price-setting for the low-rental house building. This is a very important reason for the gigantic increase in the application of concrete.

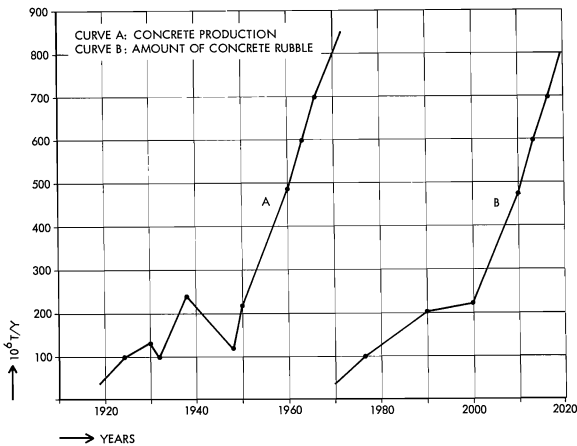

FIG. 3 ESTIMATE OF CONCRETE PRODUCTION AND AMOUNT OF CONCRETE RUBBLE TO BE EXPECTED FROM DEMOLITION IN EEC

In a symposium report on recycling [7] Prof. ir. P.C. Kreijger words his thoughts on this subject as follows:

"It is more and more being realized that in densely populated areas there is, on the one hand, no room left for dumping places, while on the other, as these areas in particular run short of aggregate for concrete, distances of transport and increasing intensity of traffic on roads and waterways make the acquisition of filler materials more and more expensive.

Moreover, the nuisance caused by noise and dust becomes more and more unacceptable."

A equally important disadvantage of the use of the concrete construction method is the total lack of flexibility of the dwellings so made. For any material whatsoever, it will depend particularly on the possibility of building with it in a demountable manner, whether any material will find large-scale application.

In this connection, steel is the material that seems to have the advantage. Furthermore, steel offers the following possibilities

1. to work with great dimensional accuracy,
2. to use manoeuvrable prismatic elements,
3. to avoid creep or shrinkage,
4. to design light foundations owing to the very low weight of the construction.

Dwelling-units on the basis of a support made of steel are very light and stiff, and for this reason too, suitable for application in, and export to areas which are exposed to earthquakes.

ad 2

An important indication that steel may have advantages is the development of industrial house-building in Japan.

The trends in industrial house building in Japan is given in fig. 4, divided in accordance with the most important building materials.

This shows a fairly moderate rise for systems based on steel compared to a sharp fall of systems based on concrete.

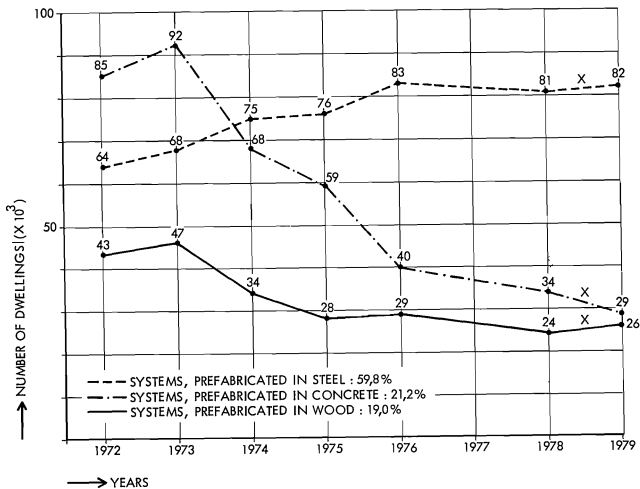
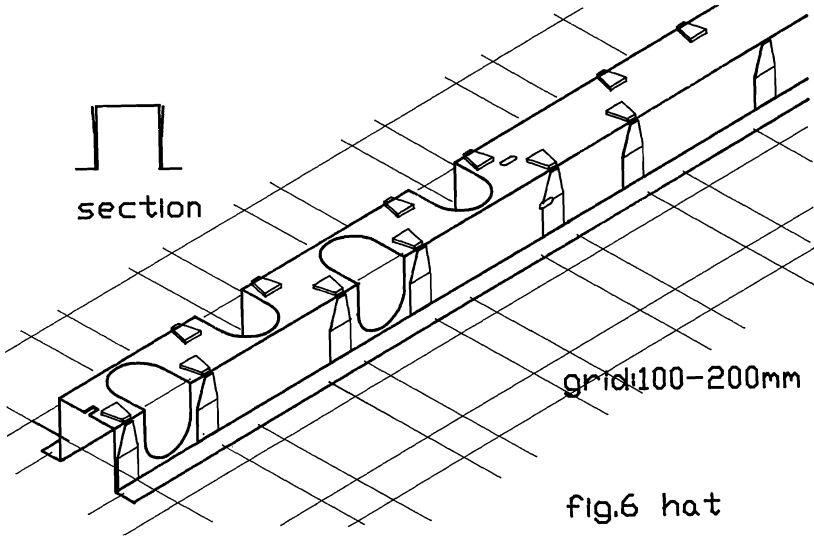
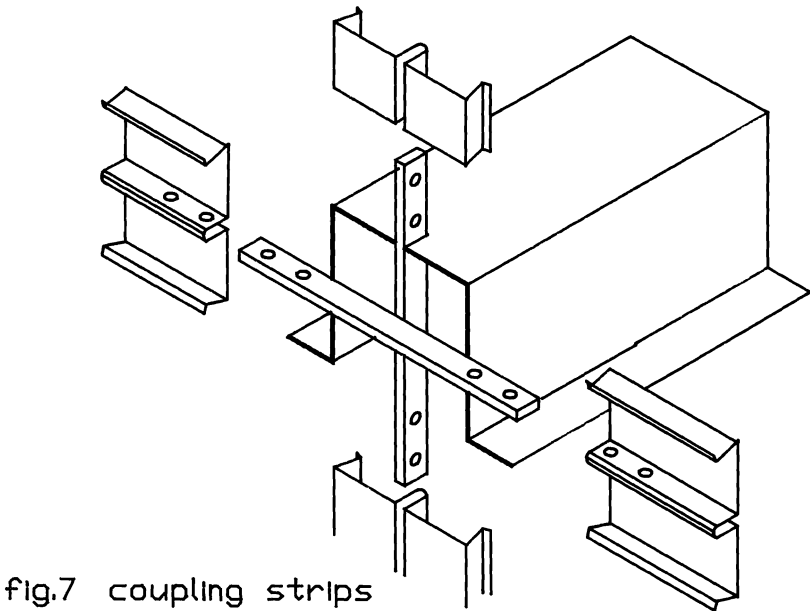

FIG.4 PRODUCTION OF INDUSTRIALIZED HOUSES IN JAPAN

Steel support elements of this kind, together with a so-called "hat-profile" (fig. 6) form the "support structure" of the support.



For securing the horizontal and vertical coherence, coupling strips are needed (fig. 7)



The "house of cards" still requires stability provisions in the form of steel-sheet shear walls in the transversal direction. In all, this results in the bearing structure shown below in fig. 8.

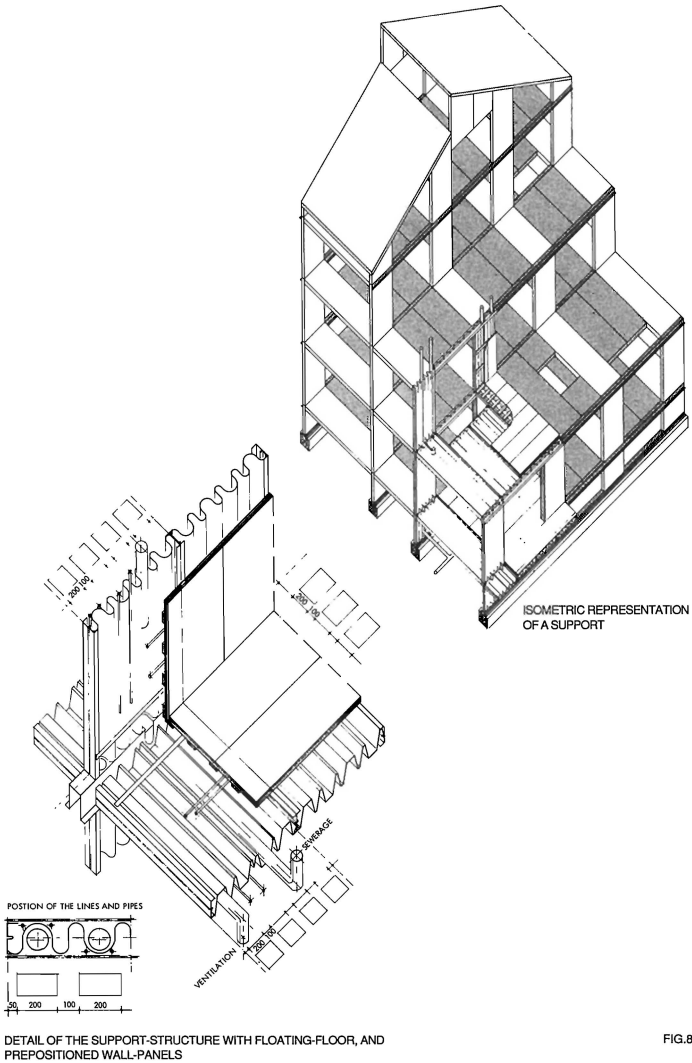

FIG.8

All the four elements of the support structure will now be briefly dealt with in succession:

- 1: the support element
- 2: the hat
- 3: the couplings
- 4: the shear walls.

1. The support element (fig. 5)

The architectonic support design shows that an element width of 1.20 m presents no problems for the possibilities of use of the support. This width was chosen for several reasons

- The developed length of the corrugated plate is in this case approximately 2.40 m, so that it can be produced from two coils which have a current width of approximately 1.25 m.
- The number of major lines and pipes which each element can contain is 4 (an even number) so that each side of the element can contain 2 of them (one for the sewerage and one for ventilation, for instance).
- The axial loadbearing capacity is ample.

Concerning this last item, elements with a width of 0,6 m possess a bearing capacity amply sufficient to build 3 to 4 floors high.

It is particularly the necessary possibility to accommodate big lines and pipes that is important, and therefore the use of elements with a width of 1.20 m is preferable. In a double aisled structure, built up of elements with a width of 1.20 m. each span of about 6 m can contain 24 - 32 big vertical lines and pipes for sewerage and ventilation, each with a diameter of approximately 110 mm, which seems to be sufficient for about 3 - 4 floors.

The support elements consists of 2 cold-formed, u-shaped profiles and a corrugated steel sheet, to which u-shaped profiles are secured in axial direction by spot-welding.

These u-shaped profiles are provided with at least one dimple which increases the axial load-bearing capacity and, furthermore, makes it possible to couple the elements in a simple manner. The thickness of the corrugated sheet is approximately 0.75 mm, that of the u-shaped profiles is about 1.5 mm.

The U-shaped profiles have several functions.

- they stiffen the edges of the vertical parts of the support so as to absorb the support reactions of the "hat", which is used as a lintel (see below),
- they allow for a simple vertical or horizontal connection of the support elements one to another which can be made and removed in a simple and quick way.
- front and rear wall styles can be secured on them,
- they support the stiffening near staircase holes,
- they serve as the connection member of the shear wall sheets.

A 1.20 m wide element weighs 190 N/m (160 N/m^2).

The elements can be made in a range of linear measures of

$l = n.300 - 154$ where in $n = 2$ up to 17 (see fig. 9).

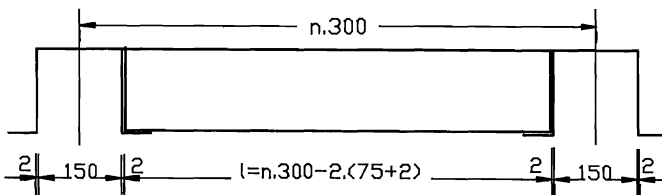

fig.9

The shortest length is $l = 446$ mm ($n = 2$) and in view of the given element dimension, the longest possible element is $l = 4946$ mm ($n = 17$).

With this range of elements in two widths, a wide scale of different support structures can be built. It is thus possible to meet the wishes of occupants to a large extent. (My colleague will demonstrate this in his part of our presentation by means of several examples. The real number of possibilities will be much higher).

The vertical support elements will have a length of $l = 2840$ mm ($n = 10$).

2. The "Hat" (fig. 6)

For the connection of the horizontal and vertical parts of the support a so-called "hat-profile" made of cold-formed sheet steel with a thickness of 2 mm is used. This hat can be undivided in cross-section, but can also be compiled of two Z-shaped profiles.

This "hat" allows the horizontal parts to be laid on. Furthermore, it serves.

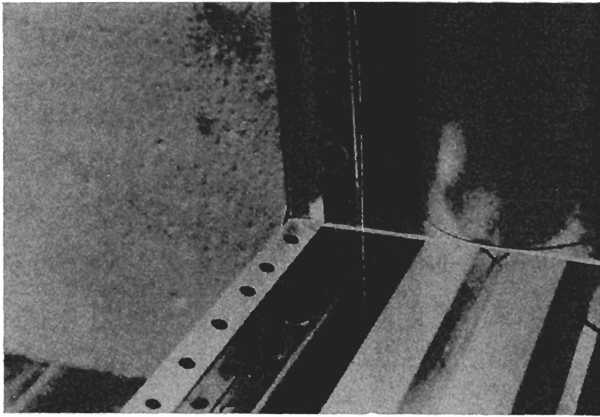

DETAIL OF THE COUPLING

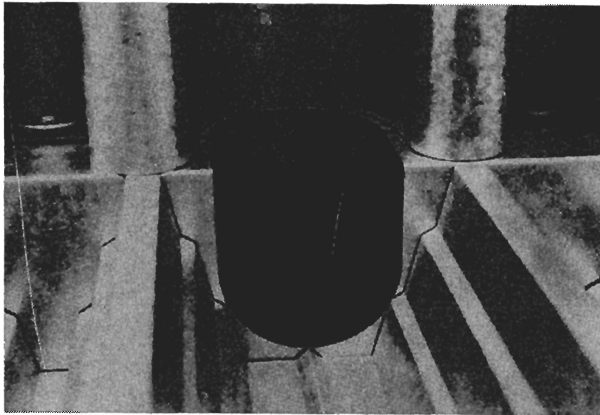

HOLE FOR BIG PIPE

Fig. 10

- as a lintel between vertical parts of the support,
- to position elements correctly by means of the small spotwelded or stamped out parts (see fig. 10). These small parts are useful for taking up the horizontal and vertical shear forces. Applying them, within definite size tolerances, in the factory makes assembly of the support very easy.

3. Horizontal and vertical coupling-strips (fig. 7)

On both sides of the vertical support elements couplings are made by means of horizontal and vertical coupling-strips. This is necessary to take up the positive normal forces (see fig. 7 and 10). Strips with dimensions of 10x25 mm can be located within the dimple of the u-profile on the sides of the support element. Horizontal and vertical coupling-strips may cross each other in the respective dimples on both sides of the contact surface between 2 elements.

4. Transverse stabilization

In order to achieve horizontal stability, steel sheet shear walls are positioned at a suitable place, parallel to the front and the back faces of the building; for instance on the borders of the β -zone (see fig. 11) Furthermore, they are fastened there between the support elements adjoining each other in such a way that the same kind of connection can be used as for the coupling strips.

It is also possible to use part of the facade and rear wall to obtain transverse stability.

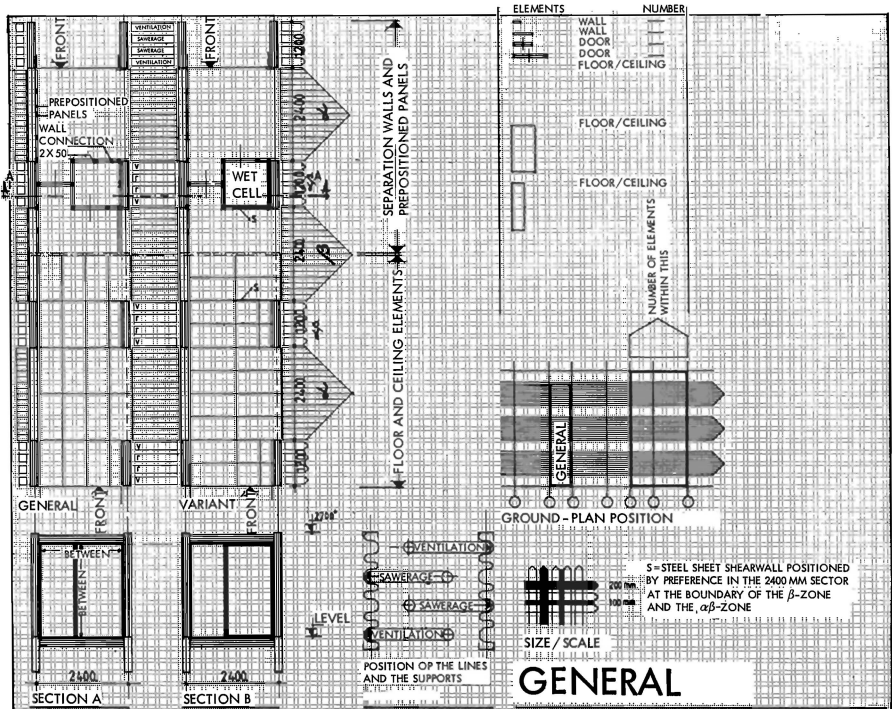

FIG.11 SOME DETAILS OF THE SUPPORT-STRUCTURE

Further remarks

a. The support structure developed shows a practically absolute latitude as to the position of the stairs in the beta and the two alpha zones (see fig. 8 and 11.)

Furthermore, it offers good possibilities for voids.

b. There are series of elements to be chosen for the various (sub)systems. Next to the floating-floor system, the prepositioned wall-panel system and the ceiling system, the most important one is the separating wall system. Fig. 11 gives a schematic representation on the basis of agreements relating to the S.A.R.-method of designing and the modular coordination.

Fig. 12 gives a detail of a proposal.

These series of elements will have to be developed further, just as a suitable facade and roof system.

This will be done in cooperation with different concerned industries in a 1:1 experimental module built-up on the campus of the university.

All these systems will not be discussed in this paper.

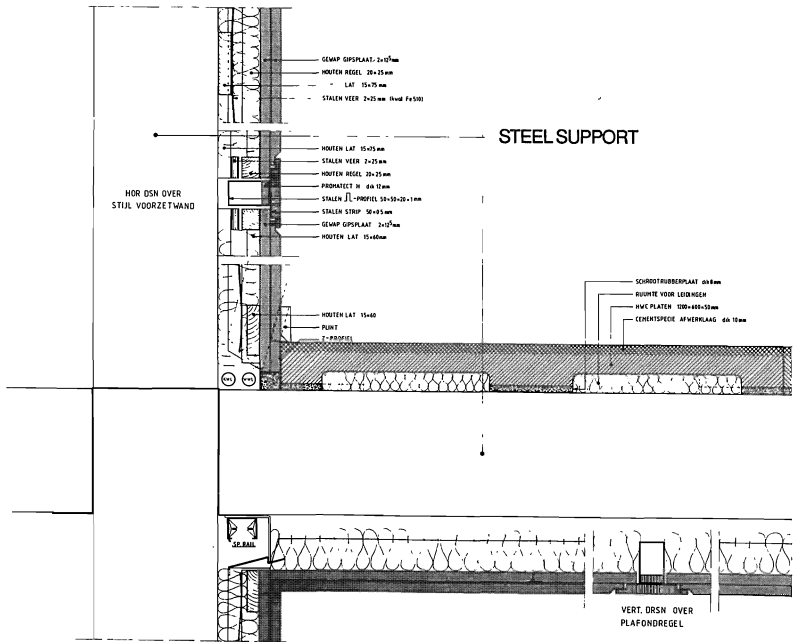

FIG. 12 DETAIL OF THE SUPPORT-STRUCTURE WITH FLOATING-FLOOR, PREPOSITIONED WALL-PANELS AND CEILING

III Some test results

To become acquainted with the behaviour of the support structure under loading, some calculations have been made and a series of orientating tests set up. Meanwhile the tests are partly carried out.

The behaviour of the support structure depends in the first place on the bearing capacity of the elements themselves. The design moment (M_d) and the moment of inertia (I_{eff} at $2/3 M_d$), which are important for the horizontal elements, are calculated in accordance with the ECCS recommendations [8]. This results in the following values for the two elements width

0.60 m and 1.20 m and a material quality F_e 410 with $\sigma_e = 280 \text{ N/mm}^2$:

$$M_d [0.6] = 14.6 \text{ kNm}; \quad M_d [1.2] = 23.7 \text{ kNm}$$

$$I_{eff} [0.6] = 393.10^4 \text{ mm}^4; \quad I_{eff} [1.2] = 638.10^4 \text{ mm}^4$$

These values meet the requirements of the Dutch Regulations for building construction up to a maximum span of 5.10 m as far as homebuilding goes. To meet the more stringent requirements for low- and mid-rise office buildings with at the same time a preferable span of 5.40 m, it is necessary to use steel sheet, 1 mm thick instead of 0.75 mm.

For this the calculated values are:

$$M_d [0.6] = 17.7 \text{ kNm}; \quad M_d [1.2] = 29.9 \text{ kNm}$$

$$I_{eff} [0.6] = 475.10^4 \text{ mm}^4; \quad I_{eff} [1.2] = 800.10^4 \text{ mm}^4$$

In order to determine the axial loadbearing capacity, tests are made in two steps on test pieces with dimensions of 600 x 600 mm. The thickness of the material is 0.75 mm and the quality also F_e 410.

- 1e Three test pieces of corrugated steel sheet, without u-shaped profiles in axial direction.

The pressure tests are carried out in a servo-controlled testing machine till collapse (Fig. 13).

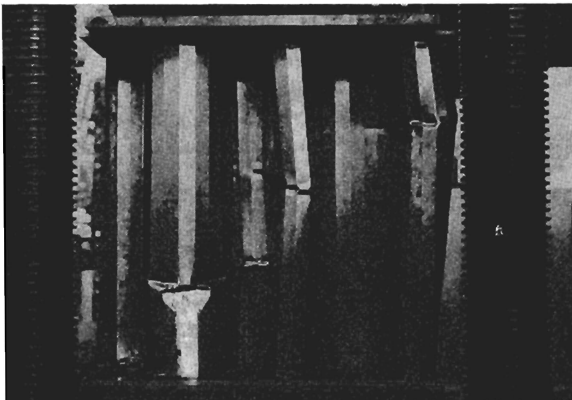

Fig. 13a

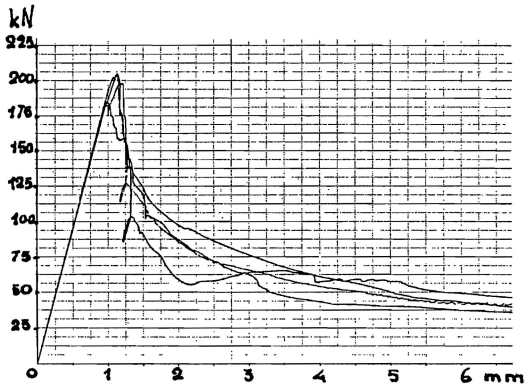
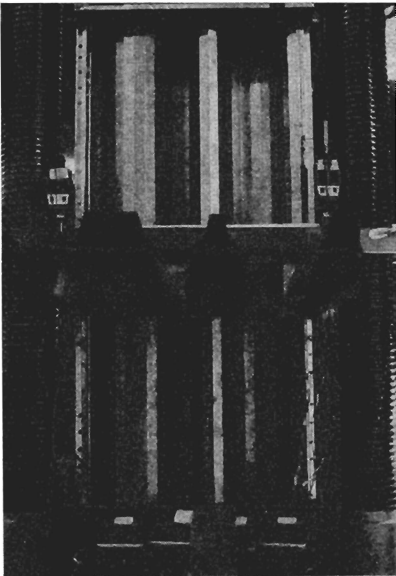
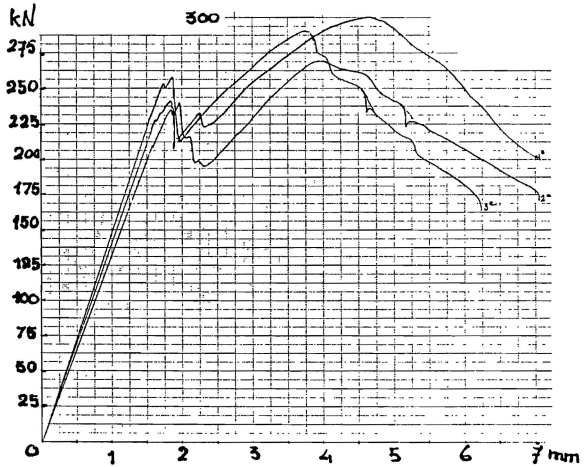

fig. 13 b.



a



b

Fig. 14

- 2e) The three testing pieces are intended for simultaneous testing of the main connection under vertical axial load (Fig. 14). The separate elements of 600x600x0.75 mm are in this case provided with u-shaped profiles in the axial direction. These tests are carried out in the same testing machine as mentioned before. The graph in Fig. 14 reflects a much better behaviour of the test pieces with the two spotwelded u-shaped profiles. The maximum load is on a higher level and the collapse behaviour is more moderate. More tests, for instance, on elements of a width of 1.20 m and a length of 2.84 m will be made.

The test set-up of Fig. 15 has been build to determine the shear-resistance in plane of the elements.

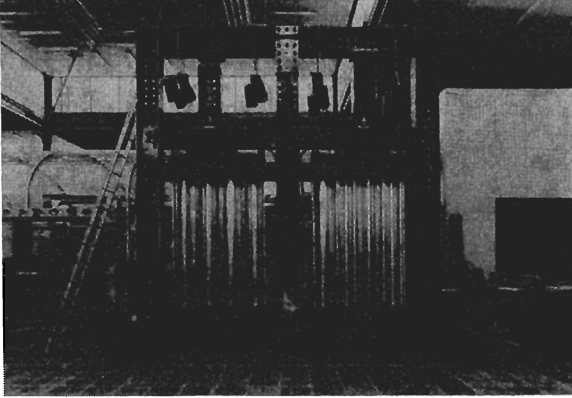

Fig. 15

A model of a part of the 1:1 experimental module as at will be built on the campus of the University is shown in Fig. 16.

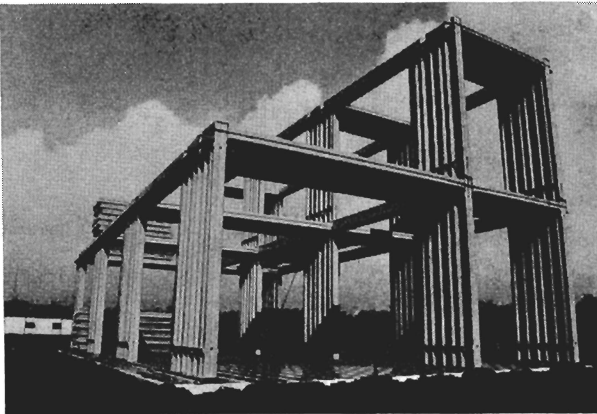

Fig. 16

IV Conclusions

- The building industry is technically behind in development and therefore expensive and does not meet the requirements of the consumer.
- In order to change to a more favourable direction it is necessary to find out what "general parts" can be mass-produced by the building industry.
- The only alternative for lower-cost building is to industrialize the production of the general parts.
- In order to retain high market value and widespread acceptance in society, the significance of adaptability in housing by using these general elements has to be recognized and understood by both the general consumer and the housing industry. When the components are real "general components" then individualized and richly adaptable houses will be realized.
- The proposed support structure, including the subsystems, is an attempt to stimulate the development of the general parts. In this case cold-formed steel-sheet is used.

Literature References

- [1] Article by Kendall and Sewada, "Changing patterns in Japanese housing", *Open House International*. Vol. 12, No. 2, 1987.
- [2] Habraken, N. John, *Transformations of the Site*, Awater Press, Cambridge, Mass. 1983.
- [3] Bats, ir. J.O. en Thijsen, ir. A.P. "Stalen Drager I", april 1983.
- [4] Y. Utida, *Expectations and Images Toward the Open System*, undated English language reprint from a book by Utida, *Open Systems in Building Production*, published in Japanese (1977).
- [5] Togo, T. "Industrialized housing in Japan: steel-frame prefabricated houses", 20 I.I.S.I. Conference, Rio de Janeiro, 5-8 October 1986.
- [6] Pestman: *Het CEPEZED Bouwstelsysteem* PT/Bouwtechniek 37 (1982), nr. 12.
- [7] Kreijger, P.C., *Adhesion problems in the recycling of concrete*. NATO-conference, series IV-4;
- [8] ECCS/CECM/EKS, "European Recommendations for the design of profiled sheeting", No. 40, *European Convention for Constructional Steelwork*, published by Constrado, Croydon, England, 1983.

