



Missouri University of Science and Technology  
**Scholars' Mine**

---

Center for Cold-Formed Steel Structures Library

Wei-Wen Yu Center for Cold-Formed Steel Structures

---

01 Jan 2001

## Metal drywall framing and accessories

Dale Industries

Follow this and additional works at: <https://scholarsmine.mst.edu/ccfss-library>

 Part of the [Structural Engineering Commons](#)

---

### Recommended Citation

Dale Industries, "Metal drywall framing and accessories" (2001). *Center for Cold-Formed Steel Structures Library*. 224.

<https://scholarsmine.mst.edu/ccfss-library/224>

This Technical Report is brought to you for free and open access by Scholars' Mine. It has been accepted for inclusion in Center for Cold-Formed Steel Structures Library by an authorized administrator of Scholars' Mine. This work is protected by U. S. Copyright Law. Unauthorized use including reproduction for redistribution requires the permission of the copyright holder. For more information, please contact [scholarsmine@mst.edu](mailto:scholarsmine@mst.edu).

# Metal Drywall Framing and Accessories



**THE LARGEST  
SOURCE FOR PRIME  
STEEL PRODUCTS**

## Table of Contents:

Track .....Page 2  
 Studs .....Page 3  
 Accessories .....Page 4  
 Area Separation Wall (H-Stud) .....Page 5  
 Shaft Wall Components .....Page 6 & 7  
 Beads .....Page 8

## About The Company

Dale Industries was founded in May, 1952. Today, with plants in Dearborn, MI - Baltimore, MD - Ft. Lauderdale, FL - Birmingham, AL - Tampa, FL and Houston, TX. Dale is a major supplier to the drywall and light gage steel industry.

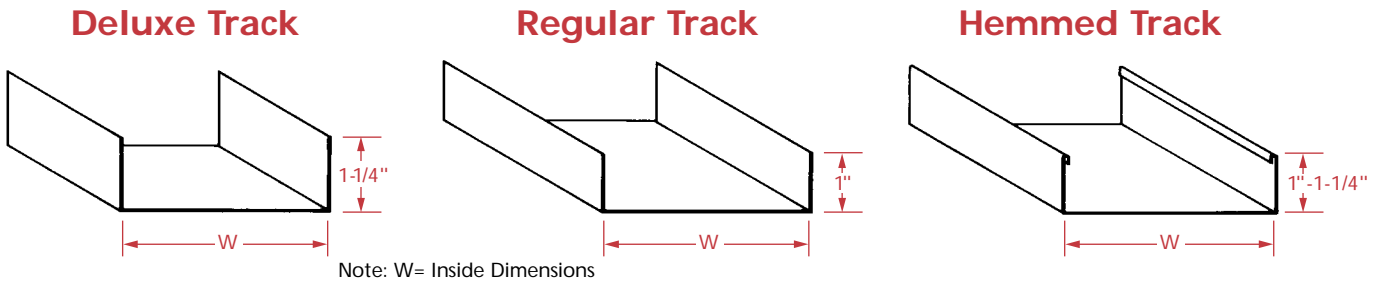

Track is used to anchor the partition at floor and ceiling. Sections are roll formed steel in a channel configuration with hemmed or unhemmed leg in 1" or 1-1/4" depths. Sections are manufactured to receive the corresponding size of the studs with an overbend for a friction fit. DALE/INCOR's standard 25, 22, and 20 gage track meets ASTM C-645, A568-00a, and A653. The properties and weights shown are calculated on minimum thicknesses in accordance to A.I.S.I. Specifications.

## Physical and Structural Properties

### 20 Ga. RT-Regular Track, 1" Leg, (Web) T 100-30

Web in, (1/100in.)	WT. (lb/ft.)	A (in <sup>2</sup> )	I <sub>x</sub> (in <sup>4</sup> )	S <sub>x</sub> (in <sup>3</sup> )	M <sub>a</sub> (in-k)
1-5/8", (162)	0.38	0.113	0.058	0.065	0.95
2-1/2", (250)	0.48	0.140	0.146	0.111	1.69
3-5/8", (362)	0.60	0.175	0.341	0.181	2.88
4", (400)	0.64	0.187	0.429	0.207	3.33
6", (600)	0.85	0.250	1.142	0.372	5.34

### 20 Ga. DT-Deluxe Track, 1-1/4" Leg, (Web) T 125-30

Web in, (1/100in.)	WT. (lb/ft.)	A (in <sup>2</sup> )	I <sub>x</sub> (in <sup>4</sup> )	S <sub>x</sub> (in <sup>3</sup> )	M <sub>a</sub> (in-k)
1-5/8", (162)	0.44	0.129	0.070	0.079	1.00
2-1/2", (250)	0.53	0.156	0.173	0.131	1.77
3-1/2", (350)	0.64	0.187	0.365	0.200	2.86
3-5/8", (362)	0.65	0.191	0.395	0.210	3.01
4", (400)	0.69	0.203	0.495	0.239	3.49
6", (600)	0.90	0.265	1.288	0.419	5.37

### 25 Ga. RT-Regular Track, 1" Leg, (Web) T 100-18

Web in, (1/100in.)	WT. (lb/ft.)	A (in <sup>2</sup> )	I <sub>x</sub> (in <sup>4</sup> )	S <sub>x</sub> (in <sup>3</sup> )	M <sub>a</sub> (in-k)
1-5/8", (162)	0.23	0.068	0.035	0.040	0.48
2-1/2", (250)	0.29	0.085	0.088	0.067	0.88
3-1/2", (350)	0.35	0.103	0.189	0.104	1.22
3-5/8", (362)	0.36	0.106	0.205	0.110	1.26
4", (400)	0.38	0.113	0.259	0.125	1.38
6", (600)	0.51	0.151	0.689	0.225	

### 22 Ga. DT-Deluxe Track, 1-1/4" Leg, (Web) T 125-27

Web in, (1/100in.)	WT. (lb/ft.)	A (in <sup>2</sup> )	I <sub>x</sub> (in <sup>4</sup> )	S <sub>x</sub> (in <sup>3</sup> )	M <sub>a</sub> (in-k)
1-5/8", (162)	0.40	0.117	0.063	0.072	0.87
2-1/2", (250)	0.48	0.141	0.157	0.119	1.56
3-1/2", (350)	0.58	0.170	0.331	0.182	2.53
3-5/8", (362)	0.59	0.173	0.358	0.191	2.66
4", (400)	0.63	0.184	0.449	0.217	3.08
6", (600)	0.82	0.241	1.168	0.381	4.44

### 25 Ga. HT-Hemmed Track, 1-1/4" Leg, (Web) T 125-18

Web in, (1/100in.)	WT. (lb/ft.)	A (in <sup>2</sup> )	I <sub>x</sub> (in <sup>4</sup> )	S <sub>x</sub> (in <sup>3</sup> )	M <sub>a</sub> (in-k)
1-5/8", (162)	0.28	0.082	0.045	0.051	0.58
2-1/2", (250)	0.33	0.098	0.111	0.085	1.02
3-5/8", (362)	0.41	0.120	0.253	0.135	1.46
4", (400)	0.43	0.127	0.316	0.153	1.61
6", (600)	0.56	0.164	0.817	0.267	

### 25 Ga. DT-Deluxe Track, 1-1/4" Leg, (Web) T 125-18

Web in, (1/100in.)	WT. (lb/ft.)	A (in <sup>2</sup> )	I <sub>x</sub> (in <sup>4</sup> )	S <sub>x</sub> (in <sup>3</sup> )	M <sub>a</sub> (in-k)
1-5/8", (162)	0.26	0.078	0.042	0.048	0.51
2-1/2", (250)	0.32	0.094	0.105	0.080	0.90
3-1/2", (350)	0.38	0.113	0.221	0.122	1.25
3-5/8", (362)	0.39	0.115	0.240	0.127	1.30
4", (400)	0.42	0.122	0.300	0.145	1.43
6", (600)	0.54	0.160	0.776	0.254	

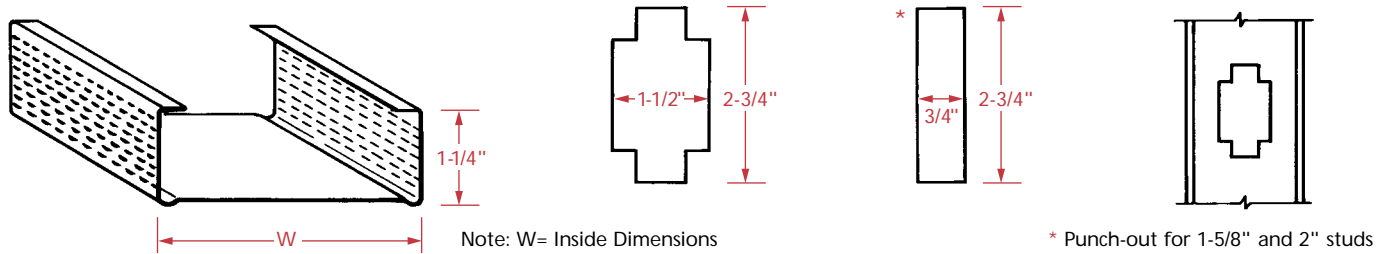

Drywall studs are roll-formed channel type non-load bearing steel members used extensively for interior partitions. Outer flanges are knurled to prevent screw ride and to expedite attachment O.C. Thereafter to accommodate the installation of any required bridging, conduit, or wiring. Dale/Incor's standard 25, 22, and 20 gage studs meet ASTM C-645 and A-653. The properties and weights shown below are calculated on minimum thicknesses in accordance with A.I.S.I. Specifications.

## Section Properties "DWS"

Example: (Web)-S-125-(Ga.)

Web in. (1/100in.)	GA. in., (Mils)	WT. lb/ft.	A (in <sup>2</sup> )	I <sub>x</sub> (in <sup>4</sup> )	S <sub>x</sub> (in <sup>3</sup> )	M <sub>a</sub> (in-K)
1-5/8", (162)	25, (18)	0.27	0.080	0.038	0.046	0.66
	22, (27)	0.41	0.120	0.056	0.068	1.01
	20, (30)	0.45	0.131	0.061	0.075	1.16
2-1/2", (250)	25, (18)	0.33	0.097	0.099	0.079	1.17
	22, (27)	0.49	0.144	0.147	0.118	1.81
	20, (30)	0.54	0.159	0.161	0.129	2.06
3-1/2", (350)	25, (18)	0.39	0.115	0.215	0.123	1.72
	22, (27)	0.59	0.173	0.320	0.183	2.90
	20, (30)	0.65	0.190	0.351	0.201	3.29

Web in. (1/100in.)	GA. in., (Mils)	WT. lb/ft.	A (in <sup>2</sup> )	I <sub>x</sub> (in <sup>4</sup> )	S <sub>x</sub> (in <sup>3</sup> )	M <sub>a</sub> (in-K)
3-5/8", (362)	25, (18)	0.40	0.118	0.234	0.129	1.78
	22, (27)	0.60	0.176	0.347	0.192	3.05
	20, (30)	0.66	0.194	0.381	0.210	3.46
4", (400)	25, (18)	0.42	0.125	0.294	0.147	1.96
	22, (27)	0.64	0.187	0.438	0.219	3.52
	20, (30)	0.70	0.206	0.481	0.240	3.99
6", (600)	25, (18)	0.55	0.162	0.778	0.259	
	22, (27)	0.83	0.243	1.160	0.387	5.42
	20, (30)	0.91	0.268	1.275	0.425	6.54

## Limiting Heights Table (Based on 5 PSF Interior Wind Load.)

Web in. (1/100in.)	GA. In., (Mils)	No Sheathing						1/2" Layer Gypsum Board Each Side					
		16" O.C.			24" O.C.			16" O.C			24" O.C.		
		L/120	L/240	L/360	L/120	L/240	L/360	L/120	L/240	L/360	L/120	L/240	L/360
1-5/8", (162)	25, (18)	8' 8"	6' 11"	6' 0"	7' 7"	6' 0"	5' 3"	10' 7"	8' 4"		9' 9"	7' 11"	
	22, (27)	10' 3"	8' 1"	7' 1"	8' 11"	7' 1"	6' 2"						
	20, (30)*	10' 6"	8' 4"	7' 3"	9' 2"	7' 3"	6' 4"	11' 9"	9' 4"		10' 9"	8' 7"	
2-1/2", (250)	25, (18)	12' 0"	9' 6"	8' 4"	10' 2"	8' 4"	7' 3"	13' 3"	11' 3"	9' 10"	11' 10"	10' 7"	9' 3"
	22, (27)	14' 1"	11' 2"	9' 9"	12' 4"	9' 9"	8' 6"						
	20, (30)*	14' 7"	11' 7"	10' 1"	12' 9"	10' 1"	8' 10"	15' 9"	12' 6"	10' 10"	14' 2"	11' 4"	9' 10"
3-5/8", (362)	25, (18)	15' 4"	12' 9"	11' 2"	12' 7"	11' 2"	9' 9"	19' 5"	16' 5"	12' 10"	11' 2"	14' 10"	11' 7"
	22, (27)	18' 9"	14' 11"	13' 0"	16' 5"	13' 0"	11' 4"						
	20, (30)*	19' 5"	15' 5"	13' 5"	17' 0"	13' 5"	11' 9"	19' 7"	16' 0"	13' 10"	11' 6"	14' 6"	12' 6"
4", (400)	25, (18)	20' 1"	15' 11"	13' 11"	17' 6"	13' 11"	12' 2"	20' 8"	16' 5"	14' 3"	18' 6"	14' 9"	12' 9"
	22, (27)	20' 3"	16' 1"	14' 0"	17' 8"	14' 0"	12' 3"						
	20, (30)*	21' 0"	16' 8"	14' 7"	18' 4"	14' 7"	12' 8"	21' 10"	17' 8"	15' 4"	19' 7"	15' 11"	13' 10"
6", (600)	25, (18)	21' 8"	17' 3"	15' 0"	18' 11"	15' 0"	13' 2"	23' 1"	18' 4"	15' 11"	20' 9"	16' 5"	14' 3"
	22, (27)							19' 9"	19' 9"	17' 11"	16' 9"	16' 9"	16' 9"
	20, (30)*	26' 10"	22' 4"	19' 6"	21' 11"	19' 6"	17' 1"						

\*: composite values based on interpolation of test data.

f: flexural stress controls allowable wall height

### Foot Notes:

- D- Distance between the centroid of the section and the web center.
- I<sub>x</sub>- Moment of inertia for deflection about the x-axis.
- S<sub>x</sub>- Section modulus for load about the x-axis.
- R<sub>x</sub>- Radius of gyration about the x-axis.
- I<sub>y</sub>- Moment of Inertia about the y-axis.
- S<sub>y</sub>- Section modulus about the y-axis.
- R<sub>y</sub>- Radius of gyration about the Y-axis.
- M<sub>A</sub>- Allowable resisting moment. Listed values incorporate the effects of cold forming as allowed per section A7.2 of the 1996 A.I.S.I. "Specification for Design of Cold Formed Steel Structural Members".

### Notes for the Limiting Heights Table:

To attain values listed, attachment of drywall stud to runner track with (1) type S drywall screwed to each side, top and bottom, is required. If facing

material is not applied to both sides of the framing then horizontal bridging is required. The spacing of this bridging shall not exceed 5'0" O.C.

### Note for the Limiting Height W/Gypsum Board Table:

Drywall installation shall be in accordance with A.S.T.M. C840-99a "Application and Finishing of Gypsum Board".

The following are thicknesses for Dale/Incor drywall products:

Gauge	In.	Mils
25 ga.	0.018	18
22 ga.	0.027	27
20 ga.	0.030	30

## Drywall Furring Channel (DWC)

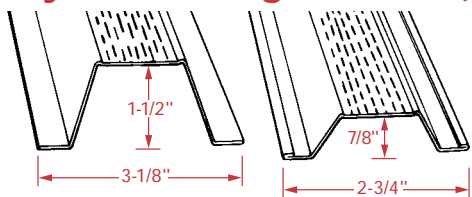

### Uses:

- Convenient accessory components for use in furring out ceilings and masonry walls. Knurled face prevents screw "ride" when attaching gypsum wallboard.
- 1-1/2" DWC is economical with respect to furring walls with electrical boxes, (no need to set into concrete).

Product	GA.	WT/FT
7/8"DWC	25	.275
7/8"DWC	20	.477
1-1/2"DWC	25	.345
1-1/2"DWC	20	.599

### Product Data:

- Available in 7/8" and 1-1/2" sizes.
- Gauge: Standard 25 Ga., also in 22, 20, 18, and 16 gauges.
- Lengths: Standard stock 12'0", (other lengths available upon request)

Consult Dale/Incor's Light Gage Steel Framing Catalog for Structural Properties and Span Tables

## Resilient Furring Channel (RFC)

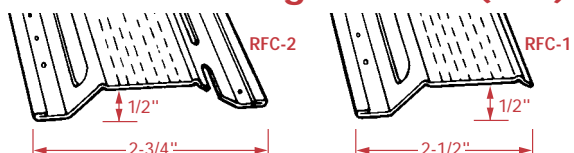

### Uses:

- Economical method of controlling sound transmission through wood framed or steel-framed walls and ceilings.

### Product Data:

- RFC1: Single Leg
- RFC2: Double Leg
- Gauge: Standard 25 gage conforming to ASTM A-653 and C-645.
- Lengths: 12'0" stock length.
- RFC1: Screw attachment, one side only.

Product#	WT/FT
RFC-1	.200
RFC-2	.240

## Z-Furring Channel (ZFC)

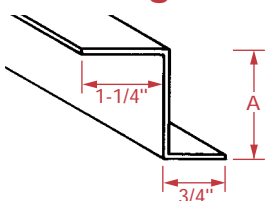

### Uses:

- Designed to accommodate the installation of rigid insulation board while providing an attachment for drywall or other facing materials to the interior side of masonry or monolithic concrete walls.

### Product Data:

- Available in Hot-Dipped galvanized steel conforming to ASTM A-653 and C-645.
- Gauges: Standard 25 gauge, (available in 22, 20, 18, and 16 gauge upon request).
- Lengths: Standard 10'0" and 8'6" lengths, (other lengths upon request).

Product Number	(A) IN. Size	25 Ga. WT/FT
Z-075	.75	.180
Z-100	1.00	.195
Z-150	1.50	.225
Z-200	2.00	.260
Z-250	2.50	.290
Z-300	3.00	.325

## Cold-Rolled Channel (CRC)

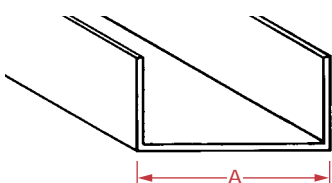

For physical structural properties and span tables consult Dale/Incor's Light Gage Steel Framing catalog 05400.

### Uses:

- Bridging, (Lateral Support) in walls carrying axial and/or wind loads.
- Bracing studs at door bucks and furring for ceilings.
- Used in conjunction with metal lath and plaster in partitions, ceilings, column and beam enclosures, etc.

### Product Data:

- Available in galvanized meeting ASTM A-568 or Hot-Dipped galvanized meeting ASTM A-653, G60.
- Lengths: 16'0" standard, (other lengths upon request).

Product Number	(A) IN. Size	GA.
CRC-075	.75	16
CRC-100	1.00	16
CRC-150	1.50	16
CRC-200	2.00	16
CRC-250	2.50	16
CRC-300	3.00	18

## Rolled Angles (RA)

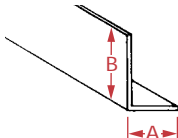

### Uses:

- For 90 degree corner enclosures at lapped framing locations; provides in-plane stability of framework.

### Product Data:

- Available in most sizes, lengths and gauges.

(AxB) Product	Gauges	Length
7/8"x 1-3/8"	25, 22, 20, 18	10'
1-1/2"x 1-1/2"	25, 22, 20, 18, 16	10'
2"x 2"	25, 22, 20, 18, 16, 14	10'
3"x 3", 3"x 6"	20, 18, 16, 14, 12	10'
2"x 4"	20, 18, 16, 14, 12	10'

## Residential Blocking, (KATS)

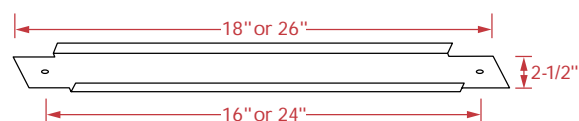

### Uses:

- Component of stud or joist bridging methods.
- Stiffened C-section eases installation compared to flat strapping.
- Reinforced flat surface allows for ease in attachment of fixtures.
- Provides solid support in lieu of wood for attachment of cabinets and handrails.

### Product Data:

- Designations: KAT and spacing.
- Gauges: Heavy or standard galvanized.
- Lengths: 18" and 26".

## Flat Strapping (FS)

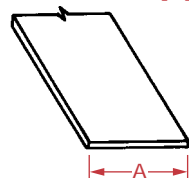

### Uses:

- Provides tension force resistance in shear wall assemblies.
- Resists racking of prefabricated wall assemblies while handling, transporting and erection.

### Product Data:

- Designation: FS width and gauge.
- Widths: 2, 3, 4, 5 and 6" (custom widths and coil available).

## Bridge Clips (BC)

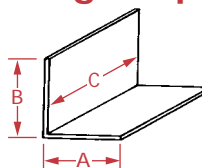

### Uses:

- For alternate screw attachment of CRC bridging to stud webs in lieu of direct weld.

### Product Data:

- Designation: BC length and gage.
- Standard Gage: 14 gauge galvanized steel.
- Standard Length: C-2 1/2", 3 3/8" and 5 1/4".
- Leg Dimensions: A - 1 1/2", B - 1 1/2".

Designed for maximum flexibility as Area Separation Walls, the Series 600 is the most cost-efficient, performance-oriented system.

### METAL COMPONENTS

- Aluminum Angle Clip 
- C Track, Cap, Edge, or End Closure 
- H-Stud 25 Gage 

### Fire and Sound Test References

The design file numbers and the references appearing in this brochure may be cross referenced in the Fire Resistance Design Manual published by the Gypsum Association of the UL and ULC Fire Resistance Directories published by Underwriters Laboratories. The Fire Resistance Design Manual is referenced in the BOCA Basic/National Building Code, the Standard Building Code by SBCCI, and the Uniform Building Code by ICBO.

The data relating to fire and sound-tested assemblies contained herein is based on the characteristics, properties and performance of materials and systems obtained under controlled test conditions as set forth under the appropriate ASTM standard such as E119 (Fire), E90 (Sound) or E72 (Structural).

Prior to installation, the specifier or user should determine that the local Building and Fire Code Authority permits the installation of gypsum Area Separation Walls and that the insuring group will not penalize the owner.

### Installation Instructions

When the wood framed walls of one unit are complete, the Area Separation Walls are constructed before the next unit's interior framing is started. Allow a 3/4" space between the Area Separation Wall and the wood framing.

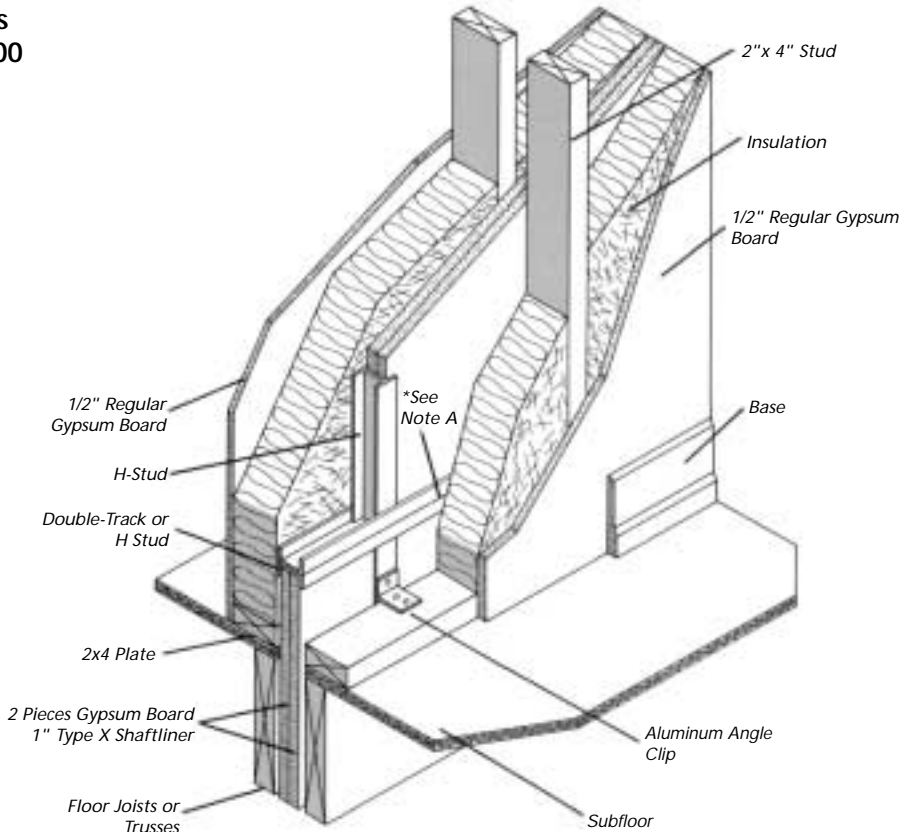

Bottom track is secured to the slab using suitable fasteners at a maximum of 24" o.c. Begin at one end or side with a vertical section of 2" x 10' track. Insert two pieces of 1" Type X Shaftliner. Plumb and secure with a 2" x 2" x 10' H-Stud member. Install gypsum board panels and H-Stud members progressively across the wall and secure to the wood framing with aluminum angle clips.

Aluminum angle clips should be screw-attached to the web of the H-Studs and nailed or screwed to the wood top plates (48" o.c. max.). Attach angle clips to the same H-stud on both sides of the Area Separation Wall. Cap the assembly with either an H-Stud member placed horizontally or two pieces of track fastened back to back. Repeat the process for the next course of

gypsum panels and metal framing up to or through the roofline per plan details. Cap the top of the assembly with 2" track.

Cover all exposed edges or web faces of the metal with 6" wide strips of 1/2" Type X board secured to the metal with 1" Type S drywall screws approximately 12" o.c.

### NOTE A:

As tested, all exposed track and H-Stud members should be covered with 6" wide strips of either 3/4" C or 5/8" Type X, screw-attached 12" o.c.

Some authorities, however, consider the insulation and interior finish as sufficient protection. Please check with your local Building Official or Fire Marshal's office.

## Details Common to all Systems (Modify per Plan Requirements)

STC 35-39

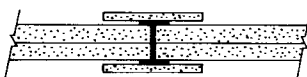

WP-1870

Fire Test Ref:

WHI 495-0743 1-28-86

WHI 495-0744 1-30-86

Structural Data

Thickness: 3"

Weight: 9-1/2" psf

STC 60-64

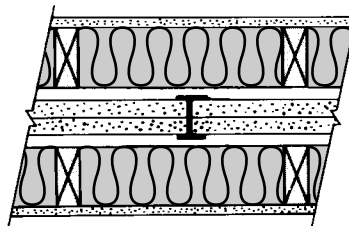

Use Between Interior Wood-Framed Units

STC 60-64

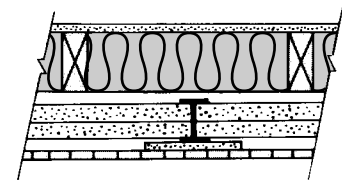

Use As End Wall With Exterior Protective Finish

Series 620 J Track and Slotted C-T Studs are manufactured from hot dipped galvanized steel meeting ASTM A924 and ASTM A653.

The 2 1/2" steel-framing system retains the popular 3 1/2" wall thickness with a 2-hour fire rating to accommodate standard door-framing dimensions. A unique feature of the Series 620 stud is its slotting in the web of the stud. Tests have demonstrated that these slots effectively improve resistance to thermal and noise transmissions.

The 2 1/2" stud provides a 1 1/2" air cavity for services. Studs are friction fitted between top and bottom J Tracks.

Use J Tracks for all closure details, including duct and door openings, abutments, intersections, etc. No other special metal components are required.

However, an alternate vertical J-L corner member is available in 10' and 12' lengths for use in lieu of two J Tracks to form certain outside corner configurations - see detail. Studs are automatically spaced 24" o.c. Maximum with the special Shaftliner panels.

## Helpful Hints

- Use a fastening plate to secure the J Track whenever fasteners are closer than 4" to the edge. Setting the plate at the time of concrete construction will avoid spalling by mechanical fasteners.
- Pre-cut C-T studs 3/4" less than the opening's height.
- In structural steel-frame construction, install J Track sections before applying spray-on fire proofing.
- Items to be anchored to the wall (cabinets, sinks, handrails, etc.) should be fastened to the C-T studs or to plates secured behind or between layers of 1/2" Fireguard® C. Joint compounds should be applied at ambient temperatures above 50°F (10°C) with adequate ventilation.
- For acoustical sealing and prevention of air leakage, use a bead of flexible sealant at the perimeter of each wall under each face layer and under the 2-1/2" flange of J Track for shaft wall finished on one side.
- Use Type S screws for 25 gauge steel framing. Use Type S-12 screws for 20 gauge (or heavier) steel framing.
- It is important that the job structural engineer approve the type, size and maximum spacing of track fasteners to meet the design load requirements.

\* DALE/INCOR is an authorized user of the Typroc® and the Fireguard® registered trademarks.  
\* Registered trademark of Domtar Inc.  
\* Reproduced with the authorization of G-P Gypsum Corp.

## Stud Design Properties

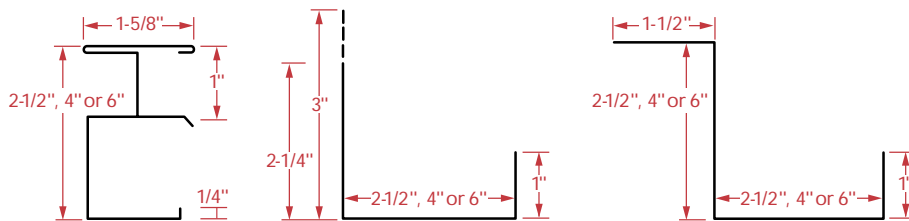

## Minimum C-T Stud Section Properties

Based on AISI "Specifications for the Design of Cold-Formed Steel Structural Members."

T= Minimum uncoated base steel thickness (inches)  $I_x$ = Moment of inertia (inches<sup>4</sup>)  
W= Weight (pounds per linear foot)  $S_x(C)$ = Section modulus "C" flange (inches<sup>3</sup>)  
A= Section area (inches<sup>2</sup>)  $S_x(T)$ = Section modulus "T" flange (inches<sup>3</sup>)

Stud Size	T	W	A	$I_x$	$S_x(C)$	$S_x(T)$
2-1/2" x 25 ga.	0.0179	0.470	0.118	0.132	0.095	0.118
2-1/2" x 20 ga.	0.0329	0.820	0.218	0.242	0.175	0.217
4" x 25 ga.	0.0179	0.580	0.145	0.374	0.171	0.207
4" x 20 ga.	0.0329	1.020	0.267	0.687	0.341	0.380
6" x 25 ga.	0.0179	0.715	0.181	0.957	0.299	0.347
6" x 20 ga.	0.0329	1.260	0.333	1.759	0.543	0.637

1 Hr. Rated Series 621 • 2 Hr. Rated Series 620 or 621 and • 3 Hr. Rated Series 630 or 631

## Limiting Heights - Studs 24"

Stud Depth (in.)	Stud & Track Gauge	Design Deflection Limit	Uniform Load (PSF)			
			5	7.5	10	15
2.5	25	L/120	14'2"	12'5"	11'3"	9'4"
		L/180	12'5"	10'10"	9'10"	8'7"
		L/240	11'3"	9'10"	8'11"	7'10"
		L/360	9'10"	8'7"	7'10"	6'10"
2.5	20	L/120	15'10"	13'10"	12'8"	10'11"
		L/180	13'10"	12'1"	10'11"	9'7"
		L/240	12'8"	10'11"	9'11"	8'8"
		L/360	10'11"	9'7"	8'8"	7'7"
4	25	L/120	19'1"	15'11"	13'10"	11'3"
		L/180	16'8"	14'6"	13'2"	11'3"
		L/240	15'1"	13'2"	12'0"	10'8"
		L/360	13'2"	11'6"	10'6"	9'2"
4	20	L/120	21'8"	18'11"	17'2"	15'0"
		L/180	18'11"	16'6"	15'0"	13'1"
		L/240	17'2"	15'0"	13'8"	11'11"
		L/360	15'0"	13'1"	11'11"	10'5"
6	25	L/120	22'7"	18'9"	16'3"	12'0"
		L/180	19'9"	17'3"	15'8"	12'0"
		L/240	17'11"	15'8"	14'3"	12'0"
		L/360	15'8"	13'8"	12'5"	10'10"
6	20	L/120	27'4"	23'11"	21'8"	19'0"
		L/180	23'11"	21'11"	19'0"	16'7"
		L/240	21'8"	19'0"	17'3"	15'1"
		L/360	19'0"	16'7"	15'1"	13'2"

Test Ref: WHI-495-0206/0225, issued August 4, 1995 deflection limits with adjustment to conform strength and end reaction.

C-T studs and J track are same gauge. Based on minimum safety factor of 1.5 for ultimate bending.

## Track Fastener Shear Loads

Comprehensive design data on this subject may be found in ACWI Steel Framing Systems Manual.

For shear-bearing capacity considerations of the perimeter steel-wall track, the following Table is an expanded version of the ACWI Table - to include 22 and 25 gauge - thick steel with 1/8" and 9/64" diameter fasteners.

For example, an 18' high wall under a design pressure load of 15 psf would require 1/8" diameter fasteners to be spaced 16" o.c. Maximum to avoid exceeding the design shear stress of 25 gauge steel track. In addition, those same 1/8" diameters, driven 3/4" deep in 3000 psi concrete, must be spaced 14" o.c. Maximum to avoid exceeding the design shear stress of the concrete.

Shank Diameter	Steel Thickness				
	16 ga.	18 ga.	20 ga.	22 ga.	25 ga.
1/8"	—	—	310	259	181
9/64"	—	—	349	291	203
5/32"	—	—	388	323	226
11/64"	—	517	427	356	248
3/16"	777	621	460	388	271

Note: It is important that the job engineer approve the type, size and maximum spacing of perimeter fasteners to meet the design load requirements.

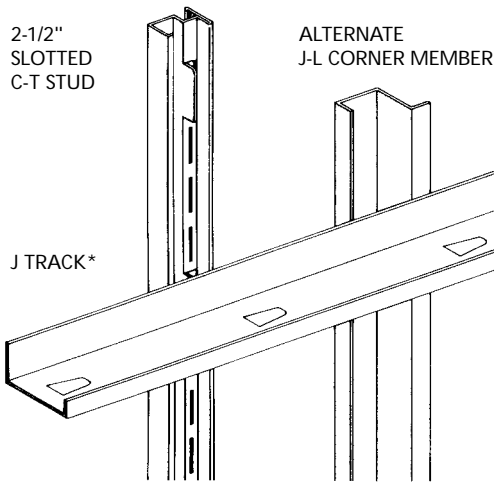

\* Note 3" Leg for 20 Gage with No Tabs

## Procedures

1. Layout per construction drawings. Secure J Track as perimeter framing on floor and plumb to ceiling and sides. Attach with suitable fasteners, spaced not more than 24" o.c. Apply a bead of flexible sealant to the perimeter.
2. Preplan the stud layout 24" o.c. And adjust the spacing at either end so that the terminal stud will not fall closer than 8" from the end.
3. Erect the first 1" Fireguard Shaftliner panel, cut 3/4" less than the total height of the framed section. Plumb the panel flush against the web of the J Track and secure with 1 5/8" type S screws 24" o.c. Or bend out tabs in J Track to secure panels in place.
4. Insert a C-T Stud, also cut 3/4" less than the overall height into the top and bottom J Tracks and fit tightly over the previously installed 1" panel.
5. Install the next 1" Fireguard Shaftliner panel inside the J Tracks and within the tabs of the C-T stud. Note that the edges of the panel are beveled to help guide the panel into the slotted and tabbed section of the stud. Attach each panel to top J Track with three 1 5/8" type S screws.
6. Progressively install succeeding studs and panels as described above until the wall section is enclosed. The final panel section may be secured with 1 5/8" type S screws or tabs from the J Track at 24" o.c.
7. Where wall heights exceed the standard or available length of Shaftliner panels, the panels may be cut and stacked with joints occurring with the top or bottom third points of the wall. Joints of adjacent panels should be alternately staggered to prevent a continuous horizontal joint.
8. For doors, ducts or other large penetrations or openings, install J Track as perimeter framing as detailed. Use 20 gage track with a 3: back leg for elevator doors and block cavity with 12" wide gypsum filler strips for doors exceeding 7'0" height.

## Series 620

A 2-hour fire resistive, nonload-bearing, non-combustible partition designed to enclose shaftways containing elevators, ducts, piping, air shafts and similar construction applications.

The 620 System consists of 1" Toughrock® Fireguard® Shaftliner Panels supported by 2-1/2", 4" or 6" C-T studs and faced on one side with two layers of 1/2" ToughRock Fireguard C Gypsum Board.

### 2-Hour Rated Finished one Side

1/2" facing layers installed horizontally or vertically. Edges and ends offset 24" o.c.

Framing Depth (in.)	2 1/2	4	6
Wall Thickness (in.)	3 1/2	5	7

## Series 621

Designed for use to enclose stairwells, this system is similar to the 620 Series but is finished on both sides with a single layer of 1/2" ToughRock Fireguard C Gypsum Board.

### 2-Hour Rated Finished one Side

1/2" facing layers installed horizontally or vertically. Edges and ends offset 24" o.c.

Framing Depth (in.)	2 1/2	4	6
Wall Thickness (in.)	3 1/2	5	7

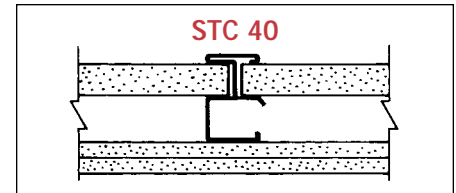

WP 7092\* See WHI Design No. WH U405  
Thickness: 3-1/2"  
Approx. Weight 9psf Sound Test Ref: WHI-0034-2

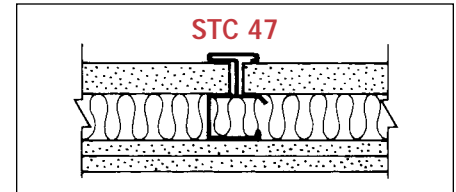

Sound testing using 1" thick glass fiber in cavity

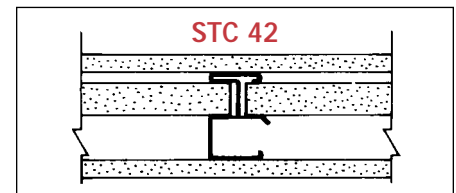

WP 7093\* See WHI Design No. WH U406  
Thickness: 3-1/2"  
Approx. Weight 9psf Sound Test Ref: WHI-0034-2

## 2-Hour Horizontal

### Designs Series 623, 624 & 627

A 2-hour fire-resistive horizontal membranes for use as 2-hour ceiling stair soffit or horizontal duct shaft membrane. The 623 and 627 is built from the bottom and the 624 from the top side.

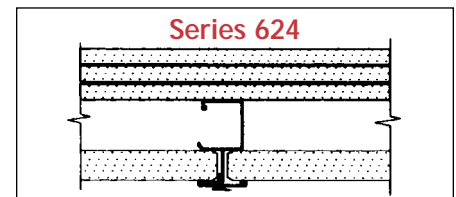
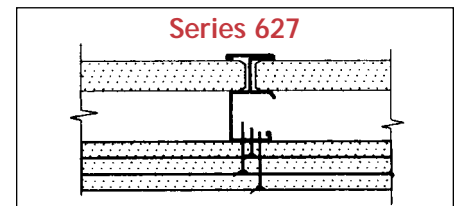
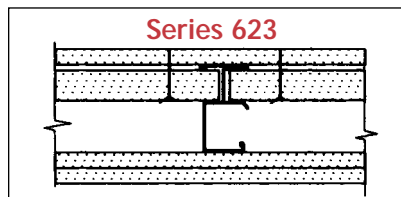

## Maximum Horizontal Spans

*When used as a horizontal membrane the stud length should not exceed those in the following table.*

Stud	Nominal Gauge	Series 622 One Hour*		Series 620 One Hour*		Series 623/624/627 Two Hour*	
		L/240	L/360	L/240	L/360	L/240	L/360
2-1/2"	25	9'4"	8'2"	8'8"	7'7"	8'1"	7'1"
	20	11'1"	9'8"	10'4"	9'0"	9'8"	8'5"
4"	25	13'2"	11'6"	12'4"	10'9"	11'6"	10'0"
	20	15'6"	13'7"	14'7"	12'9"	13'7"	11'10"
6"	25	17'11"	15'8"	16'9"	14'7"	15'7"	13'7"
	20	21'1"	18'6"	19'9"	17'3"	18'6"	16'2"

\* Based on Model Building Code Interpretation for use as corridor ceiling and stair soffits. Steel stress in spans above does not exceed .4Fy. The use of 20 gage J Track is recommended.



## Drywall Corner Bead

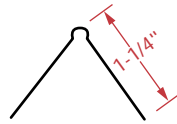
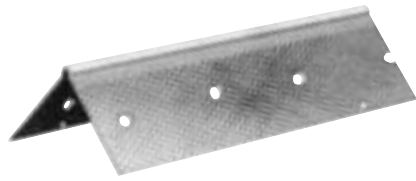

Made of galvanized steel to provide durable protection for drywall external corners. Cement adheres readily to the knurled flanges and keys into the perforations. Exposed nose provides a straight, clean corner definition and guards against impact damage. Standard sizes and lengths are shown in the table below. Specify hot-dipped for moist or humid conditions.

Size/Depth	Length, (ft.)	Pcs./Ctn.	Ft./Ctn.
1-1/4" x 1-1/4"	8', 9', 10'	50	400', 450', 500'
	6'-9'	63	425'

*Other lengths furnished upon request.*

## D-200 Series L-Bead

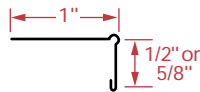

Easily installed, angle-type drywall trim provides finished appearance for wallboard edges at door and window openings. Hemmed edge on front flange adds rigidity and keeps bead straight. Nailing flange is knurled and perforated to aid cement adhesion. Made of galvanized steel in sizes and lengths shown on the table below.

Part No.	Drywall Size	Length, (ft.)	Feet/Ctn.
D-201	1/2"	10'	500'
D-202	5/8"	10'	500'

*D-200 3/8" Drywall size and other lengths furnished upon special order.*

## D-400 Series J-Bead

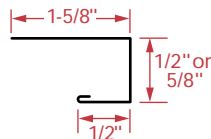
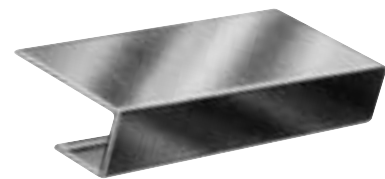

Similar in function to the 200A casing bead, with the added advantage of not requiring treatment of the joint before the wall is finished. Made of galvanized steel in sizes and lengths shown in the table below.

Part No.	Drywall Size	Length, (ft.)	Feet/Ctn.
D-401	1/2"	10'	500'
D-402	5/8"	10'	500'

*D-400 3/8" Drywall size and other lengths furnished upon special order.*

## 200-A Series U-Bead

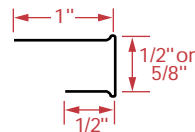
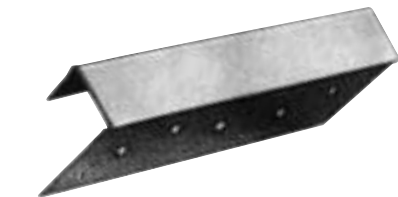

This is a channel type trip that provides a neat protective edge for wallboard at windows and doors. It is also widely used as a terminal at intersections of wallboard and other surfaces. The nailing flange has holes and embossing to improve cement adherence. Made of galvanized steel in sizes and lengths shown in the table below.

Part No.	Drywall Size	Length, (ft.)	Feet/Ctn.
200-A	1/2", 5/8"	10'	500'

*200-A 3/8" Drywall size and other lengths furnished to special order.*

**Dale Industries**  
**Corporate Headquarters**  
6455 Kingsley Avenue  
Dearborn, MI 48126  
1-800-882-STUD (313) 846-9400  
FAX (313) 846-7128

**Dale/Incor**  
**Baltimore, MD**  
4601 North Point Boulevard  
Baltimore, MD 21219  
1-800-345-STUD (410) 477-4000  
FAX (410) 477-1550

**Dale/Incor**  
**Birmingham, AL**  
511 Vulcan Drive, Ste. 109  
Birmingham, AL 35210  
1-800-397-STUD (205) 956-9470  
FAX (205) 956-9625

**Dale/Incor**  
**Ft. Lauderdale, FL**  
1001 Northwest 58th Court  
Ft. Lauderdale, FL 33309  
1-800-330-6303 (954) 772-6300  
FAX (954) 772-7124

**Dale/Incor**  
**Tampa, FL, LLC**  
8419 Sabal Industrial Boulevard  
Tampa, FL 33619  
1-800-237-5130 (813) 623-5504  
FAX (813) 621-7231

**Dale/Incor**  
**Houston, TX, LLC.**  
308 Hughes Street  
Houston, TX 77023  
1-877-606-STUD (713) 681-6808  
FAX (713) 681-7780

e-mail: [info@daleincor.com](mailto:info@daleincor.com) Internet: [www.daleincor.com](http://www.daleincor.com)



Active participants in relevant committees of ASIM and AISI.