



Missouri University of Science and Technology
Scholars' Mine

Center for Cold-Formed Steel Structures Library

Wei-Wen Yu Center for Cold-Formed Steel Structures

01 Jun 1997

Screw and welded connection behavior using structural grade 80 of A653 steel (a preliminary study)

Exaud N. Koka

Wei-wen Yu

Missouri University of Science and Technology, wwy4@mst.edu

Roger A. LaBoube

Missouri University of Science and Technology, laboube@mst.edu

Follow this and additional works at: <https://scholarsmine.mst.edu/ccfss-library>

 Part of the [Structural Engineering Commons](#)

Recommended Citation

Koka, Exaud N.; Yu, Wei-wen; and LaBoube, Roger A., "Screw and welded connection behavior using structural grade 80 of A653 steel (a preliminary study)" (1997). *Center for Cold-Formed Steel Structures Library*. 115.

<https://scholarsmine.mst.edu/ccfss-library/115>

This Technical Report is brought to you for free and open access by Scholars' Mine. It has been accepted for inclusion in Center for Cold-Formed Steel Structures Library by an authorized administrator of Scholars' Mine. This work is protected by U. S. Copyright Law. Unauthorized use including reproduction for redistribution requires the permission of the copyright holder. For more information, please contact scholarsmine@mst.edu.

Civil Engineering Study 97-4
Cold-Formed Steel Series

Fourth Progress Report

**SCREW AND WELDED CONNECTION BEHAVIOR USING
STRUCTURAL GRADE 80 OF A653 STEEL
(A PRELIMINARY STUDY)**

by

Exaud N. Koka
Research Assistant

Wei-Wen Yu
Roger A. LaBoube
Project Directors

**A Research Project Sponsored by
the American Iron and Steel Institute**

June, 1997

Department of Civil Engineering
Center for Cold-Formed Steel Structures
University of Missouri-Rolla
Rolla, Missouri

ABSTRACT

This Fourth Progress Report presents the results of 56 connection tests conducted at the University of Missouri-Rolla during February-April, 1997. The intent of this limited test program was to gain an understanding of the general behavior characteristics of connections in grade 80 steels. No attempt was made to develop an indepth understanding of the connection behavior, which would be necessary to propose complete or comprehensive design recommendations. The performance and behavior of screw and welded connections in low-ductility steel were studied by testing to failure 36 specimens using self-drilling screws, 16 welded connections using either transverse or longitudinal fillet welds, and 4 connections using resistance welds. The material used in this study consisted of ASTM A653 Structural Grade 80 Steel (formerly ASTM A446 Grade E). Test results were compared with the recently approved AISI Specification (1), and other recently published research results (2).

TABLE OF CONTENTS

	Page
ABSTRACT	ii
LIST OF TABLES	v
LIST OF FIGURES	vi
1. INTRODUCTION	1
1.1 GENERAL REMARKS	1
1.2 OBJECTIVE AND SCOPE	1
2. LITERATURE REVIEW	2
2.1 SCREW CONNECTIONS	2
2.2 WELDED CONNECTIONS	3
2.3 BOLTED CONNECTIONS	5
3. EXPERIMENTAL INVESTIGATION	8
3.1 MATERIALS	8
3.2 CONNECTION CONFIGURATIONS	8
3.3 SPECIMEN PREPARATION	9
3.4 TEST PROCEDURE	10
3.5 OBSERVATIONS OF FAILURE MODES	10
3.5.1 Screws in Single Shear	10
3.5.2 Screws in Double Shear	11
3.5.3 Resistance Welds	11
3.5.4 Longitudinal Fillet Welds	12

TABLE OF CONTENTS (CONTINUED)

	Page
3.5.5 Transverse Fillet Welds	12
4. EVALUATION OF TEST RESULTS	12
4.1 SCREW CONNECTIONS IN SINGLE SHEAR	12
4.2 SCREW CONNECTIONS IN DOUBLE SHEAR	15
4.3 WELDED CONNECTIONS	18
4.3.1 Comparison With AISI Predictions	18
5. DESIGN RECOMMENDATIONS	20
6. SUMMARY	21
7. FUTURE RESEARCH WORK	22
ACKNOWLEDGEMENTS	23
REFERENCES	24
APPENDIX	25

LIST OF TABLES

Table		Page
1	Average Material Properties for 22 and 26 Gage Steel	25
2	Measured Dimensions for Screw #10-16, T3	25
3	Tested and Computed Loads for Screw Connections in Single Shear	26
4	Comparison of Single Shear Results	27
5	Comparison of Double Shear Results (Using Full F_u)	28
6	Comparison of Double Shear Results (Using $0.75 F_u$)	29
7	Comparison of Double Shear Results (Using Specified $F_u = 62$ ksi)	30
8	Tested and Computed Fillet Weld Results	31
9	Tested and Computed Results for Resistance Welds	32

LIST OF FIGURES

Figure		Page
1	Connection Configuration for One Screw in Shear	33
2	Connection Configuration for Two Screws in Shear	34
3	Connection Configuration for Three Screws in Shear	35
4	Connection Configuration for Four Screws in Shear	36
5	Mounting the Specimens on the MTS 880 Test Machine	37
6	Connection Configuration for Welded Connection - Resistance Welds	38
7	Connection Configuration for Welded Connection - Fillet Welds	39
8	MTS 880 Test System	40
9	Tilting/Bearing Failure Mode for 22 Gage Connection	40
10	Tilting/Bearing Failure Mode for 26 Gage Connection	41
11	Typical Failed Specimens for Connections in Double Shear	41
12	Typical Failed Specimens for Fillet Welds	42
13	Behavior of Screw Connections in Single Shear	43
14	Load versus Number of Screws for 26 Gage Single Shear Connection	44

1. INTRODUCTION

1.1 GENERAL REMARKS

In the cold-formed steel construction industry today, a common means of fastening is through the use of self-drilling screws or welds. Of particular interest is the use of low-ductility steel with connections using screws or welds as the means of fastening. However, the literature presently available on self-drilling screws or welds as applied to connections using low-ductility steel is limited.

1.2 OBJECTIVE AND SCOPE

The primary objective of the subject study is to conduct a preliminary investigation on the behavior of screw connections using low-ductility steel such as Structural Grade 80 of A653 Steel. An attempt was made to compare the test results to the strength computed by the current AISI design specification (1) and the ones predicted by the equation given by Daudet and LaBoube (2). The notion of load sharing among the screw group also formed the subject of this study. Furthermore, the strength and behavior of welded connections in shear for fillet welds in the transverse and longitudinal directions as well as the shear behavior of resistance welds were briefly investigated.

2. LITERATURE REVIEW

2.1 SCREW CONNECTIONS

The present AISI design criterion on screw connections is based on the collaborative research efforts from the United States, Canada, the Netherlands and Great Britain, as discussed by Pekoz (3). Most recently, Daudet and LaBoube (2) reported the results of 264 shear tests that were conducted on self-drilling screws. The tests conducted included a single screw in single shear, two screws in single shear, and a single screw in double shear. The performance and behavior of self-drilling screws using low-ductility steel were compared with the performance and behavior of screws using more ductile steel. Those results were also compared with the manufacturer's published data, the 1986 AISI Specification with the 1989 Addendum, and the recently approved AISI Specification for self-drilling screws. This study also led to the development of design recommendations for screw connections that can be applied to low-ductility steel. The notion of load sharing within a group of screws within a connection was not addressed in this study. Also, this study was limited to 20 gage (nominal thickness = 0.023-in.) and thicker steel sheets. Thus, the applicability of the design equations derived from this study for thin material, say 22 gage steel sheet and thinner material is questionable.

2.2 WELDED CONNECTIONS

Dhalla and Winter (4) conducted tension tests of longitudinally and transversely welded connections made of A653 Structural Grade 80 Steel ('Z' steel as designated in the reference) as part of an overall research on the ductility requirement for cold-formed steel structural members. The specimens had a thickness of 0.038 inches. The material properties of the steel were as follows:

- * 0.2 % Offset Yield Strength (F_y) = 75.5 ksi - parallel to rolling direction
= 99.4 ksi - perpendicular to rolling direction.
- * Tensile Strength (F_u) = 81.7 ksi - parallel to rolling direction
= 99.8 ksi - perpendicular to rolling direction
- * F_u/F_y ratio = 1.08 - parallel to rolling direction
= 1.00 - perpendicular to rolling direction
- * Elongation in a 2-inch gage length (including necking)
= 4.38 % - parallel to rolling direction
= 1.34 % - perpendicular to rolling direction

For the tests of longitudinal fillet weld connections, the specimens were all loaded in the rolling direction (longitudinal direction). Among the three specimens, two failed in an inclined tearing of sheet outside the fillet weld. The ratios of tensile strength of the connection to the tensile strength of the steel were 0.91 (for lap length of 2.85 inches) and

1.05 (for lap length of 3.75 inches). One specimen failed in shear at the fillet weld (for lap length of 2.50 inches).

For the tests of transverse fillet weld connections, all of the specimens were loaded in the rolling direction (longitudinal direction). A total of eight specimens were tested (two fully welded, two partially welded, two unsymmetrically welded, and two doubly lapped). The ratios of tensile strength of the connection to the tensile strength of the steel were 0.84 and 0.86 for the two fully welded specimens, 0.87 and 0.88 for the two unsymmetrically welded specimens, and 0.84 and 0.86 for the two doubly lapped specimens. The fracture of the two partially welded specimens followed the contour of the partial weld toe and then extended into the unwelded base metal, resulting in higher strength ratios of 0.92 and 0.94. The lower strength ratios of the welded connections were considered to be attributed to the partial annealing of the base metal under the welding heat.

Most of the current design guidelines as provided by the AISI Specification are based on the research findings at Cornell University as summarized by Pekoz and McGuire (5). They summarized a series of tests on different welded connections. The tested strengths of the connections were compared to the calculated strengths. Among all the connections tested, the tests using 24 gage (0.028 inches) and 28 gage (0.019 inches) steel sheets and welded with arc spot (puddle) welds were made of A653 Structural Grade 80 steel. Other tests were made of more ductile steel. The actual tensile strength of the 28 gage sheet steel ranged from 98.0 to 109.8 ksi, and that of 24 gage sheet steel was 107.6 ksi. All of the

calculated strengths of the connections were based on the actual tensile strengths of the steels used. For fourteen 28 gage steel connections welded with single sheet arc spot welds, the ratio of tested to calculated strength of the connections ranged from 0.62 to 1.24, with an average of 0.93 and a standard deviation of 0.200. The failure modes of these fourteen connections were basically sheet bearing, shearing of the sheet behind the weld, and combinations of the two in which the weld plowed toward the end of the sheet. For six 24 gage steel connections welded with single sheet arc spot welds, the ratio of tested to calculated strength ranged from 0.65 to 1.28, with an average of 1.13 and a standard deviation of 0.240. The failure modes of these six connections were similar to those of the 28 gage steel connections. Four 28 gage steel connections welded with double sheet arc spot welds failed in pure shearing in the welds. The ratio of tested to calculated strength of the connections ranged from 0.98 to 1.19, with an average of 1.07 and a standard deviation of 0.090. Three 28 gage steel connections welded with double sheet arc spot welds failed in tearing of the sheets along the contour of the welds with the tearing spreading across the sheet. The ratio of tested to calculated strength ranged from 0.86 to 0.93, with an average of 0.90. This study did not address the behavior of fillet and resistance welds using Structural Grade 80 of A653 steel.

2.3 BOLTED CONNECTIONS

Dhalla and Winter (4) conducted tension tests of single bolted connections made of A653 Structural Grade 80 Steel ('Z' Steel as designated in the reference) as part of an overall

research study on the ductility requirement for cold-formed steel structural members. The specimens had a thickness of 0.038 inches. The average material properties of the steel were as listed in Section 2.2 of this report. For the tests of the single bolted connections, it was found that for the Structural Grade 80 steel in longitudinal direction (nine specimens), failure occurred in a ductile manner as seen in ductile steels, while in the transverse direction (four specimens), the net section of the specimens developed an average of 75% of the predicted ultimate strength and showed a transverse cleavage fracture (semi-brittle manner) rather than a ductile inclined shear fracture. All of the Structural Grade 80 steel connections tended to result in a lower strength ratio (ratio of measured strength in shear, bearing, and net section tearing to the tensile strength of the steel) than other low ductility steel connections (which had a local elongation of 20%) in the test series. When compared to ductile steel connections, shear and bearing strengths of low ductility steel connections were somewhat lower than those of ductile steel connections, but the tensile strength in net section seemed unaffected by the lower ductility. It appeared that local elongation of a steel was important for both shear and bearing strengths of connections. Since local strain in thin sheets may be very large around the fastener at failure due to bearing and shearing, a large local elongation capacity is needed.

Seleim and LaBoube (6), conducted tests on various bolted connections made of cold-reduced low-ductility steels. Their test specimens had thicknesses ranging from 0.040 to 0.070 inches.

The material properties of the steel used were as follows:

- * The average yield strength (F_y) = 70.4 ksi for the 0.040 inch thick steel sheets
= 66.4 ksi for the 0.070 inch thick steel sheets.
- * Average Tensile Strength (F_u) = 76.0 ksi for the 0.04 inch thick steel sheets
= 71.0 ksi for the 0.07 inch thick steel sheets
- * Average F_u/F_y ratio = 1.08 for the 0.040 inch thick steel sheets
= 1.07 for the 0.070 inch thick steel sheets.
- * Average elongation in a 2-inch gage length = 5.64 % for the 0.04 inch thick steel sheets
= 7.43 % for the 0.07 inch thick steel sheets

For the eleven specimens that failed in edge shearing, the ratio of measured ultimate load to predicted load ranged from 1.12 to 1.41 for both thicknesses of the steels tested. The predicted load was determined based on the equations that appear in the 1986 edition of the AISI Specification. Since shearing failure mode involved a small portion of sheet in contact with fastener, the local elongation appeared to play a major part in reaching a high ultimate strength. Also, since this study was limited to bolted connections, its applicability to screw connections is a subject of further research.

3. EXPERIMENTAL INVESTIGATION

3.1 MATERIALS

For this preliminary study, the Structural Grade 80 of A653 steel ranging in thickness from 0.029 in. (22 ga.) to 0.017 in. (26 ga.) was tested. The average material properties as depicted in Table 1 are according to (7). Only one type of screw has been used in this preliminary study. Self-drilling screws are usually specified using a two number system followed by a symbol for the drill point type that is machined into the screw. The first number designates the nominal gage of the screw diameter. The second number indicates how many threads per inch are cut into the shaft of the screw. Therefore, the #10-16, T3 screw used in this study indicates a screw with a 10-gage nominal shaft diameter (0.19 in.), with 16 threads per inch, and a type T3 drill point. The average important dimensions of the screw, namely d , d_h , d_R and d_T were taken as the average of measurements from 10 screws randomly selected from the lot. For the above mentioned symbols, d is the shaft diameter of screw, d_h is the diameter of screw head, d_R is the root diameter of screw shaft, and d_T is the drill tip diameter of the screw. Table 2 shows the measured and average dimensions of a #10-16, T3 screw.

3.2 CONNECTION CONFIGURATIONS

In order to achieve a basic understanding of how a single screw behaves in single shear,

configurations A-1, B-1, C-1, and D-1 in Figures 1 through 4 were tested. The test setup consisted of mounting the specimens in the testing machine as illustrated in Figure 5. For the screw connections in double shear, the configurations A-2, B-2, and C-2 as shown in Figures 1 through 3 were tested. Similarly, for the welded connections, the configurations E-1 and E-2 for resistance welds and F-1 and F-2 for fillet welds as shown in Figures 6 and 7 were tested.

3.3 SPECIMEN PREPARATION

All connection specimens were cut from 4 x 8 ft. sheet steels. Each specimen was then marked to indicate the gage and test number. For the weld connection tests, cleaning of the surfaces was done using sandpaper in order to ensure proper fusion of the weld metal. A total of sixty test assemblies were fabricated and tested for this experimental investigation. This allowed for the testing of identical tests of the different connection types. The purpose of fabricating identical test assemblies of the different connection geometries was to provide consistent results in identical connection types. A third identical test was performed when two identical tests varied by more than 10% with respect to the ultimate load. All the screw connection tests used #10-16, T3 screws. The average dimensions of screw #10-16,T3 are shown in Table 2.

3.4 TEST SETUP AND PROCEDURE

All tests were conducted using the MTS 880 test system, pictured in Figure 8. The connection test specimens were inserted into the top and bottom grips of the hydraulic system of the MTS machine. The machine was adjusted to zero and the load mechanism activated at a predetermined speed. The load was applied at a constant rate until failure. No attempt was made to define failure based on a given amount of deflection or screw tilt. Instead, failure was defined by the inability of the connection to carry additional loading. For the majority of the test specimens tested, the test was conducted until the screw tore completely through the hole (screw in double shear), or the steel sheets became dislodged due to excessive screw tilting (single shear). Three identical specimens were tested for the screw connections and two identical specimens were tested for the welded connections.

3.5 OBSERVATIONS OF FAILURE MODES

3.5.1 Screws in Single Shear

For screws in single shear, there was one failure mode. This failure mode, typical for the 22 gage and 26 gage, was a combination of screw tilting and bearing failure in the steel sheet. This failure mode was characterized by the onset of screw tilting at about 75% of the ultimate capacity. At about 85% of the ultimate capacity, screws would exhibit significant tilting. At some point after 90% of the ultimate capacity, sheet separation would begin due

to the drill tip end of the screw slipping out of the enlarged hole. This occurred thread by thread until the screw could no longer hold load. Tilting/bearing failure mode is shown in Figures 9 and 10. It was observed during the test that for multiple rows of screws, the first row suffered a greater amount of deformation than the subsequent rows.

3.5.2 Screws in Double Shear

Screws in double shear were tested by using configurations A-2, B-2 and C-2, as shown in Figures 1 through 3. The edge distance and the spacing of each specimen were more than 3 times the nominal diameter of the screw as specified by the AISI Specification. Figure 11 illustrates typical failed specimens. All of the specimens were tested until the screw completely pulled through the material as is shown in Figure 11. Although the specimens met the AISI edge distance requirements of $3d$, the failure was characterized by bearing followed by longitudinal shear failure of the sheet.

3.5.3 Resistance Welds

Resistance welds were tested by using configurations E-1 and E-2, as shown in Figure 6. The specimens were fabricated in the Civil Engineering Department machine shop using 26 gage sheet steel. The failure mode consisted of combined shear plus tearing of metal along the fused area.

3.5.4 Longitudinal Fillet Welds

Longitudinal fillet welds in shear were tested using configuration F-1, as shown in Figure 7, where longitudinal means that the load is applied parallel to the length of the welds. From the structural efficiency point of view, longitudinal fillet welds are stressed unevenly along the weld due to varying deformations. Failure was characterized by tearing of connected sheets along, or close to, the contour of the welds. This is depicted in Figure 12.

3.5.5 Transverse Fillet Welds

Transverse fillet welds in shear were tested by using the configuration F-2 on Figure 7, where transverse means that the load is applied perpendicular to the length of the weld. Failure was characterized by tearing of connected sheets along the contour of the welds, as shown in Figure 12.

4. EVALUATION OF TEST RESULTS

4.1 SCREW CONNECTIONS IN SINGLE SHEAR

4.1.1 Comparison with the AISI Predictions

Tables 3 and 4 summarize the results of tested and computed failure loads for the single

shear tests. It was noted during testing that the predominant failure mode was bearing combined with screw tilting. Indeed, previous studies (2) have shown that screws subjected to single shear for ductile and low ductility steels generally failed in one of the two ways or a combination thereof, as illustrated in Figure 13. The values: P_T , P_{comp} , P_1 , P_2 , and P_3 , listed in Tables 3 and 4 are defined as follows: P_T is the failure load of the specimen obtained from the test, P_{comp} is the failure load computed from the recommended equation developed by Daudet and LaBoube (2) for single shear, P_1 corresponds to the failure load determined from Section E4 of the current AISI Specification using full F_u , P_2 corresponds to the AISI failure load using $0.75F_u$ and P_3 is the AISI failure load utilizing the specified $F_u = 62$ ksi. In order to normalize the data, the dimensionless quantities, P_T/P_1 , P_T/P_2 , P_T/P_3 , P_T/P_{comp} , are defined in Table 4. The following AISI equations were used to calculate the ultimate capacity due to tilting/bearing failure of screws for the single shear connection, P_1 :

$$P_{AISI} = 4.2 (t^3 d)^{1/2} F_u \quad (4.1)$$

$$P_{AISI} = 2.7 t d F_u \quad (4.2)$$

where:

d = average screw diameter

t = thickness of sheet steel

F_u = steel sheet tensile strength

Thus, Eq.4.1 checks tilting requirements, while Eq. 4.2 checks bearing. Out of the twenty-one screw connection tests that were conducted for single shear, the ratio of P_T/P_1 ranged from 0.714 to 0.964, with an average of 0.84 and a coefficient of variation equal to 8.6%. The plot of load versus number of screws shown in Figure 14 revealed that the graph flattens at the top for large number of screws. This means that the load distribution on a screw group is not linear and that the load does not distribute equally as it is normally assumed in the current AISI Specification. However, this discrepancy is well taken care of by using the reduced material properties ($0.75F_u$ and $F_u = 62$ ksi respectively).

4.1.2 Comparison with Daudet and LaBoube Equations

The study by Daudet and LaBoube (2), used both ductile and low ductile steels in the range from 0.029 in. (20 ga.) to 0.098 in. (12 ga.) in thickness. The following equation was developed to calculate the nominal shear capacity for a single self-drilling screw in single shear.

$$P_n = C_F F_u d^2 (2.4607 t/d - 0.1232) \quad (4.3)$$

Where

t = steel thickness

d = nominal screw diameter

F_u = steel tensile strength

F_y = steel yield strength

$C_F = 1.01$ when: $1.08 < F_u / F_y \leq 1.61$

$C_F = -1.878(F_u / F_y)^2 + 5.2083 (F_u / F_y) - 2.4703$ when: $F_u / F_y \leq 1.08$

The elongations (based on a 2-inch gage length) for the steel sheets that were used in the test program ranged from 44 % for the normal ductile steel to 4 % for the low-ductility steel. Equation (4.3) is applicable for self-drilling screws with characteristics similar to those outlined in Table 2. In addition, the above equations are limited to connecting steel sheets with individual thickness greater than 0.029 in. and less than 0.098 in. The applicability of the equations for steel thicknesses less than 0.029 inches is valid since in Table 4, the ratio $P_T / P_{comp.}$ is approximately equal to 1.0. Out of the twenty one tests that were conducted for screw connections in single shear, the ratio of $P_T / P_{comp.}$ ranged from 0.858 to 1.219, with an average of 1.02 and a coefficient of variation of 10.3%. This shows that Equation (4.3) agrees reasonably well with the test results.

4.2 SCREW CONNECTIONS IN DOUBLE SHEAR

4.2.1 Comparison with the AISI Equations

Tables 5, 6 and 7 summarize the results of tested and computed failure loads for the double shear tests. Table 5 is computed using full F_u , while Table 6 is computed using $0.75F_u$ and Table 7 used the specified $F_u = 62\text{ksi}$. It was observed during the tests that the

predominant failure mode was longitudinal shear failure of sheet. This failure mode is illustrated in Figure 11. Previous studies (2) showed that shearing for low-ductility specimens started to take place once the total length of the hole reached about 1.5 times the original hole diameter. The values of: P_T , P_{comp} , and P_{AISI} , as listed in Tables 5, 6 and 7 respectively, are defined as follows: P_T is the failure load of the specimen obtained from tests, P_{comp} is the failure load obtained using the recommended equation developed by Daudet and LaBoube (2) for a single screw in double shear, and P_{AISI} corresponds to the failure load obtained from the current AISI Specification. In order to normalize the data, the dimensionless quantities, P_T/P_{AISI} and P_T/P_{comp} are defined in Tables 5, 6 and 7. A comparison of the double shear test results with the AISI screw provisions does not seem very meaningful. The reasons for this conclusion is because AISI does not include provisions for screw connections in double shear. Therefore, a comparison was made for the double shear results with Sections E3.1 and E3.3 (Table E3.3-2) of the AISI provisions for bolts, as given by the following equations :

$$P_n = t e F_u \quad (4.4)$$

$$P_n = 3.0 t d F_u \quad (4.5)$$

Where

P_n = nominal resistance per bolt

e = the distance measured in the line of force from
the center of a standard hole to the nearest edge

distance of adjacent hole or to end of connected part

t = thickness of thinnest connected part

F_u = tensile strength of the connected part

F_{sy} = yield point of the connected part

Based on Eqs. (4.4) and (4.5), the smaller value of P_n will control the design. As shown in Tables 5, 6 and 7, if full F_u is used in the above equations, the average ratio of P_T/P_{AISI} is 0.775 with a coefficient of variation of 17.3%. Using 0.75 F_u , the average ratio 1.034 with a coefficient of variation of 17.3%. Also by using the specified $F_u = 62\text{ksi}$ in the equations, the average is 1.377 with a coefficient of variation of 14.9%. These statistics indicate that the current design provisions using 0.75 F_u or $F_u = 62\text{ksi}$ for the prediction of the strength of double shear connections for A653 Grade 80 steel are conservative.

4.2.2 Comparison with Daudet and LaBoube Predictions

The study by Daudet and LaBoube (2) on screw connections in double shear, developed the following equations for computing the nominal shear capacity per single self-drilling screws in double shear:

$$P_{Eqn.} = F_b d t (0.5866 F_u / F_y + 0.2915) \quad (4.6)$$

Where:

$$F_b = 3.1563 F_u$$

For the 15 screw connection tests that were conducted for double shear, the average ratio of P_T/P_{comp} is 0.821 with a coefficient of variation equal to 16.9 when full F_u was used in Equation (4.6) above.

4.3 WELDED CONNECTIONS

4.3.1 Comparison with the AISI Predictions

Tables 8 and 9 give a summary of the test results for welded connections. Table 8 (a) gives test results for longitudinal fillet welds, while Table 8 (b) gives test results for transverse welds. The values of P_T and P_{AISI} represent the tested failure load and the corresponding predicted load using the AISI equations. In most cases, the higher strength of the weld metal prevents weld shear failure, therefore, the provisions of the AISI Specification are based on sheet tearing. For the fillet weld tests done in this program, the tearing occurred in the sheet material rather than in weld. In order to normalize the data, the dimensionless quantities, P_T/P_1 , P_T/P_2 , and P_T/P_3 , are defined in the table. The following AISI equations were used to calculate the nominal shear strength, P_1 , P_2 , and P_3 of fillet weld connections:

(a) For Longitudinal Loading: (where P_{AISI} is either of P_1 , P_2 , or P_3)

$$\text{For } L/t < 25 \quad P_{AISI} = (1 - 0.01L/t) t L F_u \quad (4.7)$$

$$\text{For } L/t \geq 25 \quad P_{AISI} = 0.75 t L F_u \quad (4.8)$$

(b) For Transverse Loading: (where P_{AISI} is either of P_1 , P_2 , or P_3)

$$P_{AISI} = t L F_u \quad (4.9)$$

Where:

t = least value of t_1 or t_2

L = measured length of fillet weld

t_1 = thickness of thinner plate

t_2 = thickness of thicker plate

The longitudinal weld test results show that for the eight tests that were conducted, the ratio, P_T / P_{AISI} , ranges from 0.79 to 1.646 with averages ranging from 0.826 to 1.470 and a coefficient of variation ranging from 3.29% to 5.767%. The transverse weld test results show that for the 8 tests that were conducted, the ratio, P_T / P_{AISI} , ranged from 0.818 to 1.856 with averages ranging from 0.929 to 1.672 and a coefficient of variation ranging from 7.63% to 9.07%. For both the longitudinal and transverse weld tests conducted in this

preliminary study, a relatively good correlation is observed between the tested ultimate capacity and the computed capacity based on the present AISI Specification provisions by using $0.75F_u$.

Table 9 gives a summary of the test results for resistance welds conducted on structural Grade 80 of A653 steel. The variable, P_T , which corresponds to the tested failure load for resistance welds is given in the table. P_{AISI} is also given in the table which was obtained from Table E2.6 of the AISI Specification, where intermediate values were obtained by interpolation. The ratio, P_T/P_{AISI} , varies from 0.960 to 1.141 with an average of 1.05 and a coefficient of variation equal to 6.6%. The test data agrees fairly well with the AISI Specification.

5. DESIGN RECOMMENDATIONS

Based on the observations of failure modes and the evaluation of the tests of 36 screw connections and 20 welded connections, the following preliminary design recommendations may be drawn for the design of connections using low-ductility steel such as Structural Grade 80 of A653 steel.

1. For screw connections in single shear, the connection can be designed according to Section E4.3 of the AISI Specification provided that the tensile strength, F_u , used for determining the nominal strength, P_{ns} , is taken as $0.75F_u$ or 62 ksi,

whichever is less.

2. For screw connections in double shear, the nominal resistance per screw can be determined by the smaller capacity of Sections E3.1 and E3.3 of the AISI Specification provided that the tensile strength, F_u , used for determining the nominal strength, P_n , is taken as $0.75F_u$ or 62 ksi, whichever is less.
3. For welded connections using fillet welds and resistance welds, the connection can be designed according to Sections E2.4 and E2.6 of the AISI Specification respectively, by using $0.75F_u$ or 62 ksi, whichever is less, for the tensile strength of the steel sheet.

6. SUMMARY

In this preliminary study on the screw and welded connection behavior using Structural Grade 80 of the A653 steel, a total of 56 test specimens were conducted, which included 36 tests on screw connections and 20 tests on welded connections. Based on the evaluation of the test results for screw and welded connections, the current AISI design provisions using $0.75F_u$ or the specified $F_u = 62$ ksi are slightly conservative estimates of the nominal capacity of a connection using Structural Grade 80 of the A653 steel. Additional study would be needed if more appropriate design criteria are desired.

7. FUTURE RESEARCH WORK

The research work reported herein is the fourth phase of an overall research project on the Strength of Flexural Members using Structural Grade 80 of A653 Steels, sponsored by the American Iron and Steel Institute. The scale of the test assemblies and the variability of the parameters considered in this preliminary study limited the scope of the present investigation. Additional tests for both single and double shear connections are needed for using different screw types and different materials to investigate pull-out and pull-over strengths, along with the case of multiple screws. This will lead to additional test data for developing any new design criteria for screw connections if necessary.

ACKNOWLEDGEMENTS

The research work reported herein was conducted at the Department of Civil Engineering of the University of Missouri-Rolla under the sponsorship of the American Iron and Steel Institute. Drs. Wei-Wen Yu and R. A. LaBoube are the co-directors of the project.

The financial assistance granted by the Institute and the technical guidance provided by members of Subcommittee 24 - Flexural Members of the AISI Committee on the Specification for the Design of Cold-Formed Steel Structural Members and the AISI Staff (D. F. Boring, R. B. Haws, H. Chen, K. C. Slaughter, and S. P. Bridgewater) are gratefully acknowledged. The Subcommittee members are: J. N. Nunnery (Chairman), R. E. Albrecht, R. L. Brockenbrough, R. E. Brown, C. R. Clauer, D. S. Ellifritt, S. J. Errera, J. M. Fisher, T. V. Galambos, M. Golovin, G. J. Hancock. A. J., Harrold, R. B. Haws, R. B. Heagler, D. L. Johnson, W. E. Kile, R. A. LaBoube, M. R. Loseke, R. Madsen, T. H. Miller, T. M. Murray, T. B. Pekoz, D. C. Perry, R. M. Schuster, P. A. Seaburg, W. L. Shoemaker, T. Sputo, T. W. Trestain, and W. W. Yu.

The steel sheet materials used for the test specimens were kindly donated by Wheeling Corrugating Company, Wheeling, West Virginia. Mr. F. C. Rosenberger from Wheeling-Pittsburg Steel Corporation Steubenville Plant and Mr. R. E. Brown from the Wheeling Corrugating Company are acknowledged for their technical advice.

Thanks are also due to J. J. Bradshaw, J. M. McCracken, and Steve Gabel, staff of the Department of Civil Engineering, for their technical support.

REFERENCES

1. American Iron and Steel Institute., "Specification for the Design of Cold-Formed Steel Structural Members", 1996 Edition.
2. Daudet R. L. and LaBoube, R. A., "Shear Behavior of Self-Drilling Screws in Low Ductility Steel", Proceedings of the 13th International Specialty Conference on Cold-Formed Steel Structures, St. Louis, Missouri, October, 1996.
3. Pekoz, T., "Design of Cold-Formed Steel Screw Connections", Proceedings of the Tenth International Specialty Conference on Cold-Formed Steel Structures, St. Louis, Missouri, October 1990.
4. Dhalla, A. K. and Winter, G., "Influence of Ductility on the Structural Behavior of Cold-Formed Steel Members", Report No. 336, Cornell University, June, 1971.
5. Pekoz, T. and McGuire, W., "Welding of Sheet Steel", Report SG 79-2, Committee of Sheet Steel Producers, AISI, January, 1979.
6. Seleim, S. S. and LaBoube, R. A., "Behavior of Low Ductile Steels in Cold-Formed Steel Connections", Journal of Thin-Walled Structures, Vol. 25, Nov. 2, Elsevier Science Ltd., 1996.
7. Wu, S., Yu, W. W., and LaBoube, R. A., "Strength of Flexural Members Using Structural Grade 80 of A653 and Grade E of A611 Steels", First Progress Report, Civil Engineering Study 95-5, Department of Civil Engineering, University of Missouri-Rolla, Rolla, MO, 1995.

APPENDIX

TABLE 1 AVERAGE MATERIAL PROPERTIES FOR 22 AND 26 GAGE STEEL

Specimen	Thickness t [in.]	0.2% Offset Yield Strength F _y [ksi]	Tensile Strength F _u [ksi]	Tensile to Yield Ratio F _u /F _y	Elongation in 2-in. Gage Length (%)
22 GAGE	0.029	103.9	107.7	1.04	3.67
26 GAGE	0.017	112.5	115.9	1.03	2.40

TABLE 2 MEASURED DIMENSIONS FOR SCREW #10-16, T3

d [in.]	d _h [in.]	d _r [in.]	d _T [in.]
0.1878	0.3106	0.138	0.155
0.1888	0.3108	0.137	0.155
0.1877	0.3106	0.138	0.155
0.1877	0.3107	0.138	0.156
0.1878	0.3106	0.137	0.154
0.1878	0.3107	0.139	0.155
0.1879	0.3106	0.138	0.156
0.1878	0.3106	0.138	0.156
0.1879	0.3109	0.139	0.158
0.1879	0.3107	0.138	0.157
AVERAGE VALUES			
0.1879	0.31068	0.138	0.1557

TABLE 3 TESTED AND COMPUTED LOADS FOR SCREW CONNECTIONS IN SINGLE SHEAR

Specimen Designation	Connection Type	t [in.]	P [lb]				
			P_T	P_1	P_2	P_3	$P_{comp.}$
TA-22G-SS-1-1	A-1	0.029	908	968	726	557	860
TA-22G-SS-1-2	A-1	0.029	912	968	726	557	860
TA-22G-SS-1-3	A-1	0.029	933	968	726	557	860
TA-22G-SS-2-1	B-1	0.029	1554	1936	1452	1114	1720
TA-22G-SS-2-2	B-1	0.029	1549	1936	1452	1114	1720
TA-22G-SS-2-3	B-1	0.029	1618	1936	1452	1114	1720
TA-22G-SS-3-1	C-1	0.029	2690	2904	2178	1671	2580
TA-22G-SS-3-2	C-1	0.029	2647	2904	2178	1671	2580
TA-22G-SS-3-3	C-1	0.029	2597	2904	2178	1671	2580
TA-26G-SS-1-1	A-1	0.017	355	468	351	250	341
TA-26G-SS-1-2	A-1	0.017	376	468	351	250	341
TA-26G-SS-1-3	A-1	0.017	426	468	351	250	341
TA-26G-SS-2-1	B-1	0.017	752	936	702	500	682
TA-26G-SS-2-2	B-1	0.017	791	936	702	500	682
TA-26G-SS-2-3	B-1	0.017	789	936	702	500	682
TA-26G-SS-3-1	C-1	0.017	1217	1404	1053	750	1023
TA-26G-SS-3-2	C-1	0.017	1236	1404	1053	750	1023
TA-26G-SS-3-3	C-1	0.017	1196	1404	1053	750	1023
TA-26G-SS-4-1	D-1	0.017	1334	1872	1404	1000	1364
TA-26G-SS-4-2	D-1	0.017	1344	1872	1404	1000	1364
TA-26G-SS-4-3	D-1	0.017	1362	1872	1404	1000	1364

- Notes :
- screw tilting combined with bearing failure in the steel sheet.
 - Onset of screw tilting at about 75% of the ultimate shear capacity
 - P_T = Tested failure Load for the specimens
 - P_1 = Computed failure load using AISI Specification with full F_u
 - P_2 = Computed failure load using AISI Specification with $0.75F_u$
 - P_3 = Computed failure load using AISI Specification with specified $F_u = 62\text{ksi}$
 - P_{comp} = Computed failure load based on reference [2]

TABLE 4 COMPARISON OF SINGLE SHEAR RESULTS

Specimen Designation	Connection Type	t [in.]	P_T/P_1	P_T/P_2	P_T/P_3	P_T/P_{comp}
TA-22G-SS-1-1	A-1	0.029	0.938	1.251	1.630	1.090
TA-22G-SS-1-2	A-1	0.029	0.942	1.256	1.637	1.010
TA-22G-SS-1-3	A-1	0.029	0.964	1.285	1.675	1.033
TA-22G-SS-2-1	B-1	0.029	0.803	1.070	1.395	0.860
TA-22G-SS-2-2	B-1	0.029	0.800	1.067	1.391	0.858
TA-22G-SS-2-3	B-1	0.029	0.831	1.114	1.452	0.896
TA-22G-SS-3-1	C-1	0.029	0.921	1.235	1.610	0.993
TA-22G-SS-3-2	C-1	0.029	0.906	1.215	1.584	0.977
TA-22G-SS-3-3	C-1	0.029	0.889	1.192	1.554	0.956
TA-26G-SS-1-1	A-1	0.017	0.760	1.011	1.420	1.219
TA-26G-SS-1-2	A-1	0.017	0.805	1.214	1.504	1.169
TA-26G-SS-1-3	A-1	0.017	0.912	1.214	1.704	1.196
TA-26G-SS-2-1	B-1	0.017	0.805	1.071	1.504	1.008
TA-26G-SS-2-2	B-1	0.017	0.847	1.127	1.582	1.060
TA-26G-SS-2-3	B-1	0.017	0.845	1.124	1.578	1.052
TA-26G-SS-3-1	C-1	0.017	0.867	1.190	1.623	1.087
TA-26G-SS-3-2	C-1	0.017	0.882	1.174	1.648	1.105
TA-26G-SS-3-3	C-1	0.017	0.854	1.136	1.595	1.069
TA-26G-SS-4-1	D-1	0.017	0.714	0.950	1.334	0.894
TA-26G-SS-4-2	D-1	0.017	0.719	0.957	1.344	0.901
TA-26G-SS-4-3	D-1	0.017	0.729	0.970	1.362	0.913
AVERAGE			0.84	1.13	1.53	1.02
COV (%)			8.6	8.8	7.4	10.3

**TABLE 5 COMPARISON OF DOUBLE SHEAR RESULTS
(USING FULL F_u)**

Specimen Designation	Connect. Type	t [in.]	P [lb]			P_T/P_{AISI}	$P_T/P_{comp.}$
			P_T	P_{AISI}	$P_{comp.}$		
TA-22G-DS-1-1	A-2	0.029	1549	1761	1670	0.880	0.928
TA-22G-DS-1-2	"	"	1489	1761	1670	0.846	0.892
TA-22G-DS-1-3	"	"	1549	1761	1670	0.880	0.928
TA-22G-DS-2-1	B-2	"	3166	3522	3340	0.899	0.948
TA-22G-DS-2-2	"	"	2788	3522	3340	0.792	0.835
TA-22G-DS-2-3	"	"	2928	3522	3340	0.831	0.877
TA-22G-DS-3-1	C-2	"	4715	5283	5010	0.892	0.941
TA-22G-DS-3-2	"	"	4696	5283	5010	0.889	0.937
TA-22G-DS-3-3	"	"	4722	5283	5010	0.894	0.943
TA-26G-DS-1-1	A-2	0.017	823	1111	1040	0.741	0.791
TA-26G-DS-1-2	"	"	792	1111	1040	0.713	0.762
TA-26G-DS-1-3	"	"	862	1111	1040	0.776	0.829
TA-26G-DS-2-1	B-2	"	1177	2222	2080	0.530	0.566
TA-26G-DS-2-2	"	"	1140	2222	2080	0.513	0.548
TA-26G-DS-2-3	"	"	1230	2222	2080	0.554	0.591
AVERAGE						0.775	0.821
COV (%)						17.3	16.9

Note: - All specimens failed due to a combination of bearing and shearing of sheet steel.

- P_{AISI} = Smaller of the computed failure load based on Eqs. (4.4) and (4.5)

- P_{comp} = Computed failure load based on reference [2]

**TABLE 6 COMPARISON OF DOUBLE SHEAR RESULTS
(USING $0.75F_u$)**

Specimen Designation	Connect. Type	t [in.]	P [lb]		P_T/P_{AISI}
			P_T	P_{AISI}	
TA-22G-DS-1-1	A-2	0.029	1549	1321	1.173
TA-22G-DS-1-2	"	"	1489	1321	1.127
TA-22G-DS-1-3	"	"	1549	1321	1.173
TA-22G-DS-2-1	B-2	"	3166	2642	1.198
TA-22G-DS-2-2	"	"	2788	2642	1.055
TA-22G-DS-2-3	"	"	2928	2642	1.108
TA-22G-DS-3-1	C-2	"	4715	3963	1.190
TA-22G-DS-3-2	"	"	4696	3963	1.185
TA-22G-DS-3-3	"	"	4722	3963	1.192
TA-26G-DS-1-1	A-2	0.017	823	833	0.988
TA-26G-DS-1-2	"	"	792	833	0.951
TA-26G-DS-1-3	"	"	862	833	1.035
TA-26G-DS-2-1	B-2	"	1177	1666	0.706
TA-26G-DS-2-2	"	"	1140	1666	0.684
TA-26G-DS-2-3	"	"	1230	1666	0.738
AVERAGE					1.034
COV (%)					17.3

**TABLE 7 COMPARISON OF DOUBLE SHEAR RESULTS
(USING SPECIFIED $F_u = 62\text{ksi}$)**

Specimen Designation	Connect. Type	t [in.]	P [lb]		P_T/P_{AISI}
			P_T	P_{AISI}	
TA-22G-DS-1-1	A-2	0.029	1549	1014	1.528
TA-22G-DS-1-2	"	"	1489	1014	1.468
TA-22G-DS-1-3	"	"	1549	1014	1.528
TA-22G-DS-2-1	B-2	"	3166	2028	1.561
TA-22G-DS-2-2	"	"	2788	2028	1.375
TA-22G-DS-2-3	"	"	2928	2028	1.444
TA-22G-DS-3-1	C-2	"	4715	3042	1.550
TA-22G-DS-3-2	"	"	4696	3042	1.544
TA-22G-DS-3-3	"	"	4722	3042	1.552
TA-26G-DS-1-1	A-2	0.017	823	594	1.386
TA-26G-DS-1-2	"	"	792	594	1.283
TA-26G-DS-1-3	"	"	862	594	1.451
TA-26G-DS-2-1	B-2	"	1177	1188	0.991
TA-26G-DS-2-2	"	"	1140	1188	0.960
TA-26G-DS-2-3	"	"	1230	1188	1.035
AVERAGE					1.377
COV (%)					14.94

TABLE 8 TESTED AND COMPUTED FILLET WELDS RESULTS**(a) Longitudinal welds**

Specimen Designation	Connect. Type	L_1 [in.]	b_{plate} [in.]	t [in.]	P [lb.]				P_T/P_1	P_T/P_2	P_T/P_3
					P_T	P_1	P_2	P_3			
W - FL - 01	F-1	1.01	2.0	0.029	3857	4732	3549	2724	0.815	1.087	1.416
W - FL - 02	F-1	1.00	"	0.029	3960	4685	3514	2697	0.845	1.127	1.468
W - FL - 03	F-1	0.92	"	0.017	2160	2719	2033	1455	0.794	1.063	1.485
W - FL - 04	F-1	0.86	"	0.017	2019	2542	1907	1360	0.800	1.059	1.485
W - FL - 05	F-1	0.73	"	0.029	2817	3420	2565	1969	0.824	1.098	1.431
W - FL - 06	F-1	0.66	"	0.029	2612	3092	2319	1780	0.845	1.126	1.327
W - FL - 07	F-1	0.47	"	0.017	1118	1389	1042	743	0.805	1.073	1.505
W - FL - 08	F-1	0.48	"	0.017	1249	1419	1064	759	0.880	1.174	1.646
AVERAGE									0.826	1.101	1.470
COV (%)									3.29	3.342	5.767

(b) Transverse welds

Specimen Designation	Connect. Type	L_2 [in.]	b_{plate} [in.]	t [in.]	P [lb.]				P_T/P_1	P_T/P_2	P_T/P_3
					P_T	P_1	P_2	P_3			
W - FT - 09	F-2	1.05	2.0	0.029	2692	3279	2459	1888	0.821	1.095	1.426
W - FT - 10	F-2	0.95	"	0.029	2882	2967	2225	1708	0.971	1.295	1.687
W - FT - 11	F-2	1.00	"	0.017	1774	1970	1478	1054	0.901	1.200	1.683
W - FT - 12	F-2	1.02	"	0.017	1821	2010	1508	1075	0.906	1.208	1.694
W - FT - 13	F-2	0.485	"	0.029	1559	1515	1136	872	1.029	1.372	1.788
W - FT - 14	F-2	0.525	"	0.029	1751	1640	1230	944	1.068	1.424	1.856
W - FT - 15	F-2	0.49	"	0.017	883	965	724	516	0.915	1.220	1.711
W - FT - 16	F-2	0.51	"	0.017	822	1005	754	537	0.818	1.090	1.531
AVERAGE									0.929	1.238	1.672
COV (%)									9.06	9.07	7.63

Notes for Table 8 (a) and (b): - L_1 and L_2 = measured lengths of longitudinal and transverse welds
- P_T = Tested failure load of the specimens
- P_1 , P_2 , and P_3 = Computed failure loads using Full F_u , 0.75 F_u and the specified $F_u = 62$ ksi, respectively.

TABLE 9. TESTED AND COMPUTED RESULTS FOR RESISTANCE WELDS

Specimen Designation	Connect. Type	t [in.]	b _{plate} [in.]	Avg. dia. of weld (in.)	P [lb.]		P _T /P _{AISI}
					P _T	P _{AISI}	
W-G26-S-03	E-1	0.017	''	0.222	428	375	1.141
W-G26-S-04	E-1	0.017	''	0.247	410	375	1.093
W-G26-S-07	E-2	0.017	''	0.246	720	750	0.960
W-G26-S-08	E-2	0.017	''	0.212	763	750	1.017
AVERAGE							1.05
COV (%)							6.6

Note for Table 9: Failure Mode - shear of welds in the fused area for the sheet steel material
 - combined shear plus tearing of metal sheet along fused area.

Connection Type A-1

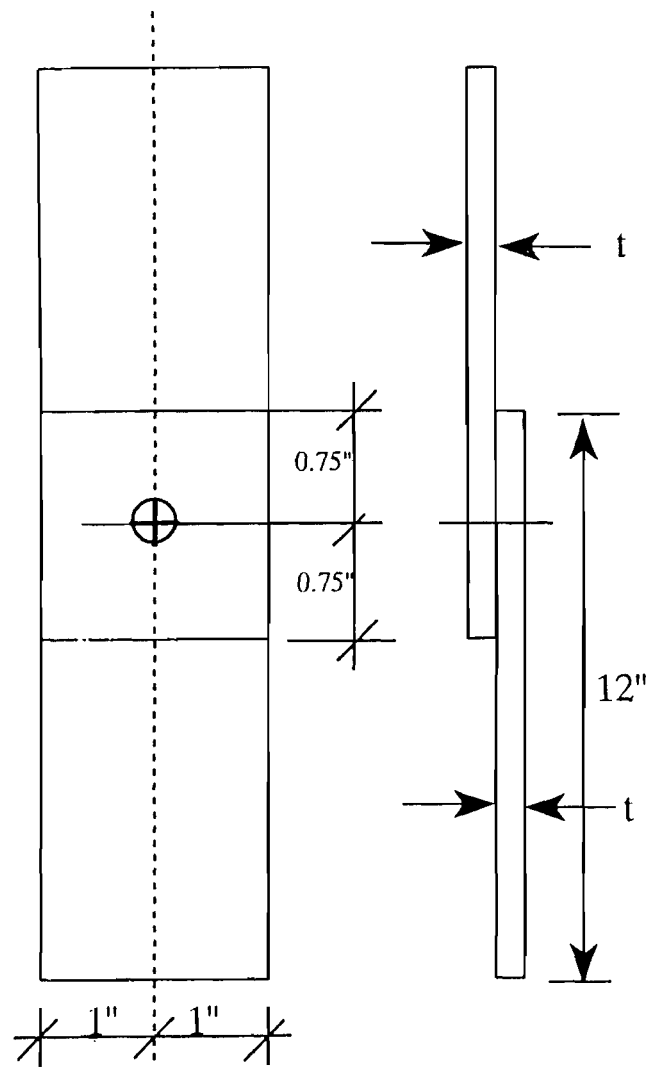

Connection Type A-2

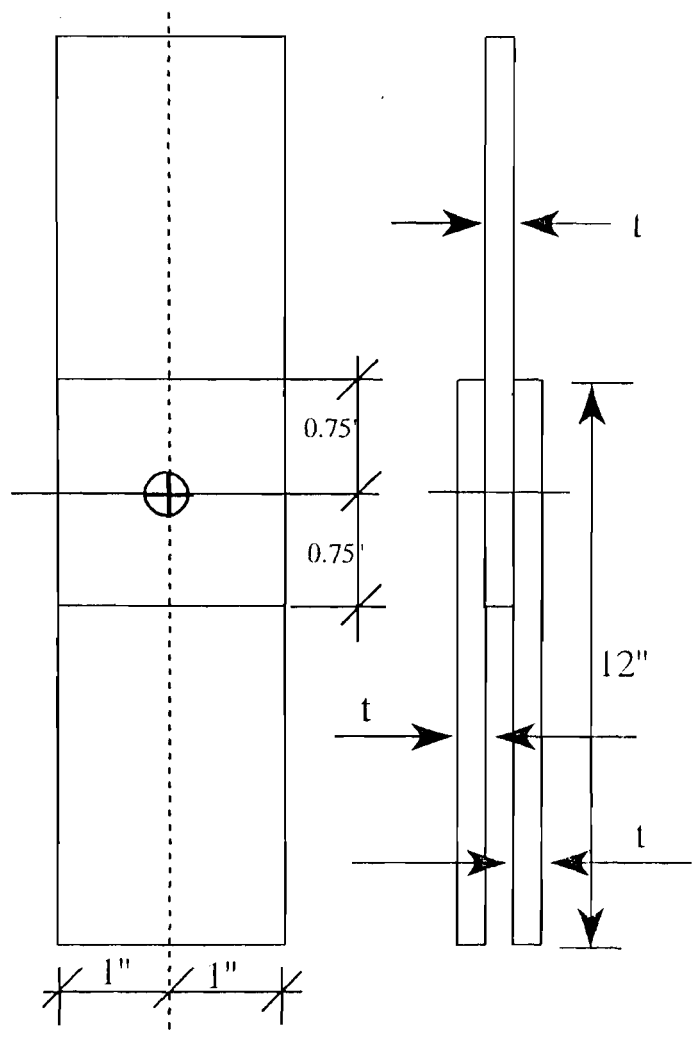
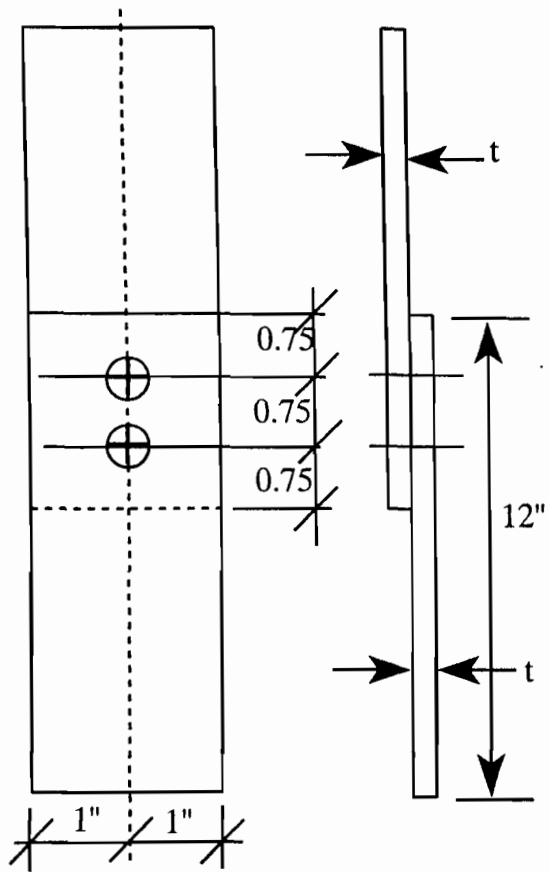

Figure 1. Connection Configuration for One Screw in Shear.

Connection Type B-1



Connection Type B-2

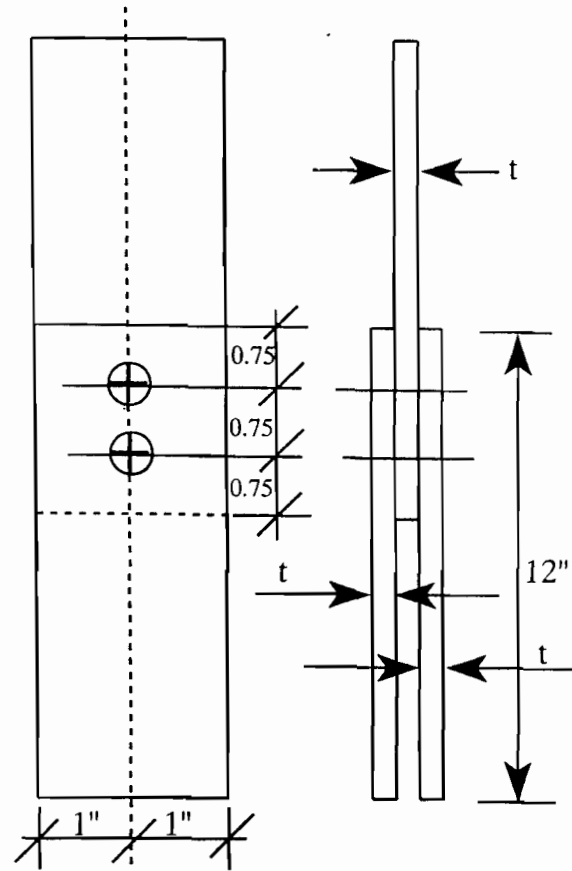

Figure 2. Connection Configuration for Two Screws in Shear.

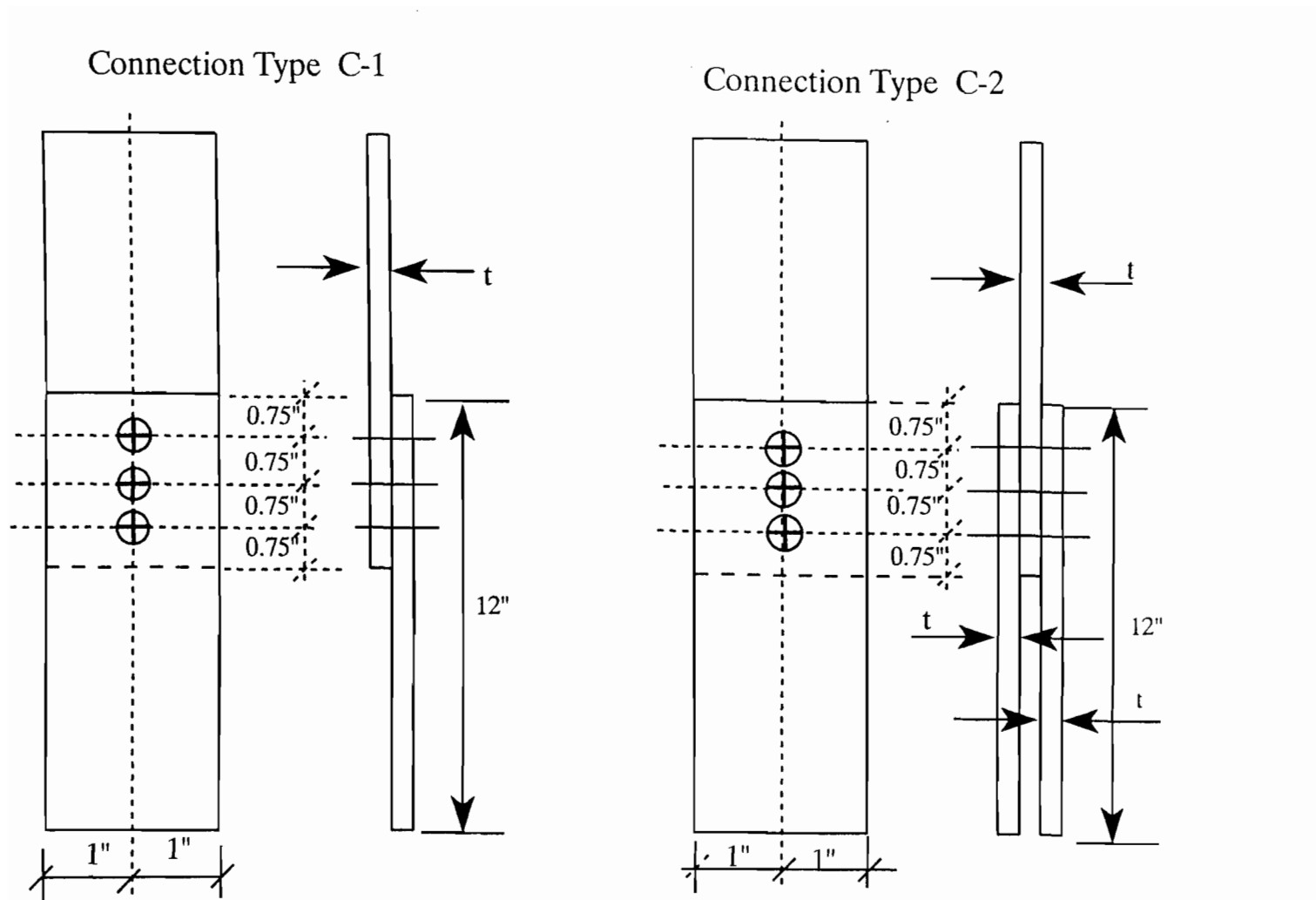

Figure 3. Connection Configuration for Three Screws in Shear

Connection Type D-1

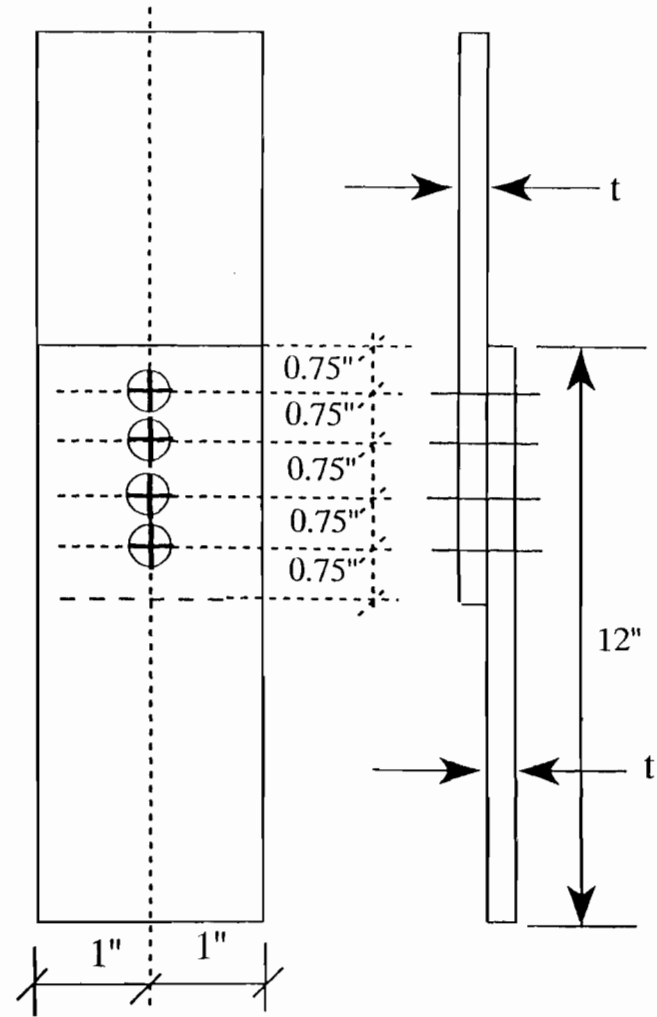

Figure 4. Connection Configuration for Four Screws in Shear.

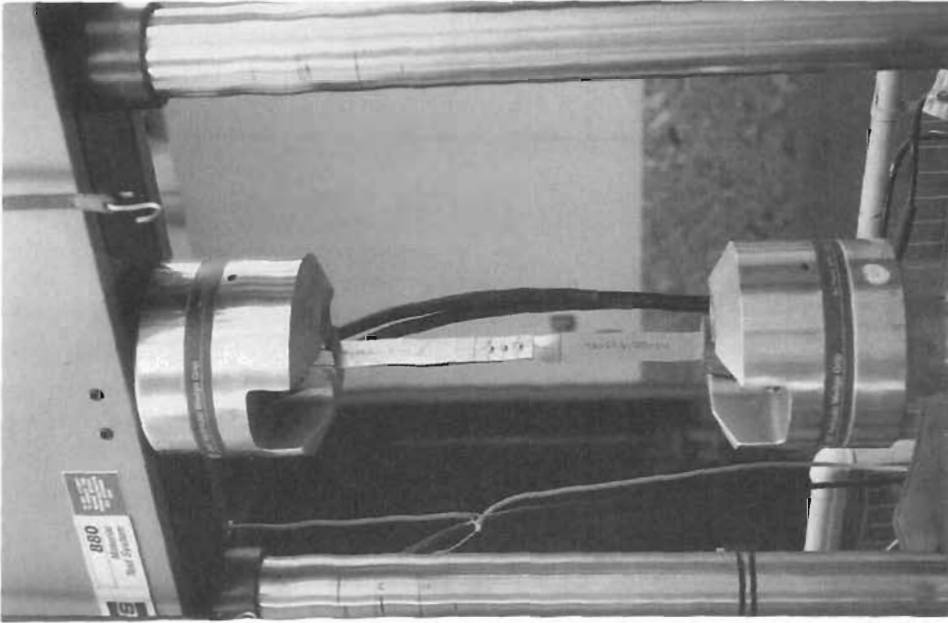

Figure 5. Mounting of the Specimen on the MTS 880 Testing Machine.

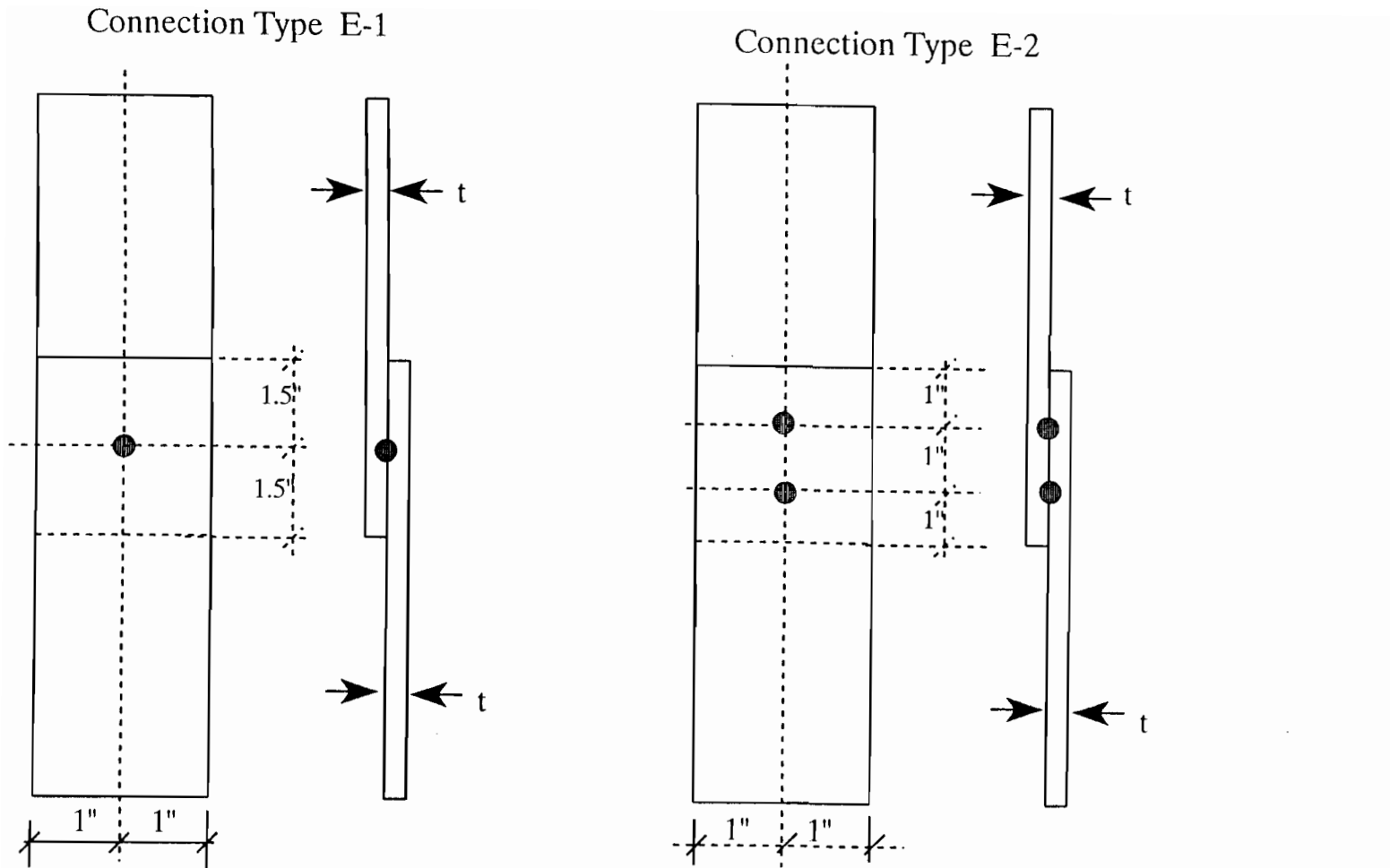

Figure 6. Connection Configuration for Welded Connection - Resistance Welds.

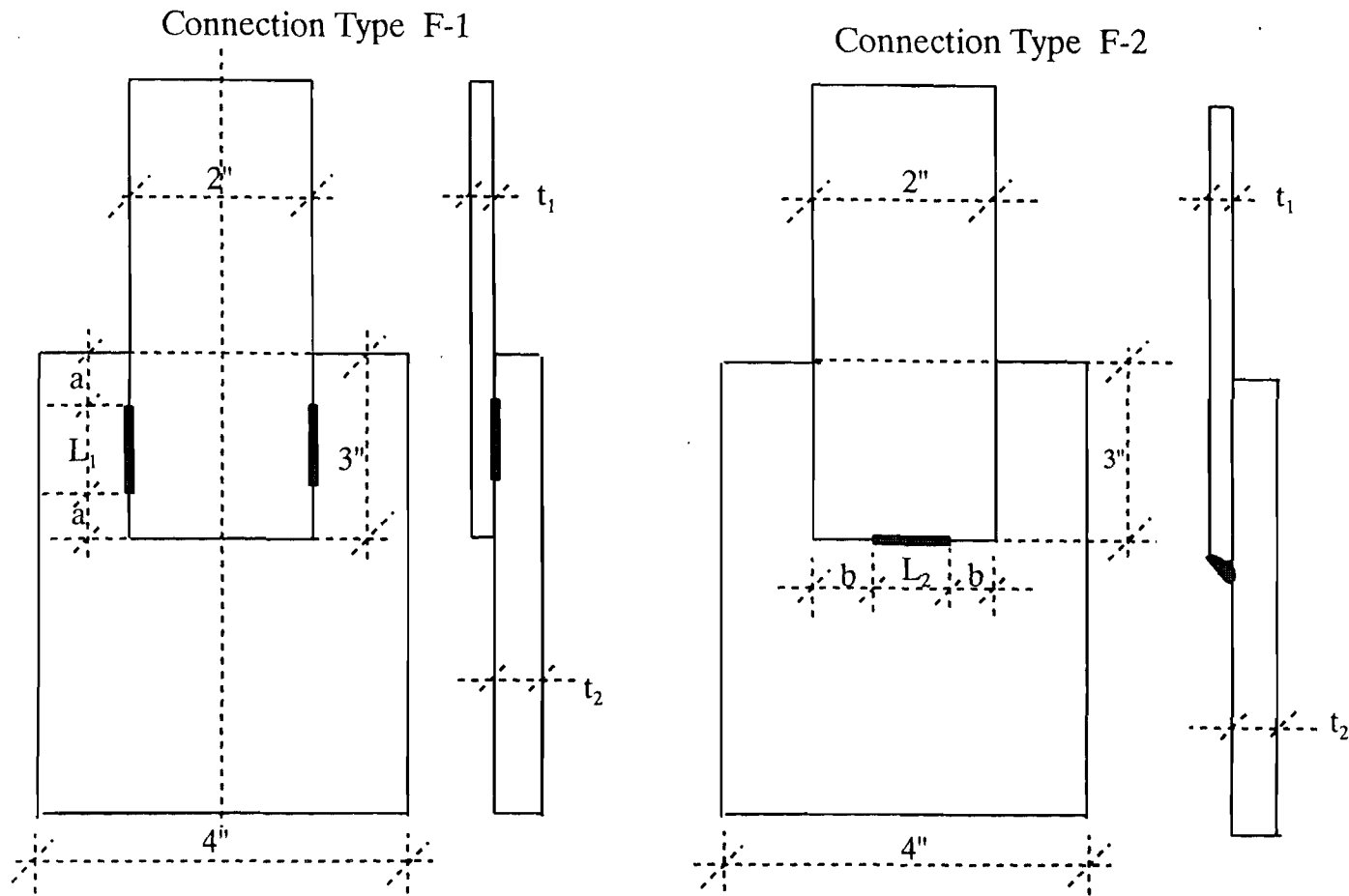

Figure 7. Connection Configuration for Welded Connection - Fillet Welds

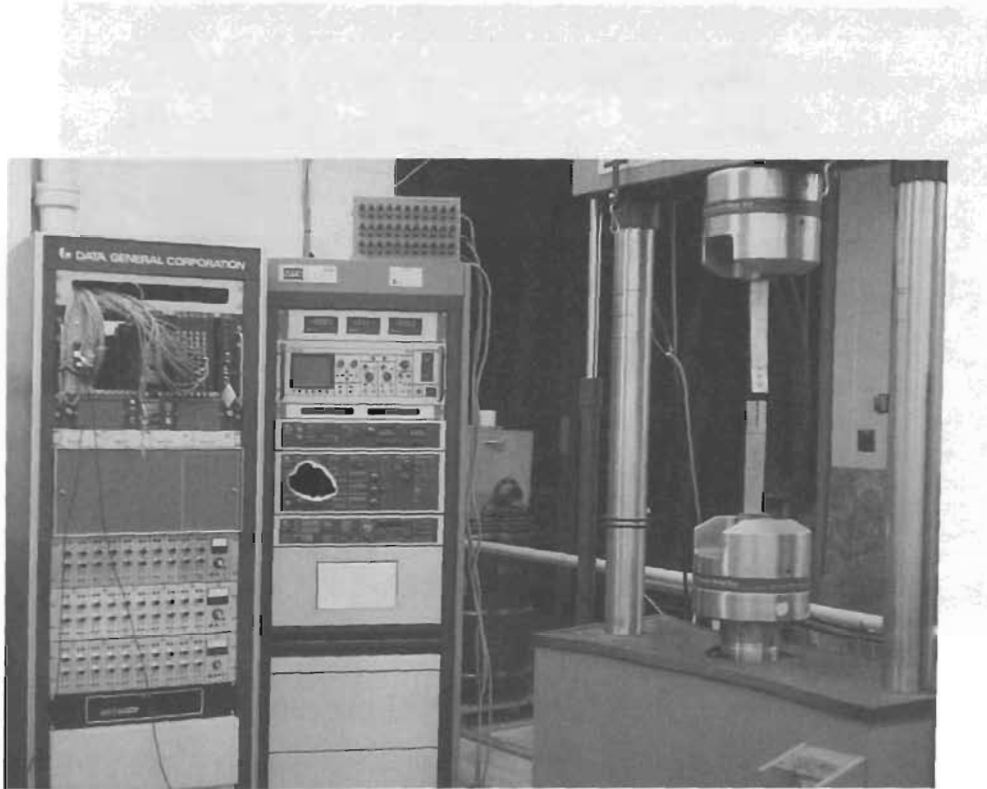

Figure 8. MTS 880 Test System

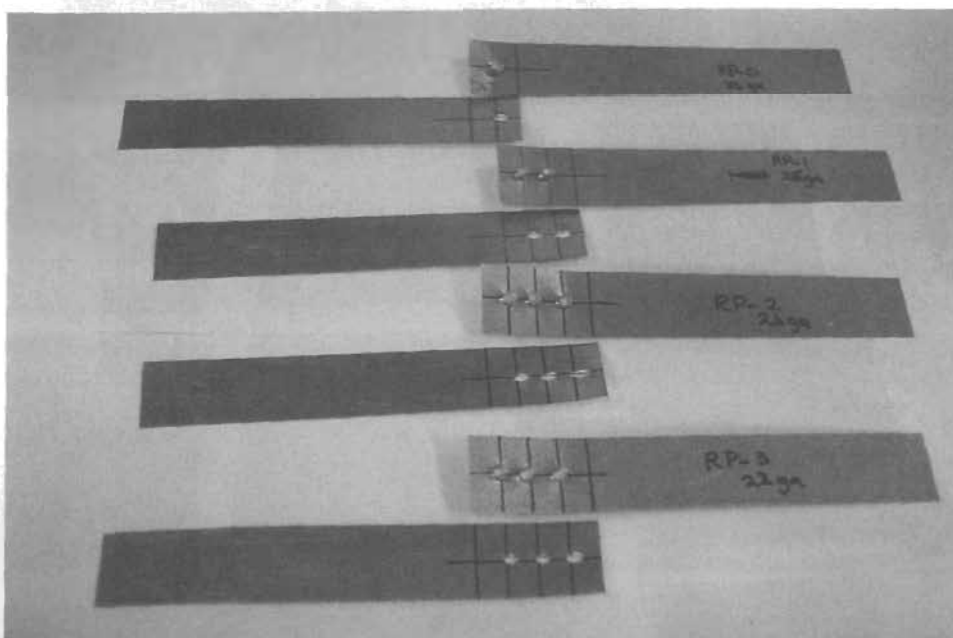

Figure 9. Tilting/Bearing Failure Mode for 22 Gage Connection

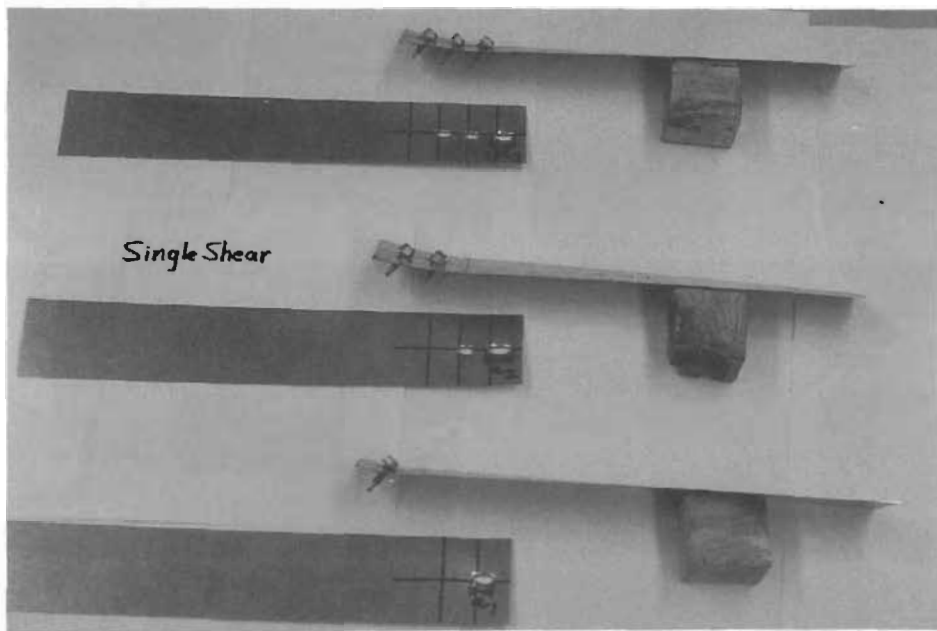

Figure 10. Tilting/Bearing Failure Mode for 26 Gage Connection.

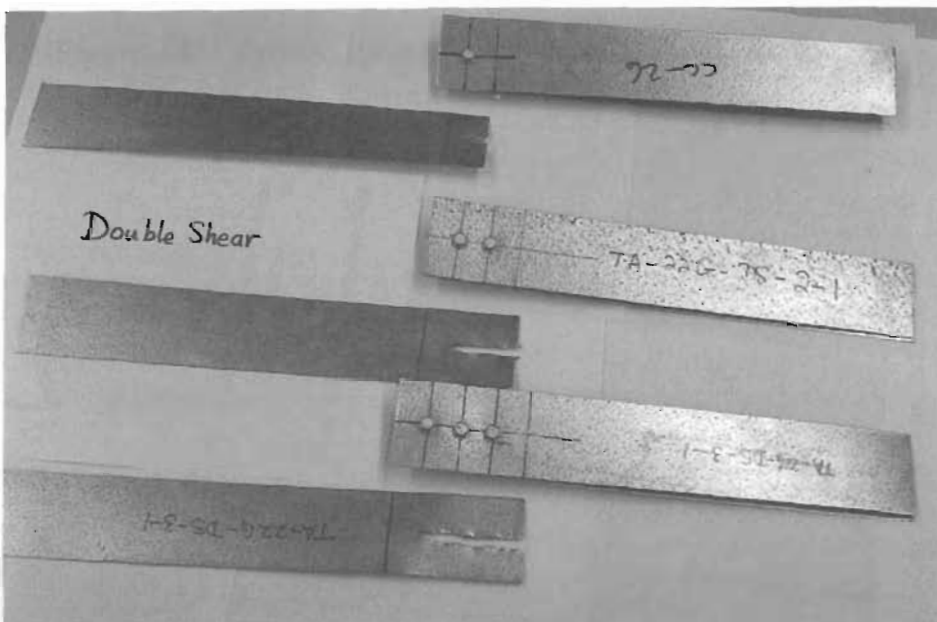

Figure 11. Typical Failed Specimens for Connections in Double Shear

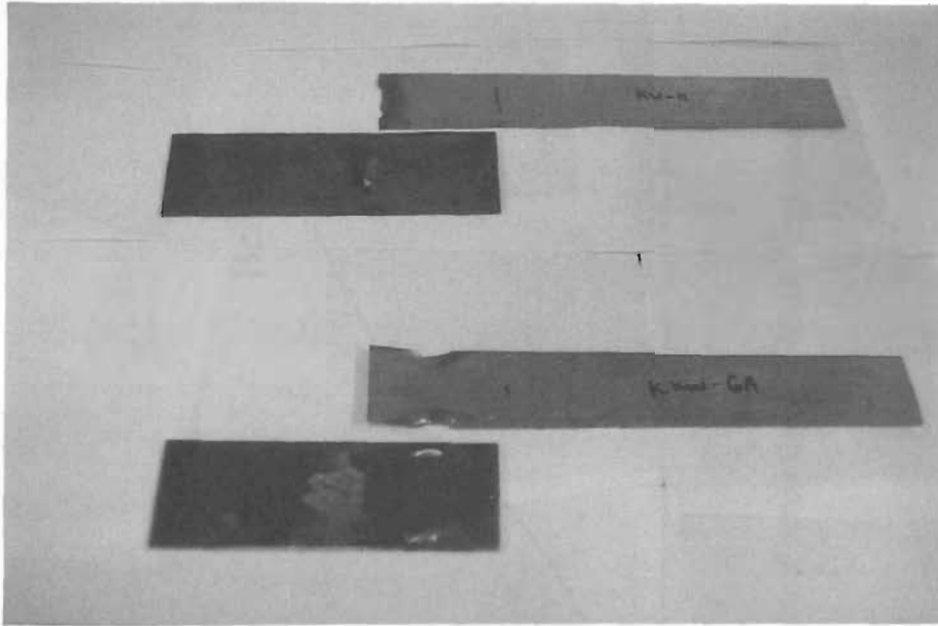

Figure 12. Typical Failed Specimens for Fillet Welds

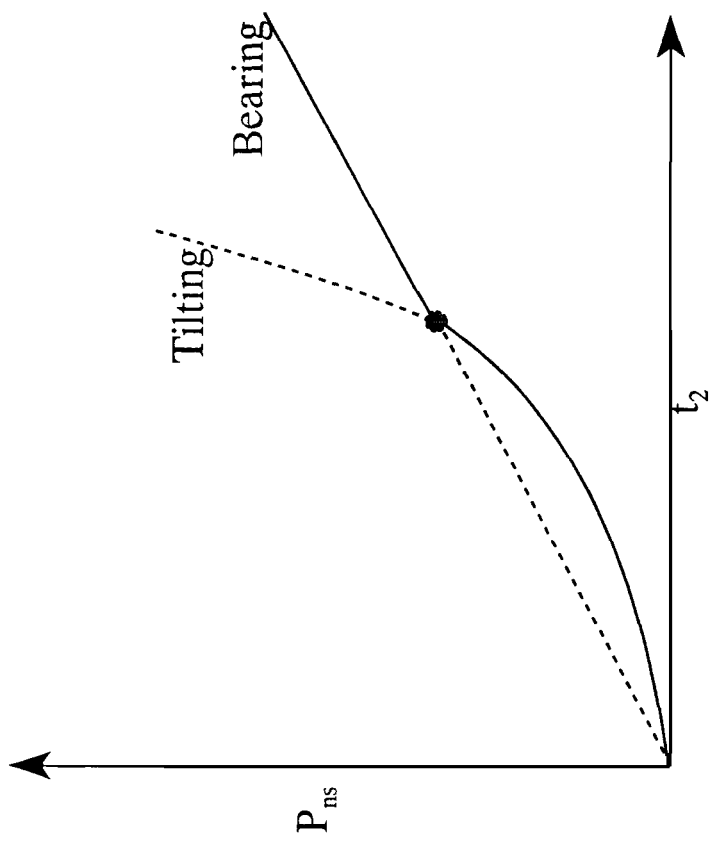

Figure 13. Behavior of Screw Connections in Single Shear

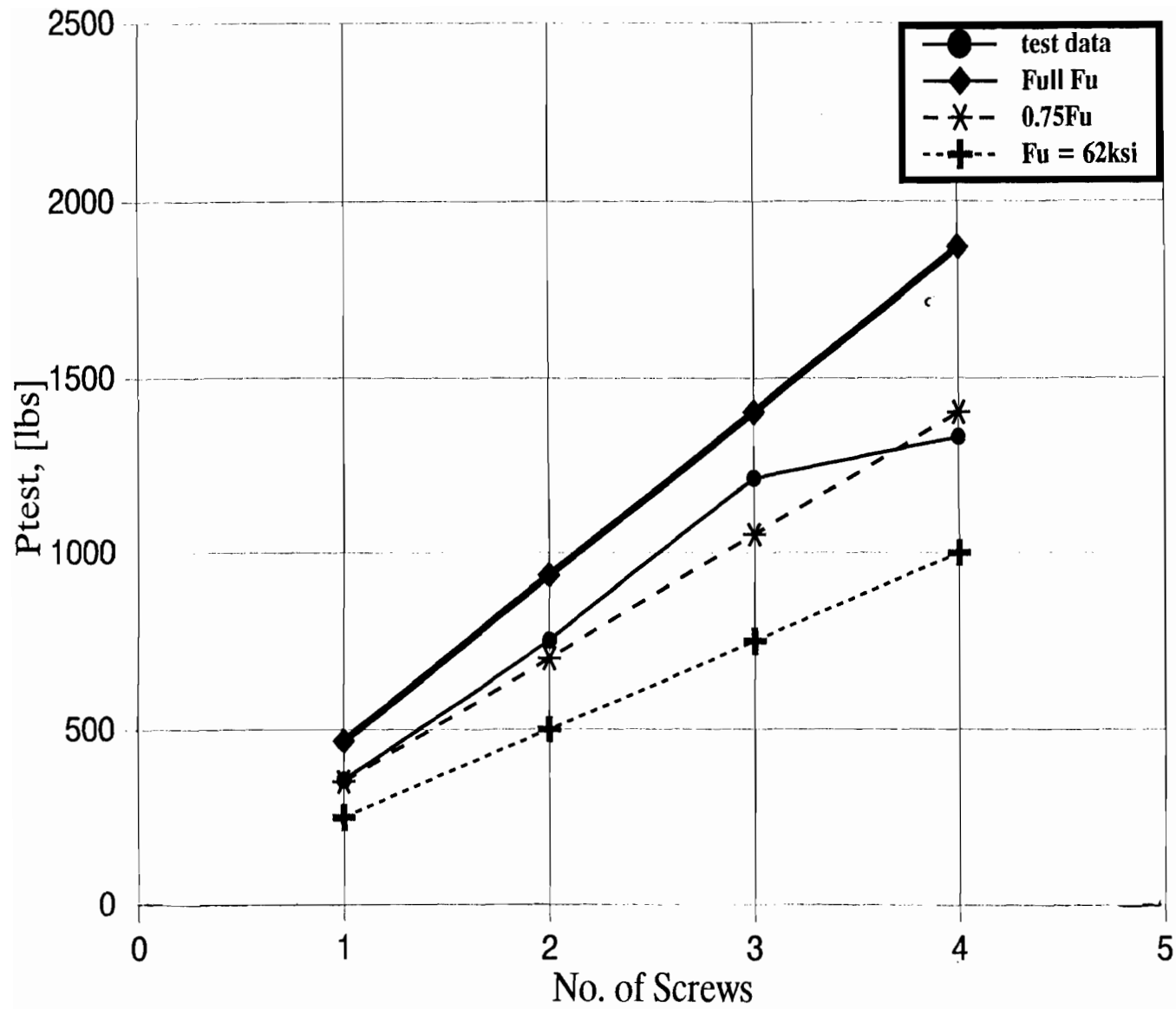

Figure 14. Load versus Number of Screws for 26 Gage Single Screw Connection