

01 Aug 1972

## Analysis of multistory frames with light gauge steel panel infills

Craig J. Miller

Robert G. Sexsmith

Arthur H. Nilson

Follow this and additional works at: <https://scholarsmine.mst.edu/ccfss-library>



Part of the [Structural Engineering Commons](#)

---

### Recommended Citation

Miller, Craig J.; Sexsmith, Robert G.; and Nilson, Arthur H., "Analysis of multistory frames with light gauge steel panel infills" (1972). *Center for Cold-Formed Steel Structures Library*. 103.  
<https://scholarsmine.mst.edu/ccfss-library/103>

This Technical Report is brought to you for free and open access by Scholars' Mine. It has been accepted for inclusion in Center for Cold-Formed Steel Structures Library by an authorized administrator of Scholars' Mine. This work is protected by U. S. Copyright Law. Unauthorized use including reproduction for redistribution requires the permission of the copyright holder. For more information, please contact [scholarsmine@mst.edu](mailto:scholarsmine@mst.edu).

CCFSS LIBRARY Craig Jeffery Miller Robert G.  
22 1 \* 138 Sexsmith Arthur H. Nilson  
c2 ANALYSIS OF MULTISTORY FRAMES  
WITH LIGHT GAUGE STEEL PANEL  
INFILLS

CCFSS LIBRARY Craig Jeffery Miller Robert G.  
22 1 \* 138 Sexsmith Arthur H. Nilson  
c2 ANALYSIS OF MULTISTORY FRAMES  
WITH LIGHT GAUGE STEEL PANEL  
INFILLS

DATE	ISSUED TO

Technical Library  
Center for Cold-Formed Steel Structures  
University of Missouri-Rolla  
Rolla, MO 65401

Department of Structural Engineering  
School of Civil and Environmental Engineering  
Cornell University

Report No. 349

ANALYSIS OF MULTISTORY FRAMES WITH LIGHT GAUGE  
STEEL PANEL INFILLS

A Research Project Sponsored by  
The American Iron and Steel Institute

by

Craig Jeffery Miller

Robert G. Sexsmith  
Principal Investigator

Arthur H. Nilson  
Project Director

## PREFACE

This report was originally presented as a thesis to the Faculty of the Graduate School of Cornell University in partial fulfillment of the requirements for the degree of Doctor of Philosophy, conferred in August 1972.

The author wishes to thank Professor Arthur H. Nilson, Project Director, and Professor Robert G. Sexsmith, Principal Investigator, for the help and guidance that made this work possible.

This investigation was supported by the American Iron and Steel Institute.

## TABLE OF CONTENTS

Chapter	Page
1. INTRODUCTION . . . . .	1
1.1 Statement of the Problem . . . . .	1
1.2 Drift Control . . . . .	5
1.3 Literature Review . . . . .	7
2. COMPUTER PROGRAM AND DIAPHRAGM BEHAVIOR . . . . .	17
2.1 Description of the Computer Program . . . . .	17
2.2 Light Gauge Steel Diaphragm Behavior . . . . .	25
3. PANEL BEHAVIOR . . . . .	28
3.1 Design of Panels and Details . . . . .	28
3.2 Description of the Exact Model of the Panel . . . . .	30
3.3 Description of the Approximate Model of the Panel . . . . .	35
3.4 Behavior Studies . . . . .	38
3.5 Description of the Results of Test Analyses . . . . .	41
3.6 Shear Buckling of the Infill . . . . .	46
3.7 Conclusions . . . . .	48
4. BEHAVIOR OF PLANAR MULTISTORY FRAMES WITH LIGHT GAUGE STEEL INFILL PANELS . . . . .	50
4.1 Analysis of Multistory Frames . . . . .	50
4.2 Analysis of a 26 Story Frame with Infill Panels . . . . .	51
4.3 Design for Drift Control Using Light Gauge Steel Panels . . . . .	58
4.4 Approximate Method for Choosing Panel Stiffnesses . . . . .	60
4.5 Comments and Conclusions . . . . .	64

Chapter	Page
5. SUMMARY, CONCLUSIONS AND RECOMMENDATIONS . . . . .	67
5.1 Summary . . . . .	67
5.2 Conclusions . . . . .	69
5.3 Recommendations . . . . .	71
REFERENCES . . . . .	75
APPENDICES	
A. DOCUMENTATION AND LISTING OF THE COMPUTER PROGRAM	81
B. DERIVATION OF THE ORTHOTROPIC, PLANE STRESS RECTANGULAR ELEMENT STIFFNESS MATRIX . . . . .	130
TABLES AND FIGURES . . . . .	133

## ABSTRACT

Cladding and partitions are known to have a significant effect on the behavior of structures, yet that effect is generally ignored in design. The objective of this investigation is to study the use of light gauge steel cladding and/or partitions to control drift of multistory frames. The investigation deals only with the service load behavior of an infilled multistory frame assuming linear elastic behavior of all components.

A computer program is written to analyze a general three dimensional structure including shear walls, infills and rigid or flexible floors. The equation solution routine makes use of a variation of Gaussian elimination known as wavefront processing. A documented program listing and flow charts are included.

The requirements which the connections between frame and panels must meet are determined and details proposed. An "exact" idealization of the light gauge infill which models the proposed construction as nearly as possible is developed for use in studying suitability of the infill. The light gauge steel sheets making up the panel are idealized as assemblies of orthotropic, plane stress rectangular finite elements with two degrees of freedom at each corner. The connections of sheet to sheet and sheet to frame, which are assumed to be welded, are modelled as springs whose spring constants are found experimentally.

Single story, single bay frames with different member sizes infilled with panels of different thicknesses are used to demonstrate that the reduction in drift obtained using infills is

substantial enough to justify further work.

Because the exact, or fully connected, model involves many degrees of freedom for each panel, it is necessary to develop a simpler model to make analysis of an infilled multistory frame practical. Such a model, called the corner only model because it is connected to the frame only at the corners, is developed. The errors resulting from use of the corner only model are shown to be acceptably small by comparing analyses done using both models.

Buckling of the infill panels due to in-plane shear loading is investigated using available methods to predict the buckling load. Panels of practical thicknesses and configurations are found to have sufficient buckling resistance to allow their use as infill panels.

The behavior of a 26 story frame infilled with panels of 12, 16 and 20 gauge material is examined. The 20 gauge panel reduces the deflection of the frame 40% compared to the bare frame. The 12 and 16 gauge panels, although substantially heavier, reduce drift only slightly more than the 20 gauge panels. Buckling governs the design of the 16 and 20 gauge panels in the lower stories of the structure.

An approximate method is presented which enables the designer to determine the infill stiffness required to achieve a given drift. The method gives excellent results for structures in which the deflection due to column strains is of moderate or less importance.



# CHAPTER 1

## INTRODUCTION

### 1.1 Statement of the Problem

In the design of a modern multistory structure, the contribution of cladding and interior partitions to the strength and stiffness of the structure is generally not considered, although the effect of such non-structural elements sometimes influences the choice of an allowable deflection index.\* Until recently, the methods required to analyze multistory frames including cladding and partitions as structural elements have not been available. Many practicing engineers feel that the strength and stiffness of walls as structural elements is not reliable enough for use in analysis. The likelihood that partitions will be removed in the future acts as another deterrent to their use as an integral part of the structural system.

There are important reasons for including the strength and stiffness of cladding elements in the analysis of a multistory structure. Most importantly, the supposedly non-structural members do have a significant effect on the behavior of

---

\*Deflection index is defined as the ratio of the deflection for a story divided by the height of that story or the deflection of the top story divided by the height of the entire structure.

a structure. Studies of the response of tall buildings under load support this statement. Almost invariably, measured deflections are smaller than computed deflections. In a long term study of the movement of the Empire State Building, Rathbun<sup>(1)\*</sup> showed that measured deflection is less than calculated deflection by a factor of four or five. Rathbun attributes the difference primarily to the presence of heavy stone exterior walls and masonry interior partitions. In a study of the behavior of a 56 story concrete framed apartment building, Wiss and Curth<sup>(2)</sup> obtained measured deflections of 3.3" compared to a value of 8.9" computed by the building's designer. The behavior of structures subjected to earthquake loading demonstrates the role played by cladding elements.

Another reason is the possibility of obtaining a lower cost structure. Neglecting the contribution of infills leads to a more expensive frame than necessary.

In the past decade, two developments have made possible the analyses required to include the effect of cladding on the response of a structure. The first is the emergence of matrix and finite element methods of analysis. The advent of matrix methods provided the theoretical basis for analyzing structures with large numbers of unknowns. The finite element method allows treatment of problems in continuum mechanics as an assemblage of discrete elements. The discrete element

---

\*Superscript numerals refer to the References.

representation is analyzed by matrix methods. The second development is the emergence of the digital computer.

The following quotes demonstrate that the structural engineering profession recognizes the need to improve design methods to account for the contribution of infill elements. The quotes are from a prediction of research needs for the decade 1966-1975 made by the Committee on Research of the Structural Division of the American Society of Civil Engineers<sup>(3)</sup>:

"Increased use of light-gage metal as the exterior panels of high-rise buildings has revealed gaps in our knowledge of the influence of the exterior covering of such structures. Ordinary design procedures do not consider the exterior structures as a primary structural element. Such elements do, however, contribute significantly to the lateral stiffness, damping and vibration characteristics. Openings in light-gage exterior surfaces can have a considerable effect. Contributions of the exterior covering to the properties of structures must be evaluated to develop more rational design procedures. Primary among such considerations should be the required thickness and minimum attachment for effective use of these elements as contributing structural elements."

And,

"Practically all of the past and most of the current research activity in structural engineering is concerned primarily with the behavior and design of structural elements as isolated pieces of an entire structural system. It should be recognized that the individual elements of a structure do not behave independently of those to which they are connected. Rather, the entire structure responds to the environment and the forces and motions to which the structure is subjected. Hence, greater attention must be given in the future to the behavior of the entire structural system and to the development of analytical and design procedures and concepts that take this into account."

The objective of this dissertation is to study the use of light gauge steel diaphragms as infill elements to control drift of multistory frames. A computer program is developed to analyze a general three dimensional structure including shear walls, infills and rigid or flexible floors. Single story, single bay frames of different stiffnesses and infills of different thicknesses are used to establish the suitability of the panels for reducing drift. The requirements which the connections between frame and panels must meet are determined and details proposed. An "exact" model of the light gauge infill is developed for use in studying suitability of the infill. A simpler approximate model of the panel is developed and its accuracy determined by comparing the results of analyses using it with results from analyses using the exact model. Buckling of the infill panels is investigated.

The behavior of a multistory frame with infill panels is investigated using panels of 12, 16 and 20 gauge. The efficiency and the possibility of buckling of the different panels is discussed. An approximate method suitable for hand calculation is proposed for determining the stiffness of infill required to reduce drift to a given value.

The research reported here deals only with the structural behavior of an infilled frame at service loads. The analysis and design are based on linear, elastic behavior of all components. No work is done to develop means to predict the ultimate load capacity of an infilled frame, and no statement

is possible regarding the effect of infilling on the mode of failure or on the level of the failure load.

## 1.2 Drift Control

The size of the frame members in the lower stories of a tall building is usually controlled by deflection limitations rather than stress considerations<sup>(4,5)</sup>. The problems which arise because the structure is too flexible fall into two categories; the first associated with occupant comfort, the second with integrity of finishing materials. If the building is too flexible, the cyclic deflections about a mean value which occur due to the dynamic nature of wind loading can result in excessive velocity, acceleration or jerk.\* Disconcerting groaning and creaking of the partitions and other attachments to the structure can occur if the frame is too limber. Visual perception of the motion by occupants of the building and others can also happen. Ref. 6 is an interesting account, written by a layman, of the sensations felt in a modern high-rise structure subjected to a high wind.

Current structural engineering practice is to avoid such problems by limiting the deflection index of the structure to some arbitrary value. In New York City, many structures have been designed for deflection indices of .0020 to .0030 for masonry structures and .0015 to .0025 for curtain wall struc-

---

\*Jerk is defined as the time rate of change of acceleration.

tures, based on a wind load of 20 psf above the 100' level. These structures have in general behaved well. According to Ref. 7, the following factors should be considered in choosing a deflection index:

1. type of building
2. type of occupancy
3. stiffening effects of interior and exterior walls and floors
4. shielding of the structure by nearby buildings
5. magnitude of code wind loads.

The 1970 version of the National Building Code of Canada<sup>(8)</sup> limits the deflection index to .0020 under the action of a wind load with a recurrence interval of 10 years for all buildings whose height to width ratio is four or greater. In order to avoid problems with excessive acceleration, it is generally recommended<sup>(9,10)</sup> that the maximum acceleration be limited to 0.5 to 1.5% of gravity. Ref. 9 gives an approximate expression for the maximum acceleration of a structure in the form

$$A = C(\Delta) \quad (1.1)$$

where  $\Delta$  = maximum deflection

$C$  = a factor which is a function of the natural period of the building, the gustiness of the wind, the exposure of the building and the damping ratio of the structure.

The limit on acceleration is seen to be a limit on maximum deflection of the structure. Excessive velocity would rarely be a problem in a structure and not enough is known about jerk

to make any statement about allowable limits on it. There is some evidence that increasing the stiffness of a structure increases the jerk<sup>(11)</sup>.

Damage to finishing material can be avoided by ensuring that the deflection index of any story be less than a value dependent on the characteristics of the material. Suggested values of the allowable deflection index for various materials can be found in Ref. 12.

### 1.3 Literature Review

Interest in multistory frame analysis, shear wall analysis and frame-shear wall interaction problems has increased greatly in recent years. Construction of many tall structures has increased the need for analysis methods more accurate than the portal and cantilever methods. With the advent of curtain wall structures, accurate analytical methods became more important because there were no longer large expanses of masonry to provide extra stiffness. Increased use of concrete shear walls in combination with frames served to increase interest in better analysis. At the same time, the development of matrix methods and the digital computer provided the necessary tools with which the more refined techniques could be developed. The review of advances in tall building analysis which follows is not intended to be exhaustive, but rather to point out the main trends.

The problem of analyzing a multistory building frame is a

relatively simple one. The techniques of the matrix displacement method provide the means to do the analysis. The size of the problem provides the main challenge in analyzing a tall building. In a general three dimensional structure, each joint has six possible displacements. In a tall building with a thousand or more joints, the problem is too large to work with economically for even a relatively small building.

In a series of three papers, Clough and others at the University of California made major advances in the analysis of tall buildings. In the first, Clough, King and Wilson<sup>(13)</sup> described two methods for the analysis of two dimensional frames. The girders are assumed to be inextensible, so there is one unknown horizontal displacement per floor. There are an unknown vertical displacement and an unknown rotation at each joint, so the total number of unknowns for the structure is equal to the number of stories plus twice the number of joints. Two methods of solving the resulting system of equations were presented. The first is an iterative scheme and the second is a recursive technique based on the tridiagonal nature of the stiffness matrix.

A second paper by the same authors<sup>(14)</sup> extended the usefulness of the tridiagonalization scheme proposed in the first paper. Symmetrical three dimensional frames can be dealt with if the loading is symmetrical and the floor system can be assumed rigid in its own plane so that all frames deflect the same amount. The stiffness matrix for each frame is formed



story by story. The recursion relation developed previously is used to eliminate the vertical and rotational unknowns, leaving a reduced stiffness matrix involving one unknown horizontal displacement per floor. The lateral stiffnesses for all floors are added together and the horizontal displacements solved for. The effects of axial deformation of the columns and shear deformations of all members are accounted for. Shear walls can be included by treating them as columns of finite width.

In the third paper, Clough and King<sup>(15)</sup> extended the method to treat an unsymmetrical three dimensional building. The floor system is assumed rigid, so that three displacements are sufficient to describe the motion of all points on a floor. Axial deformations of columns and beams are neglected. These two assumptions mean the behavior of frames in perpendicular directions is uncoupled. The lateral stiffness matrices for all frames are formed and summed to form the structure stiffness matrix. The structure stiffness matrix is solved for the floor displacements. The method is of limited use because of the neglect of axial deformations.

Weaver and Nelson<sup>(16)</sup> developed a method of analysis that treats an unsymmetrical multistory frame without restrictive assumptions. They assume the frame is laid out in a rectangular pattern and that the floor system is sufficiently rigid that in-plane deformations are negligible. Their analysis includes torsion of all members. The structure stiffness

matrix in tridiagonal form is generated story by story and the unknowns solved for using recursion relations. Results are presented for an ell-shaped 20 story structure showing the influence of axial and torsional deformations on behavior. Structures with diagonal bracing and/or shear walls cannot be analyzed.

The methods outlined above are special purpose tools for analysis of multistory frames. Much effort has been expended to develop very general computer programs. Two examples are STRUDL II<sup>(17,18)</sup> and NASTRAN<sup>(19)</sup>. STRUDL II is capable of analyzing multistory frames including finite member widths, irregular frame configurations, shear deformations and other effects. It is equipped to do finite element analysis. STRUDL II must deal with all six degrees of freedom at a joint in a three dimensional problem. The saving in effort possible due to rigidity of the floors is lost. NASTRAN is a similar program which is not as widely used.

There are three approaches to the analysis of shear walls, which are defined as shear resisting elements without surrounding frame members. The first is to treat the wall as a free standing cantilever beam. This method is suitable for tall slender walls with relatively few openings and for tall walls coupled by slender lintel beams<sup>(20)</sup>.

The second approach is the continuous connection technique, examples of which can be found in papers by Coull, Rosman and others<sup>(21-24)</sup>. The basic assumptions are that each

wall in the coupled system deflects the same amount and that there is a point of inflection at midspan of each lintel beam. The lintels are replaced by a continuous medium with the same stiffness. By considering compatibility of displacements, a second order differential equation is obtained. The major advantages of this method are its simplicity and the fact that it leads to a closed form solution. The method is limited to structures that are fairly regular with few changes in stiffness of the walls and lintel beams.

The last approach is to model the wall as an assemblage of finite elements. The major advantage of the finite element technique is its versatility. Any geometry, any distribution of material properties and any loading pattern can be dealt with. The disadvantage is that a fine mesh with many degrees of freedom is necessary for accurate results.

Girijavallabhan<sup>(25)</sup> modelled a coupled wall system as an assembly of either linear strain triangles or plane stress rectangles. He modelled the lintel beams with the same elements, which is questionable if the lintels are slender.

McLeod<sup>(26)</sup> developed a rectangular plane stress element with a rotational degree of freedom at each corner node. He used  $\frac{\partial v}{\partial x}$  and  $-\frac{\partial u}{\partial y}$  where  $u$  is the horizontal displacement and  $v$  the vertical displacement, alternately from corner to corner as the rotational degree of freedom. In this way, lintel beams can be modelled as beam elements. This scheme requires two types of elements in order to have a unique rotation at a

corner and results in an unsymmetrical problem even though the geometry of the structure is symmetrical. McLeod presented results which show close agreement with analyses considering the shear walls as wide columns, when the lintels are slender. If the lintels are deep, the results compare well with those using plane stress elements.

Weaver and Oakberg<sup>(27)</sup> made use of three different elements to analyze a frame-shear wall system. Elements in the interior of the wall have two freedoms per node, elements along the edges have three per node and elements which connect interior and exterior elements have a total of ten degrees of freedom, two nodes with three each and two with two each. The freedoms are a horizontal and vertical displacement at all nodes and a rotation at the nodes with three freedoms. The deformations at the intersections of beams and walls can be modelled properly. Special provisions are included to handle the case of lintel beams which are deep compared to the story height. As a result of example analyses presented, the authors concluded that the wide column frame approach is adequate for slender walls of regular configuration. For squat walls and walls of irregular shape, they concluded the finite element technique is best.

One of the first attempts to solve the problem of frame-shear wall interaction was made by Khan and Sbarounis<sup>(28)</sup>. They presented a method which is approximate and iterative. It is applicable to symmetrical three dimensional structures.

Weaver, Brandow and Manning<sup>(29)</sup> extended the method of Ref. 16 to the analysis of a structure with frames and shear walls, diagonal bracing and setbacks. The shear walls, which need not be planar, are modelled as beam elements including uniform and non-uniform torsion. To include warping torsion, the rate of twist of the section becomes a degree of freedom. The floor is assumed rigid. The result is a very general solution to the frame-shear wall interaction problem.

Another approach to the same problem is to combine a matrix displacement frame analysis with analysis of the shear wall by finite elements. Ref. 26 and 27 are examples of this approach. Programs such as STRUDL II and NASTRAN are well suited to this type of analysis.

The little published work concerned with the analysis of multistory infilled frames attempts to predict the lateral stiffness of frames infilled with masonry or concrete, in which no tension can exist between frame and infill. An infill is a shear resisting element surrounded by framing members. Ref. 30 is a comprehensive bibliography of research up to 1968. The work has concentrated on finding empirically the area of an equivalent diagonal to substitute for the infill. The area is a function of frame stiffness, length of contact between infill and frame, thickness of infill and modulus of infill. The research of Stafford-Smith<sup>(31,32)</sup> is typical of work in this area.

There are two papers which attempt to solve the infill-

frame interaction problem using finite elements. Karamanski<sup>(33)</sup> used rectangular plane stress elements. His solution is doubtful because he assumed that frame and infill remain in contact everywhere and frame members are completely flexible perpendicular to their length. The first is true only at very small loads and the second is not correct for frames of realistic proportions.

A more realistic approach was taken by Mallick and Severn<sup>(34)</sup>. They used a rectangular plate stretching element derived on the basis of Pian's complementary energy approach<sup>(35)</sup>. The analysis is carried out in two phases, each iterative. The first establishes the length of contact between frame and infill, while the second includes the effects of slip between the frame and the infill. The first step is an analysis assuming the frame and the infill displace the same perpendicular to the frame, but are free to displace differently parallel to the frame. Wherever tension is indicated between frame and infill, displacement continuity is relaxed and the analysis repeated until the contact length remains the same for two successive cycles. Slip between the frame and infill is accounted for by introducing shear forces equal to the coefficient of friction times the normal force over the contact length. Iterative analyses are done until the assumed shear force is correct. Mallick and Severn's analysis is the most rational attempt to solve the problem, but it is prohibitively expensive to use to analyze a multistory frame.

Little has been done to study the interaction of light gauge infills with multistory frames. A substantial amount of research has been done to determine the shear stiffness of light gauge diaphragms. McGuire<sup>(36)</sup> presented a summary of work in this area to 1967. Nilson<sup>(37)</sup> tested a large number of full scale diaphragms in cantilever and beam type apparatus. The diaphragms were constructed of 16, 18, and 20 gauge material of varying configuration with different spacings and sizes of fasteners. His results indicate that the stiffness of the panel decreases as its span increases.

Luttrell<sup>(38)</sup> also tested a large number of diaphragms. The variables included panel configuration, fastener type and spacing, material properties and span lengths. He investigated the influence of marginal frame stiffness and repeated loading on the strength and stiffness of diaphragms. His results indicate that the stiffness of a diaphragm is primarily dependent on panel length, panel shape and spacing of end fasteners. He proposed a semi-empirical formula for the shear stiffness of a diaphragm, and presented a method for analyzing a portal structure including the effect of diaphragm behavior.

Bryan and others at the University of Manchester<sup>(39-43)</sup> have done much research to develop ways to use the shear stiffness of corrugated sheeting to reduce the size of frame members in portal sheds. They presented analytical methods for determining shear stiffness. Many others have made contributions, including Pincus, Errera, Fisher and Apparao<sup>(44-50)</sup>.

Ammar<sup>(51)</sup> has attempted to predict the shear stiffness of a diaphragm analytically. His work is described in the second part of Ch. 2.



## CHAPTER 2

### COMPUTER PROGRAM AND DIAPHRAGM BEHAVIOR

#### 2.1 Description of the Computer Program

In order to study the use of light gauge steel infill panels for drift control in a multistory frame, a computer program to analyze the infilled frame must be available. The analysis package should be capable of dealing with 10000 or more degrees of freedom. For maximum flexibility and economy, the analyst should be able to choose between an analysis considering the floors rigid in their own plane and one accounting for the flexibility of the floors. The program should treat infills and shear walls. Analysis of structures with setbacks, overhangs, transfer girders, omitted girders and diagonal bracing should be possible.

A survey of the literature revealed no program providing precisely the capabilities desired. The only analysis package that meets most of the requirements is STRUDL II<sup>(17,18)</sup>. STRUDL II is unable to treat the floor system as a rigid lamina. This is an important shortcoming since it means a three dimensional analysis involves six degrees of freedom per joint, rather than three per joint plus an additional three per floor. STRUDL II is written for IBM 360 series machines but for this work a program which could be used on many machines is

desirable. Because no available program is satisfactory, a program was written to provide the needed capabilities.

Three basic assumptions were made at the outset. First, the program will analyze only linear, elastic structures. The program will be used to analyze infilled frames at service loads, where the behavior of members and components is generally assumed elastic. The effect of connector non-linearity is examined in Ch. 3. Secondly, simple bending theory, neglecting effects of axial force on flexural stiffness, is used to develop stiffness matrices for flexural members. Thirdly, small deflection theory is used; equilibrium equations are based on the undeformed geometry; i.e., the P- $\Delta$  effect is neglected. Neglecting these effects is common practice in working load analysis. Since the displacements of the clad frame are smaller than for the unclad frame, the result of neglecting these effects should be smaller than in the unclad frame.

The most important part of an analysis package is the equation solution routine. After a survey of methods, a wavefront routine programmed by Bruce Irons<sup>(52)</sup> was chosen. The capacity of the routine is limited only by the storage required for the wavefront, which is generally small. Auxiliary storage is used extensively by the program, which deals efficiently with elements with many degrees of freedom, not all located at the corners. Since it was anticipated that infills could be represented by such elements, the wavefront routine was a

logical choice. Irons' routine is versatile, making addition of new elements and new features simple.

The wavefront technique is a variation of Gaussian elimination. Using Gaussian elimination, the element stiffness matrices are assembled into a structure stiffness matrix, support conditions applied and the elimination carried out. The frontal solution alternates between assembling element stiffness matrices and eliminating those variables that do not appear in the remaining elements. The master stiffness matrix is never formed. The back substitution process is the same for either method.

The differences between Gaussian elimination and wavefront processing can be seen most easily by following the analysis of the simple cantilever of Fig. 2.1. The element stiffness matrices are

$$k^e = \frac{AE}{L} \begin{bmatrix} 1 & -1 \\ -1 & 1 \end{bmatrix} \quad (2.1)$$

Assembling the element  $k$ 's yields the master stiffness matrix

$$k = \frac{AE}{L} \begin{array}{c} \begin{array}{cccc} & u_1 & u_2 & u_3 & u_4 \\ \begin{bmatrix} 1 & -1 & 0 & 0 \\ -1 & 2 & -1 & 0 \\ 0 & -1 & 2 & -1 \\ 0 & 0 & -1 & 1 \end{bmatrix} & & & & \end{array} \end{array} \quad (2.2)$$

Applying the support conditions results in the reduced stiff-

ness matrix

$$k = \frac{AE}{L} \begin{bmatrix} 2 & -1 & 0 \\ -1 & 2 & -1 \\ 0 & -1 & 1 \end{bmatrix} \quad (2.3)$$

The final equation system is

$$\frac{AE}{L} \begin{bmatrix} 2 & -1 & 0 \\ -1 & 2 & -1 \\ 0 & -1 & 0 \end{bmatrix} \begin{Bmatrix} u_2 \\ u_3 \\ u_4 \end{Bmatrix} = \begin{Bmatrix} 0 \\ 0 \\ P \end{Bmatrix} \quad (2.4)$$

Performing the Gaussian elimination results in

$$\frac{AE}{L} \begin{bmatrix} 2 & -1 & 0 \\ 0 & 3/2 & -1 \\ 0 & 0 & 1/3 \end{bmatrix} \begin{Bmatrix} u_2 \\ u_3 \\ u_4 \end{Bmatrix} = \begin{Bmatrix} 0 \\ 0 \\ P \end{Bmatrix} \quad (2.5)$$

Starting at the bottom of the matrix and working to the top completes the analysis and gives the displacements

$$u_4 = \frac{3PL}{AE} \quad u_3 = \frac{2PL}{AE} \quad u_2 = \frac{PL}{AE} \quad (2.6)$$

Using wavefront processing, elements one and two would be assembled to give

$$\frac{AE}{L} = \begin{bmatrix} 2 & -1 \\ -1 & 1 \end{bmatrix} \begin{Bmatrix} u_2 \\ u_3 \end{Bmatrix} = \begin{Bmatrix} 0 \\ 0 \end{Bmatrix} \quad (2.7)$$

Since displacement  $u_2$  does not appear in any of the remaining

elements, it can be eliminated, to give

$$\frac{AE}{L} \begin{bmatrix} 2 & -1 \\ 0 & 1/2 \end{bmatrix} \begin{Bmatrix} u_2 \\ u_3 \end{Bmatrix} = \begin{Bmatrix} 0 \\ 0 \end{Bmatrix} \quad (2.8)$$

Next, element three is added to the solution, yielding

$$\frac{AE}{L} \begin{bmatrix} 2 & -1 & 0 \\ 0 & 3/2 & -1 \\ 0 & -1 & 1 \end{bmatrix} \begin{Bmatrix} u_2 \\ u_3 \\ u_4 \end{Bmatrix} = \begin{Bmatrix} 0 \\ 0 \\ P \end{Bmatrix} \quad (2.9)$$

Carrying out the eliminations for  $u_3$  and  $u_4$  yields Equation

2.5. Back substitution yields the same displacements as

before.

The results are the same, although the order of operations is different. The advantages of the wavefront technique are:

1. A smaller area of computer core is required, because only stiffness coefficients and load components associated with variables in the wavefront need to be in core.
2. The numbering system used for the degrees of freedom is immaterial. In band algorithms the numbering scheme is crucial to efficiency. The order of presentation of elements determines the efficiency of wavefront solutions. Elements should be presented to minimize the wavefront.
3. Because the bandwidth does not determine efficiency, changes to the numbering system can be made simply. With a band algorithm a change in the structure can require complete renumbering to achieve minimum bandwidth.
4. The algorithm is especially well suited to use with elements having many degrees of freedom associated with nodes not at the corners of the element.

The disadvantages of the wavefront method include:

1. The coding required is more complicated than required for Gaussian elimination because of the bookkeeping needed to keep track of variables in the wavefront.
2. The master stiffness matrix is never assembled, so it is not available to aid in checking. This is particularly a problem when trying to debug changes.

The coded wavefront routine presented by Irons has been used in the analysis program without major changes. The only significant addition to Iron's work is a routine which assembles element stiffness matrices to form a subassembly stiffness matrix which is used as an element stiffness matrix in Irons' routine. The subassembly routine was added to make more efficient use of auxiliary storage, resulting in substantial savings in computer time. In Appendix A, which is a listing of the program, this routine is called STIGEN.

The program contains a beam element with six degrees of freedom, a column element with ten degrees of freedom and an orthotropic plane stress rectangle with eight degrees of freedom. In Appendix A, the beam element stiffness matrix is generated in subroutine BEAM, the column stiffness matrix in subroutine COLUM and the plane stress stiffness matrix in subroutine PLATE. Additional elements can be added with little programming beyond that required to generate the element stiffness matrix.

Output consists of displacements, reactions and forces and moments at the nodes of the elements. The element forces and moments are calculated by multiplying the element stiffness matrix by the appropriate displacements. Degrees of freedom

associated with the reactions are not eliminated from the stiffness matrix. Instead,  $10^{20}$  is added to the diagonal term associated with the supported degrees of freedom. Solution of the equations yields for those degrees of freedom a displacement equal to the reaction times  $-10^{-20}$ .

The program analyzes large structures efficiently. The largest problem solved had about 2300 degrees of freedom. The time required to solve the problem was  $8\frac{1}{2}$  min. on the 360/65 computer. A three dimensional multistory structure with 660 unknowns required  $2\frac{1}{2}$  minutes. The 1928 degree of freedom panel discussed in Ch. 3 took  $6\frac{1}{2}$  minutes. Although comparison is difficult because of differences in machines, programmers and problems, these times seem to compare well with those quoted by Cantin<sup>(53)</sup>.

The program satisfies the basic requirements set forth at the beginning of this chapter. However, there are some limitations on the type of shear wall structure that can be analyzed. To get accurate results from an analysis considering shear walls as wide columns, it is necessary to modify the lintel beam stiffness to account for the finite width of the shear wall. The programming necessary is not difficult but has not been done.

The program does not contain a plane stress element with rotational degrees of freedom to provide interelement compatibility between shear wall elements and beams framing into them. Such an element is presented by Weaver and Oakberg<sup>(27)</sup>. No

means of treating shear walls in the shape of channels or zees is available.

The analysis is done without restrictive assumptions. Horizontal, vertical and rotational degrees of freedom are taken into account. If desired, shear deformations of all members can be included. The structure can be analyzed for multiple load cases. Internal hinges and prescribed zero force components can be accommodated. The facility which assembles elements into a subassembly permits a reduction in the amount of input data required for structures with similar subassemblies.

The program analyzes only structures whose members are parallel to one of three perpendicular planes, although the transformations necessary to permit analysis of a general shaped structure could be added easily. The torsional stiffness and weak axis bending stiffness of the floor members is neglected. The torsional stiffness of the columns is considered infinite.

The program is not organized to reanalyze a structure which has been slightly modified, nor is there a way to analyze a structure with prescribed displacements.

The program can be easily modified to include in the analysis the effect of axial force on flexural stiffness and the P- $\Delta$  effect. Analysis including these effects requires iterations. Because the back substitution involves a back-space-read-backspace sequence in the computer, the iterations



requires are quite costly.

Appendix A contains a documented listing and flow charts of the program. The program is written in Fortran IV which contains extensions to the provisions of ANSI standard X 3.10. The programs requires 302,000 bytes of core storage on the 360/65. All calculations are done in double precision arithmetic. Attempts to use single precision indicate that round-off error is too large for problems of 500 degrees of freedom and larger.

## 2.2 Light Gauge Steel Diaphragm Behavior

A light gauge steel diaphragm is a two dimensional surface structure constructed of four kinds of components. These are light gauge panels, end and edge fasteners, sheet to sheet fasteners and a frame which surrounds the diaphragm. Fig. 2.2 shows a typical diaphragm with the various components indicated. The purpose of the marginal frame is to transfer axial loads. End fasteners attach panels to the frame at the ends of the corrugations. The edge of the panels parallel to the corrugations is attached to the frame by the edge fasteners. The sheet to sheet fasteners transfer force from one sheet to the next. The fasteners can be screws, welds, or in the case of sheet to sheet fasteners, mechanical crimps in the panels. Typical welded fasteners are indicated in Fig. 2.3.

Light gauge diaphragms are used to resist transverse loads and in-plane shear loads. An example of a diaphragm

resisting transverse loading is a metal deck roof. Another is a floor constructed of metal deck with a concrete topping. Quite often that floor system is also required to transfer wind shears. Light gauge panels used as infills are also examples of shear resisting membranes.

Shear stiffness is the most important property of diaphragms for performance under in-plane shear loads. Referring to Fig. 2.4, shear stiffness is a measure of the deflection  $\Delta$  at the corner produced by a load  $P$ . Because of the complexity of diaphragms, their shear stiffness could be determined only experimentally until recently. The papers on light gauge panel behavior cited in Ch. 1 deal with experimental investigations of diaphragm behavior. The experimental approach has two major disadvantages:

1. It is expensive and time consuming because a large scale test must be done.
2. A new test is required whenever a major change in any parameter is made.

The work of Ammar<sup>(51)</sup> is an attempt to reduce the amount and scale of experimentation required to predict diaphragm behavior. The diaphragm is treated as an assembly of its individual components, whose stiffness can be found experimentally. Using component stiffness matrices, the diaphragm can be analyzed using matrix methods.

The diaphragm model is composed of rectangular orthotropic plane stress elements to model the sheets, linear elastic springs to model the connections and beam elements to model

the frame. The stiffness of the fasteners, the shear stiffness of the corrugated sheet and the elastic modulus of the sheet in the weak direction are found experimentally.

Ammar analyzes two diaphragms for which experimental results are available. As shown in Table 2.1, the analytical results are in reasonable agreement with the experimental values. He concludes that the basic approach is sound and the prediction of diaphragm behavior analytically is now possible. The main aim of future research should be to find better methods to measure the shear modulus of the light gauge material. Ammar's results indicate that the discrepancy between the analytically derived shear stiffness of the diaphragm and the value obtained experimentally is traceable to uncertainty in the shear modulus.

## CHAPTER 3

### PANEL BEHAVIOR

#### 3.1 Design of Panels and Details

There are three basic structural requirements the panels must satisfy to be useful to control drift. The first is high resistance to in-plane shear loads. The obvious choice is a panel with a continuous plane of material in the plane of the loading. The cellular profile deck (Fig. 3.1a) can be treated as a flat sheet with the cells serving as stiffeners. On practical grounds however the cellular deck is not a good choice for infills, since it is more expensive to manufacture than open deck because two pieces of material must be joined and more expensive to ship because it cannot be nested.

An open profile (Fig. 3.1b) has neither of these disadvantages, but for the open section to resist shear loadings effectively, distortion of the profile at the ends of the diaphragm must be prevented, by firmly fastening the panel to the frame. The present research deals only with panels of open, trapezoidal profile. To fully utilize the panel stiffness, it is assumed fastened to the supporting members at every flat.

The second structural requirement is ability to carry transverse loads. Exterior wall panels must transmit wind load to the frame. An interior panel must resist 10 to 20 psf.

The panels studied here are of minimum 20 gauge thickness and  $1\frac{1}{2}$ " depth. For the ten to twelve foot spans used here, 20 psf capacity is reasonable.

The third requirement is possession of sufficient buckling resistance. Buckling can occur due to two types of loading. The first is uniform shear loading. Resistance to shear buckling must be provided by the sheet. Buckling can also occur due to direct in-plane loads from the girders bounding the infill. Using suitable connection details, in-plane load transferred from girders to panels is minimized, eliminating this type of buckling. Gravity loads are transferred from the girders to the columns and thence to the foundations, rather than through the infills to the foundations. Excessive stress and deformation of the panel to frame connections caused by deflection of the girders is also avoided with such details.

The connection details chosen to connect the panel to the frame must transmit lateral loads from the frame member to the panel. The type of construction envisioned to accomplish this is shown in Fig. 3.2a. The frame member is connected to the infill by a light gauge steel channel fastened to the frame member either continuously or at closely spaced intervals. The channel is sized so the trapezoidal panels can be slipped between the flanges of the channel. The panels are welded to the toes of the flanges. Fig. 3.2b shows the panel connected to the channel member on both sides, forming a nearly continuous connection. The continuous connection prevents distortion

of the deck profile at the ends. A substantial reduction in stiffness occurs if the panel can distort.

All connections dealt with in this research are welded. Use of welded connections results in a more rigid diaphragm than is possible with mechanical fasteners. The behavior of the structure will be more nearly linear with welded connections than it would be if other types of connectors were used. The connections around the perimeter of the panel are assumed to be fillet, plug or puddle welds. Since the panels are used in a vertical position, welding can be done from either side of the sheet, in contrast to floor diaphragms, where welding must be done from above. Because of this, it is possible to use the welds shown in Fig. 2.3c for the seam connections. This type of weld is stronger and stiffer than the type shown in Fig. 2.3d, which is a standard floor diaphragm seam weld.

The panel to frame connection minimizes transfer of vertical load from frame members to the panel. Figs. 3.2b and 3.2c show possible details to accomplish this. In Fig. 3.2b, load transfer is reduced by including in the marginal member an inclined portion which flexes as the girder is loaded. In Fig. 3.2c, transfer is prevented by one channel sliding within another. These details are only suggestions. Experimental work is required to develop the best details.

### 3.2 Description of the Fully Connected Model of the Panel

The model of the panel described in this section is referred to as fully connected because the marginal member is

connected to the frame continuously. In section 3.3, a less exact model of the panel connected to the frame only at the corners is described. Fig. 3.3a shows the idealization of an infilled frame. The basic approach to the idealization will follow that taken by Ammar<sup>(51)</sup>. The connectors are modelled as linear, elastic springs whose spring constants are obtained from tests. The design load for the connections is about 65% of the ultimate load,  $P_U$ . Connection tests by Ammar<sup>(51)</sup>, two of which are plotted in Fig. 3.4, indicate that welded seam connections behave linearly to about  $.55P_U$  and at  $.65P_U$ , the stiffness is 80% of the initial. The weld tested is similar to that shown in Fig. 2.3c. Only a small number of the connections will reach  $.65P_U$  at working loads, thus many will be at loads in the linear range. Commercial tests of large, welded diaphragms at Cornell indicate linear behavior of the system to at least 60% of the ultimate load. Results are presented later in this chapter to show that use of the initial stiffness results in small error.

Both the marginal member and the frame member are idealized by linear, elastic beam elements derived from cubic displacement functions. This element has three degrees of freedom at each end; horizontal displacement, vertical displacement and rotation. The sheets used to form the infill panel are modelled as an assemblage of orthotropic plane stress finite elements. The plane stress element chosen is rectangular with a horizontal and vertical degree of freedom at each corner.

The derivation of the element stiffness matrix is outlined in Appendix B and given in complete detail by Maghsood<sup>(54)</sup>.

The simple 8 degree of freedom rectangle was chosen instead of a more refined element such as presented by Weaver and Oakberg<sup>(27)</sup> because the resulting model gives a better representation of the panel behavior. An element with rotational degrees of freedom would force compatibility between the frame members and the infill, but the physical behavior of the panel allows it and the frame to displace different amounts vertically. The transfer of shear between the frame and the infill should be uniform, but the element of Ref. 27 cannot properly represent that because it forces a parabolic variation of edge shear, with a zero value at the corners.

Fig. 3.3b shows the degrees of freedom assumed at the edge of the panel. The marginal channel and the frame member deflect the same amount vertically and rotate the same amount. The vertical displacements can have different values. The difference represents the deformation of the flexible link between frame and marginal member. Fig. 3.3b also indicates that the displacements of the sheet at its junction with the edge member need not be the same as those of the edge member. The difference is the deformation of the connection. Fig. 3.3c shows the degrees of freedom at a sheet to sheet connection. For the analysis, the continuous connectors which join sheet to marginal member and marginal member to frame are lumped at the nodes of the finite elements.



Four independent material properties are necessary to specify the behavior of an orthotropic plate subject to in-plane loads. There are five material constants for an orthotropic material whose principal axes coincide with the axes of orthotropy;  $E_x$ ,  $E_y$ ,  $\nu_{yx}$ ,  $\nu_{xy}$ , and  $G_{xy}$ . Only four are independent because  $E_x \nu_{yx} = E_y \nu_{xy}$ . Referring to Fig. 3.5 for the directions of the coordinate axes and the direction of the corrugations, the elastic modulus of an equivalent flat sheet parallel to the corrugations is  $E_y = E(\ell/s)$  where  $E$  is the elastic modulus of the base material,  $\ell$  is the developed width and  $s$  the flat width of the sheet. The elastic modulus perpendicular to the corrugations,  $E_x$ , is found experimentally. The experimental value can be confirmed roughly by an energy analysis of one corrugation. For small deflections,  $E_x$  is on the order of 500 ksi<sup>(51)</sup>. This is because it takes little load to unfold the corrugations. For shear loads, the calculated displacement of a diaphragm is not sensitive to the value of  $E_x$ . The value  $\nu_{yx}$  is equal to Poissons ratio for the base material. The value of  $\nu_{xy}$  is found from the other constants.

The value of the shear modulus,  $G_{xy}$ , is equal to  $G(s/\ell)$  where  $G$  is the shear modulus of the base material. The shear modulus of the equivalent flat plate is dependent on the conditions of restraint at the ends of the panel. If warping of the ends of the sheet is prevented, the above expression for the shear modulus is nearly true. It is not precisely true

because the webs of the trapezoidal section are not restrained. If the ends of the panel can distort, the shear stiffness of the diaphragm is greatly reduced. The work of Ammar<sup>(51)</sup> indicates that  $G_{xy}$  for panels fastened at every second or third valley is approximately an order of magnitude lower than results from  $G(s/l)$ .

To determine the coarsest mesh that will give acceptable accuracy, the single bay, single story frame described in section 3.4 was analyzed using three different grids. The dimensions of the trapezoidal sheets in the structure are 2'-6" by 12'-0". First, each sheet was divided into six elements  $2\frac{1}{2}$  feet by 2 feet. The next level of refinement divided each sheet into 24 elements. The final refinement used 54 elements per sheet. The convergence curve plotted from the results is shown in Fig. 3.6. The coarsest grid gives displacements about 30% less than the finest mesh. The asymptote to the convergence curve is derived using Richardson's three point extrapolation for an approximation with error term of order  $(h^2)$ .

For the analyses described in the balance of this chapter, the coarse grid is used. These are done to assess the suitability of light gauge panels as drift control elements and to assess the accuracy of the approximate model described in section 3.3. The displacements for either the coarse grid or the fine grid compared with the displacement of the unclad frame indicate that the mesh refinement error will not affect the decision on panel suitability. The approximate model and

the fully connected model are analyzed using the finest mesh and the coarse mesh for one combination of panel and frame. The percentage error in the approximate analysis is about the same, regardless of mesh size, indicating that the coarse mesh yields acceptable comparisons. The work described in the next chapter on multistory frames uses the finer grid to derive panel stiffnesses.

### 3.3 Description of the Corner Only Model of the Panel

Because of the large number of degrees of freedom involved in the fully connected model of an infilled frame, an approximate model, called the corner only model, is necessary for multistory analysis to be practical. The degrees of freedom in the interior of the panel could be eliminated using static condensation, but the problem would still involve far more unknowns than the bare frame. The ideal situation would be to have a substitute panel which would closely approximate the behavior of the actual panel although connected to the frame only at the corners. The analysis of the frame could then be done with no increase in size compared to the analysis of the bare frame. With such an approximate model, the derivation of the stiffness matrix for the infill needs to be done only once for each type of infill.

As a beginning in the search for such a model, the panel idealization described in the last section is used, except that the marginal member is separated from the frame everywhere

except at the corners, as shown in Fig. 3.7. An analysis of this model yields horizontal corner displacements about double the correct ones. Examination of the displacements makes it clear that the cause of the differences is folding of the profile on the windward side and opening up of the profile on the leeward side. The relative displacements in the horizontal direction between the corners is the same for the fully connected and corner only models, although the pattern of the displacements is entirely different. Because of the flexible edge member in the corner only model, transfer of load from the frame to the diaphragm cannot take place in the proper manner. In the fully connected model, the diaphragm is loaded with uniform shear loading, causing uniform compression of the panel edges and a uniform distribution of displacement from corner to corner. The light member in the corner only model is not stiff enough axially to force this behavior. Most of the load is transferred to the sheet near the point of application of the load. The panel is highly compressed near the load, causing the profile to fold up.

The above discussion suggests the possibility of obtaining better agreement between the two models by providing a greater area to the marginal members in the corner only model. Sufficiently stiff edge members will cause uniform transfer of shear from the perimeter member to the sheet. The analysis was rerun with the area of the marginal member set to its area plus the area of the frame member. The area of the frame

members was set to zero. The results of this analysis showed excellent agreement with the results of the fully connected model analysis. If only the area of the horizontal members is modified, the two models agree within three percent. If the areas of all members are modified, the results agree within one percent. The results are presented and discussed in detail in section 3.5 describing results of the behavior studies.

Referring to Fig. 3.8, all of the nodes within the dotted lines are not connected to the frame. Because of this, the degrees of freedom associated with them can be eliminated by static condensation<sup>(55)</sup>, or by forming the flexibility matrix for the corner degrees of freedom only and transforming it to the stiffness matrix. The equations for the static condensation are

$$\begin{Bmatrix} P \\ \text{---} \\ 0 \end{Bmatrix} = \begin{bmatrix} K_{ss} & | & K_{sf} \\ \text{---} & | & \text{---} \\ K_{fs} & | & K_{ff} \end{bmatrix} \begin{Bmatrix} u_s \\ \text{---} \\ u_f \end{Bmatrix} \quad (3.1)$$

where  $P$  = loads at nodes connected to other parts of the structure,

$u_s$  = displacements at nodes connected to other parts of the structure,

$u_f$  = displacements at nodes not connected to other parts of the structure,

$K$ 's are submatrices of the stiffness matrix.

In this equation, the matrices are partitioned into two segments, one pertaining to those degrees of freedom which have no loads and those which are loaded or connected to other

parts of the structure. The condensation is accomplished by solving the lower partition for the displacements at the free nodes and substituting the result into the upper partition.

The matrix manipulations required are

$$\{u_f\} = -[K_{ff}]^{-1}[K_{fs}]\{u_s\} \quad (3.2)$$

$$\{P\} = [K_{ss}]\{u_s\} - [K_{sf}][K_{ff}]^{-1}[K_{fs}]\{u_s\} \quad (3.3)$$

or 
$$\{P\} = [K^*]\{u_s\} \quad (3.4)$$

where 
$$[K^*] = [K_{ss}] - [K_{sf}][K_{ff}]^{-1}[K_{fs}] . \quad (3.5)$$

In this research, the panel stiffness matrix was derived by forming the flexibility matrix of the panel and then transforming it into the stiffness matrix.

### 3.4 Behavior Studies

The preceding sections describe the idealizations used to study the behavior of the panel-frame combination. In this section the test problems devised to study panel behavior are described and the objectives of the analytical program discussed. The most important objective is to determine if the use of light gauge steel trapezoidal panels to control drift is effective.

The second objective is to determine if the strength of the panels is sufficient. It is possible that the panel is stiff enough compared to the frame to attract enough horizontal load to cause failure of the panel. Similarly, the panel

may attract more load than the panel to frame connections can resist. Finally, the panels may prove so stiff in relation to the frame that they will carry almost all of the lateral load. The frame would not participate until the panels failed, which is undesirable.

The third goal is to assess the accuracy of the corner only model in a variety of infilled frames. If it yields accurate results over a broad range of the parameters of importance in multistory buildings, then the model is useful in the design of high-rise structures with trapezoidal panels.

The fourth objective is to investigate the likelihood of shear buckling of the infill. If shear buckling occurs at a load substantially below the allowable load on the panel, the panels are not suited to drift control. If the buckling load is sufficiently high, a simple design rule to avoid buckling is sought.

The investigations described in this section are done using the structures in Fig. 3.9. These simulate an interior panel of a multistory, multibay frame. The frames are thirty feet wide and twelve feet high. The dimensions and member sizes are intended to be representative of those found in a modern office structure between twenty and forty stories high. Two thicknesses of panel material are used in the analytical tests, 16 and 20 gauge. Load cases studied are lateral load applied as a concentrated load at the upper corner of the frame and gravity loads applied uniformly on the upper and

lower girders with concentrated loads of 995.4 k at the upper corners to simulate load from the columns above. The uniform loads used are:

dead load: 1.5 kips/foot

live load: 2.25 kips/foot

The assumption is made that gravity loads are applied to the frame after the panels are installed.

The value of the spring constant for the seam connections is taken from the work of Ammar<sup>(51)</sup>. His results indicate that the stiffness parallel to the seam is 500 kips/in. Perpendicular to the seam, diaphragm tests show little movement between the two sheets. For this reason, the spring constant for this direction is taken as 10000 kips/in. These values have been used for all sheet thicknesses, since Ammar's results indicate that at low load levels ( $\leq 40\%$  of ultimate) the stiffness is nearly independent of sheet thickness. The stiffnesses are equal to the secant modulus at 40% of the ultimate connection load.

The spring constants for the end and edge connectors are taken as 2000 kips/in. and 1000 kips/in. respectively. These values are based on results presented in Ref. 56. The influence of the value chosen for these spring constants will be investigated by varying them while holding all other parameters constant.



### 3.5 Description of the Results of Test Analyses

Table 3.1 summarizes the results of nine analyses of the frames described above. All analyses were performed using the same value of horizontal load on the frame and using the fully connected model for the infills. The addition of the light gauge diaphragm substantially reduces the deflection. The column labelled "Horiz. Deflection" gives the values from the analyses. The fourth column gives an estimate of the results obtained if a fine mesh were used. This value is obtained by multiplying all the values in the third column by the ratio  $.204/.140$ . That is the ratio of the "correct" displacement obtained by extrapolation to the displacement from the coarse grid analysis. Table 3.1 is evidence that the reduction in drift is large enough to indicate that light gauge infills may be practical for drift control. The drift of the frame infilled with a 16 gauge panel is only 20% less than that for the frame with 20 gauge panel, although the 16 gauge panel contains 40% more material. This happens because the seam connection stiffness is the same in either case. Thus, it is apparently advantageous to use lighter panels, if buckling is ignored.

Table 3.2 shows the distribution of horizontal load between the panels and the columns. These results are based on analyses using a coarse mesh, so column shears are underestimated and panel shears overestimated. The shear distributions indicated in Table 3.2 demonstrate that for the cases tested,

the panels and the frame each resist a substantial portion of the load.

One objective of the test program was to determine if the strength of the panels is sufficient to resist the load their stiffness would attract. Since distress in the corrugated sheets almost never causes failure in a diaphragm test<sup>(57)</sup>, adequacy of the connections determines the adequacy of the diaphragm. Table 3.3 gives the calculated loads on the fillet welds joining the sheet to the marginal member. These forces are calculated with the total load on the frame adjusted so that the panel load is equal to the maximum allowable load for that thickness. The maximum allowable load is taken as the buckling load divided by 1.5. Calculation of the buckling load is discussed in section 3.6. The values in Table 3.3 are based on 30" of weld lumped at each node. The results demonstrate that the connections are adequate. The allowable weld loads are based on results given in Ref. 56. The maximum seam connection force is roughly six kips, which requires 1¼" of weld for 16 gauge and 2" for 20 gauge material at each connection. The weld strengths are based on the results in Ref. 51.

The values of the spring constants used for the end and edge connectors are not known precisely. To assess the influence of the spring constant, the medium frame with 16 gauge panels was analyzed using three different connection stiffnesses. The first three lines of Table 3.4 show the stiffnesses used and the resulting displacements. The insensitivity

of horizontal displacement to perimeter connection stiffness is evidence that uncertainty in its value does not affect conclusions drawn in this chapter. The fourth line of Table 3.4 gives the results of an analysis done with the spring constant for the marginal member spring on the vertical members made very stiff, to simulate a rigid connection. The practicality of the soft connection on the columns is questionable, so it is necessary to determine the influence of the horizontal spring constant. The analysis demonstrates that the results are little influenced by that stiffness.

To determine the sensitivity of panel behavior to the seam connector stiffness, the four different stiffnesses shown in the second, fifth, sixth and seventh lines of Table 3.4 are used. The results show the seam connections are more important than the perimeter connections. These results are combined to estimate the error resulting from non-linearity in the connector load-displacement behavior. If the load-deflection relation is assumed linear to some point and then linear at a lower stiffness, an estimate can be obtained. This was done assuming the initial stiffness to be 500 k/in. to  $.40P_U$ , with the stiffness decreasing to 400 k/in. thereafter and then again with the stiffness decreasing to 100 k/in. For the first case, the displacements differed from the linear analysis by 1.34%, for the second by 10.9%. The analyses were repeated raising the point at which the stiffness changes to  $.55P_U$ . For the 400 k/in. case, the displacements differ from

the linear by .57%. With the second stiffness reduced to 100 k/in., the displacements differ by 4.7%. It can be concluded that use of the initial stiffness results in acceptable errors.

The assumption has been made that little or no gravity load is transferred from the frame member to the trapezoidal panels. To check its validity, the medium frame is analyzed with three different spring constants for the flexible portion of the marginal member. Table 3.5 summarizes these calculations. The stiffness of 25.8 kips/in. in the top line is calculated assuming the inclined portion of the channel member shown in Fig. 3.2b to be a cantilever with a concentrated load at the end. For that stiffness, the vertical load transferred from frame to diaphragm is substantial. The value in the table is the maximum that occurs. With the connection stiffness reduced to one tenth of the value above, the load transferred is substantially reduced; with one hundredth of the stiffness above, load transfer is insignificant. The distribution of horizontal loads transferred to the panel is changed by the presence of the gravity load, if the marginal member inclined portion is too stiff. The distribution of horizontal gravity shear is similar to that in a beam; maximum at the ends and zero in the middle. Superimposing that distribution on the uniform shear resulting from lateral loading increases values of horizontal force on one side and decreases them on the other side. Table 3.5 shows that reducing the stiffness of the spring between frame and marginal member causes the

value of the maximum horizontal force in the connection to approach that of the lateral load case. These results demonstrate the importance of making the stiffness as small as possible. This is the main advantage of the detail shown in Fig. 3.2c. The spring constant is practically zero, since one channel is free to slide within the other.

One of the main objectives of the test program is to assess the accuracy of the corner only model over a wide range of parameters. The results of analyses of the six panel-frame combinations under lateral load for the corner only model and the fully connected model are shown in Table 3.6. The answers compare favorably. The largest errors are approximately four percent in the rotations. For the horizontal and vertical displacements, the discrepancies are generally less than  $1\frac{1}{2}\%$ . The corner only model gives an acceptably accurate prediction of the behavior of the panel-frame combination subjected to lateral load.

Table 3.7 shows the results obtained using the two different models in the frames with 16 gauge panels loaded with gravity and lateral loads. Agreement is good for the horizontal and vertical displacements, but poor for the rotations. The results obtained from the analyses using different stiffnesses for the flexible link between the marginal and frame members show that agreement improves as the stiffness is reduced. Again, the importance of a soft connection is demonstrated.

The results of an analysis using the corner only model will yield reasonably good results in spite of the errors in the rotations. The major percentage errors occur where the rotations are small and so would not substantially affect the deflections of the stories above. Analysis of a large multi-story frame under gravity and lateral loads gave approximately the same horizontal deflection as analysis of the same structure under only lateral load. It is not likely this would have happened if the effect of the errors in rotations is major. The errors become less severe as the size of the frame increases. For the heavy frame the errors are acceptable. For further work it is assumed that the magnitude of the errors is minimized by reducing the stiffness of the marginal member to frame link as much as possible and the remaining error will not significantly affect analyses using the corner-only model. Tables 3.6 and 3.7 indicate that the percentage errors are reasonably insensitive to frame size and thickness of panel.

### 3.6 Shear Buckling of the Infill

Shear buckling must be dealt with if light gauge panels are to be used in multistory frames. The approach taken here is to assume that the maximum allowable load on the panel is the calculated buckling load of the panel divided by an appropriate safety factor, say 1.5. The buckling load will be calculated using the work of Easley and McFarland<sup>(58)</sup>. They

represent a corrugated sheet as an orthotropic plate, which is consistent with the assumption made here that the sheet is modelled by orthotropic finite elements. Further, Easley and McFarland assume the diaphragm has sufficient fasteners along the edges and seams that overall buckling will take place, instead of local buckling or crippling. An approximate analysis is made using the Rayleigh-Ritz method to minimize the potential energy in the buckled configuration. Easley and McFarland do small and large deflection analyses. Here only small deflection equations are used, because they are simpler and give a reasonable estimate of the critical load. The equations used to calculate the buckling load are:

$$N_{CR} = \frac{D_x \pi^2}{b} \left[ 3\alpha + \frac{1}{\alpha} \left( \frac{D_x}{D_y} \right)^{\frac{1}{2}} \right] \quad (3.6)$$

where  $\alpha$  is the positive real root of:

$$8D_y^2 \alpha^8 + \frac{27}{4} D_y D_{xy} \alpha^6 + 11D_x D_y \alpha^4 - 3D_x D_{xy} \alpha^2 - D_x^2 = 0 \quad (3.7)$$

Figure 3.10 defines the problem. These equations are valid if  $D_y$  is greater than  $100D_x$  and  $D_x$  and  $D_{xy}$  are of the same order of magnitude. The panels dealt with here satisfy those conditions.

To avoid buckling, the designer would choose an infill with an allowable buckling load equal to or greater than the panel shear. There are other ways to avoid buckling. One would be to carry out the design of the frame and infills

represent a corrugated sheet as an orthotropic plate, which is consistent with the assumption made here that the sheet is modelled by orthotropic finite elements. Further, Easley and McFarland assume the diaphragm has sufficient fasteners along the edges and seams that overall buckling will take place, instead of local buckling or crippling. An approximate analysis is made using the Rayleigh-Ritz method to minimize the potential energy in the buckled configuration. Easley and McFarland do small and large deflection analyses. Here only small deflection equations are used, because they are simpler and give a reasonable estimate of the critical load. The equations used to calculate the buckling load are:

$$N_{CR} = \frac{D_x \pi^2}{b} \left[ 3\alpha + \frac{1}{\alpha} \left( \frac{D_x}{D_y} \right)^{\frac{1}{2}} \right] \quad (3.6)$$

where  $\alpha$  is the positive real root of:

$$8D_y^2 \alpha^8 + \frac{27}{4} D_y D_{xy} \alpha^6 + 11D_x D_y \alpha^4 - 3D_x D_{xy} \alpha^2 - D_x^2 = 0 \quad (3.7)$$

Figure 3.10 defines the problem. These equations are valid if  $D_y$  is greater than  $100D_x$  and  $D_x$  and  $D_{xy}$  are of the same order of magnitude. The panels dealt with here satisfy those conditions.

To avoid buckling, the designer would choose an infill with an allowable buckling load equal to or greater than the panel shear. There are other ways to avoid buckling. One would be to carry out the design of the frame and infills



without considering buckling and then adding stiffening members to the panel as required to obtain sufficient buckling capacity. However, the addition of extra members reduces the economy. The depth of the panel profile can be varied to obtain greater critical loads. The calculated buckling loads for 12, 16 and 20 gauge infills are given in Table 3.8 for the 1½" and 3" depths with the profiles shown in Fig. 3.11. These loads were calculated for an infill 30' wide and 10½' high, the clear height of the infills analyzed earlier. Increasing the depth of the panel increases the buckling load substantially, although adding to the amount of material used. The shear stiffness of the 3" section is not as great as that of the 1½" section, because the shear modulus decreases due to the increased ratio of developed width to flat width.

### 3.7 Conclusions

One of the main objectives of this chapter is to investigate the suitability of trapezoidal panels for use as infills in multistory frames. The results presented indicate that light gauge infills are suitable for that application. The analyses demonstrate that the strength of the infills is sufficient. Addition of panels leads to a substantial reduction in drift of the single bay, single story frames investigated. The next chapter demonstrates the same thing for multistory frames.

Another important aim was to develop an approximate model

of the infill-frame combination that would permit analysis of a clad frame with no more degrees of freedom than are required for analysis of a bare frame. Such a model was developed and its accuracy shown to be excellent for the frame-panel combination under lateral load only. Under the action of lateral load and gravity load, the rotations obtained from the approximate analysis do not agree well with those from the fully connected model. The accuracy of the rotations improves as the stiffness of the flexible link between the marginal member and frame member is reduced. For the combined load case, the accuracy of the horizontal and vertical deflections is acceptable. The conclusion is reached that the corner-only model can be used in multistory building analysis.

A way to calculate the buckling load of a trapezoidal panel has been given and the buckling loads for some practical sizes and sheet profiles presented. From the buckling loads calculated, it can be concluded that the panels are sufficiently resistant to buckling to be useful in multistory buildings.

CHAPTER 4  
BEHAVIOR OF PLANAR MULTISTORY FRAMES WITH  
LIGHT GAUGE STEEL INFILL PANELS

4.1 Analysis of Multistory Frames

The three story frame shown in Fig. 4.1 is used to demonstrate the analysis of multistory frames. Assume it is to be analyzed with 16 gauge diaphragms infilling all stories. The dimensions of the trapezoidal panel are shown in Fig. 3.11a for the 1½" panel. The diaphragm is connected to the frame by a 12 gauge cold-formed channel. The area of the channel is 0.629 in<sup>2</sup> and its moment of inertia 0.136 in<sup>4</sup>, the same marginal member properties used in the single story analyses done previously.

The areas used to develop the corner only model stiffness matrix are the sum of the actual marginal member area and the area of the lower story columns and girder. For example, the area assigned to the vertical edge members is 92.969 in<sup>2</sup>, the sum of the column area, 93.2 in<sup>2</sup> and the marginal channel area. The areas used are shown in Fig. 4.2.

The same panel stiffness matrix is used for all infills. Since the edge member area used to obtain the panel stiffness matrix is too large, the area input for the frame members must be reduced to maintain the correct total area. In the example

frame, the area of the vertical edge member was increased by  $92.3 \text{ in}^2$  so 92.3 is subtracted from the area input for the columns. The areas input for the example frame are shown in Fig. 4.2. The negative areas used arise from the need to maintain the correct total area. The bare frame deflects 1.69", the clad frame .344".

The edge member areas can be arbitrary except that they must be stiff enough axially to force the desired diaphragm behavior. Any members likely to be used in a multistory structure will be stiff enough. The properties of the infill would ideally be derived once and used for all the infills. For that to be possible, the results of the analysis should not be sensitive to the areas used. The same frame was reanalyzed using the areas shown in Fig. 4.3 to derive the panel stiffness. The resulting deflection is .354", indicating the choice of edge member areas does not affect the results significantly.

#### 4.2 Analysis of a 26 Story Frame with Infill Panels

To demonstrate the ability of light gauge steel infill panels to control drift effectively in a multistory frame, the 26 story frame shown in Fig. 4.4 is analyzed in detail. The frame was designed by a research group at Lehigh University directed by Prof. J. Hartley Daniels for use in American Iron and Steel Institute Project 174; "Effective Column Length and Frame Stability." The loads and dimensions used in the analyses are given in Fig. 4.4.

frame, the area of the vertical edge member was increased by  $92.3 \text{ in}^2$  so 92.3 is subtracted from the area input for the columns. The areas input for the example frame are shown in Fig. 4.2. The negative areas used arise from the need to maintain the correct total area. The bare frame deflects 1.69", the clad frame .344".

The edge member areas can be arbitrary except that they must be stiff enough axially to force the desired diaphragm behavior. Any members likely to be used in a multistory structure will be stiff enough. The properties of the infill would ideally be derived once and used for all the infills. For that to be possible, the results of the analysis should not be sensitive to the areas used. The same frame was reanalyzed using the areas shown in Fig. 4.3 to derive the panel stiffness. The resulting deflection is .354", indicating the choice of edge member areas does not affect the results significantly.

#### 4.2 Analysis of a 26 Story Frame with Infill Panels

To demonstrate the ability of light gauge steel infill panels to control drift effectively in a multistory frame, the 26 story frame shown in Fig. 4.4 is analyzed in detail. The frame was designed by a research group at Lehigh University directed by Prof. J. Hartley Daniels for use in American Iron and Steel Institute Project 174; "Effective Column Length and Frame Stability." The loads and dimensions used in the analyses are given in Fig. 4.4.

For these analyses, the stiffness matrices for a number of panels were developed. For most of the work, the panels were derived using the fine mesh idealization. Some of the first problems, which will be identified when they are discussed, were run using stiffness matrices developed from the coarse grid. Except when specifically mentioned, the member areas used to derive the panel stiffnesses are those for W14X314 columns and W24X84 beams. These sizes were chosen because they occur in the middle bay of the frame at approximately the mid-height of the structure. The trapezoidal sheets are of 12, 16 and 20 gauge with the dimensions shown in Fig. 3.11a.

The first test problem is run to check the sensitivity of displacements to the edge member stiffness used to derive the panel stiffness. The frame is analyzed using 16 gauge infills based on the coarse grid model. The frame was infilled full height in the middle bay. One analysis was conducted using panel properties based on W14X287 columns and W24X84 beams; another using properties for W12X58 columns and W21X49 beams. Because the analyses use the coarse grid, the displacements are not accurate, but the effect of edge members may be compared. For the frame using heavy edge members, the maximum horizontal displacement is 4.612"; for the frame using light edge members, the deflection is 4.655". The difference between the two solutions is just over 1%. This result and a similar one for the three story frame demonstrate that the

panel stiffness need be derived only once for each panel type in the structure.

To study frame behavior with realistic infills, the 26 story frame is analyzed using 12, 16 and 20 gauge infills full height in the middle bay. The displacements of the structure plotted versus height are shown in Fig. 4.5. The maximum deflection of the bare frame is about 10.1". With 20 gauge panels, the deflection is cut about 40%, to 5.9". The further reduction in deflection resulting from increased panel thickness is quite small compared to the amount of material added. For example, the change from 20 gauge to 12 gauge material increases the amount of material by 200% yet reduces the deflection of the frame only about 20%, from 5.9" to 4.7". On that basis, the thinner panel is more economical than a thicker panel. Because the seam connection stiffnesses are held constant for all thicknesses, increasing the thickness does not affect panel behavior proportionately. Similar behavior is evident in the single bay, single story results in Table 3.1 and in Ammar's work<sup>(51)</sup>. If the seam connector stiffness were changed along with the sheet thickness, the added material would prove more effective. However, the seam connection tests in Ref. 51 indicate very little change in the initial stiffness as the thickness of connected material is changed.

The reductions in drift obtained with all infill thicknesses are substantial. The deflection index for the bare frame is higher than most engineers consider acceptable, but

with the addition of panels it is reduced to a reasonable level. It is of interest to compare the drift reduction achieved using diagonals with that using panels. A single diagonal was added in the middle bay at every floor running from the lower left corner to the upper right corner of the panel. The area of the diagonal is  $10.0 \text{ in}^2$ . With these diagonals, the frame deflection was about  $5.0''$ , so the diagonals achieve roughly the same reduction as the 16 gauge panel. The diagonals add 1100 pounds of steel per floor, while the panels add 1250 lbs. The diagonals are slightly more efficient on this basis, and would have an even greater advantage if the cost of fabrication and erection is included in the comparison. Because the panel serves as a base for finishing material, economic comparisons depend on the value of this attribute.

Table 4.1 is a tabulation of the distribution of lateral load for the structure with 16 gauge infills. The percentage of shear carried by the panels remains relatively constant throughout the height of the structure, except for the topmost and bottommost few stories. The variations occur because the column and girder stiffnesses do not change uniformly over the height of the building. In a combined frame-shear wall structure, the shear wall resists a larger share of the horizontal load at the bottom of the structure than at the top<sup>(28)</sup>.

Table 4.1 shows that this does not happen in this case of an infilled frame. In this case, the relative increase of stiffness for the infilling and the frame toward the bottom are



about the same and the portion of load resisted by each remains the same.

With the shear loads on the panel known, buckling of the panels can be investigated. The buckling loads for the infills used in this analysis can be obtained from Table 3.8. The useful load on the panel is assumed to be the buckling load divided by 1.5. To determine if buckling is a problem, the calculated load on the panel is compared with the allowable load. For the 1½" deep, 16 gauge panel the allowable buckling load is 71.4 kips. From Table 4.1, it can be seen that the second to fourth floor infills carry loads greater than 71.4 kips. The depth or thickness of these panels would have to be increased or stiffening members added to the panel to avoid buckling. Because the upper story panels are well below the allowable buckling load, it would be worthwhile to use 18 or 20 gauge panels in the upper stories. A look at the shear distribution for the 12 gauge panels (Table 4.2) shows that buckling is not a problem for any of the 12 gauge panels. For the 20 gauge panels (Table 4.3), buckling is likely from the first floor to the fifteenth, indicating that 1½" deep, 20 gauge panels are not suitable for use in the lower portion of this structure.

Fig. 4.6a is a plot of the forces and moments in the windward column between the third and fourth floor under lateral load only. In Fig. 4.4, that column is labelled 'A'. The infills reduce the bending moments in the columns and beams,

reduce the axial load in the exterior columns, but increase it in the interior columns. It is better to look at the forces and moments in the frame under the action of lateral and gravity loads. Fig. 4.6b shows the bending moments and axial loads in the same column under combined loading for the unclad frame and the frame clad with 16 gauge infills. Again, the bending moments are reduced by the infills. Compared to the bare frame, addition of the infills unloads the windward column and loads the leeward column.

The details of the panel to frame connection are designed to prevent transfer of gravity load from girders to panels. If no gravity load is transferred, the forces and moments in the frame due to gravity load alone would not be affected by the panels. To demonstrate that fact, the forces and moments in the exterior girder on the fourth floor are shown in Figs. 4.7a and 4.7b, while the forces and moments in the windward interior column between the third and fourth floor are shown in Fig. 4.7c and 4.7d. In Fig. 4.4, the girder considered is labelled 'B' and the column 'A'. Comparing Fig. 4.7a for the clad frame with 4.7b for the bare frame, the forces and moments are seen to be essentially the same for the two cases. Reference to Figs. 4.7c and 4.7d shows that the same thing occurs in the column. These results show that the assumed idealization results in the desired behavior. Comparison of the axial loads in the columns shows that a portion of the gravity load is resisted by the panel, but it is small enough to be of no concern.

The presence of the panels will not affect the forces in the frame members only if the frame and its loading are symmetrical. If the geometry of the frame or the loading pattern cause side-sway, the presence of the panels will change the stresses in the frame members.

The single bay, single story analyses done to compare the accuracy of the approximate model with that of the exact model show large differences in the corner rotations for the case of combined gravity and wind loading. The results of the analyses of the 26 story frame under the action of lateral load only and combined load provide an indication that the effect of the discrepancies is not significant. The frame is infilled full height with 16 gauge panels. The deflection at the top of the frame with only wind load is 5.28". The same frame loaded with gravity and lateral loads deflected 5.30". If the error in the corner model rotations had a serious effect on the displacements, the difference in the horizontal displacement at the top of the frame would be greater.

No convergence curve is obtained for the 26 story frame. Results are obtained using the coarse and fine mesh models, but not the medium mesh. They indicate that the convergence curve for the 26 story building is similar to the single story, single bay curve of Fig. 3.6. The coarse grid model deflects 4.61" at the top, the fine grid model 5.28". Convergence from below is indicated, as before. The percentage difference is smaller because the frame, whose stiffness is the same in either model, plays a larger role.

#### 4.3 Design for Drift Control Using Light Gauge Steel Panels

A number of design philosophies could be followed in designing multistory frames with light gauge panel infills. The first would be to take advantage of the panels only to reduce the deflections of the frame. The frame would be designed to carry all loads, ignoring the presence of the infills. This is not to say that the panels do not resist some of the applied load. What is meant is that the frame will remain safe even if some panels are removed. The panels must be designed to resist whatever load their stiffness will attract. Frame members could be stressed more with the panels in place than without. For example, in the 26 story frame discussed earlier, the interior columns carry a higher axial load under combined loads in the clad frame than they do in the bare frame.

The second approach would be to require the unclad frame to resist 70 or 75% of the ultimate load. Panels would be added to control lateral deflections and to resist the balance of the ultimate load. Survival of the frame would be likely if the panels were removed. The strength of the panel would be utilized to a limited extent to reduce cost. A similar but less conservative approach would be to design the frame and the panels to reach their maximum load at the same displacement.

The most extreme approach would be to design the frames to resist only vertical loads, with the panels providing the

resistance to lateral load. No moment connections would be needed.

In the work described here, the first approach is utilized. The sole function of the panels is drift control. Design is done in the normal way and infills added where deflection considerations require them and architectural considerations permit them. The safety of the structure is not affected if any of the panels are removed, although serviceability may be impaired. Use of the other approaches in design must wait until a better understanding of the behavior of light gauge infills is obtained.

For symmetrical structures subjected to symmetrical loads, the addition of panels to the structure does not significantly affect behavior under gravity load alone. This fact has an important consequence in the design of the frame: the size of members whose design is controlled by gravity loads will not be affected by addition of infills. In the typical multistory frame of twenty to forty stories, the governing load condition will be gravity for the upper two thirds or half of the structure. The size of those members will not be affected regardless of which of the first three design approaches is chosen. The size of members whose design is controlled by gravity plus wind load will be affected by the panels. The same holds true for members in unsymmetrical frames or frames with unsymmetrical gravity loadings.

To design a structure using infill panels, the first step

is to design the frame to carry the loads. The design could be done by ultimate load methods or allowable stress methods. Then the deflections and deflection indices at service load levels (which may differ from the load level used in allowable stress design) are calculated. If all deflection indices are within an acceptable value, the design is finished. More commonly, deflection indices in the lower portion of the building will be excessive. If so, panels are added wherever required. A method to determine the size of the infill required is presented in section 4.4. The deflections are recalculated to insure that the deflection limitation is met. If necessary, the structure is modified and reanalyzed. The process is repeated until a satisfactory design is obtained.

#### 4.4 Approximate Method for Choosing Panel Stiffnesses

To minimize the number of cycles to achieve a satisfactory design, it is important to have an approximate design technique to select panel stiffnesses. A method considering an infilled story high segment of the structure as a pair of springs connected in parallel to a loaded rigid bar has been developed. Fig. <sup>4.8</sup>~~4.8~~ shows the structure. Since the deflection of each spring is the same, the load in each will be proportional to its stiffness. The spring constant for the frame and the infill must be known. Assume that Fig. <sup>4.9</sup>~~4.9~~ represents the load deflection curve for a story high segment. The segment stiffness is the slope of the curve. The shear carried

by the frame at the desired deflection can be found by proportion, as shown in the figure. The remainder of the total shear must be resisted by the panel. Since the deflection of the infill and the frame must be the same, the panel stiffness can be found by dividing the panel shear by the desired deflection.

To test the method, the 26 story frame analyzed previously is used. To begin, it was assumed the ninth story drift would be reduced to 1/500th of its height, and that all story drifts would be reduced by the same percentage. The predicted values and those obtained from an analysis for this problem are shown in Table 4.4. The values of  $V_F$ , the frame shear, given in column 4 are obtained by multiplying the total shear at a given floor by .288/.49. The values of  $V_P$ , the panel shear, in column six are gotten by subtracting  $V_F$  from the total shear given in column 3. The stiffness properties used for the panels were chosen to give for the corner deflection of the panel the predicted deflection given in col. 9 under a load equal to  $V_P$ .

The results are not very good. As columns six to ten show, the values obtained from the analysis do not check well with the predicted values. The errors are sizeable enough that the method would be of limited use. The problem was re-analyzed with the interior column areas set to a very large value, effectively eliminating column strains and the deflection of the frame due to them. The results are shown in Table 4.5. The agreement between the actual and the predicted values

is excellent, indicating that the approximate method is reasonable for a frame with a low height to width ratio, but not for a slender frame in which column strains play a major role in deflection.

The stiffness of the infill is chosen assuming the panel acts in pure shear. The corners of the panel remain at the same elevation before and after displacement. If column shortening is neglected, this happens in the infilled frame. However, if shortening is included, the corners of the infill do not remain at the same elevation during displacement. Additional shear forces are imposed on the panel due to change in its shape and additional deflection results.

The problem above attempts to reduce all story drifts by the same percentage. More often, the aim will be to reduce the drift of all stories to a common value. Tables 4.6 and 4.7 display the results of an analysis of the same frame assuming a maximum allowable story deflection of 1/500th of the height, or .288". Where the deflection of the bare frame is less than .288", it is arbitrarily reduced by a factor of .288/.32. The errors shown in columns 4 and 7 of Table 4.7 are acceptably small. If it can be assumed that deflection due to column shortening is negligible, the method enables an accurate choice to be made of the required panel stiffness to achieve a desired deflection.

For those cases in which deflections due to column strains are not negligible, the deflection of the bare frame due to



column strains is estimated using

$$\Delta_{cs} = \frac{wl^4}{6EI_0} \quad (4.1)$$

where  $I_0 = 2Ad^2$

A is the area of the columns at the base

d is one half of the base width.

See Spurr<sup>(59)</sup> for the derivation of this result, which assumes a uniform variation with height of the column areas. For the 26 story frame, the formula gives .845". Assuming the same portion of total deflection will arise from column strains in the infilled frame as in the bare frame, a value of .627" for the deflection due to column strains is obtained for the infilled frame. The deflection index for column strains is then .627/3740 or .00017. The desired deflection index is .0020, so the allowable deflection per story due to shear deflection is  $(.0020 - .00017) \times 144 = .264"$ . Implicit in this procedure is the assumption that every floor deflects an equal amount due to column shortening. The panel stiffnesses are chosen to achieve a deflection of .264" at every floor, neglecting column strains.

Tables 4.8 and 4.9 show the results of an analysis of the 26 story frame with panel stiffnesses chosen to give a deflection index of .0020 including column shortening. To illustrate the selection of the panel stiffnesses, the calculations for the twelfth floor are shown below.

$$V_F = \frac{.264}{.450} \times 106.2 = 62.4$$

$$V_P = 106.2 - 62.4 = 43.8$$

$$\text{Stiffness required is } \frac{.438}{.264} = 166 \text{ kips/in.}$$

As Table 4.9 shows, stiffnesses chosen in this way are very close to those required to reduce story drift to the desired value. The only significant errors are in those stories whose deflection in the bare frame is below the 1/500th limit. The predicted and actual shears do not agree well. This is to be expected, since the predicted shears are based on a smaller than actual predicted deflection to account for column shortening.

#### 4.5 Comments and Conclusions

The work described is concerned with frames infilled full height. It should be clear that there are many possible configurations for the infilling. Some are shown in Fig. 4.10. The patterns in Fig. 4.10a and 4.10b involve all columns more equally in resisting the horizontal load on the frame than does the pattern with infills in only one bay. This is an advantage in earthquake situations. The frame shown in Fig. 4.10d could be combined with another frame infilled only on even floors to form a staggered truss type structure. Because of the great number of variations possible, and the fact that architectural considerations are likely to determine permissible locations of panels, no attempt is made to include results

for many configurations.

The 26 story frame has been analyzed with infills at alternate floors in the middle bay, with the first panel at the first floor. The infills are 16 gauge. Although twice as many panels are used to infill full height, the reduction in deflection achieved is only 30% greater than for the frame infilled at alternate floors. If the limiting deflection is not too small, it may prove advantageous to use the alternate floor arrangement or a combination of panels every floor at the lower floors and on alternate floors for the balance of the building. More work is needed with different infill arrangements to establish the advantages and disadvantages of each.

The results presented in this chapter demonstrate that light gauge steel infills can be used to control drift in a multistory frame of realistic proportions. Whether or not the use of such infills is economically justified is a question to be answered by architects, engineers and metal deck manufacturers. Design of a tall building with infills is similar to the design of ordinary rigid frames and requires only slightly more effort. If use of the panels proves attractive, then a library of panel stiffness matrices could be developed by panel manufacturers for a wide variety of panel configurations and dimensions. The individual designer would never have to do the large scale analysis required to derive the panel stiffness matrix. With the library available, the analysis effort

required for an infilled structure is no greater than for a rigid frame building.

Another important result demonstrated in this chapter is the insensitivity of the deflections to the edge member areas used to derive the panel stiffness matrices. If this were not so, it would be necessary to rederive the panel properties every few floors of the structure to obtain acceptable accuracy. The cost of analysis would be increased considerably.

An approximate method has been presented for determining the infill stiffness required to achieve a given drift. The method is accurate for frames in which deflections due to column strains are negligible. For structures in which column strains are of moderate importance, the method can be modified to give good results. For very slender frames, with height to width ratios of four or greater, work is needed to determine the accuracy of the approximate method.

CHAPTER 5  
SUMMARY, CONCLUSIONS AND RECOMMENDATIONS

5.1 Summary

The research reported here attempts to develop means to analyze at service load conditions a multistory frame infilled with light gauge steel diaphragms. Linear, elastic behavior of all components is assumed. Based on the work of Ammar<sup>(51)</sup>, the trapezoidal sheets making up the infill panels are represented by orthotropic plane stress finite elements. The welds connecting sheet to sheet and sheets to frame are modelled by springs. The connection of the sheets to the marginal members is considered sufficient to prevent distortion of the panel profile at the ends. The shear modulus for the orthotropic elements is equal to the shear modulus of steel times the ratio of the flat width to the developed width of the panel.

Single bay, single story frames are used to study the suitability of light gauge panels to act in concert with steel rigid frames. To avoid buckling of the infill due to in-plane loading caused by gravity loads on the girders, the panel is connected to the frame in such a way that no load perpendicular to the frame member is transferred to the panel.

Behavior of infilled frames is studied using light, medium and heavy frames. Member sizes and frame dimensions were

chosen to be representative of those found in actual multi-story frames. Three thicknesses of sheet are used, 12, 16 and 20 gauge.

The degree of finite element mesh refinement necessary to achieve accurate results is determined by analyzing the structure using three different mesh sizes. To save on computer costs, the coarsest mesh is used for the single story studies, while the finest mesh is used to develop the panel stiffness matrices for most of the multistory work. The effect on displacements of varying the connector stiffnesses is investigated and found to be small. Results of single story, single bay test cases demonstrate that the use of light gauge infills to reduce drift is practical. Available predictions of the shear buckling load indicate buckling must be considered in the design.

An approximate panel model is developed which correctly predicts behavior of the infilled frame without the large number of degrees of freedom involved in the exact model. This model, which is connected to the frame only at the corners gives accurate results when the stiffness of the connection which prevents transfer of load perpendicular to the frame is sufficiently flexible. To calculate the stiffness properties of the approximate model, the marginal member areas must be increased.

Using a three story frame, the influence of assumed marginal member size on the lateral deflections is investigated.

The results of an analysis using light edge members agree within a few percent with those obtained using heavy edge members. To verify this result, a 26 story, three bay frame is analyzed using light and heavy edge members. The two analyses agree with each other within one percent.

Using the 26 story frame, the behavior of a multistory frame with light gauge infills is investigated. The frame is analyzed using 12, 16 and 20 gauge panels on all floors in the middle bay. The results indicate a 40 to 60% reduction in deflection is achieved by adding the infills, demonstrating their efficiency. The loads on the infills indicate that the 20 gauge infills are not suitable on the lower 15 floors because of the likelihood of buckling. The 16 gauge infills on the lower four floors are likely to buckle, while none of the 12 gauge panels are likely to buckle.

To assist the designer in determining the optimum location for panels and their required stiffness, an approximate analysis technique was developed. The portion of the load carried by the frame at the desired final deflection is found from its stiffness. The panels are sized to provide the shear capacity to resist the balance of the horizontal load on the frame.

## 5.2 Conclusions

The major conclusion of this investigation is that light gauge steel infill panels can be used to control drift. The

drift reductions achieved by infilling a multistory frame are substantial enough to justify the extra design complexity. Practical sizes and spacings of connections provide sufficient resistance to the loads on them.

The approximate model developed to reduce the number of degrees of freedom involved does so without significant loss of accuracy. Combined with the fact that assumed edge member properties do not have a significant effect on displacement, such an approximate model makes possible use of the same panel stiffness matrix throughout a structure, if all the panels are the same. Because the cost of deriving the panel stiffness matrix will often be more than the cost of analyzing the frame, reducing the number of different panel matrices is an important aid in reducing the cost of analysis. A library of stiffness matrices for panels of different depths, thicknesses, configurations and dimensions can be compiled. The stiffnesses can be made available to designers to carry out analyses at little extra cost compared to the analysis of an unclad frame.

The analyses of the 26 story frame indicate that shear buckling can occur at the loads to be expected in multistory structures. The panels used must be chosen to have an adequate safety factor against shear buckling. If the safety factor is not adequate, the designer can increase the panel thickness or depth, change the configuration to obtain a higher moment of inertia, or add stiffening elements to increase the buckling load.



The discrete element approach is a practical and effective means of analyzing the type of structure investigated here. The important parameters, such as connection stiffness and spacing, shear modulus of the trapezoidal sheets and properties of the framing members can be varied easily. The only experimentally determined data required are the shear modulus of the trapezoidal sheets and the spring constants of the fasteners.

The approximate "corner only" model and the fully connected model give the same results if the connection preventing transfer of gravity loads is very flexible. The more flexible the connection is, the more nearly transfer of transverse load from frame to panel is prevented. For these reasons development work on practical ways of constructing the infills should concentrate on developing connections that are as flexible as possible in the direction perpendicular to framing members.

The approximate method for choosing the required infill stiffness to give a desired deflection is a practical design tool which gives good results for the case tested. The method is accurate for frames in which the deflection due to column strains is of moderate or less importance. For slender frames, it is likely that further refinement in the method of dealing with column shortening is required.

### 5.3 Recommendations

Before the use of light gauge steel infills can be considered for actual use, more research is needed. The work

done in this investigation indicates that further work is justified. The recommendations made in this section fall into three groups.

The first group of recommendations deals with development work to be done by industry. A program to develop practical, effective connections between the frame and the panel is necessary. An effort should be made to develop practical construction techniques for infilled structures.

The emphasis in the research reported here has been on using existing floor or wall panels for the infilling. These are likely not the best shapes to use for infills. Research should be done to develop the most efficient profiles to resist in-plane shears. A waffle type section or a sandwich construction of steel over a light shear-resisting core might prove effective against buckling.

The second group of recommendations concerns further research into the behavior of light gauge diaphragms. The work of Ammar should be continued to develop better means to measure the elastic constants to be used in the finite element model of the diaphragm. In particular, attention should be given to determining the effective shear modulus to use in the orthotropic plane stress elements. The effect of connection non-linearities should be included in the analysis in future work.

The analytical work of Easley and McFarland<sup>(58)</sup> and others on shear buckling of diaphragms should be refined and more

experimental work done to confirm the analytical research. Experimental studies should be made to determine the minimum size and spacing of connections to prevent distortion of the panel profile at the ends.

The final recommendations are aimed specifically at research to be done on light gauge steel infills. Because of the growing importance of limit load approaches to design, attention should be given to the behavior of infilled frames at ultimate loads. The effect of the panels on the failure mode and failure level should be determined. To do this, it will be necessary to include the P- $\Delta$  effect in the analysis. The possibility of utilizing the infills to brace the columns against buckling should be investigated.

Door and window openings are likely to have an important effect on infill stiffness. Research is necessary to determine how serious that effect is and to find a simple way to modify the panel stiffness matrix to account for the opening. The finite element model permits openings to be accounted for simply by removing elements and adding framing members if required. Another aspect of this work would be to determine the structural requirements of the framing members.

The dynamic behavior of infilled frames should be studied. The response of an infilled frame subjected to earthquake loading should be examined. An important aspect of this work is determination of the damping properties of the infilled structure. Additionally, the vibrations of the infilled building

under wind loads should be investigated.

A systematic study of different structures with light gauge infilling should be conducted with a view towards establishing the range of structures for which the infills are suitable. The variables in this study should include height to width ratio of the building, number of stories, floor to floor height, bay width, number of bays and type of occupancy. Included in this study should be work on three dimensional structures with infills.

The convergence behavior of analyses of infilled multi-story frames should be examined. The work reported here suggests that multistory solutions converge in the same fashion as the single story solutions. A systematic study of convergence of infilled frame analyses should be made to confirm the work done here.

First priority in future research should be given to a series of large scale tests of one or two story infilled frames. The tests would provide a comparison between analytical predictions and actual behavior. They would offer an opportunity to compare the effectiveness of different types of panel to frame connections. At the same time, experiments should be made on small scale specimens to develop suitable connections. The large scale test would permit a comparison of predicted buckling load with the buckling load determined experimentally.

## REFERENCES

1. Rathbun, J. C., "Wind Forces on a Tall Building," Transactions of the American Society of Civil Engineers, V. 105, p. 1, 1940.
2. Wiss, J. F. and Curth, O. E., "Wind Deflections of Tall Concrete Frame Buildings," Journal of the Structural Division, Proceedings of the American Society of Civil Engineers, V. 96, No. ST7, p. 1461, July 1970.
3. ———, "Research Needs in Structural Engineering for the Decade 1966-1975," Journal of the Structural Division, Proceedings of the American Society of Civil Engineers, V. 92, No. ST5, p. 287, October 1966.
4. Fleming, J. F., Podolny, W. Jr., and Rile, T. S., "Drift Study of Tapered Frameworks," Civil Engineering, V. 37, No. 8, p. 38, Aug. 1967.
5. Douglass, M. and Torrealba, J., "Efficient Design of High-Rise Steel Buildings," Paper presented at the Annual Meeting of the Engineering Institute of Canada, Sept. 1971.
6. Carmody, Deirdre, "Like Ships at Sea, Skyscrapers Creak on a Gusty Day," New York Times, V. CXXI, No. 41650, p. 31, Feb. 5, 1972.
7. Eligator, M. H. and Nassetta, A. F., "Chapter 19-Part 3 Multistory Buildings," Structural Engineering Handbook, Gaylord, E. H. and Gaylord, C. N., Ed., New York, McGraw-Hill, 1968.
8. ———, National Building Code of Canada 1970, National Research Council of Canada, Ottawa, 1970.
9. ———, "Canadian Structural Design Manual," Supplement No. 4 to the National Building Code of Canada, National Research Council of Canada, Ottawa, 1970.
10. Chang, F. K., "Wind and Movement in Tall Buildings," Civil Engineering, V. 37, No. 8, p. 70, Aug. 1967.

11. Waller, R. A., "The Design of Tall Structures with Particular Reference to Vibration," Proceedings of the Institution of Civil Engineers, V. 48, p. 303, Feb. 1971.
12. duPlessis, D. P. and Daniels, J. H., Performance Design of Tall Buildings for Wind, Fritz Engineering Laboratory Report No. 376.1, Lehigh University, June 1971.
13. Clough, R. W., Wilson, E. L., and King, I. P., "Large Capacity Multistory Frame Analysis Programs," Journal of the Structural Division, Proceedings of the American Society of Civil Engineers, V. 89, No. ST4, p. 179, August 1963.
14. Clough, R. W., King, I. P. and Wilson, E. L., "Structural Analysis of Multistory Buildings," Journal of the Structural Division, Proceedings of the American Society of Civil Engineers, V. 90, No. ST3, p. 19, June 1964.
15. Clough, R. W. and King, I. P., "Analysis of Three Dimensional Building Frames," Publications of the International Association for Bridge and Structural Engineering, V. 24, p. 15, 1964.
16. Weaver, W. Jr. and Nelson, M. F., "Three dimensional Analysis of Tier Buildings," Journal of the Structural Division, Proceedings of the American Society of Civil Engineers, V. 92, No. ST6, p. 385, Dec. 1966.
17. Logcher, R. D. et al., Ices Strudl-II The Structural Design Language Engineering User's Manual Volume 1, Frame Analysis, Research Report R68-91, Department of Civil Engineering, School of Engineering, Massachusetts Institute of Technology, Nov. 1968.
18. Logcher, R. D., Connor, J. J. Jr. and Ferrante, A. J., Ices Strudl-II The Structural Design Language Engineering User's Manual Volume 2 Additional Design and Analysis Facilities, Research Report R68-92, Department of Civil Engineering, School of Engineering, Massachusetts Institute of Technology, June 1969.
19. MacNeal, R. H. and McCormick, C. W., "The Nastran Computer Program for Structural Analysis," Computers and Structures, V. 1, No. 3, p. 389, Oct. 1971.
20. Schwaighofer, J. and Microys, H. F., "Analysis of Shear Walls Using Standard Computer Programs," Journal of the American Concrete Institute, V. 66, No. 12, p. 1005, Dec. 1969.

21. Coull, A. and Puri, R. D., "Analysis of Pierced Shear Walls," Journal of the Structural Division, Proceedings of the American Society of Civil Engineers, V. 94, No. ST1, p. 71, Jan. 1968.
22. Coull, A. and Choudhury, J. R., "Stresses and Deflections in Coupled Shear Walls," Journal of the American Concrete Institute, V. 64, No. 2, p. 65, Feb. 1967.
23. Rosman, R., "Approximate Analysis of Shear Walls Subject to Lateral Load," Journal of the American Concrete Institute, V. 61, No. 6, p. 717, June 1964.
24. Rosman, R., "Pierced Walls Subject to Gravity Loads," Concrete, V. 2, No. 6, p. 252, June 1968.
25. Girijavallabhan, C. V., "Analysis of Shear Walls with Openings," Journal of the Structural Division, Proceedings of the American Society of Civil Engineers, V. 95, No. ST10, p. 2093, Oct. 1969.
26. McLeod, I. A., "New Rectangular Finite Element For Shear Wall Analysis," Journal of the Structural Division, Proceedings of the American Society of Civil Engineers, V. 95, No. ST3, p. 399, Mar. 1969
27. Weaver, W. Jr. and Oakberg, R. G., "Analysis of Frames with Shear Walls by Finite Elements," Proceedings of the Symposium on Application of Finite Element Methods in Civil Engineering, Rowan, W. H. Jr. and Hackett, R. M., Ed., Nashville, Tenn., Nov. 1969.
28. Khan, F. R. and Sbarounis, J. A., "Interaction of Shear Walls and Frames," Journal of the Structural Division, Proceedings of the American Society of Civil Engineers, V. 90, No. ST3, p. 385, June 1964.
29. Weaver, W. Jr., Brandow, G. E., and Manning, T. A. Jr., "Tier Buildings with Shear Cores, Bracing and Setbacks," Computers and Structures, V. 1, No. 1/2, p. 7, Aug. 1971.
30. Barsoum, R. S., The Stiffening Effect of Cladding on Multistory Buildings, Master's Thesis, Cornell University, 1968.
31. Stafford-Smith, B., "A Method of Analysis for Infilled Frames," Proceedings of the Institution of Civil Engineers, V. 44, p. 31, Sept. 1969.

32. Stafford-Smith, B., "The Composite Behavior of Infilled Frames," Tall Buildings--Proceedings of a Symposium held at the University of Southampton, Coull, A., and Stafford-Smith, B., Ed., p. 340, April 1966.
33. Karamanski, T., "Calculating Infilled Frames by the Method of Finite Elements," Tall Buildings--Proceedings of a Symposium held at the University of Southampton, Coull, A. and Stafford-Smith, B., Ed., p. 455, April 1966.
34. Mallick, D. V. and Severn, R. T., "The Behavior of Infilled Frames under Static Loading," Proceedings of the Institution of Civil Engineers, V. 38, p. 639, Dec. 1967.
35. Pian, T. H. H., "Derivation of Element Stiffness Matrices by Assumed Stress Distributions," Journal of the American Institute of Aeronautics and Astronautics, V. 2, No. 7, p. 1333, July 1964.
36. McGuire, W., The Stiffening Effect of Cladding on Multi-story Frames, Report Prepared for the American Iron and Steel Institute, Oct. 1967.
37. Nilson, A. H., "Shear Diaphragms of Light Gage Steel," Journal of the Structural Division, Proceedings of the American Society of Civil Engineers, V. 86, No. ST11, p. 111, Nov. 1960.
38. Luttrell, L. D., Strength and Behavior of Light Gage Steel Shear Diaphragms, Cornell University Engineering Research Bulletin 67-1, July 1967.
39. Bryan, E. R. and El-Dakhakhni, W. M., "Behavior of Sheeted Portal Frame Sheds: Theory and Experiments," Proceedings of the Institution of Civil Engineers, V. 29, p. 743, Dec. 1964.
40. Bryan, E. R. and El-Dakhakhni, W. M., "Shear of Thin Plates with Flexible Edge Members," Journal of the Structural Division, Proceedings of the American Society of Civil Engineers, V. 90, No. ST4, p. 1, Aug. 1964.
41. Bryan, E. R. and Jackson, P., "The Shear Behavior of Corrugated Steel Sheeting," Proceedings of a Symposium on Thin Walled Steel Structures, Swansea, Sept. 1967.
42. Horne, M. R. and Raslan, R. A. S., "An Energy Solution to the Shear Deformation of Corrugated Plates," Publications of the International Association for Bridge and Structural Engineering, V. 31-I, p. 51, 1971.



43. Horne, M. R. and Raslan, R. A. S., "A Finite Difference Approach to Corrugated Shear Panels," Publications of the International Association for Bridge and Structural Engineering, V. 31-I, p. 73, 1971.
44. Pincus, G. and Fisher, G. P., The Performance of Beams and Columns Continuously Braced with Diaphragms, Report No. 312, Dept. of Struct. Eng., School of Civil Engineering, Cornell University, Feb. 1963.
45. Fisher, G. P. and Pincus, G., The Performance of Beams and Columns Continuously Braced with Diaphragms, Report No. 313, Dept. of Struct. Eng., School of Civil Engineering, Cornell University, Sept. 1963.
46. Errera, S. J. and Fisher, G. P., The Performance of Beams and Columns Continuously Braced with Diaphragms, Report No. 316, Dept. of Struct. Eng., School of Civil Engineering, Cornell University, Aug. 1964.
47. Errera, S. J., The Performance of Beams and Columns Continuously Braced with Diaphragms, Report No. 321, Dept. of Struct. Eng., School of Civil Engineering, Cornell University, Oct. 1965.
48. Pincus, G. and Fisher, G. P., "Behavior of Diaphragm Braced Columns and Beams," Journal of the Structural Division, Proceedings of the American Society of Civil Engineers, V. 92, No. ST2, p. 323, April 1966.
49. Errera, S. J., Pincus, G. and Fisher, G. P., "Columns and Beams Braced by Diaphragms," Journal of the Structural Division, Proceedings of the American Society of Civil Engineers, V. 93, No. ST1, p. 295, Feb. 1967.
50. Apparao, T. V. S. R., Tests on Light Gauge Steel Diaphragms, Report No. 328, Dept. of Struct. Eng., School of Civil Engineering, Cornell University, Dec. 1966.
51. Ammar, A. R., Analysis of Light Gauge Steel Shear Diaphragms, Technical Report, Dept. of Struct. Eng., School of Civil Engineering, Cornell University (in preparation).
52. Irons, B. M., "A Frontal Solution Program for Finite Element Analysis," International Journal for Numerical Methods in Engineering, V. 2, No. 1, p. 5, Jan.-Mar. 1970.
53. Cantin, G., "An Equation Solver of Very Large Capacity," International Journal for Numerical Methods in Engineering, V. 3, No. 3, p. 379, July-Sept. 1971.

54. Maghsood, J., Finite Element Analysis of Wood Beams, Doctoral Dissertation, Cornell University, 1970.
55. Przemienicki, J. S., Theory of Matrix Structural Analysis, New York, McGraw-Hill, 1968.
56. Dhalla, A. K. and Pekoz, T., Tests on Puddle and Fillet Weld Connections, Report Prepared for the American Iron and Steel Institute, Oct. 1971.
57. Nilson, A. H., Discussion of "Buckling of Light-Gauge Metal Shear Diaphragms" by Easley, J. T. and McFarland, D., Journal of the Structural Division, Proceedings of the American Society of Civil Engineers, V. 95, No. ST12, p. 3004, Dec. 1969.
58. Easley, J. T. and McFarland, D., "Buckling of Light-Gauge Metal Diaphragms," Journal of the Structural Division, Proceedings of the American Society of Civil Engineers, V. 95, No. ST7, p. 1497, July 1969.
59. Spurr, H. V., Wind Bracing, New York, McGraw-Hill, 1930.
60. Zienkiewicz, O. C., The Finite Element Method in Engineering Science, London, McGraw-Hill, 1971.
61. Wang, P. C., Numerical and Matrix Methods in Structural Mechanics, New York, John Wiley & Sons Inc., 1966.



ENTIRE STRUCTURE.

SUBASSEMBLY NUMBERING SYSTEM- THE NUMBERS, STARTING AT ONE AND RUNNING CONSECUTIVELY, WHICH IDENTIFY THE SUBASSEMBLY DEGREES OF FREEDOM.

ELEMENT NUMBERING SYSTEM - THE NUMBERS WHICH IDENTIFY THE ELEMENT DEGREES OF FREEDOM, STARTING AT ONE AND RUNNING CONSECUTIVELY.

ANY SIZE STRUCTURE CAN BE ANALYZED, HOWEVER, THE FOLLOWING LIMITATIONS EXIST IN THE PROGRAM AS LISTED:

1. THE WAVEFRONT MUST BE LESS THAN OR EQUAL TO 80 VARIABLES. IF A LARGER WAVEFRONT IS REQUIRED, THE DIMENSION OF THE VECTOR MVABL IN COMMON BLOCK 11 (SEE TABLE A1 FOR A LISTING OF COMMON BLOCKS USED IN THE PROGRAM AND WHICH OF THE SUBROUTINES EACH APPEARS IN) MUST BE INCREASED. IN ADDITION, THE VARIABLE MVEND IN THE MAIN ROUTINE SHOULD BE INCREASED TO HAVE THE SAME SIZE AS THE DIMENSION OF VECTOR MVEND. SEE REF. 52 TO FIND OUT HOW TO CALCULATE THE LENGTH OF THE WAVEFRONT.

2. THE NUMBER OF SUBASSEMBLIES WITH DIFFERENT STIFFNESS MATRICES MUST BE LESS THAN OR EQUAL TO 16. IF A LARGER NUMBER IS REQUIRED, THE DIMENSION OF THE VECTOR LOC IN COMMON BLOCK 32 MUST BE CHANGED. THE UPPER HALF TRIANGLE OF THE SUBASSEMBLY STIFFNESS AND LOAD MATRICES ARE STORED IN VECTOR STORE. THE TOTAL LENGTH OF ALL DIFFERENT SUBASSEMBLY STIFFNESS MATRICES AND LOAD MATRICES CANNOT EXCEED 2100 UNLESS THE DIMENSION OF VECTOR STORE IN COMMON BLOCK 32 IS INCREASED. THE AMOUNT OF STORAGE REQUIRED FOR EACH SUBASSEMBLY IS:

$$L = (NDOF + 1) * NDOF / 2 + NDOF * NLC \quad (A1)$$

WHERE L = AMOUNT OF STORAGE REQUIRED

NDOF = NO. OF DEGREES OF FREEDOM IN SUBASSEMBLY

NLC = NO. OF LOAD CASES

3. THE NUMBER OF DIFFERENT KINDS OF MEMBERS IN THE STRUCTURE CANNOT EXCEED 32. IF A LARGER NUMBER IS REQUIRED, THE THIRD DIMENSION OF MATRIX SSK IN COMMON BLOCK 53 SHOULD BE INCREASED AS REQUIRED.

AS WRITTEN, IT IS THE RESPONSIBILITY OF THE USER TO ENSURE THAT THE PROPER UNITS ARE USED. ANY CONSISTENT SET OF UNITS CAN BE USED. THE PROGRAM DOES NO CONVERSION OF UNITS.

THE EQUATION SOLUTION ROUTINE USED IN THE PROGRAM WAS CODED BY BRUCE IRONS AND IS FULLY DESCRIBED AND DOCUMENTED IN REF. 52. THIS PROGRAM CONSISTS OF IRONS

C ROUTINE AND 12 SUBROUTINES. THE PROGRAM IS DOCUMENTED  
C WITH AN EXPLANATION OF THE FUNCTION OF EACH SUBROUTINE  
C AT THE BEGINNING OF THE SUBROUTINE. THE ARGUMENTS OF  
C THE SUBROUTINE ARE DEFINED AND EXPLAINED. ALL INPUT AND  
C OUTPUT STATEMENTS ARE NOTED AND THE VARIABLES IN THEM  
C DEFINED. FIGS. A9-A21 CONTAIN MACRO FLOW CHARTS FOR  
C ALL SUBROUTINES. AFTER THE LISTING, THE ORGANIZATION OF  
C THE DATA IS EXPLAINED AND THE DATA FOR A SIMPLE FRAME  
C SHOWN.  
C  
C  
C

C THE PROGRAM MAKES WIDE USE OF AUXILIARY STORAGE,  
C EITHER TAPE OR DISK. THE DIMENSION STATEMENTS IN THE  
C PROGRAM HAVE BEEN SIZED ON THE BASIS OF A BLOCK SIZE OF  
C 7294 BYTES. THE 7294 BYTE BLOCK SIZE LIMITS THE SIZE OF  
C ELEMENTS AND SUBASSEMBLIES TO NO MORE THAN 40 DEGREES  
C OF FREEDOM. THE PROGRAM REQUIRES THREE SCRATCH DISK  
C DATA SETS, UNITS 1, 2, AND 3.  
C  
C

C BEFORE BEGINNING THE DOCUMENTATION OF THE LISTING,  
C SOME OF THE IMPORTANT VARIABLES IN THE PROGRAM WILL BE  
C DEFINED. VARIABLES WHICH APPEAR IN READ AND WRITE  
C STATEMENTS ARE DEFINED WHERE THEY FIRST APPEAR IN THE  
C LISTING. THE VARIABLES ARE GROUPED ACCORDING TO THE  
C SUBROUTINE IN WHICH THEY APPEAR. VARIABLES WHICH APPEAR  
C IN THE DEFINITIONS ARE DEFINED IN THE DEFINITIONS OF  
C SUBROUTINE ARGUMENTS OR IN INPUT STATEMENTS.  
C  
C

C VARIABLES APPEARING IN ELMAC:

C TRANS = MATRIX TO TRANSFORM THE STIFFNESS MATRIX  
C OF A DIAGONAL MEMBER FROM LOCAL TO GLOBAL COORDS.  
C SSK = THREE DIMENSIONAL MATRIX USED TO STORE THE  
C STIFFNESS MATRIX OF ELEMENTS WHICH APPEAR MORE  
C THAN ONCE IN THE STRUCTURE.  
C TC = MATRIX USED IN TRANSFORMATION OF COLUMN ELE-  
C MENT STIFFNESS MATRIX TO ACCOUNT FOR RIGID FLOORS.  
C FLK = FINAL STIFFNESS MATRIX OF COLUMN AFTER TRAN-  
C SFORMATION TO ACCOUNT FOR RIGID FLOORS IF NO RE-  
C LEASED DEGREES OF FREEDOM ARE INVOLVED.  
C TP = MATRIX USED IN TRANSFORMATION OF PLATE ELE-  
C MENT STIFFNESS TO ACCOUNT FOR RIGID FLOORS.  
C PLKR = FINAL STIFFNESS MATRIX OF PLATE ELEMENT  
C AFTER TRANSFORMATION TO ACCCOUNT FOR RIGID FLOORS  
C IF NO RELEASED DEGREES OF FREEDOM ARE INVOLVED.  
C TD = MATRIX USED IN TRANSFORMATION OF DIAGONAL  
C MEMBER STIFFNESS TO ACCOUNT FOR RIGID FLOORS.  
C DIAG = FINAL STIFFNESS MATRIX OF DIAGONAL MEMBER  
C AFTER TRANSFORMATION TO ACCOUNT FOR RIGID FLOOR,  
C IF NO RELEASED DEGREES OF FREEDOM ARE INVOLVED.  
C TCT = INTERMEDIATE MATRIX TAKEN FROM TC, TP OR TD  
C WITH RELEASED DEGREES OF FREEDOM ELIMINATED.  
C STIFF = FINAL STIFFNESS MATRIX FOR COLUMN, BEAM OR  
C PLATE ELEMENT IF RELEASED DEGREES OF FREEDOM ARE  
C INVOLVED.

C EL = VECTOR CONTAINING ELEMENT STIFFNESS AND LOAD  
C MATRICES WHICH IS WRITTEN ON TAPE AT THE END OF  
C ELMK

C VARIABLES APPEARING IN MINV:

C U = SQUARE MATRIX WHICH IS A UNIT MATRIX THE SIZE  
C OF MATRIX A, AT THE BEGINNING OF MINV. AT THE END  
C OF MINV, U CONTAINS THE INVERSE OF A.  
C EPS = A VARIABLE USED TO DETERMINE IF DIAGONAL  
C ELEMENTS ARE ZERO.

C VARIABLES APPEARING IN RELMEM:

C MRD = VECTOR WHICH IDENTIFIES THE DEGREES OF FREE-  
C DOM WHICH ARE TO BE ELIMINATED.  
C RR AND RRI = MATRICES CORRESPONDING TO MATRIX  
C K(F,F) IN EQN 3.1. RRI BECOMES THE INVERSE OF RR  
C AFTER MINV IS CALLED.  
C RF = MATRIX CORRESPONDING TO MATRIX K(F,S) IN EQN  
C 3.1.  
C FF = MATRIX CORRESPONDING TO MATRIX K(S,S) IN EQN  
C 3.1.  
C SMOD = PRODUCT OF (RF TRANSPOSE)\*RRI\*RF. CORRES-  
C POND TO THE SECOND TERM OF EQN 3.5.

C VARIABLES APPEARING IN FORCE:

C NOEL = NELEM = ELEMENT NUMBER.  
C DISP = VECTOR CONTAINING ELEMENT DISPLACEMENTS.  
C NTORE = VECTOR USED TO STORE SUBASSEMBLY DATA  
C WHICH MAY BE NEEDED FOR A LATER, IDENTICAL SUBAS-  
C SEMBLY.  
C FOR = MATRIX CONTAINING THE CALCULATED MEMBER  
C FORCES.  
C KKUREL = TOTAL NUMBER OF ACTIVE DEGREES OF FREEDOM  
C WHICH IS EQUAL TO KURELS+NAD OR KUREL+NRD.

C VARIABLES APPEARING IN FORCE1:

C NTORE = 3D MATRIX USED TO STORE INFORMATION FOR  
C CALCULATING MEMBER RELEASES.  
C STIF = THE ELEMENT STIFFNESS MATRIX AFTER RETRIE-  
C VAL FROM SSK  
C DISP1 = VECTOR DISP CONVERTED TO A MATRIX FOR USE  
C IN THE MATRIX MULTIPLICATION ROUTINE.

C VARIABLES APPEARING IN STIGEN:

C NPMAX = LENGTH OF UPPER HALF TRIANGLE OF STIFFNESS  
C MATRIX WHEN STORED COLUMNWISE AS A VECTOR.  
C LZ = NPMAX + LOAD MATRIX STORED COLUMNWISE AS A  
C VECTOR  
C STEFF = VECTOR OF LENGTH LZ CONTAINING STIFFNESS  
C AND LOAD MATRICES.  
C STORE = VECTOR WHICH STORES THE SUBASSEMBLY STIFF-  
C NESS MATRIX FOR LATER USE.

C THE MAIN FUNCTIONS OF THE MAIN ROUTINE ARE TO CAR-  
 C RY OUT THE ASSEMBLY OF ELEMENT STIFFNESS CONTRIBUTIONS  
 C AND ELIMINATION OF VARIABLES AND THEN THE BACKSUBSTITU-  
 C TION PHASE. HOWEVER, THE MAIN ROUTINE FIRST READS THE  
 C NUMBER OF DEGREES OF FREEDOM AND THEIR IDENTIFICATION  
 C IN THE STRUCTURE SYSTEM FOR ALL ELEMENTS AND/OR SUBAS-  
 C SEMBLIES AND STORES THIS INFORMATION IN VECTOR NIX FOR  
 C FOR FUTURE USE. AFTER THAT, MAKING USE OF SUBROUTINES  
 C ELMAK AND STIGEN, THE ELEMENT AND SUBASSEMBLY STIFFNESS  
 C MATRICES ARE GENERATED AND STORED IN AUXILIARY STORAGE.  
 C ONCE THIS IS DONE, THE ASSEMBLY AND BACKSUBSTITUTION  
 C PHASES ARE DONE. THE FINAL FUNCTION OF THE MAIN ROU-  
 C TINE IS PRINTING THE DISPLACEMENTS AND REACTIONS. IF  
 C MEMBER FORCES ARE REQUIRED, SUBROUTINE FORCE IS CALLED  
 C TO CALCULATE AND PRINT THEM OUT.

C  
 C IMPLICIT REAL\*8(A-H,O-Z)  
 C DIMENSION P(40),JJ(40),NR(40),NRA(40),JM(4200)  
 C DIMENSION NIX(12000),COORD(3,100)  
 C COMMON /BLK10/ ELPA(12000),ELCOR(3,4),EL(900),BMK(12,1  
 C 2),  
 C 1 CLK(12,12),PLK(12,12)  
 C COMMON /BLK13/ FLK(12,12),PLKR(12,12)  
 C COMMON /BLK11/ MVABL(80),LVABL(80),LND(80),LDEST(80),L  
 C RD(12)  
 C COMMON /BLK82/ LFORCE(500)  
 C COMMON /BLK32/ STORE(2100),LOC(16)  
 C COMMON /BLK12/ INITL,NTIREX,NEWRHS,NELEM,NELEMZ,KUREL,  
 C LPREQ,  
 C 1 LZ,NELZ,NBAXO,NBZ,KL,LDES,NSTRES,KK  
 C COMMON /BLK14/ LOAD  
 C COMMON /BLK15/ NTYPE,NRD  
 C COMMON /BLK31/ KE,KL1,NAD,NE  
 C COMMON /BLK81/ NRE,KL2,NFORCE  
 C EQUIVALENCE (JM(1),STORE(1))  
 C EQUIVALENCE (NIX(1),ELPA(1))  
 C NFUNC(I,J)=I+(J\*(J-1))/2  
 C NELPAZ = 12000  
 C LVEND=80  
 C MVEND=80  
 C NIXEND = 10800  
 C 2 INITL=1  
 C LOC(1) = 1  
 C 5001 READ (5,804) (JJ(I), I = 1,40)

C  
 C THIS INPUT STATEMENT READS IN A TITLE SUPPLIED BY  
 C THE ANALYST. TWO CARDS MUST BE USED EVEN IF ONLY ONE IS  
 C NEEDED FOR THE TITLE. ANY CHARACTERS ACCEPTABLE TO FOR-  
 C TRAN IV MAY BE USED IN ANY COMBINATION. THE TITLE WILL  
 C BE PRINTED OUT EXACTLY AS IT IS READ IN.

C  
 C 804 FORMAT (20A4)  
 C  
 C 5002 READ (5,900) NEWRHS,NTIREX,NRMAX,MAXTAP,MAXELT,NFORCE

```

C
C     THIS INPUT STATEMENT READS IN THE BASIC DATA RE-
C     QUIRED FOR THE PROGRAM. THE VARIABLE DEFINITIONS ARE:
C     NEWRHS = NUMBER OF LOAD CASES
C     NTIREX = 0 IF OUTPUT IS TO BE ELEMENT BY ELEMENT.
C             1 IF OUTPUT IS FOR THE WHOLE STRUCTURE AT
C             ONCE. AS THE PROGRAM IS SET UP, NTIREX SHOULD BE 1
C     NRMAX = MAXIMUM NUMBER OF LOAD CASES. FOR LINEAR
C     ANALYSES IT SHOULD BE THE SAME AS NEWRHS. IF THE
C     PROGRAM IS MODIFIED TO DO ITERATIVE ANALYSES,
C     NRMAX WILL BE DIFFERENT THAN NEWRHS.
C     MAXTAP = VARIABLE USED TO SET UP WORKING SPACE IN
C     THE PROGRAM. USE 8000.
C     MAXELT = MAXIMUM LENGTH OF ELEMENT STIFFNESS MA-
C     TRIX PLUS LOAD VECTOR. TAKE EQUAL TO 900 FOR PRO-
C     GRAM DIMENSIONED AS LISTED.
C     NFORCE = 0 IF NO MEMBER FORCES ARE DESIRED.
C             1 IF ANY MEMBER FORCES ARE TO BE FOUND.
C
C     WRITE (6,802)
802  FORMAT (6X,26HBEGINNING OF A NEW PROBLEM)
C
C     THIS STATEMENT WRITES OUT "BEGINNING OF A NEW PRO-
C     BLEM" IN ORDER TO SEPARATE DIFFERENT PROBLEMS.
C
C     WRITE (6,950)
950  FORMAT (1H0)
C     WRITE (6,951) (JJ(I),I=1,40)
C
C     THIS STATEMENT WRITES OUT THE TITLE WHICH WAS READ
C     IN READ STATEMENT 5001.
C
951  FORMAT (1X,20A4)
C     WRITE (6,950)
C     JWHERE=1
C     IF(NELPAZ.LE.0. OR .LVEND.LE.0. OR .MVEND.LE.0. OR .NI
C     XEND.LE.
C     1 0. OR .NEWRHS.LE.0. OR .NRMAX.LE.0. OR .MAXTAP.LE.0.
C     2  OR .MAXELT.LE.0. OR .(NTIREX.NE.0. AND .NTIREX.NE.1)
C     ) GO TO 130
C     LVMAX=0
C     NIZZ=0
C     MAXNIC=0
C     MAXPA=0
C     NVABZ=0
C     LCUREQ=0
C     DO 4 I=1,MVEND
C     MVABL(I)=0
4    CONTINUE
C     DO 10 NELEM=1,1000000
C
C     THIS LOOP READS IN ELEMENT OR SUBASSEMBLY INFORMA-
C     TION AND THE ELEMENT OR SUBASSEMBLY DEGREE OF FREEDOM
C     NUMBERS IN THE STRUCTURE SYSTEM.

```



```

C
5003 READ (5,900) KUREL,NRD,KE,KL1,NRE,KL2,LFORCE(NELEM)
C
C     THE VARIABLES IN THIS READ STATEMENT ARE DEFINED
C     AS FOLLOWS:
C     KUREL = NUMBER OF ACTIVE UNRELEASED DEGREES OF
C     FREEDOM (DOF) IN THE ELEMENT/SUBASSEMBLY.
C     NRD = NUMBER OF ACTIVE, RELEASED DOF IN THE ELE-
C     MENT. NRD = 0 FOR ALL SUBASSEMBLIES. RELEASED DE-
C     GREES OF FREEDOM IN A SUBASSEMBLY ARE TREATED IN
C     SUBROUTINE STIGEN.
C     KE = NUMBER OF ELEMENTS IN SUBASSEMBLY. A SINGLE
C     ELEMENT CAN BE TREATED AS A SUBASSEMBLY BY TAKING
C     KE = 1 OR KE CAN BE SET = 0 AND THE SUBASSEMBLY
C     FACILITY BYPASSED, WHICH REDUCES THE AMOUNT OF IN-
C     PUT AND ALLOWS THE PROGRAM TO OPERATE MORE EFFIC-
C     IENTLY.
C     KL1 = A VARIABLE WHICH INDICATES WHETHER OR NOT A
C     SUBASSEMBLY IS ONE OF A NUMBER OF IDENTICAL SUB-
C     ASSEMBLIES WHICH APPEAR IN THE PROGRAM. IF THIS IS
C     THE FIRST APPEARANCE OF A SUBASSEMBLY, KL1 IS POS-
C     ITIVE; FOR ALL OTHER SUBASSEMBLIES WITH IDENTICAL
C     STIFFNESS MATRICES IT IS NEGATIVE. THE SUBASSEM-
C     BLIES SHOULD BE NUMBERED CONSECUTIVELY FROM ONE IN
C     THE ORDER IN WHICH EACH FIRST APPEARS. THE FIRST
C     APPEARANCE OF A SUBASSEMBLY DETERMINES KL1 FOR IT.
C     IF KE = 0, THEN KL1 = 0.
C     NRE = NUMBER OF SUPPORTED DEGREES OF FREEDOM IN
C     ELEMENT/SUBASSEMBLY.
C     KL2 = NUMBER OF LOADED DEGREES OF FREEDOM IN SUB-
C     ELEMENT/SUBASSEMBLY.
C     KL2 = NUMBER OF LOADED DEGREES OF FREEDOM IN SUB-
C     ASSEMBLY. IF KE = 0, KL2 = 0. IF KE IS NOT EQUAL
C     0, THEN LOAD (SEE INPUT IN SUBROUTINE ELMAK) IS
C     ZERO FOR ALL MEMBERS IN THE SUBASSEMBLY.
C     LFORCE(NELEM) = 0 IF FORCES ARE NOT DESIRED FOR
C     THE ELEMENT/SUBASSEMBLY.
C     1 IF FORCES SHOULD BE CALCULATED.
C     IF THE FORCES ARE REQUIRED FOR A SUBASSEMBLY, THEN
C     LFORCE(NELEM) MUST BE 1 FOR THE FIRST APPEARANCE
C     OF THAT SUBASSEMBLY, I. E. WHEN KL1 IS POSITIVE.
C
C     JWHERE=2
C     IF(KUREL.LT.0) GO TO 130
C     IF(KUREL.EQ.0) GO TO 12
5004 READ (5,900) (LVABL(I), I = 1,KUREL)
C
C     THE VECTOR LVABL WHICH IS READ IN BY THIS STMT IS
C     A LIST OF THE ACTIVE, UNRELEASED DEGREES OF FREEDOM IN
C     THE STRUCTURE NUMBERING SYSTEM.
C     AFTER THESE TWO READ STATEMENTS HAVE BEEN READ FOR
C     EACH ELEMENT, A CARD WITH KUREL = 0 SHOULD BE PLACED
C     NEXT IN THE INPUT DECK. THIS KEYS THE PROGRAM TO GO ON
C     TO THE NEXT PART OF THE PROGRAM.

```

C

```

IF(KUREL.LE.LVMAX) GO TO 6
LVMAX=KUREL
JWHERE=3
IF(LVMAX.GT.LVEND) GO TO 130
6 JWHERE=4
JWHERE=5
IF(NIZZ+KUREL+NELEM.GT.NIXEND) GO TO 130
DO 8 I=1,KUREL
NIC=LVABL(I)
JWHERE=6
IF(NIC.LE.0) GO TO 130
NIZZ=NIZZ+1
NIX(NIZZ)=-NIC
J=I
7 J=J+1
IF(J.GT.KUREL) GO TO 8
IF(LVABL(J).EQ.NIC) WRITE(6,834) JWHERE,NIC
GO TO 7
8 CONTINUE
I=KUREL+1
IJKL= 6*NELEM
NIX(NIXEND+5-IJKL) = KL2
NIX(NIXEND+6-IJKL) = NRE
NIX(NIXEND+4-IJKL) = NIZZ
NIX(NIXEND+3-IJKL) = NRD
NIX(NIXEND+2-IJKL) = KE
NIX(NIXEND+1-IJKL) = KL1
10 CCNTINUE
12 NELEMZ=NELEM-1
N1=1
DO 26 NELEM=1,NELEMZ

```

C

C

C

C

C

C

C

C

C

C

C

C

C

C

```

IJKL = 6*NELEM
LPREQ =LCUREQ
LCUREQ=NVABZ
NZ = NIX(NIXEND + 4 - IJKL)
KUREL = NZ-N1+1
NRD = NIX(NIXEND + 3-IJKL)
KE = NIX(NIXEND+2-IJKL)
KL1 = NIX(NIXEND+1-IJKL)
KL2 = NIX(NIXEND+5-IJKL)
NRE = NIX(NIXEND+6-IJKL)
DO 22 NEW=N1,NZ

```

```

NIC=NIX(NEW)
LDES=NIC
IF(NIC.GT.0) GO TO 20
IF(MAXNIC+NIC.LT.0) MAXNIC=-NIC
NCOR16=MAXPA
IF(NCOR16.EQ.0) NCOR16=1
DO 14 LDES=1,NCOR16
IF(MVABL(LDES).EQ.0) GO TO 16
14 CONTINUE
LDES=NCOR16+1
16 MVABL(LDES)=NIC
IF(LDES.GT.MAXPA) MAXPA=LDES
JWHERE=7
IF(MAXPA.GT.MVEND) GO TO 130
KOUNT=1000
DO 18 LAS=NEW,NIZZ
IF(NIX(LAS).NE.NIC) GO TO 18
NIX(LAS)=LDES
KOUNT=KOUNT+1000
LAST=LAS
18 CONTINUE
LAS=NIZZ+1
NIX(LAS)=LDES+1000
LDES=LDES+KOUNT
NIX(NEW)=LDES
20 LDEST(NEW-N1+1)=LDES
22 CONTINUE
NEW=NZ+1
N1=NEW
DO 24 KL=1,KUREL
CALL CODEST
NIC=-MVABL(LDES)
LVABL(KL)=NIC
IF(NSTRES.NE.0. AND .NSTRES.NE.1) GO TO 24
MVABL(LDES)=0
NVABZ=NVABZ+1
24 CONTINUE
IF (LFORCE(NELEM).NE.0) WRITE(3) KUREL,NRD,KE,KL1,(LVA
C  BL(I),I=1,
$  KUREL)
KL=KUREL+1
KK = 2
IF (KE.EQ.0) GO TO 306
IF (KL1.GE.0) GO TO 305
KL1 = -KL1
LZ = (KUREL+1+NEWRHS*2)*KUREL/2
NPMAX = KUREL*(KUREL+1)/2
DO 1002 I = 1,NPMAX
1002 EL(I) = STORE(LOC(KL1)-1+I)
NPM = NPMAX + 1
DO 1008 I = NPM , LZ
1008 EL(I) = 0.0
GO TO 320
305 KK = 3

```

```

      CALL STIGEN
      320 IF(KL2.EQ.0) GO TO 319
      5005 READ (5,600) (JJ(I),P(I), I = 1,KL2)
C
C      THIS STATEMENT SERVES TO READ IN THE LOADS ON A
C      SUBASSEMBLY. IT IS USED ONLY IF KL2 IS NON-ZERO. THE
C      ELEMENTS OF THE VECTOR JJ(I) INDICATE WHICH ELEMENT IN
C      THE LOAD VECTOR IS NON-ZERO. THE LOAD VECTOR CONTAINS
C      ONLY ACTIVE UNRELEASED DEGREES OF FREEDOM. THE ELEMENTS
C      OF THE VECTOR P(I) ARE THE VALUE OF THE LOAD WITH COR-
C      RECT SIGN.
C
      600 FORMAT (8(I3,F6.0))
      NPMAX = (KUREL+1)*KUREL/2
      LZ = NPMAX + KUREL*NEWRHS
      DO 1005 I = 1,KL2
      1005 EL(JJ(I)+NPMAX) = EL(JJ(I)+NPMAX) + P(I)
      319 IF (NRE.EQ.0) GO TO 304
      5006 READ (5,900) (NR(I), I = 1,NRE)
C
C      THIS STATEMENT READS IN WHICH OF THE DEGREES OF
C      FREEDOM, IN THE SUBASSEMBLY NUMBERING SYSTEM, ARE SUP-
C      PORTED. THE ELEMENTS OF THE VECTOR NR(I) ARE THE SUP-
C      PORTED DEGREES OF FREEDOM IN THE SUBASSEMBLY NUMBERING
C      SYSTEM. IF TWO OR MORE SUBASSEMBLIES HAVE A SUPPORTED
C      DEGREE OF FREEDOM IN COMMON, IT SHOULD BE INDICATED AS
C      SUPPORTED IN ONLY ONE OF THE ELEMENTS OR SUBASSEMBLIES.
C
      DO 1007 I = 1,NRE
      NP = NR(I)+(NR(I)*(NR(I)-1))/2
      1007 EL(NP) = EL(NP) + 1.00+20
      304 KK = 4
      306 CONTINUE
      CALL ELMAX
      26 CONTINUE
      NELEM=NELEMZ+1
      REWIND 1
      34 JWHERE=8
      NRHS=NEWRHS
      IF(NRHS.GT.NRMAX) GO TO 130
C
C      THE PORTION OF THE PROGRAM BETWEEN HERE AND STATE-
C      MENT 38 ESTABLISHES THE STORAGE REQUIREMENTS IN THE
C      VARIOUS VECTORS REQUIRED IN THE ELIMINATION PROCESS.
C      DETAILED DOCUMENTATION IS AVAILABLE IN REF. 52.
C
      NELZ=NFUNC(0,LVMAX+1)*INITL+LVMAX*NRHS
      IF(NELZ.GT.MAXELT) NELZ=MAXELT
      NPAR=NFUNC(0,MAXPA+1)*INITL+NELZ
      IF(INITL.EQ.0) GO TO 36
      NPAZ=(LVMAX+MAXPA)*NRMAX
      IF(NTIREX.NE.0) NPAZ=(MAXNIC+MAXPA)*NRMAX
      N=NPAR+MAXPA*(NRHS+1)
      IF(N.GT.NPAZ) NPAZ=N

```

```

NBAXO=NPAZ+1
IBA=NBAXO
NBAXZ=NBAXO+MAXTAP
IF(NBAXZ.GT.NELPAZ) NBAXZ=NELPAZ
NBUFFA=NBAXZ-NBAXO
JWHERE=9
IF(NBUFFA.LT.MAXPA+NRMAX+3) GO TO 130
NRUNO=NPAZ-NRMAX*MAXPA
36 NCOR1=NBAXO+INITL*NBUFFA
DO 38 I=1,NCOR1
ELPA(I)=0.0
38 CONTINUE
I=NCOR1+1
KURPA=0
DO 92 NELEM=1,NELEMZ

```

```

C
C      THIS LOOP ASSEMBLES THE ELEMENTS AND DOES THE
C      ELIMINATIONS. IT GOES THROUGH EACH ELEMENT ONE BY
C      ONE, ADDING THE STIFFNESS CONTRIBUTION OF EACH TO THE
C      EQUATIONS AND THEN ELIMINATING THOSE VARIABLES WHICH DO
C      NOT APPEAR IN ANY OF THE ELEMENTS YET TO BE ASSEMBLED.
C      DETAILED DOCUMENTATION OF THIS PORTION OF THE PROGRAM
C      IS AVAILABLE IN REF. 52.
C

```

```

IF(INITL.EQ.0) BACKSPACE 1
READ(1) KUREL,LPREQ,(LVABL(I),LDEST(I),I=1,KUREL),
1  LZ,(ELPA(I),I=1,LZ)
IF(INITL.EQ.0) BACKSPACE 1
WRITE(2) KUREL,LPREQ,(LVABL(I),LDEST(I),I=1,KUREL),
1  IBA,(ELPA(I),I=NBAXO,IBA)
JWHERE=10
IF(LZ.GT.NELZ. OR .LZ.LE.0) GO TO 130
IBA=NBAXO
NEW=1
L=0
DO 40 KL=1,KUREL
CALL CODEST
MVABL(LDES)=LVABL(KL)
LVABL(KL)=LDES
IF(LDES.GT.KURPA) KURPA=LDES
40 CONTINUE
KL=KUREL+1
NCOR2=2-INITL
DO 66 LHSRHS=NCOR2,2
LHS=2-LHSRHS
IRHS=1-LHS
NCOR3=LHS*KUREL+IRHS*NRHS
DO 64 KL=1,NCOR3
GO TO (42,44),LHSRHS
42 KG=LVABL(KL)
MGO=NFUNC(0,KG)+NELZ
GO TO 46
44 MGO=(KL-1)*MAXPA+NPAP
46 NCOR4=LHS*KL+IRHS*KUREL

```

```

DO 62 IL=1,NCOR4
IG=LVABL(IL)
L=L+1
48 CE=ELPA(L)
GO TO (50,56),LHSRHS
50 IF(KG-IG) 52,54,56
52 MG=NFUNC(KG,IG)+NELZ
GO TO 58
54 IF(KL.NE.IL) CE=CE+CE
56 MG=MGO+IG
58 IF(L.LE.LZ) GO TO 60
IF(INITL.EQ.0) BACKSPACE 1
READ(1) LZ,(ELPA(I),I=1,LZ)
IF(INITL.EQ.0) BACKSPACE 1
JWHERE=11
IF(LZ.GT.NELZ. OR .LZ.LE.0) GO TO 130
L=1
GO TO 48
60 ELPA(MG)=ELPA(MG)+CE
62 CONTINUE
IL=NCOR4+1
64 CONTINUE
KL=NCCR3+1
66 CONTINUE
LHSRHS=3
JWHERE=12
IF(L.NE.LZ) GO TO 130
DO 90 KL=1,KUREL
CALL CODEST
IF(NSTRES.NE.0. AND .NSTRES.NE.1) GO TO 90
68 NDEQN=IBA+KURPA+NRMAX+3
IF(NDEQN.LE.NBAXZ. AND .NEW.EQ.0) GO TO 70
IF(NEW.EQ.0) WRITE(2) IBA,(ELPA(I),I=NBAXO,IBA)
IBA=NBAXO
NEW=0
IF(INITL.NE.0) GO TO 68
BACKSPACE 1
READ(1) NBZ,(ELPA(I),I=NBAXO,NBZ)
BACKSPACE 1
GO TO 68
70 IBDIAG=IBA+LDES
NDIAG=IBDIAG
IF(INITL.NE.0) NDIAG=NFUNC(0,LDES+1)+NELZ
PIVOT=ELPA(NDIAG)
ELPA(NDIAG)=0.0
JWHERE=13
IF(PIVOT.EQ.0) GO TO 130
MGZ=NELZ
JGZ=KURPA
IBO=IBA
IF(INITL.EQ.0) IBA=IBA+KURPA
NCOR5=2-INITL
DO 86 LHSRHS=NCOR5,2
IF(LHSRHS.EQ.2) JGZ=NRHS

```

```

DO 84 JG=1,JGZ
  IBA=IBA+1
  GO TO (72,76),LHSRHS
72 MGO=MGZ
  MGZ=MGO+JG
  IF(LDES.GT.JG) GO TO 74
  MG=MGO+LDES
  GO TO 78
74 MG=NFUNC(JG,LDES)+NELZ
  GO TO 78
76 MGO=(JG-1)*MAXPA+NPAR
  MG=MGO+LDES
  MGZ=MGO+KURPA
78 NDELT=IBC-MGO
  CONST=ELPA(MG)
  ELPA(IBA)=CONST
  IF(CONST.EQ.0) GO TO 84
  CONST=CONST/PIVOT
  ELPA(MG)=0.0
  IF(INITL.NE.LHSRHS) GO TO 80
  MG=NPAR+NRHS*MAXPA+JG
  ELPA(MG)=ELPA(MG)+ELPA(MGZ)**2
80 NCOR6=MGO+1
  DO 82 I=NCOR6,MGZ
  ELPA(I)=ELPA(I)-CONST*ELPA(I+NDELT)
82 CONTINUE
  I=MGZ+1
84 CONTINUE
  JG=JGZ+1
86 CONTINUE
  LHSRHS=3
  ELPA(IBDIAG)=PIVOT
  IBA=NDEQN
  ELPA(IBA)=KURPA
  ELPA(IBA-1)=LDES
  ELPA(IBA-2)=MVABL(LDES)
  IF(INITL.EQ.0) GO TO 88
  MG=NPAR+NRHS*MAXPA+LDES
  CRIT = DSQRT(ELPA(MG))/DABS(PIVOT)
  ELPA(MG)=0.0
  JWHERE=14
  IF(CRIT.GT.1.0E8) GO TO 130
  JWHERE = 15
  IF(CRIT.GT.1.0E4. OR .PIVOT.LT.0.)
1  WRITE(6,834) JWHERE,NIC,CRIT,PIVOT
88 MVABL(LDES)=0
  IF(MVABL(KURPA).NE.0) GO TO 90
  KURPA=KURPA-1
  IF(KURPA.NE.0) GO TO 88
90 CONTINUE
  KL=KUREL+1
92 CONTINUE

```

C  
C

THE PORTION OF THE PROGRAM BETWEEN HERE AND STMT

C 112 DOES THE BACKSUBSTITUTION INTO THE UPPER TRIANGU-  
 C LAR MATRIX AND OBTAINS THE DISPLACEMENTS. THE DOCUMEN-  
 C TATION FOR THIS PORTION OF THE PROGRAM CAN BE FOUND IN  
 C REF. 52.  
 C

```

    NELEM=NELEMZ+1
    NCOR7=NELZ*NTIREX
    IF(NCOR7.EQ.0) NCOR7=1
    DO 94 I=1,NCOR7
    ELPA(I)=0.0
  94 CONTINUE
    I=NCCR7+1
    IF(INITL.NE.0) REWIND 1
    INITL=0
  
```

```

5007 READ (5,900) NEWRHS, NRAT, (NRA(I), I = 1,NRAT)
  
```

C THE VARIABLES IN THIS READ STMT ARE DEFINED AS  
 C FOLLOWS:  
 C NEWRHS = 0 IF NO NEW PROBLEM FOLLOWS.  
 C -1 IF ANOTHER PROBLEM FOLLOWS.  
 C NRAT = NUMBER OF SUPPORTED DEGREES OF FREEDOM PLUS  
 C ONE.  
 C NRA(I) = THE NUMBERS OF THE SUPPORTED DEGREES OF  
 C FREEDOM IN THE STRUCTURAL SYSTEM. THE INDEX I RUNS  
 C FROM 1 TO NRAT, SO ONE MORE NUMBER THAN THE NUM-  
 C BER OF REACTIONS MUST BE SUPPLIED. THE LAST ELE-  
 C MENT OF VECTOR NRA(I) CAN BE ANY INTEGER.  
 C

```

    NBZ=IBA
    NEQ=NVABZ
    LPREQ=LCUREQ
    NELEM=NELEMZ
  100 IF(IBA.NE.NBAXO) GO TO 102
    BACKSPACE 2
    READ(2) NBZ, (ELPA(I), I=NBAXO,NBZ)
    BACKSPACE 2
    IBA=NBZ
  102 KURPA=ELPA(IBA)
    LDES=ELPA(IBA-1)
    NIC=ELPA(IBA-2)
    IBAR=IBA-NRMAX-3
    IBA=IBAR-KURPA
    IBDIAG=IBA+LDES
    PIVOT=ELPA(IBDIAG)
    ELPA(IBDIAG)=0.0
    DO 106 J=1,NRHS
    MGO=NRUNO+(J-1)*MAXPA
    MGZ=MGO+KURPA
    CONST=ELPA(IBAR+J)
    NDELT=IBA-MGO
    NCOR8=MGO+1
    DO 104 I=NCOR8,MGZ
    CONST=CONST-ELPA(I)*ELPA(I+NDELT)
  104 CONTINUE
  
```



```

I=MGZ+1
ANSWER=CONST/PIVOT
ELPA(MGO+LDES)=ANSWER
IF(NTIREX.NE.0) ELPA(NIC)=ANSWER
NIC=NIC+MAXNIC
106 CONTINUE
J=NRHS+1
ELPA(IBDIAG)=PIVOT
IF(IBA.EQ.NBAXO. AND .NEWRHS.GT.0)
1  WRITE(1) NBZ,(ELPA(I),I=NBAXO,NBZ)
NEQ=NEQ-1
108 IF(NEQ.NE.LPREQ) GO TO 100
BACKSPACE 2
READ(2) KUREL,LPREQ,(LVABL(I),LDEST(I),I=1,KUREL),
1  NBZ,(ELPA(I),I=NBAXO,NBZ)
BACKSPACE 2
IBA=NBZ
IF(NTIREX.NE.0) GO TO 114
DO 112 KL=1,KUREL
CALL CODEST
NRUN=NRUNQ+LDES
NCOR9=NRHS*KUREL
DO 110 L=KL,NCOR9,KUREL
ELPA(L)=ELPA(NRUN)
NRUN=NRUN+MAXPA
110 CONTINUE
L=NCCR9+1
112 CONTINUE

```

```

C
C      THE BALANCE OF THE MAIN ROUTINE IS USED TO PRINT
C      OUT THE DISPLACEMENTS AND FORCES.
C

```

```

      KL=KUREL+1
      WRITE(6,828) NELEM
828  FORMAT(/17H ANSWERS, ELEMENT,I4/)
      WRITE(6,810) KUREL,LPREQ,(LVABL(I),I=1,KUREL)
      NCOR10=KUREL*NRHS
      WRITE(6,800)(ELPA(I),I=1,NCOR10)

```

```

C
C      THESE THREE WRITE STATEMENTS PRINT OUT THE RESULTS
C      IF THE OPTION TO GET OUTPUT BY ELEMENTS HAS BEEN ELEC-
C      TED, I. E. NTIREX = 0.
C

```

```

114 CALL ELMK
DO 116 KL=1,KUREL
CALL CODEST
IF(NSTRES.LE.0) GO TO 116
NIC=LVABL(KL)
116 CONTINUE
KL=KUREL+1
NELEM=NELEM-1
IF(NELEM.NE.0) GO TO 108
NCOR11=MAXNIC*NRHS
NRATT = NRAT -1

```

```

      DO 400 I = 1, NRATT
400  EL(I) = ELPA(NRA(I))*(-1.0D+20)
      WRITE (6,840) (I,ELPA(I),I=1,NCOR11)
840  FORMAT (5(4H DOF,I4,2X,D14.6))
      WRITE (6,843)
843  FORMAT (1H0)
      WRITE (6,841) (NRA(I),EL(I),I=1, NRATT)

```

C  
C  
C  
C  
C  
C  
C

THE ABOVE WRITE STATEMENTS PRINT OUT THE DISPLACEMENTS AND REACTIONS IF NTIREX IS EQUAL TO ONE. THE DISPLACEMENT OUTPUT CONSISTS OF THE DOF NUMBER AND THE ASSOCIATED DISPLACEMENT. THE REACTION OUTPUT GIVES THE DEGREE OF FREEDOM NUMBER AND THE VALUE OF THE REACTION.

```

841  FORMAT (6X,32HREACTION ASSOCIATED WITH DOF NO.,I5,3H I
C    S,D20.8)
      IF (NFORCE.EQ.0) GO TO 1050
      REWIND 3
1051 CALL FORCE
1050 CONTINUE
      IF(NEWRHS) 2,140,34
130  WRITE(6,832)
832  FORMAT(/6H ERROR)
      WRITE(6,834) JWHERE,NIC,CRIT,PIVOT,LZ,NELZ,NELEM,NRHS,
1    NBUFFA,LVMAX,NIZZ,NELPAZ,LVEND,MVEND,NIXEND

```

C  
C  
C  
C  
C  
C  
C

THESE TWO WRITE STATEMENTS PROVIDE NOTICE OF ERRORS OCCURRING IN THE PROGRAM AND PROVIDE SOME DATA TO HELP DETERMINE THE CAUSE OF THE ERROR. REF. 52 PROVIDES MORE INFORMATION ON THE DIAGNOSTICS.

```

      A=0.0
      A=1.0/A
140  STOP
800  FORMAT(5X,8D15.5)
834  FORMAT(/9H JWHERE =,I3,5X,5HNIC =,I4,5X,6HCRIT =,E9.2,
C    3X,
1    7HPIVOT =,E12.4,3X,4HLZ =,I5,11X,6HNELZ =,I5/
2    8H NELEM =,I4,5X,6HNRHS =,I3,5X,8HNBUFFA =,I6,4X,
3    7HLVMAX =,I5,10X,6HNIZZ =,I5,9X,8HNELPAZ =,I5/
4    8H LVEND =,I4,5X,7HMVEND =,I4,3X,8HNIXEND =,I6)
900  FORMAT(16I5)
      END

```

## SUBROUTINE CODEST

C  
C  
C  
C  
C  
C

SUBROUTINE CODEST HAS NO ARGUMENTS. ALL NECESSARY  
TRANSFER OF INFORMATION IS ACCOMPLISHED BY MEANS OF  
COMMON BLOCKS. SUBROUTINE CODEST IS USED TO KEEP TRACK  
OF VARIABLES IN THE ELIMINATION ROUTINE. SEE REF. 52.

```

IMPLICIT REAL*8(A-H,O-Z)
COMMON /BLK10/ ELPA(12000),ELCOR(3,4),EL(900),BMK(12,1
C 2),
1 CLK(12,12),PLK(12,12)
COMMON /BLK13/ FLK(12,12),PLKR(12,12)
COMMON /BLK11/ MVABL(80),LVABL(80),LND(80),LDEST(80),L
C RD(12)
COMMON /BLK12/ INITL,NTIREX,NEWRHS,NELEM,NELEMZ,KUREL,
C LPREQ,
1 LZ,NELZ,NBAXO,NBZ,KL,LDES,NSTRES,KK
COMMON /BLK14/ LOAD
COMMON /BLK15/ NTYPE,NRD
LDES=LDEST(KL)
DO 2 NSTRES=1,1000000
IF(LDES.LT.1000) GO TO 4
LDES=LDES-1000
2 CONTINUE
4 NSTRES=NSTRES-2
RETURN
END

```



```
K(3,1) = T*((-A*D/3.)+G/(6.*D))
K(4,2) = -T*((-B/(6.*D))+(G*D/3.))
K(5,3) = T*((A*D/6.)-(G/(3.*D)))
K(6,4) = T*((-B/(3.*D))+(G*D/6.))
K(7,5) = K(3,1)
K(8,6) = K(4,2)
K(5,1) = -K(1,1)/2.
K(6,2) = -K(2,2)/2.
K(7,3) = K(5,1)
K(8,4) = K(6,2)
K(7,1) = K(5,3)
K(8,2) = K(6,4)
DO 101 I = 2,8
DO 102 J = 1,7
IF (I.LE.J) GO TO 101
K(J,I) = K(I,J)
102 CONTINUE
101 CONTINUE
DO 103 I = 1,8
DO 104 J = 1,8
PLK(I,J) = K(I,J)
104 CONTINUE
103 CCNTINUE
RETURN
END
```



END

```

SUBROUTINE COLUM(ALEN,ZI,YI,AX,YM,CLK,GI,GM)

```

```

C
C
C     SUBROUTINE COLUM  GENERATES THE STIFFNESS MATRIX
C     FOR A COLUMN ELEMENT, WHICH IS HERE TAKEN TO BE A VER-
C     TICAL MEMBER WITH THREE DISPLACEMENTS AND TWO ROTATIONS
C     AS SHOWN IN FIGURE A2. TWISTING OF THE SECTION IS NOT
C     A DEGREE OF FREEDOM IN THE STIFFNESS MATRIX GENERATED
C     HERE. THE ARGUMENTS OF THE SUB ROUTINE ARE:
C     ALEN = LENGTH OF THE MEMBER.
C     ZI = THE MCMENT OF INERTIA ABOUT THE AXIS OF BEN-
C     DING ASSOCIATED WITH DEGREES OF FREEDOM 5 AND 10.
C     YI = THE MCMENT OF INERTIA ABOUT THE AXIS OF BEN-
C     DING ASSOCIATED WITH DEGREES OF FREEDOM 3 AND 8.
C     AX = CROSS-SECTIONAL AREA OF THE MEMBER.
C     YM = ELASTIC MODULUS OF THE COLUMN MATERIAL.
C     CLK = COLUMN STIFFNESS MATRIX.
C     GI = AREA SHAPE FACTOR TO BE USED IF SHEAR DEFOR-
C     MATIONS ARE TO BE ACCOUNTED FOR.
C     GM = SHEAR MODULUS OF THE COLUMN MATERIAL.

```

```

C
C     IMPLICIT REAL*8(A-H,O-Z)
C     DIMENSION CLK(12,12)
C     DO 100 I = 1,10
C     DO 101 J = 1,10
C     CLK(I,J) = 0.0
101 CONTINUE
100 CONTINUE
C     GY = 0.0
C     GZ = 0.0
C     IF (GM.EQ.0.0) GO TO 104
C     GZ = 6.*GI*YM*ZI/(GM*AX*ALEN**2)
C     GY = 6.*GI*YM*YI/(GM*AX*ALEN**2)
104 CONTINUE
C     SZ = YM*ZI/(1. + 2.*GZ)
C     SY = YM*YI/(1. + 2.*GY)
C     CLK(1,1) = 12.*SZ/ALEN**3
C     CLK(1,5) = 6.*SZ/ALEN**2
C     CLK(1,6) = -CLK(1,1)
C     CLK(1,10) = CLK(1,5)
C     CLK(2,2) = 12.*SY/ALEN**3
C     CLK(2,3) = 6.*SY/ALEN**2
C     CLK(2,7) = -CLK(2,2)
C     CLK(2,8) = CLK(2,3)
C     CLK(3,3) = (4.*SY/ALEN)*(1. + (GY/2.))
C     CLK(3,7) = -CLK(2,3)
C     CLK(3,8) = (2.*SY/ALEN)*(1. - GY)
C     CLK(4,4) = AX*YM/ALEN
C     CLK(4,9) = -CLK(4,4)
C     CLK(5,5) = (4.*SZ/ALEN)*(1. + (GZ/2.))
C     CLK(5,6) = -6.*SZ/ALEN**2
C     CLK(5,10) = (2.*SZ/ALEN)*(1. - GZ)
C     DO 103 I = 1,5
C     CLK(I+5,I+5) = CLK(I,I)
103 CONTINUE

```



```
CLK(6,10) = CLK(5,6)
CLK(7,8) = -CLK(2,3)
DO 105 I = 2,10
DO 105 J = 1,9
IF (I.LE.J) GO TO 105
CLK(I,J) = CLK(J,I)
105 CONTINUE
RETURN
END
```

```

SUBROUTINE MATMUL(AR1,AR2,NR1,NC1,NR2,NC2,      MM,CONG)
C
C      SUBROUTINE MATMUL IS USED TO MULTIPLY TWO MATRICES
C      AND TO PERFORM A CONGRUENT TRANSFORMATION IF DESIRED.
C      THE MAXIMUM SIZE MATRIX THAT CAN BE DEALT WITH IS A 12
C      X 12. THE ARGUMENTS OF THIS SUBROUTINE ARE:
C      AR1 = THE PREMULIPLYING MATRIX.
C      AR2 = THE POST MULTIPLYING MATRIX. IF A CONGRUENT
C      TRANSFORMATION IS DESIRED, AR1 SHOULD BE THE MID-
C      DLE MATRIX AND AR2 THE POSTMULTIPLYING MATRIX IN
C      THE TRANSFORMATION.
C      NR1 = NUMBER OF ROWS IN AR1
C      NC1 = NUMBER OF COLUMNS IN AR1
C      NR2 = NUMBER OF ROWS IN AR2
C      NC2 = NUMBER OF COLUMNS IN AR2
C      MM = 1 IF A CONGRUENT TRANSFORMATION IS REQUIRED.
C      ANY OTHER INTEGER WILL RESULT SIMPLY IN AR1*AR2.
C      CONG = MATRIX WHICH CONTAINS THE RESULT OF A CON-
C      GRUENT TRANSFORMATION.
C      TO USE THE SUBROUTINE, THE MATRICES AR1, AR2 AND
C      CONG SHOULD BE DIMENSIONED 12 X 12. THE RESULT OF A
C      MULTIPLICATION OF TWO MATRICES IS RETURNED TO THE CALL-
C      ING ROUTINE VIA COMMON BLOCK 50 AND THE MATRIX ARP.
C
      IMPLICIT REAL*8(A-H,O-Z)
      DIMENSION AR1(12,12),AR2(12,12),CONG(12,12)
      COMMON /BLK50/ ARP(12,12)
      DO 100 I = 1,12
      DO 100 J = 1,12
      CONG(I,J) = 0.0
100  ARP(I,J) = 0.0
      DO 101 I = 1,NR1
      DO 101 J = 1,NC2
      DO 101 K = 1,NC1
101  ARP(I,J) = AR1(I,K)*AR2(K,J) + ARP(I,J)
      IF (MM.NE.1) RETURN
      DO 102 I = 1,NC2
      DO 102 J = 1,NC2
      DO 102 K = 1,NR2
102  CONG(I,J) = AR2(K,I)*ARP(K,J) + CONG(I,J)
      RETURN
      END

```



C RIGID FLOORS  
 C 5 FOR PLATE ELEMENT IN STRUCTURE WITH  
 C RIGID FLOORS  
 C 6 FOR DIAGONAL ELEMENT  
 C 7 FOR DIAGONAL ELEMENT IN STRUCTURE WITH  
 C RIGID FLOORS  
 C 8 THIS CAN BE USED TO READ IN DIRECTLY THE  
 C STIFFNESS MATRIX FOR AN ELEMENT WITH 12  
 C DOF  
 C 9 SAME AS 8 EXCEPT 2 DOF ELEMENT  
 C LIKE = A VARIABLE WHICH INDICATES WHETHER OR NOT  
 C THE STIFFNESS MATRIX FOR THIS ELEMENT SHOULD BE  
 C STORED FOR LATER USE, IS ALREADY STORED, OR IS NOT  
 C NEEDED AGAIN. IF LIKE IS ZERO, THE ELEMENT STIFF-  
 C NESS NEED NOT BE STORED. IF LIKE IS POSITIVE, THIS  
 C IS THE FIRST APPEARANCE OF THE ELEMENT AND THERE  
 C ARE OTHERS TO FOLLOW WHICH HAVE IDENTICAL STIFF-  
 C NESSES, SO THE STIFFNESS MATRIX SHOULD BE STORED.  
 C IF LIKE IS NEGATIVE, THE REQUIRED STIFFNESS MATRIX  
 C IS IN STORAGE AND NEED NOT BE GENERATED. IF LIKE  
 C IS NEGATIVE, READ STATEMENTS 301, 302, 303, AND  
 C 304 ARE BYPASSED, SO NO DATA IS SUPPLIED FOR THEM.  
 C LOAD = THE NUMBER OF LOADED DEGREES OF FREEDOM IN  
 C THE ELEMENT. IF THE ELEMENT IS PART OF A SUBASSEM-  
 C BLY, AND KL2 IS NON-ZERO, THEN LOAD SHOULD BE  
 C ZERO.  
 C LND = VECTOR OF ACTIVE DEGREES OF FREEDOM, BOTH  
 C RELEASED AND UNRELEASED, IN THE ELEMENT NUMBERING  
 C SYSTEM. THE ELEMENT NUMBERING SYSTEMS FOR TYPE 1  
 C THRU 7 ELEMENTS ARE SHOWN IN FIGS. A1, A2, B1, AND  
 C A3 - A6 RESPECTIVELY.

C IF (LFORCE(NELEM).NE.0) WRITE (3) NTYPE,LIKE,(LND(I),I  
 C =1, KKUREL)  
 604 FORMAT (16I5)  
 IF (NTYPE.EQ.8) GO TO 400  
 IF (NTYPE.EQ.9) GO TO 404  
 IF (LIKE.LT.0) GO TO 720  
 GO TO (301,302,303,302,303,304,304), NTYPE  
 304 READ (5,610) HL,VL,ZI,AX,YM,GI,GM

C THIS READ STATEMENT READS IN THE GEOMETRIC AND  
 C ELASTIC PROPERTIES OF DIAGONAL MEMBERS (TYPE 6 AND 7).  
 C THE VARIABLES ARE:  
 C HL = LENGTH OF THE HORIZONTAL PROJECTION OF THE  
 C MEMBER. IT MUST HAVE THE PROPER SIGN. FIGURE A3  
 C SHOWS THE PROPER SIGNS FOR VARIOUS ORIENTATIONS  
 C OF THE MEMBER.  
 C VL = LENGTH OF THE VERTICAL PROJECTION OF THE MEM-  
 C BER. VL SHOULD ALWAYS BE POSITIVE.  
 C ZI = MCMENT OF INERTIA OF THE MEMBER  
 C AX = CROSS-SECTIONAL AREA OF THE MEMBER  
 C YM = ELASTIC MODULUS OF THE MEMBER MATERIAL.  
 C GI = AREA SHAPE FACTOR TO BE USED IF SHEAR DEFOR-

```

C           MATIONS ARE TO BE ACCOUNTED FOR.
C           GM = SHEAR MODULUS. IF SHEAR DEFORMATIONS ARE TO
C           BE IGNORED, GM = 0.0.
C
610 FORMAT (4F10.4,F15.5,F10.4,F15.5)
      ALEN = DSQRT((HL**2)+(VL**2))
      GC TO 641
301 READ (5,601) ALEN,ZI,AX,YM,GI,GM
C
C           THIS STATEMENT READS IN THE GEOMETRIC AND ELASTIC
C           PROPERTIES FOR A BEAM ELEMENT (TYPE 1). THE VARIABLES
C           READ IN ARE:
C           ALEN = BEAM LENGTH
C           THE BALANCE OF THE VARIABLES ARE DEFINED UNDER
C           STATEMENT 304
C
601 FORMAT (3F10.4,F15.5,F10.4,F15.5)
641 CALL BEAM(ALEN,ZI,AX,YM,BMK,GI,GM)
      IF (NTYPE.NE.6.AND.NTYPE.NE.7) GO TO 642
      ACOS = HL/ALEN
      ASIN = VL/ALEN
      DO 102 I = 1,6
      DO 102 J = 1,6
102  TRANS(I,J) = 0.
      TRANS(1,1) = ACOS
      TRANS(2,2) = ACOS
      TRANS(3,3) = 1.0
      TRANS(1,2) = ASIN
      TRANS(2,1) = -ASIN
      DO 104 I = 1,3
      DO 104 J = 1,3
104  TRANS(I+3,J+3) = TRANS(I,J)
      CALL MATMUL(BMK,TRANS,6,6,6,6,1,DIAG)
      DO 105 I = 1,6
      DO 105 J = 1,6
105  BMK(I,J) = DIAG(I,J)
642  CONTINUE
      IF (NRD.EQ.0) GO TO 643
      DO 645 I = 1, KKUREL
      DO 645 J = 1, KKUREL
645  STIF(I,J) = BMK(LND(I),LND(J))
643  IF (LIKE.EQ.0) GO TO 701
      DO 730 I = 1,6
      DO 731 J = 1,6
      SSK(I,J,LIKE) = BMK(I,J)
731  CONTINUE
730  CONTINUE
      GO TO 701
302 READ (5,602) ALEN,ZI,YI,AX,YM,GI,GM
C
C           THIS STATEMENT READS IN THE GEOMETRIC AND ELASTIC
C           PROPERTIES FOR A COLUMN ELEMENT (TYPE 2 AND 4). UNLESS
C           GIVEN BELOW, THE DEFINITIONS ARE THE SAME AS THOSE GIV-
C           EN BELOW STMT 304 FOR THE DIAGONAL ELEMENT.

```

```

C      ALEN = LENGTH OF THE MEMBER.
C      ZI = MOMENT OF INERTIA ABOUT THE AXIS OF BENDING
C      ASSOCIATED WITH DEGREES OF FREEDOM 5 AND 10. SEE
C      FIG. A2.
C      YI = MOMENT OF INERTIA ABOUT THE AXIS OF BENDING
C      ASSOCIATED WITH DEGREES OF FREEDOM 3 AND 8.
C
602  FORMAT (4F10.4,F15.5,F10.4,F15.5)
      CALL COLUM(ALEN,ZI,YI,AX,YM,CLK,GI,GM)
      IF (NRD.EQ.0) GO TO 644
      DO 646 I = 1, KKUREL
      DO 646 J = 1, KKUREL
646  STIF(I,J) = CLK(LND(I),LND(J))
644  IF (LIKE.EQ.0) GO TO 701
      DO 732 I = 1, 10
      DO 733 J = 1, 10
      SSK(I,J,LIKE) = CLK(I,J)
733  CONTINUE
732  CONTINUE
      GO TO 701
303  READ (5,603) NLXY,NUYX,LY,LX,EX,EY,T,G
C
C      THIS STATEMENT READS IN THE GEOMETRIC AND ELASTIC
C      PROPERTIES REQUIRED TO GENERATE THE ORTHOTROPIC PLANE
C      STRESS ELEMENT STIFFNESS MATRIX (TYPE 3 AND 5). THE
C      VARIABLES READ IN ARE :
C      NUXY = THE POISSON'S RATIO RELATING STRAINS IN THE
C      Y DIRECTION TO STRESSES IN THE X DIRECTION.
C      NUYX = THE POISSON'S RATIO RELATING STRAINS IN THE
C      X DIRECTION TO STRESSES IN THE Y DIRECTION.
C      LY = LENGTH OF THE ELEMENT SIDE IN THE Y DIRECTION
C      ( SHOWN AS B IN FIG. B1).
C      LX = LENGTH OF THE ELEMENT SIDE IN THE X DIRECTION
C      ( SHOWN AS A IN FIG. B1).
C      EX = ELASTIC MODULUS IN THE X DIRECTION.
C      EY = ELASTIC MODULUS IN THE Y DIRECTION.
C      T = ELEMENT THICKNESS.
C      G = SHEAR MODULUS OF THE ELEMENT.
C
603  FORMAT (2F5.3,2F10.4,2F15.5,F5.2,F15.5)
      CALL PLATE(NUXY,NUYX,LY,LX,EX,EY,T,G,PLK)
      IF (NRD.EQ.0) GO TO 647
      DO 648 I = 1, KKUREL
      DO 648 J = 1, KKUREL
648  STIF(I,J) = PLK(LND(J),LND(J))
647  IF (LIKE.EQ.0) GO TO 701
      DO 734 I = 1, 8
      DO 735 J = 1, 8
      SSK(I,J,LIKE) = PLK(I,J)
735  CONTINUE
734  CONTINUE
      GO TO 701
720  LIKE=-LIKE
      GO TO (741,742,743,742,743,741,741), NTYPE

```

```

741 DO 751 I = 1,6
      DO 752 J = 1,6
      BMK(I,J) = SSK(I,J,LIKE)
752 CONTINUE
751 CONTINUE
      IF (NRD.EQ.0) GO TO 701
      DO 649 I = 1, KKUREL
      DO 649 J = 1, KKUREL
649 STIF(I,J) = BMK(LND(I),LND(J))
      GO TO 701
742 DO 753 I = 1,10
      DO 754 J = 1,10
      CLK(I,J) = SSK(I,J,LIKE)
754 CONTINUE
753 CONTINUE
      IF (NRD.EQ.0) GO TO 701
      DO 650 I = 1, KKUREL
      DO 650 J = 1, KKUREL
650 STIF(I,J) = CLK(LND(I),LND(J))
      GO TO 701
743 DO 755 I = 1,8
      DO 756 J = 1,8
      PLK(I,J) = SSK(I,J,LIKE)
756 CONTINUE
755 CONTINUE
      IF (NRD.EQ.0) GO TO 701
      DO 651 I = 1, KKUREL
      DO 651 J = 1, KKUREL
651 STIF(I,J) = PLK(LND(I),LND(J))
      GO TO 701
701 CONTINUE
      IF (NRD.EQ.0) GO TO 652
5009 READ (5,604) (LRD(I), I = 1, NRD)
5010 READ (5,604) (LZD(I), I = 1, NRD)

```

```

C
C      THESE TWO READ STMTS READ DATA NECESSARY TO CARRY
C      OUT THE CONDENSATION OF THE ELEMENT STIFFNESS MATRIX
C      POSSIBLE WHEN A FORCE COMPONENT IS PRESCRIBED TO BE
C      ZERO. SEE EQUATIONS 3.1 THRU 3.5 FOR THE MATRIX MANIP-
C      ULATIONS INVOLVED, WHICH IN THIS CASE ARE DONE ON AN
C      ELEMENT STIFFNESS MATRIX. THE VECTOR LRD GIVES THE NUM-
C      BER OF THE ELEMENT CORRESPONDING TO THE RELEASED DEGREE
C      OF FREEDOM IN THE VECTOR LND. THE VECTOR LZD GIVES THE
C      NUMBER OF THE RELEASED DEGREE OF FREEDOM IN THE ELEMENT
C      NUMBERING SYSTEM.
C

```

```

      IF (LFORCE(NELEM).NE.0) WRITE (3) (LRD(I), I=1, NRD)
      NEW = 1
      IK = 1
      DO 11 I = 1, KKUREL
      IF (LND(I).EQ.LZD(IK)) GO TO 12
      LMD(NEW) = LND(I)
      NEW = NEW + 1
      GO TO 11

```

```

12 IK = IK + 1
   IF (IK.GT.NRD) IK = NRD
11 CONTINUE
   CALL RELMEM(STIF,KKUREL)
652 IF (NTYPE.NE.4) GO TO 391
   DO 380 I = 1,12
   DO 381 J = 1,12
   C(I,J) = 0.0
   FLK(I,J) = 0.0
   TC(I,J) = 0.0
381 CONTINUE
380 CONTINUE
5011 READ (5,382) XCR,YCR

```

```

C
C      THIS STATEMENT READS IN THE COORDINATES OF A COL-
C      UMN REFERRED TO A REFERENCE POINT. THESE ARE USED IN
C      STRUCTURES WITH RIGID FLOOR SYSTEMS. SEE REF. 16 FOR AN
C      EXPLANATION OF THE TREATMENT OF RIGID FLOORS. THE REF-
C     ERENCE POINT CAN BE ANYWHERE ON THE FLOOR. THE DISPLA-
C      CEMENT OUTPUT THAT RESULTS GIVES THE DISPLACEMENTS OF
C      THE REFERENCE POINT, THE VERTICAL DISPLACEMENT OF EACH
C      NODE AND THE ROTATIONS OF EACH JOINT. THE DISPLACEMENTS
C      OF THE INDIVIDUAL JOINTS IN THE PLANE OF THE FLOOR ARE
C      NOT CALCULATED. THIS STATEMENT IS BYPASSED UNLESS
C      A TYPE 4 ELEMENT IS USED.
C

```

```

382 FORMAT (8F10.0)
   TC(1,1) = 1.0
   TC(1,3) = -YCR
   TC(2,2) = 1.0
   TC(2,3) = XCR
   TC(3,4) = 1.0
   TC(4,5) = 1.0
   TC(5,6) = 1.0
   DO 383 I = 1,5
   DO 384 J = 1,6
   TC(I+5,J+6) = TC(I,J)
384 CONTINUE
383 CONTINUE
   IF (NRD.EQ.0) GO TO 450
   DO 451 I = 1,KUREL
   DO 451 J = 1,12
451 TCT(I,J) = TC(LMD(I),J)
   CALL MATMUL(STIF,TCT,KUREL,KUREL,KUREL,12,1,STIFF)
   GO TO 392
450 DO 385 I = 1,12
   DO 386 J = 1,10
   DO 387 K = 1,10
   C(I,J) = TC(K,I)*CLK(K,J) + C(I,J)
387 CONTINUE
386 CONTINUE
385 CONTINUE
   DO 388 I = 1,12
   DO 389 J = 1,12

```



```

DO 390 K = 1,10
  FLK(I,J) = C(I,K)*TC(K,J) + FLK(I,J)
390 CONTINUE
389 CONTINUE
388 CONTINUE
391 CONTINUE
  IF (NTYPE.NE.5) GO TO 392
5012 READ (5,382) C1,C2,C3,C4
C
C      THIS STATEMENT READS THE COORDINATES RELATIVE TO A
C REFERENCE POINT OF THE NODES OF A TYPE 5 (PLANE STRESS)
C ELEMENT. REFERRING TO FIGURE B1, C1 IS ASSOCIATED WITH
C THE LOWER LEFT CORNER, C2 WITH THE LOWER RIGHT AND SO
C ON COUNTERCLOCKWISE AROUND THE ELEMENT. BECAUSE A TYPE
C 5 ELEMENT HAS DISPLACEMENTS ONLY IN ITS OWN PLANE, ONLY
C COORDINATES PARALLEL TO THAT PLANE ARE REQUIRED. E. G.,
C IF THE ELEMENT IS IN THE X-Z PLANE THEN X COORDINATES
C ARE READ IN. THE TRANSFORMATION APPLIED TO THE ELEMENT
C STIFFNESS MATRIX TO ACCOUNT FOR THE FLOOR RIGIDITY IS
C SIMILAR TO THAT SHOWN IN REF. 16 FOR COLUMN MEMBERS.
C
DO 150 I = 1,8
  DO 151 J = 1,8
    TP(I,J) = 0.0
    PLKR(I,J) = 0.0
    D(I,J) = 0.0
151 CONTINUE
150 CONTINUE
  TP(1,1) = 1.0
  TP(1,2) = C1
  TP(2,3) = 1.0
  TP(3,1) = 1.0
  TP(3,2) = C2
  TP(4,4) = 1.0
  TP(5,5) = 1.0
  TP(5,6) = C3
  TP(6,7) = 1.0
  TP(7,5) = 1.0
  TP(7,6) = C4
  TP(8,8) = 1.0
  IF (NRD.EQ.0) GO TO 452
  DO 453 I = 1,KUREL
    DO 453 J = 1,8
453 TCT(I,J) = TP(LMD(I),J)
    CALL MATMUL (STIF,TCT,KUREL,KUREL,KUREL,8,1,STIFF)
    GO TO 392
452 DO 152 I = 1,8
  DO 153 J = 1,8
  DO 154 K = 1,8
    D(I,J) = TP(K,I)*PLK(K,J) + D(I,J)
154 CONTINUE
153 CONTINUE
152 CCNTINUE
DO 155 I = 1,8

```

```

DO 156 J = 1,8
DO 157 K = 1,8
PLKR(I,J) = D(I,K)*TP(K,J) + PLKR(I,J)
157 CONTINUE
156 CONTINUE
155 CONTINUE
392 CONTINUE
GO TO 395
400 READ (5,401) ((SHPAN(I,J), I=1,J), J=1,12)

```

C  
C THIS STATEMENT READS IN DIRECTLY THE UPPER HALF  
C TRIANGLE OF THE STIFFNESS MATRIX OF AN ELEMENT WITH 12  
C DOF.  
C

```

401 FORMAT (5D16.8)
GO TO 395
404 READ (5,402) ((SPR(I,J), I=1,J), J=1,2)

```

C  
C THIS STATEMENT READS IN THE UPPER HALF TRIANGLE  
C OF THE STIFFNESS MATRIX OF A LINEAR SPRING.  
C

```

402 FORMAT (4F10.0)
395 CONTINUE
IF (NTYPE.NE.7) GO TO 393
DO 394 I = 1,6
DO 394 J = 1,8
394 TD(I,J) = 0.0
5013 READ (5,382) C5,C6

```

C  
C THIS STATEMENT READS THE COORDINATES RELATIVE TO A  
C REFERENCE POINT OF THE ENDS OF A DIAGONAL MEMBER. THE  
C COORDINATES REQUIRED ARE THOSE PARALLEL TO THE PLANE OF  
C THE MEMBER. IF THE MEMBER LIES IN THE Y-Z PLANE, THEN  
C THE Y COORDINATES ARE REQUIRED. AGAIN, THE TRANSFORMA-  
C TION REQUIRED IS SIMILAR TO THAT GIVEN IN REF. 16. C5  
C IS THE COORDINATE OF THE LOWER END OF THE MEMBER AS  
C SHOWN IN FIG. A6 AND C6 THE COORDINATE OF THE UPPER  
C END.  
C

```

TD(1,1) = 1.0
TD(1,2) = C5
TD(2,3) = 1.0
TD(3,4)=1.0
TD(4,5) = 1.0
TD(4,6)=C6
TD(5,7) =1.0
TD(6,8) = 1.0
IF (NRD.EQ.0) GO TO 460
DO 454 I = 1,KUREL
DO 454 J =1,8
454 TCT(I,J) = TD(LMD(I),J)
CALL MATMUL (STIF,TCT,KUREL,KUREL,KUREL,8,1,STIFF)
GO TO 393
460 CALL MATMUL(BMK,TD,6,6,6,8,1,DIAG)

```

```
393 CONTINUE
    IF (KK.EQ.3) GO TO 980
    CALL SIMCN
    NGUID=IABS(NGUIDE)
    GO TO (1,2),NGUID
    IF (KK.EQ.2) GO TO 1
980 CONTINUE
    KUREL = LOOP
    NRD = LOOP1
    RETURN
1  WRITE(1) KUREL,LPREQ,(LVABL(I),LDEST(I),I=1,KUREL),
1  LZ,(EL(I),I=1,LZ)
    GO TO 3
2  WRITE(1) LZ,(EL(I),I=1,LZ)
3  CONTINUE
    RETURN
    END
```



```

      GO TO 305
321 EL(KOUNT) = STIFF(J,I)
305 KOUNT=KOUNT+1
      10 CONTINUE
      DO 307 I = KOUNT,LZ
307 EL(I) = 0,0
      IF (NRE.EQ.0) GO TO 325
5014 READ (5,900) (NR(I), I = 1,NRE)
C
C      THIS READ STATEMENT READS IN THE ELEMENT NUMBERS
C      OF VECTOR LND WHICH CORRESPOND TO THE SUPPORTED DEGREES
C      OF FREEDOM IN THE ELEMENT. IF TWO OR MORE ELEMENTS HAVE
C      A SUPPORTED DEGREE OF FREEDOM IN COMMON, ONLY ONE
C      SHOULD HAVE A CARD TO READ IN VECTOR NR.
C
      DO 322 I = 1,NRE
      NP = NR(I) + (NR(I)*(NR(I)-1))/2
322 EL(NP) = EL(NP) + 1.00+20
325 CONTINUE
900 FORMAT (16I5)
      IF (LOAD.EQ.0) GO TO 308
5015 READ (5,310) (JJ(I),P(I), I = 1,LOAD)
310 FORMAT (8(I3,F6.0))
C
C      THIS READ STATEMENT READS THE DATA NECESSARY TO
C      CREATE THE ELEMENT LOAD VECTOR. VECTOR JJ(I) CONTAINS
C      THE POSITION OF THE ELEMENTS IN VECTOR LND WHICH COR-
C      RESPOND TO LOADED DEGREES OF FREEDOM. IF THE DEGREE OF
C      FREEDOM CORRESPONDING TO THE THIRD ELEMENT OF VECTOR
C      LND IS LOADED, THEN JJ(I) = 3. VECTOR P(I) CONTAINS THE
C      VALUE OF THE LOADS, WITH CORRECT SIGN.
C
      DO 311 I=1,LOAD
      EL(KOUNT + JJ(I) - 1) = P(I)
311 CCNTINUE
308 CONTINUE
319 FORMAT (12F6.0)
340 CONTINUE
      RETURN
      END

```

```

SUBROUTINE MINV(A,NM)
C
C      SUBROUTINE MINV INVERTS MATRICES UP TO 12 X 12 BY
C      THE GAUSS JORDAN METHOD. IT WAS WRITTEN BY P. C. WANG
C      AND IS PUBLISHED IN REF. 61. THE ARGUMENTS ARE:
C      A = SQUARE MATRIX OF SIZE UP TO 12 X 12 WHICH IS
C      TO BE INVERTED.
C      NM = NUMBER OF ROWS OR COLUMNS IN MATRIX A.
C
      IMPLICIT REAL*8(A-H,O-Z)
      DIMENSION A(12,12),U(12,12)
      DO 101 I=1,NM
      DO 101 J = 1,NM
      U(I,J) = 0.0
      IF (I.EQ.J) U(I,J) = 1.0
101 CONTINUE
      EPS=.0000001
      DO 102 I = 1,NM
      K = I
      IF (I-NM) 9021,9007,9021
9021 IF(A(I,I)-EPS) 9005,9006,9007
9005 IF(-A(I,I)-EPS) 9006,9006,9007
9006 K = K+1
      DO 9023 J = 1,NM
      U(I,J) = U(I,J) + U(K,J)
9023 A(I,J) = A(I,J) + A(K,J)
      GO TO 9021
9007 DIV = A(I,I)
      DO 9009 J = 1,NM
      U(I,J) = U(I,J)/DIV
9009 A(I,J) = A(I,J)/DIV
      DO 102 MM = 1,NM
      DELT = A(MM,I)
      IF (CABS(DELT)-EPS) 102,102,9016
9016 IF (MM-I) 9010,102,9010
9010 DO 9011 J = 1,NM
      U(MM,J) = U(MM,J) - U(I,J)*DELT
9011 A(MM,J) = A(MM,J) - A(I,J)*DELT
      102 CCNTINUE
      DO 9033 I = 1,NM
      DO 9033 J = 1,NM
9033 A(I,J) = U(I,J)
      RETURN
      END

```

## SUBROUTINE RELMEM(STIFF,NC)

C  
C  
C SUBROUTINE RELMEM CARRIES OUT THE MATRIX MANIPU-  
C LATIONS NECESSARY TO CONDENSE THE STIFFNESS MATRIX OF  
C AN ELEMENT WHICH HAS A RELEASED DEGREE OF FREEDOM, I.  
C E. A PRESCRIBED ZERO FORCE COMPONENT. THE ARGUMENTS OF  
C RELMEM ARE:  
C STIFF = ELEMENT STIFFNESS MATRIX WHICH IS TO BE  
C CONDENSED. ON RETURN TO SUBROUTINE ELMAX OR FORCE,  
C STIFF CONTAINS THE CONDENSED MATRIX.  
C NC = NUMBER OF ROWS OR COLUMNS IN MATRIX STIFF.  
C

```

      IMPLICIT REAL*8(A-H,O-Z)
      DIMENSION ARP(12,12)
      DIMENSION MRD(12),RR(12,12),RRI(12,12),RF(12,12),STIFF
C   (12,12),
      1  FF(12,12),SMOD(12,12),SSTAR(12,12)
      COMMON /BLK11/ MVABL(80),LVABL(80),LND(80),LDEST(80),L
C   RD(12)
      COMMON /BLK12/ INITL,NTIREX,NEWRHS,NELEM,NELEMZ,KUREL,
C   LPREQ,
      1  LZ,NELZ,NBAXO,NBZ,KL,LDES,NSTRES,KK
      COMMON /BLK15/ NTYPE,NRD
      DO 107 I = 1,NC
      MRD(I) = 0
107  CONTINUE
      DO 108 J = 1,NRD
108  MRD(LRD(J)) = LRD(J)
      K = 1
      L = 1
      DO 100 I = 1,NC
      IF (I.NE.MRD(I)) GO TO 100
      DO 101 J = 1,NC
      IF (J.NE.MRD(J)) GO TO 101
      RR(K,L) = STIFF(MRD(I),MRD(J))
      RRI(K,L) = RR(K,L)
      L = L + 1
101  CONTINUE
      L = 1
      K = K + 1
100  CONTINUE
      L = 1
      K = 1
      DO 102 I = 1,NC
      IF (I.EQ.MRD(I)) GO TO 102
      DO 103 J = 1,NC
      IF (J.NE.MRD(J)) GO TO 103
      RF(L,K) = STIFF(MRD(J),I)
      L = L + 1
103  CONTINUE
      L = 1
      K = K + 1
102  CONTINUE
      L = 1

```

```
K = 1
DC 104 I = 1,NC
IF (I.EQ.MRD(I)) GO TO 104
DO 106 J = 1,NC
IF (J.EQ.MRD(J)) GO TO 106
FF(K,L) = STIFF(I,J)
L = L + 1
106 CONTINUE
L = 1
K = K + 1
104 CONTINUE
CALL MINV(RRI,NRD)
MM=1
NR2 = NC-NRD
CALL MATMUL(RRI,RF,NRD,NRD,NRD,NR2,MM,SMOD)
DO 105 I = 1,NR2
DO 105 J = 1,NR2
STIFF(I,J) = FF(I,J) - SMOD(I,J)
105 CONTINUE
RETURN
END
```





```

NOC(1) = LOC(KL1)
KURELS = NTORE(NOC(NE))
NAD = NTORE(NOC(NE)+1)
KKUREL = KURELS + NAD
DO 36 I = 1, KURELS
36 NVABL(I) = NTORE(NOC(NE)+1+I)
   NTYPE = NTORE(NOC(NE)+2+KURELS)
   LIKE = NTORE(NOC(NE)+3+KURELS)
DO 37 I = 1, KKUREL
37 LND(I) = NTORE(NOC(NE)+3+KURELS+I)
   NOC(NE+1) = NOC(NE)+4+KURELS+KKUREL
   KL1 = -KL1
32 CONTINUE
   IF (LIKE.LT.0) LIKE=-LIKE
   NRD = NAD
   CALL FORCE1(           KKUREL,LND,LIKE,NVABL,DISP,KUREL
C   S)
   NAD = NRD
   WRITE (6,901) NOEL,NE
   WRITE (6,900) (I,FOR(I,1),I = 1,KURELS)

```

C  
C  
C  
C

THESE TWO WRITE STATEMENTS WRITE OUT THE MEMBER FORCES FOR MEMBERS WHICH ARE PART OF SUBASSEMBLIES.

```

11 CONTINUE
   IF (KL1.GT.0) LOC(KL1+1) = NOC(KE+1)
900 FORMAT (6(I5,D15.6))
901 FORMAT (//,6X,8HELEMENT ,I4,10X,7HMEMBER ,I4,12H FORC
C   ES ARE)
   GO TO 20
10 DO 13 I = 1, KUREL
   ELL(I) = ELPA(LVABL(I))
13 IF (DABS(ELPA(LVABL(I))).LT.1.0D-14) ELL(I) = 0.0D+0C
   KKUREL = KUREL + NRD
   READ (3) NTYPE,LIKE,(LND(I),I=1,KKUREL)
   IF (LIKE.LT.0) LIKE=-LIKE
   DO 50 I = 1, KUREL
50 LVABL(I) = I
   CALL FORCE1(           KKUREL,LND,LIKE,LVABL,ELL,KUREL)
   WRITE (6,902) NOEL
902 FORMAT (//,6X,8HELEMENT ,I4,12H FORCES ARE)
   WRITE (6,900) (I,FOR(I,1),I=1,KUREL )

```

C  
C  
C  
C

THESE TWO WRITE STATEMENTS WRITE OUT THE FORCES FOR MEMBERS WHICH ARE NOT PART OF SUBASSEMBLIES.

```

910 FORMAT (16I5)
20 CONTINUE
   REWIND 3
   RETURN
   END

```

```
SUBROUTINE FORCE1(KKUREL,LNS,LIKE,NVABL,DISP,KURELS)
```

```
C
C   SUBROUTINE FORCE1 DOES THE ACTUAL FORCE CALCULA-
C   TION. IT RETRIEVES THE MEMBER STIFFNESS MATRIX FROM
C   THE 3-D MATRIX SSK, DOES THE MANIPULATIONS REQUIRED FOR
C   RELEASES IF ANY, AND THEN MULTIPLIES THE STIFFNESS MA-
C   TRIX TIMES THE DISPLACEMENT VECTOR. NOTE THAT THE CAL-
C   CULATION OF FORCES FOR ELEMENTS TYPE 4, 5 AND 7 HAS NOT
C   BEEN IMPLEMENTED. THE ARGUMENTS ARE DEFINED AS FOLLOWS:
C   KKUREL = NUMBER OF ACTIVE DEGREES OF FREEDOM IN
C   THE ELEMENT WHOSE FORCES ARE BEING CALCULATED.
C   LNS = VECTOR OF ACTIVE DEGREE OF FREEDOM NUMBERS
C   IN ELEMENT NUMBERING SYSTEM.
C   LIKE = INDEX TO DETERMINE WHAT 2-D MATRIX IS TO BE
C   RETRIEVED FROM THE 3-D MATRIX SSK.
C   NVABL = VECTOR OF ACTIVE DEGREES OF FREEDOM IN
C   SUBASSEMBLY OR STRUCTURE NUMBERING SYSTEM.
C   DISP = VECTOR OF ELEMENT DISPLACEMENTS.
C   KURELS = NUMBER OF ACTIVE, UNRELEASED DEGREES OF
C   FREEDOM IN THE ELEMENT.
```

```

C   IMPLICIT REAL*8(A-H,O-Z)
C   DIMENSION LNS(12)
C   DIMENSION DISP(40),NVABL(40)
C   DIMENSION NTORE(20,20,2)
C   DIMENSION CONG(12,12)
C   DIMENSION DISP1(12,12)
C   COMMON /BLK16/ DIAG(12,12),STIF(12,12),TCT(12,12),STIF
C   F(12,12)
C   COMMON /BLK50/ FOR(12,12)
C   COMMON /BLK53/ SSK(12,12,32)
C   COMMON /BLK11/ MVABL(80),LVABL(80),LND(80),LDEST(80),L
C   RD(12)
C   COMMON /BLK15/ NTYPE,NRD
C   COMMON /BLK31/ KE,KL1,NAD,NE
C   NAD = NRD
C   GO TO (13,13,13,16,17,13,19), NTYPE
16 CONTINUE
17 CONTINUE
19 CONTINUE
13 IF (NAD.EQ.0) GO TO 20
   IF (KL1.GE.0) READ (3) (LRD(I),I=1,NAD)
   IF (KL1.LE.0) GO TO 30
   DO 31 I = 1,NAD
31 NTORE(KL1,NE,I) = LRD(I)
   GO TO 32
30 IF (KL1.EQ.0) GO TO 32
   KL1 = -KL1
   DO 33 I = 1,NAD
33 LRD(I) = NTORE(KL1,NE,I)
   KL1 = -KL1
32 CONTINUE
   DO 21 I = 1, KKUREL
   DO 21 J = 1, KKUREL
```

```
21 STIF(I,J) = SSK(LNS(I),LNS(J),LIKE)
   CALL RELMEM(STIF, KKUREL)
   DO 22 I = 1, KURELS
22  DISP1(I,1) = DISP(NVABL(I))
   CALL MATMUL(STIF, DISP1, KURELS, KURELS, KURELS, 1, 0, CONG)
   RETURN
20 DO 24 I = 1, KURELS
   DISP1(I,1) = DISP(NVABL(I))
   DO 24 J = 1, KURELS
24  STIF(I,J) = SSK(LNS(I),LNS(J),LIKE)
25  CALL MATMUL(STIF, DISP1, KURELS, KURELS, KURELS, 1, 0, CONG)
   RETURN
   END
```

## SUBROUTINE STIGEN

C  
C  
C  
C  
C

SUBROUTINE STIGEN ASSEMBLES A NUMBER OF ELEMENT STIFFNESS MATRICES INTO A SUBASSEMBLY STIFFNESS MATRIX FOR USE AS INPUT INTO THE ELIMINATION ROUTINE.

```

      IMPLICIT REAL*8(A-H,O-Z)
      DIMENSION P(12),PA(12),JJ(12),NVABL(12)
      COMMON /BLK10/ ELPA(12000),ELCOR(3,4),STEFF(900),BMK(1
C 2,12),
      1 CLK(12,12),PLK(12,12)
      COMMON /BLK13/ FLK(12,12),PLKR(12,12)
      COMMON /BLK16/ DIAG(12,12),STIF(12,12),TCT(12,12),STI
C FF(12,12)
      COMMON /BLK1/ SHPAN(24,24),SPR(2,2)
      COMMON /BLK82/ LFORCE(500)
      COMMON /BLK32/ STORE(2100),LOC(16)
      COMMON /BLK12/ INITL,NTIREX,NEWRHS,NELEM,NELEMZ,KUREL,
C LPREQ,
      1 LZ,NELZ,NBAXO,NEZ,KL,LDES,NSTRES,KK
      COMMON /BLK11/ MVABL(80),LVABL(80),LND(80),LDEST(80),L
C RD(12)
      COMMON /BLK14/ LOAD
      COMMON /BLK15/ NTYPE,NRD
      COMMON /BLK30/ KURELS
      COMMON /BLK31/ KE,KL1,NAD,NE
      COMMON /BLK81/ NRE,KL2,NFORCE
      NPMAX = (KUREL+1)*KUREL/2
      LZ = NPMAX + KUREL*NEWRHS
      DO 100 I = 1,900
      100 STEFF(I) = 0.0
      900 FORMAT (16I5)
      118 DO 120 NE = 1,KE

```

C  
C  
C  
C  
C  
C

THIS LOOP GOES THROUGH THE MEMBERS OF THE SUBROUTINE ONE AT A TIME, PLACING THE MEMBER STIFFNESS MATRIX IN VECTOR STEFF AND READING IN LOADS, IF ANY.

```

5016 READ (5,900) KURELS,NAD

```

C  
C  
C  
C  
C  
C  
C  
C  
C

THIS STATEMENT READS IN THE NUMBER OF ACTIVE UNRELEASED DEGREES OF FREEDOM AND THE NUMBER OF ACTIVE, RELEASED DEGREES OF FREEDOM.

KURELS = NUMBER OF ACTIVE, UNRELEASED DEGREES OF FREEDOM IN MEMBER NUMBER NE OF THIS SUBASSEMBLY.  
NAD = NUMBER OF ACTIVE, RELEASED DEGREES OF FREEDOM IN MEMBER NE.

```

5017 READ (5,900) (NVABL(I), I = 1,KURELS)

```

C  
C  
C  
C  
C

VECTOR NVABL IS THE LIST OF ACTIVE, UNRELEASED DEGREES OF FREEDOM IN SUBASSEMBLY TERMS.

```

      IF (LFORCE(NELEM).NE.0) WRITE (3) KURELS,NAD,(NVABL(I)

```

```

C ,I=1,KURELS)
CALL ELMAX
101 DO 103 I = 1,KURELS
    DO 103 J = 1,I
    IF (NVABL(J).LE .NVABL(I)) GO TO 141
    NVAB1 = NVABL(J)
    NVAB2 = NVABL(I)
    NP = NVAB2 + (NVAB1*(NVAB1-1))/2
    GO TO 158
141 NP = NVABL(J) + (NVABL(I)*(NVABL(I)-1))/2
158 IF (NAC.NE.0) GO TO 156
    IF (NTYPE.EQ.8) GO TO 401
    GO TO (150,151,152,153,154,150,155), NTYPE
156 IF (NTYPE.EQ.4.OR.NTYPE.EQ.5.OR.NTYPE.EQ.7) GO TO 157
    STEFF(NP) = STIF(J,I) + STEFF(NP)
    GO TO 103
157 STEFF(NP) = STIFF(J,I) + STEFF(NP)
    GO TO 103
150 STEFF(NP) = BMK(LND(J),LND(I)) + STEFF(NP)
    GO TO 103
151 STEFF(NP) = CLK(LND(J),LND(I)) + STEFF(NP)
    GO TO 103
152 STEFF(NP) = PLK(LNC(J),LND(I)) + STEFF(NP)
    GO TO 103
153 STEFF(NP) = FLK(LND(J),LND(I)) + STEFF(NP)
    GO TO 103
154 STEFF(NP) = PLKR(LND(J),LND(I)) + STEFF(NP)
    GO TO 103
155 STEFF(NP) = DIAG(LND(J),LND(I)) + STEFF(NP)
    GO TO 103
401 STEFF(NP) = SHPAN(LND(J),LND(I)) + STEFF(NP)
103 CONTINUE
121 DO 105 I = 1,KURELS
105 PA(I) = 0.0
120 CONTINUE
    IF (KL1.EQ.0) RETURN
    DO 130 I = 1,LZ

```

```

C
C           THIS LOOP STORES THE SUBASSEMBLY STIFFNESS MATRIX
C           IF IT WILL BE NEEDED LATER IN THE PROGRAM.
C

```

```

130 STORE(LOC(KL1)-1+I) = STEFF(I)
    LOC(KL1+1) = LOC(KL1) + LZ
    RETURN
    END

```

```

C

```

ORGANIZATION OF THE DATA IN THE PROGRAM

IN THIS SECTION, THE MANNER IN WHICH THE DATA SHOULD BE FED IN IS EXPLAINED. THIS WILL BE DONE BY GIVING IN THE PROPER ORDER THE READ STATEMENT NUMBER FOR WHICH DATA MUST BE PROVIDED, AND INDICATING IF THE CARD MUST BE PRESENT OR IF IT IS NECESSARY ONLY UNDER CERTAIN CIRCUMSTANCES WHICH WILL BE NOTED. THE DATA IS GROUPED INTO TWO MAIN SETS. THE FIRST PROVIDES BASIC INFORMATION ABOUT THE ELEMENT/SUBASSEMBLY, AND THE SECOND PROVIDES THE INFORMATION NECESSARY TO GENERATE THE ELEMENT STIFFNESS MATRICES.

THE FIRST AND SECOND CARDS CONTAIN THE TITLE OF THE PROBLEM READ IN BY STMT 5001. TWO CARDS MUST ALWAYS BE PRESENT. THE THIRD CARD IS THE CONTROL INFORMATION READ BY STATEMENT 5002 AND MUST ALWAYS BE PRESENT.

NEXT COMES A GROUP OF TWO, THREE, OR FOUR CARDS FOR EACH ELEMENT/SUBASSEMBLY IN TURN. THE FIRST CARD OF EACH GROUP CONTAINS THE DATA READ IN BY STMT 5003. THE SECOND, THIRD AND FOURTH CARDS OF EACH GROUP CONTAIN THE DATA REQUIRED FOR READ STMT 5004. THE NUMBER OF CARDS REQUIRED FOR STMT 5004 DEPENDS ON THE NUMBER OF ACTIVE, UNRELEASED DEGREES OF FREEDOM, I. E. ON KUREL. THESE GROUPS OF CARDS MUST BE PRESENTED FOR EACH ELEMENT/SUBASSEMBLY IN THE STRUCTURE. AFTER A GROUP OF CARDS HAVE BEEN GIVEN FOR EACH ELEMENT/SUBASSEMBLY, THE NEXT CARD SHOULD CONTAIN ONLY A ZERO IN COLUMN FIVE. THIS IS THE END OF THE FIRST SET OF DATA.

THE NEXT SET OF DATA CONTAINS A VARIABLE NUMBER OF CARDS FOR EACH ELEMENT/ SUBASSEMBLY, DEPENDING ON THE ELEMENT TYPE AND SUBASSEMBLY SIZE. THE CARDS REQUIRED FOR THE VARIOUS ELEMENTS USED AS INDIVIDUAL MEMBERS ARE FIRST DESCRIBED AND THEN THE CARDS REQUIRED FOR SUBASSEMBLIES AND THEIR MEMBERS WILL BE DESCRIBED. THE CARDS REQUIRED FOR EACH SUBASSEMBLY/ELEMENT SHOULD BE PLACED IN THE DECK IN THE SAME ORDER AS THE ELEMENTS IN THE FIRST SET OF DATA.

A TABULAR FORMAT WILL BE USED TO INDICATE THE CARDS REQUIRED FOR EACH TYPE OF ELEMENT. THE COLUMN HEADINGS ARE OBVIOUS EXCEPT FOR THE LAST TWO. THE NEXT TO LAST COLUMN INDICATES THE SUBROUTINE IN WHICH THE READ STATEMENT APPEARS. THE LAST COLUMN INDICATES THE CIRCUMSTANCES UNDER WHICH THE CARD IS NEEDED. IN THE LAST COLUMN, GE MEANS THE CARD IS NECESSARY IF THE QUANTITY ON THE LEFT OF THE GE IS GREATER THAN OR EQUAL TO THE QUANTITY ON THE RIGHT. SIMILARLY, GT STANDS FOR GREATER THAN.

THE CARDS REQUIRED FOR EACH TYPE ELEMENT ARE:

C	ELEMENT	CARD	READ	SUBROUTINE	NEEDED IF
C	TYPE	NO.	STMT		
C	1	1	5008	ELMAK	MANDATORY
C		2	301	ELMAK	LIKE GE 0
C		3	5009	ELMAK	NRD GT 0
C		4	5010	ELMAK	NRD GT 0
C		5	5014	SIMON	NRE GT 0
C		6	5015	SIMON	LOAD GT 0
C	2	1	5008	ELMAK	MANDATORY
C		2	302	ELMAK	LIKE GE 0
C		3	5009	ELMAK	NRD GT 0
C		4	5010	ELMAK	NRD GT 0
C		5	5014	SIMON	NRE GT 0
C		6	5015	SIMON	LOAD GT 0
C	3	1	5008	ELMAK	MANDATORY
C		2	303	ELMAK	LIKE GE 0
C		3	5009	ELMAK	NRD GT 0
C		4	5010	ELMAK	NRD GT 0
C		5	5014	SIMON	NRE GT 0
C		6	5015	SIMON	LOAD GT 0
C	4	1	5008	ELMAK	MANDATORY
C		2	302	ELMAK	LIKE GE 0
C		3	5009	ELMAK	NRD GT 0
C		4	5010	ELMAK	NRD GT 0
C		5	5011	ELMAK	MANDATORY
C		6	5014	SIMON	NRE GT 0
C		7	5015	SIMON	LOAD GT 0
C	5	1	5008	ELMAK	MANDATORY
C		2	303	ELMAK	LIKE GE 0
C		3	5009	ELMAK	NRD GT 0
C		4	5010	ELMAK	NRD GT 0
C		5	5012	ELMAK	MANDATORY
C		6	5014	SIMON	NRE GT 0
C		7	5015	SIMON	LOAD GT 0
C	6	1	5008	ELMAK	MANDATORY
C		2	304	ELMAK	LIKE GE 0
C		3	5009	ELMAK	NRD GT 0
C		4	5010	ELMAK	NRD GT 0
C		5	5014	SIMON	NRE GT 0
C		6	5015	SIMON	LOAD GT 0
C	7	1	5008	ELMAK	MANDATORY
C		2	304	ELMAK	LIKE GE 0
C		3	5009	ELMAK	NRD GT 0
C		4	5010	ELMAK	NRD GT 0
C		5	5013	ELMAK	MANDATORY
C		6	5014	SIMON	NRE GT 0



C GED. FORCES IN ALL MEMBERS ARE DESIRED.  
 C  
 C THE REQUIRED DATA WITH EXPLANATIONS:  
 C  
 CD EXAMPLE PROBLEM  
 CD THREE STORY FRAME  
 CC THIS IS THE TITLE READ IN STMT 5001.  
 CD 1 1 1 8000 900 1  
 C THIS CARD IS FOR STMT 5002.  
 CD 6 0 0 0 0 0 1  
 CD 7 8 9 1 2 3  
 CC THESE CARDS ARE READ BY STMTS 5003 AND 5004. THEY  
 CC ARE FOR MEMBER 1 IN FIG. A7A. NOTE THE ORDER OF THE DE-  
 CC GREES OF FREEDOM. FOR A COLUMN ELEMENT, THE BOTTOM  
 CC DEGREES OF FREEDOM COME FIRST IN THE STIFFNESS MATRIX.  
 CD 6 0 0 0 0 0 1  
 CD 1 2 3 4 5 6  
 CD 6 0 0 0 0 0 1  
 CD 10 11 12 4 5 6  
 CD 12 0 3 1 0 1 1  
 CD 13 14 15 7 8 9 10 11 12 16 17 18  
 CC THESE TWO CARDS ARE READ BY STMTS 5003 AND 5004.  
 CC THEY ARE FOR THE SUBASSEMBLY LABELLED 4 IN FIG. A7A.  
 CC NOTE THAT THE ORDER IN WHICH THE DEGREES OF FREEDOM ARE  
 CC LISTED CORRESPONDS TO THE ORDER THEY ARE NUMBERED IN  
 CC FIG. A7B.  
 CD 12 0 3 -1 6 1 1  
 CD 19 20 21 13 14 15 16 17 18 22 23 24  
 CD 0  
 CC THIS ENDS THE FIRST SET OF DATA.  
 CD -1 2 1 0 1 4 5 6 9 10  
 CD 120. 200. 0.0 10.0 30000. 0.0  
 CC NOTE THAT THE LAST VALUE THAT SHOULD BE ON THIS CARD  
 CC HAS BEEN LEFT OFF IN ORDER TO FIT IN THE 60 COLUMN FOR-  
 CC MAT.  
 CC THESE CARDS ARE ALL THAT ARE REQUIRED FOR MEMBER 1  
 CC BECAUSE NRD = 0, NRE = 0 AND LOAD = 0. LOAD IS TAKEN =  
 CC 0 BECAUSE THE FORCE AT THE UPPER CORNER WILL BE INPUT  
 CC WITH THE DATA FOR MEMBER TWO. NOTE THAT SINCE THE DE-  
 CC GREES OF FREEDOM ASSOCIATED WITH THE SECOND AXIS OF  
 CC BENDING ARE NOT ACTIVE IN THIS PROBLEM, THE MOMENT OF  
 CC INERTIA ABOUT THAT AXIS CAN BE TAKEN = 0.0. THE VECTOR  
 CC LND HAS ONLY SIX ELEMENTS SINCE THIS IS A TWO DIMEN-  
 CC SIONAL PROBLEM. THE DEGREES OF FREEDOM NUMBERS IN THE  
 CC ELEMENT NUMBERING SYSTEM THAT ARE ACTIVE CAN BE FOUND  
 CC BY CONSIDERATION OF FIG. A2, WHICH SHOWS ALL THE  
 CC DEGREES OF FREEDOM FOR THE COLUMN ELEMENT.  
 CD -1 1 2 1 1 2 3 4 5 6  
 CD 240. 300. 10. 30000. 0.0 0.0  
 CD1 5.0  
 CC THESE CARDS CONTAIN THE INFORMATION REQUIRED FOR  
 CC MEMBER 2. THE LAST CARD CONTAINS THE LOAD INFORMATION  
 CC FOR THIS MEMBER.  
 CD -1 2 -1 0 1 4 5 6 9 10

CC THIS CARD HAS THE INPUT FOR MEMBER 3. NO MEMBER  
 CC PROPERTIES ARE REQUIRED BECAUSE THE STIFFNESS MATRIX IS  
 CC AVAILABLE FROM MEMBER 1.

CD 6 0  
 CD 1 2 3 4 5 6  
 CD -1 2 -1 0 1 4 5 6 9 10

CC THESE THREE CARDS CONTAIN THE DATA REQUIRED FOR  
 CC MEMBER 1 OF SUBASSEMBLY 4.

CD 6 0  
 CD 4 5 6 7 8 9  
 CD -1 1 -2 0 1 2 3 4 5 6

CC THESE CARDS CONTAIN THE DATA REQUIRED FOR MEMBER  
 CC 2 OF SUBASSEMBLY 4.

CD 6 0  
 CD 10 11 12 7 8 9  
 CD -1 2 -1 0 1 4 5 6 9 10

CC THESE THREE CARDS CONTAIN THE DATA REQUIRED FOR  
 CC MEMBER 3 OF SUBASSEMBLY 4. THE LAST NINE CARDS REPRE-  
 CC SENT THE DATA NECESSARY TO GENERATE THE SUBASSEMBLY  
 CC STIFFNESS MATRIX.

CD4 10.0

CC THIS CARD READS IN THE LOAD ON THIS SUBASSEMBLY.  
 CC 4 IS THE LOADED DEGREE OF FREEDOM AS CAN BE SEEN FROM  
 CC FIG. A7. NOTE THAT THE 30K VERTICAL LOAD HAS BEEN AS-  
 CC SUMED TO ACT ON SUBASSEMBLY 5, SO THERE IS ONE LOAD ON  
 CC EACH

CD5 -30.0

CC THIS CARD READS IN THE VERTICAL LOAD ON SUBASSEM-  
 CC BLY 5. THERE IS NO MEMBER DATA FOR THE SUBASSEMBLY BE-  
 CC CAUSE ITS STIFFNESS MATRIX IS IDENTICAL TO THAT OF SUB-  
 CC ASSEMBLY 4.

CD 1 2 3 10 11 12

CC THIS CARD READS IN THE DOF NUMBERS, IN THE SUBAS-  
 CC SEMBLY NUMBERING SYSTEM, OF THE SUPPORTED DEGREES OF  
 CC FREEDOM.

CD 0 7 19 20 21 22 23 24 0

CC THIS CARD CONTAINS THE DATA READ IN BY STATEMENT  
 CC 5007. THE DATA IS COMPLETE AND THE PROBLEM READY TO  
 CC RUN.

C

C

C

C

C

C

C

C

C

C

C

C

THE OUTPUT FROM THIS PROBLEM IS SHOWN IN FIG.  
 A8. THE SIGN CONVENTION USED FOR THE DISPLACEMENTS  
 IS SHOWN IN FIG. A7A. THE SAME SIGN CONVENTION HOLDS  
 FOR THE REACTIONS AND THE FORCES ON THE ENDS OF THE  
 MEMBERS.

IT IS ANTICIPATED THAT A USER ORIENTED PROGRAM  
 DEVELOPED FROM THIS RESEARCH PROGRAM WILL BE PUBLISHED  
 SOMETIME IN 1972 AS A CORNELL UNIVERSITY DEPARTMENT  
 OF STRUCTURAL ENGINEERING REPORT.

APPENDIX B  
 DERIVATION OF THE ORTHOTROPIC PLANE STRESS  
 RECTANGULAR ELEMENT STIFFNESS MATRIX

Using the principle of minimum potential energy<sup>(60)</sup>, the element stiffness matrix is

$$[k^e] = \int_V [D]^T [E] [D] dV \quad (B1)$$

where  $[E]$  = element rigidity matrix relating stress and strain

$$\{\sigma\} = [E]\{\epsilon\} \quad (B2)$$

For an orthotropic material in a state of plane stress, Equation (B2) becomes

$$\begin{Bmatrix} \sigma_x \\ \sigma_y \\ \sigma_{xy} \end{Bmatrix} = \begin{vmatrix} \frac{E_x}{\lambda} & \frac{E_x \nu_{yx}}{\lambda} & 0 \\ \frac{E_y \nu_{xy}}{\lambda} & \frac{E_y}{\lambda} & 0 \\ 0 & 0 & G_{xy} \end{vmatrix} \begin{Bmatrix} \epsilon_x \\ \epsilon_y \\ \epsilon_{xy} \end{Bmatrix} \quad (B3)$$

where  $\lambda = 1 - \nu_{yx}\nu_{xy}$ .

Fig. B1 shows the element under consideration and defines the coordinate directions. The axes of orthotropy are parallel to the coordinate axes. In equation (B1),  $[D]$  relates element

strains to element joint displacements;

$$\{\epsilon\} = [D]\{\Delta\} \quad (B4)$$

$[\Delta] = [u_1 \ v_1 \ u_2 \ v_2 \ u_3 \ v_3 \ u_4 \ v_4]$  for the plane stress rectangle shown in Fig. B1. For the plane stress situation, the strain-displacement relations are

$$\begin{Bmatrix} \epsilon_x \\ \epsilon_y \\ \epsilon_{xy} \end{Bmatrix} = \begin{Bmatrix} \frac{\partial u}{\partial x} \\ \frac{\partial v}{\partial y} \\ \frac{\partial u}{\partial y} + \frac{\partial v}{\partial x} \end{Bmatrix} \quad (B5)$$

Displacement functions which guarantee inter-element compatibility of displacements are

$$u = (1 - \frac{x}{a})(1 - \frac{y}{b})u_1 + \frac{x}{a}(1 - \frac{y}{b})u_2 + \frac{xy}{ab}u_3 + (1 - \frac{x}{a})\frac{y}{b}u_4 \quad (B6)$$

$$v = (1 - \frac{x}{a})(1 - \frac{y}{b})v_1 + \frac{x}{a}(1 - \frac{y}{b})v_2 + \frac{xy}{ab}v_3 + (1 - \frac{x}{a})\frac{y}{b}v_4$$

Applying Eqn. B5 to the displacement functions yields

$$[D] = \begin{bmatrix} \frac{-(1 - \frac{y}{b})}{a} & 0 & \frac{1 - \frac{y}{b}}{a} & 0 & \frac{y}{ab} & 0 & -\frac{y}{ab} & 0 \\ 0 & \frac{-(1 - \frac{x}{a})}{b} & 0 & -\frac{x}{ab} & 0 & \frac{x}{ab} & 0 & \frac{1 - \frac{x}{a}}{b} \\ \frac{-(1 - \frac{x}{a})}{b} & \frac{-(1 - \frac{y}{b})}{a} & -\frac{x}{ab} & \frac{1 - \frac{y}{b}}{a} & \frac{x}{ab} & \frac{y}{ab} & \frac{(1 - \frac{x}{a})}{b} & -\frac{y}{ab} \end{bmatrix} \quad (B7)$$

Substituting [E] and [D] into Eqn. (B1) and carrying out the matrix multiplications and the integrations yields the desired stiffness matrix. Typically, we have (with  $dV = t dx dy$ )

$$\begin{aligned}
 k_{12} &= t \int_V \frac{E_x \nu_{yx}}{\lambda_{ab}} (1 - \frac{y}{b})(1 - \frac{x}{a}) + \frac{G_{xy}}{ab} (1 - \frac{y}{b})(1 - \frac{x}{a}) dx dy \\
 &= \frac{t}{ab} \int_0^b \int_0^a \left[ \frac{E_x \nu_{yx}}{\lambda} (1 - \frac{y}{b})(1 - \frac{x}{a}) + \frac{G_{xy}}{ab} (1 - \frac{y}{b})(1 - \frac{x}{a}) \right] dx dy \\
 &= \frac{t}{ab} \left[ \frac{E_x \nu_{yx}}{4\lambda} + \frac{G_{xy}}{4} \right] ab \\
 &= \frac{t}{4} \left[ \frac{E_x \nu_{yx}}{\lambda} + G_{xy} \right]
 \end{aligned}$$

and similarly for  $k_{11}$ ,  $k_{13}$ , etc.

The complete stiffness matrix is shown in Fig. B2.

Table 2.1  
 Comparison of Computer Model with Test Data  
 (all data at 50 percent of failure load)

10 x 12 ft Diaphragm					
	Deflection at Jack (in.)	Seam Slip (in.)			
		I	H	G	
Computed values	0.0638	0.0065	0.0065	0.0065	
Actual test	0.0660	0.0080	0.0080	0.0080	
15 x 30 ft Diaphragm					
	Deflection at Jack (in.)	Seam Slip (in.)			
		I	J	K	L
Computed values	0.1762	0.0054	0.0053	0.0053	0.0054
Actual test	0.1900	0.0050	0.0050	0.0050	0.0050

Table 3.1  
 Deflections of Single Story, Single Bay Frames  
 Computed Using Fully Connected Model;  
 Lateral Load Only

Frame	Sheet Thickness	Horiz. Deflection (in.)	Est. Act. Horiz. Defl. (in.)
Light	No infill	1.41	1.41
	20 ga.	0.227	0.331
	16 ga.	0.180	0.262
Medium	No infill	0.556	0.556
	20 ga.	0.173	0.252
	16 ga.	0.140	0.204
Heavy	No infill	0.172	0.172
	20 ga.	0.101	0.147
	16 ga.	0.087	0.127

Table 3.2  
 Shear Distribution in Single Story, Single Bay Frames  
 Computed Using Fully Connected Model;  
 Lateral Load Only

Frame	Sheet Thickness	Shear in Columns (kips)	Shear in Panels (kips)
Light	No infill	100	--
	20 ga.	15.3	84.7
	16 ga.	11.6	88.4
Medium	No infill	100	--
	20 ga.	29.3	70.2
	16 ga.	23.2	76.8
Heavy	No infill	100	--
	20 ga.	57.0	43.0
	16 ga.	48.4	51.6

Table 3.3

Forces on Edge and End Connectors at Maximum Allowable Load on Panel (Maximum Allowable Load = Buckling Load/1.5)

Panel Thickness	Maximum Allowable Panel Load (kips)	Connector Forces @ Max. Allow. Load (max. of 3 frames)	Load on Cont. Fillet Weld (lb./in.)	Nominal Safety Factor
16 ga.	71.5	6.32	211	10.9
20 ga.	32.7	2.90	97	17.7



Table 3.4

Comparison of Horizontal Displacements Calculated Using  
Different Spring Constants for Fasteners

End	Spring Constant (k/in.)		Horizontal Displacement (in.)
	Edge	Seam	
4000.	2000.	500.	0.136
2000.	1000.	500.	0.140
1000.	500.	500.	0.147
2000.	10000.	500.	0.139
2000.	1000.	1000.	0.129
2000.	1000.	400.	0.145
2000.	1000.	100.	0.184

Table 3.5

Forces on Edge Connectors for 16 Gauge Panel, Gravity Plus  
Lateral Load with Different Stiffnesses Assumed for  
Frame-Marginal Member Connection

Spring Constant (k/in)	Connector Force	
	Horizontal (kips)	Vertical (kips)
25.8	9.48	2.74
2.58	7.19	0.39
0.258	6.83	0.072

Table 3.6

Comparison of Results for Exact Model and Corner Model for  
Various Frame Panel Combinations (Lateral Load Only)

Frame	Displacement*	Exact Model	Corner Only Model	% Error
Light 16 ga.	LCH	0.1801	0.1790	0.61
	LCV	0.00266	0.00262	1.50
	LCR	0.00100	0.00101	1.00
	RCH	0.1405	0.1396	0.65
	RCV	-0.00266	-0.00262	1.50
	RCR	0.00049	0.00051	4.00
Light 20 ga.	LCH	0.2266	0.2268	0.18
	LCV	0.00267	0.00265	0.75
	LCR	0.00124	0.00127	2.42
	RCH	0.1869	0.1874	0.27
	RCV	-0.00267	-0.00265	0.75
	RCR	0.00074	0.00077	4.05
Medium 16 ga.	LCH	0.1400	0.1400	--
	LCV	0.00103	0.00102	0.98
	LCR	0.00081	0.00082	1.23
	RCH	0.1166	0.1167	0.09
	RCV	-0.00103	-0.00102	0.98
	RCR	0.00051	0.00052	1.96
Medium 20 ga.	LCH	0.1734	0.1743	0.52
	LCV	0.00103	0.00103	--
	LCR	0.00100	0.00102	2.00
	RCH	0.1500	0.1510	0.66
	RCV	-0.00103	-0.00103	--
	RCR	0.00070	0.00071	1.43

(cont.)

\*LCH = top left corner horizontal displacement (in.).  
 LCV = top left corner vertical displacement (in.).  
 LCH = top left corner rotation (radians).  
 RCH = top right corner horizontal displacement (in.).  
 RCV = top right corner vertical displacement (in.).  
 RCR = top right corner rotation (radians).

Table 3.6 (continued)

Frame	Displacement	Exact Model	Corner Only Model	% Error
Heavy 16 Ga.	LCH	0.0873	0.0876	0.34
	LCV	0.00044	0.00044	--
	LCR	0.00051	0.00051	--
	RCH	0.0760	0.0761	0.13
	RCV	-0.00044	-0.00044	--
	RCR	0.00036	0.00036	--
Heavy 20 ga.	LCH	0.1011	0.1018	0.69
	LCV	0.00044	0.00044	--
	LCR	0.00058	0.00059	1.72
	RCH	0.0897	0.0902	0.56
	RCV	-0.00044	-0.00044	--
	RCR	0.00044	0.00044	--

Table 3.7

Comparison of Results for Exact Model and Corner-Only Model  
for Various Frame Panel Combinations  
(Lateral plus Gravity Load)

Frame	Displacement*	Exact Model	Corner-Only Model	% Error
Light 16 ga.	LCH	0.2069	0.2049	0.97
	LCV	-0.1349	-0.1332	1.26
	LCR	0.00161	0.00255	58.4
	RCH	0.1405	0.1401	0.29
	RCV	-0.1402	-0.1385	1.21
	RCR	-0.00012	-0.00103	759.
Medium 16 ga.	LCH	0.1557	0.1554	0.19
	LCV	-0.0521	-0.0519	0.38
	LCR	0.00118	0.00136	15.2
	RCH	0.1166	0.1166	-
	RCV	-0.0542	-0.0539	0.55
	RCR	0.00014	-0.00024	272.
Heavy 20 ga.	LCH	0.0950	0.0951	0.11
	LCV	-0.0225	-0.0225	-
	LCR	0.00067	0.00069	3.00
	RCH	0.0760	0.0761	0.13
	RCV	-0.0234	-0.0234	-
	RCR	0.00020	0.00018	10.0

\*See note to Table 3.6.

Table 3.8

Buckling Loads for 3" and 1½" Deep Corrugated Sections of  
Various Gauges for Infill 10½' by 30' (see Fig. 3.11  
for deck configurations)

Depth	Gauge				
	12	14	16	18	20
1½"	248 <sup>k</sup>	148 <sup>k</sup>	107 <sup>k</sup>	70 <sup>k</sup>	49 <sup>k</sup>
3"	785 <sup>k</sup>	475 <sup>k</sup>	336 <sup>k</sup>	242 <sup>k</sup>	158 <sup>k</sup>

Table 4.1

Shear Distribution for 26 Story Frame with  
16 ga. Infills on all Floors

Story (1)	Column Shear		Panel Shear (kips) (4)	% of Shear in Panels (5)	Buckling Load (kips) (6)	Nominal Safety Factor (7)
	Exterior (kips) (2)	Interior (kips) (3)				
26	3.5	1.3	0.6	11	107.0	178
25	3.8	1.5	7.2	51	↓	14.9
24	5.9	5.2	8.7	44		12.3
23	5.9	5.5	15.7	58		6.8
22	8.6	8.6	17.0	50		6.3
21	9.6	9.7	22.1	53		4.8
20	12.2	13.9	22.5	46		4.8
19	13.3	15.1	27.4	49		3.9
18	14.6	18.0	31.4	50		3.4
17	15.2	19.1	35.9	51		3.0
16	17.1	22.6	37.7	49		2.8
15	18.5	24.4	41.7	49		2.6
14	19.4	27.2	45.2	49		2.4
13	20.1	28.4	50.5	51		2.2
12	21.9	32.0	52.3	49		2.0
11	23.1	34.2	56.1	50		1.9
10	24.0	36.6	60.0	50		1.8
9	24.6	37.9	65.3	51		1.6
8	26.5	42.8	65.7	49		1.6
7	28.3	45.6	68.3	48		1.6
6	29.8	49.8	69.8	47		1.5
5	31.0	53.7	71.9	46		1.5
4	31.5	55.7	76.5	47		1.4
3	32.2	57.4	81.4	48		1.3
2	35.5	64.0	78.6	44		1.4
1	50.8	84.6	50.0	27		107.0

Table 4.2

Shear Distribution for 26 Story Frame with  
12 ga. Infills on all Floors

Story (1)	Column Shear		Panel Shear (kips) (4)	% of Shear in Panels (5)	Buckling Load (kips) (6)	Nominal Safety Factor (7)
	Exterior (kips) (2)	Interior (kips) (3)				
26	3.9	1.4	0.1	2	187.0	1870
25	4.0	1.5	7.1	56	↓ 187.0	26.4
24	6.3	5.2	8.3	42		22.6
23	5.9	5.2	15.9	59		27.0
22	8.8	8.1	17.3	51		12.2
21	9.5	8.8	23.1	56		8.1
20	12.3	12.7	23.6	49		7.9
19	13.0	13.6	29.2	52		6.4
18	14.3	16.2	32.5	52		5.8
17	14.6	16.7	38.9	55		4.8
16	16.4	19.9	41.1	53		4.6
15	17.6	21.2	45.8	54		4.1
14	18.3	23.5	50.0	55		3.7
13	18.6	24.1	56.3	57		3.3
12	20.3	27.3	58.6	55		3.2
11	21.2	28.9	62.3	55		3.0
10	21.8	30.7	68.1	57		2.7
9	21.9	31.4	74.5	58		2.5
8	23.6	35.7	75.7	56		2.5
7	24.9	37.8	79.5	56		2.4
6	26.1	41.3	82.0	55		2.3
5	26.9	43.4	86.3	55		2.2
4	26.9	45.6	91.3	56		2.1
3	26.6	46.4	98.0	57		1.9
2	29.4	57.6	106.2	60		1.8
1	45.0	75.2	65.1	35		187.0

Table 4.3

Shear Distribution for 26 Story Frame with  
20 ga. Infills on all Floors

Story (1)	Column Shear		Panel Shear (kips) (4)	% of Shear in Panels (5)	Buckling Load (kips) (6)	Nominal Safety Factor (7)	
	Exterior (kips) (2)	Interior (kips) (3)					
26	3.0	1.2	1.2	22	49.0	40.8	
25	3.6	1.6	7.4	59	↓	6.6	
24	5.5	5.4	8.9	45		5.5	
23	5.9	7.1	14.0	52		3.5	
22	8.5	9.5	16.2	47		3.0	
21	9.8	11.0	20.6	50		2.4	
20	12.2	15.4	20.9	43		2.3	
19	13.6	17.2	25.0	45		2.0	
18	15.0	20.5	27.5	44		1.8	
17	16.1	22.0	32.1	46		1.5	
16	18.0	26.0	33.4	43		1.5	
15	19.7	29.3	35.6	42		1.4	
14	20.7	31.6	39.5	43		1.2	
13	21.9	33.4	43.7	44		1.1	
12	23.7	37.5	45.0	42		1.1	
11	25.2	40.3	47.9	42		1.0	
10	26.4	43.2	51.0	42		1.0	
9	27.7	45.2	54.9	43		0.9	
8	29.5	50.7	54.8	41		0.9	
7	31.8	54.0	56.4	40		0.9	
6	33.5	58.9	57.0	38		0.9	
5	35.2	62.4	59.0	38		0.8	
4	36.2	66.1	61.5	38		0.8	
3	37.8	68.5	67.7	40		0.7	
2	41.3	75.9	61.0	34		49.0	0.8
1	55.6	92.5	37.0	20		49.0	1.3

Table 4.4

Comparison of Actual and Predicted Deflections for 26 Story Frame with 16 ga. Infills Full Height; Panel Stiffnesses Chosen to Get Drift of .288" at Ninth Floor; Shortening of Interior Columns not Suppressed

Story (1)	Drift (in.) (2)	Total Shear (kips) (3)	$V_F$ (pred.) (kips) (4)	$V_F$ (act.) (kips) (5)	$V_P$ (pred.) (kips) (6)	$V_P$ (act.) (kips) (7)	% Error in $V_P$ (8)	Drift (pred.) (in.) (9)	Drift (act.) (in.) (10)
26	0.20	5.4	3.2	4.4	2.2	1.0	+120	0.118	0.139
25	0.32	12.6	7.4	8.8	5.2	3.8	+36.8	0.190	0.220
24	0.28	19.8	11.6	14.3	8.2	5.5	+49.1	0.165	0.196
23	0.35	27.0	15.9	18.5	11.1	8.5	+30.6	0.206	0.240
22	0.33	34.2	20.1	23.6	14.1	10.6	+33.0	0.194	0.230
21	0.36	41.4	24.3	28.0	17.1	13.4	+27.6	0.212	0.247
20	0.34	48.6	28.6	33.4	20.0	15.2	+31.6	0.200	0.233
19	0.36	55.8	32.8	37.6	23.0	18.2	+26.4	0.212	0.246
18	0.37	63.0	37.0	42.2	26.0	20.8	+25.0	0.218	0.253
17	0.40	70.2	41.2	46.1	29.0	24.1	+20.4	0.235	0.270
16	0.41	77.4	45.4	51.4	26.0	23.1	+23.1	0.241	0.269
15	0.41	84.6	49.7	54.9	34.9	29.7	+17.5	0.241	0.269
14	0.43	91.8	53.9	59.7	37.9	32.1	+18.1	0.253	0.281
13	0.45	99.0	58.1	63.2	40.9	35.8	+14.2	0.264	0.294
12	0.45	106.2	62.5	68.1	43.7	38.1	+14.7	0.264	0.289
11	0.46	113.4	66.6	72.2	46.7	41.2	+13.3	0.270	0.293
10	0.46	120.6	70.9	75.3	49.7	45.3	+9.7	0.270	0.296
9	0.49	127.8	75.0	80.0	52.8	47.8	+10.5	0.288	0.304
8	0.46	135.0	79.4	83.6	55.6	50.6	+9.8	0.270	0.288
7	0.45	142.2	83.6	87.4	58.6	57.8	+1.4	0.264	0.280
6	0.44	149.4	87.8	91.9	61.6	57.5	+7.1	0.259	0.270
5	0.43	156.6	92.0	94.6	64.6	62.0	+4.2	0.252	0.262
4	0.43	163.8	96.2	97.9	67.6	65.9	+2.6	0.252	0.260
3	0.43	171.0	100.5	101.0	70.5	70.0	+0.7	0.252	0.255
2	0.38	178.2	104.9	105.6	73.3	72.6	+1.0	0.224	0.223
1	0.20	185.4	109.0	107.0	76.4	78.4	-2.6	0.118	0.121



Table 4.5

Comparison of Actual and Predicted Deflections for 26 Story Frame Infilled Full Height; Panel Stiffnesses Chosen to Get Drift of .288" at Ninth Floor; Interior Column Shortening Suppressed

Story	Drift (act.) (in.)	Drift (pred.) (in.)	% Error	Panel Shear (act.) (kips)	Panel Shear (pred.) (kips)	% Error
(1)	(2)	(3)	(4)	(5)	(6)	(7)
26	0.120	0.118	-1.7	2.1	2.2	+4.8
25	0.191	0.190	-0.5	5.2	5.2	-
24	0.164	0.165	+0.6	8.0	8.2	+2.5
23	0.205	0.206	-0.5	11.0	11.1	+0.9
22	0.196	0.194	-1.0	14.0	14.1	-
21	0.212	0.212	0.0	17.1	17.1	-
20	0.199	0.200	+0.5	19.8	20.0	+1.0
19	0.212	0.212	0.0	23.1	23.0	-0.4
18	0.219	0.218	-0.5	26.1	26.0	-0.4
17	0.235	0.235	0.0	29.4	29.0	-1.4
16	0.237	0.241	+1.7	31.6	32.0	+1.3
15	0.242	0.241	-0.4	35.6	34.9	-2.0
14	0.251	0.253	+0.8	38.0	37.9	-0.3
13	0.263	0.264	+0.4	41.6	40.9	-1.7
12	0.261	0.264	+1.2	44.2	43.7	-1.1
11	0.266	0.270	+1.5	47.0	46.7	-0.6
10	0.271	0.270	-0.4	51.2	49.7	-2.9
9	0.281	0.288	+2.5	53.2	52.8	-0.8
8	0.267	0.270	+1.1	56.9	55.6	-2.3
7	0.262	0.264	+0.8	60.1	58.6	-2.5
6	0.253	0.259	+2.3	62.5	61.6	-1.4
5	0.249	0.252	+1.2	66.5	64.6	-2.9
4	0.248	0.252	+1.6	69.4	67.6	-2.6
3	0.248	0.252	+1.6	72.7	70.5	-3.0
2	0.218	0.224	+1.8	74.5	73.3	-1.6
1	0.119	0.118	-0.8	79.6	76.4	-4.0

Table 4.6

26 Story Frame with 16 ga. Infills Full Height--Calculations  
to Choose Panel Stiffnesses to Give Drift Less than  
or Equal to 1/500th of Story Height

Story (1)	Drift (unreduced) (in.) (2)	Drift (pred.) (in.) (3)	Total Shear (kips) (4)	Frame Shear (pred.) (kips) (5)	Panel Shear (pred.) (kips) (6)
26	0.20	0.180	5.4	4.9	0.5
25	0.32	0.288	12.6	11.3	1.3
24	0.28	0.252	19.8	17.8	2.0
23	0.35	0.288	27.0	22.2	4.8
22	0.33		34.2	29.8	4.4
21	0.36		41.4	33.1	8.3
20	0.34		48.6	41.2	7.4
19	0.36		55.8	44.6	11.2
18	0.37		63.0	49.0	14.0
17	0.40		70.2	50.6	19.6
16	0.41		77.4	54.3	23.1
15	0.41		84.6	59.5	25.1
14	0.43		91.8	61.4	30.4
13	0.45		99.0	63.4	35.6
12	0.45		106.2	68.0	38.2
11	0.46		113.4	71.0	42.4
10	0.46		120.6	75.5	45.1
9	0.49		127.8	75.0	52.8
8	0.46		135.0	84.5	50.5
7	0.45		142.2	91.1	51.1
6	0.44		149.4	97.8	51.6
5	0.43		156.6	104.8	51.8
4	0.43		163.8	109.5	54.3
3	0.43		171.0	114.5	56.5
2	0.38	0.288	178.2	135.2	43.0
1	0.20	0.180	185.4	167.0	18.4

Table 4.7

Comparison of Actual and Predicted Deflections for 26 Story  
 Frame with 16 ga. Infills Full Height; Panel Stiffnesses  
 Chosen to Get Drift of .288" or Less at All Floors;  
 Interior Column Shortening Suppressed

Story (1)	Drift (act.) (in.) (2)	Drift (pred.) (in.) (3)	% Error (4)	Panel Shear (act.) (kips) (5)	Panel Shear (pred.) (kips) (6)	% Error (7)
26	0.172	0.180	+4.7	0.5	0.5	-
25	0.282	0.288	+2.1	1.3	1.3	-
24	0.236	0.252	+6.4	1.9	2.0	+5.3
23	0.283	0.288	+1.8	4.9	4.8	-2.0
22	0.276		+4.4	4.3	4.4	+2.3
21	0.288		-	8.5	8.3	-2.4
20	0.273		+5.5	7.2	7.4	+2.8
19	0.283		+1.8	11.5	11.2	-2.6
18	0.282		+2.1	14.1	14.0	-0.7
17	0.291		-1.0	20.3	19.6	-3.5
16	0.282		+2.1	23.2	23.1	-0.4
15	0.286		+0.7	25.7	25.1	-2.3
14	0.285		+1.1	30.9	30.4	-1.6
13	0.290		-0.7	37.0	35.6	-3.8
12	0.285		+1.1	38.8	38.2	-1.5
11	0.284		+1.4	43.3	42.4	-2.1
10	0.286		+0.7	46.4	45.1	-2.3
9	0.290		-0.7	54.9	52.8	-3.8
8	0.284		+1.4	51.7	50.5	-2.3
7	0.285		+1.1	52.7	51.1	-3.0
6	0.283		+1.8	52.7	51.6	-2.1
5	0.283		+1.8	53.3	51.8	-2.8
4	0.285		+1.1	56.4	54.3	-3.7
3	0.294		-2.1	60.5	56.5	-6.6
2	0.282	0.288	+2.1	44.1	43.0	-2.5
1	0.168	0.180	+7.1	18.2	18.4	+1.1

Table 4.8

26 Story Frame with 16 ga. Infills Full Height--Calculations  
to Choose Panel Stiffnesses to Give Drift Less Than  
or Equal to 1/500th of Story Height

Story (1)	Drift (unreduced) (in.) (2)	Shear Drift (pred.) (in.) (3)	Total Shear (kips) (4)	Frame Shear (pred.) (kips) (5)	Panel Shear (pred.) (kips) (6)
26	0.20	0.189	5.4	5.1	0.3
25	0.32	0.264	12.6	10.4	2.2
24	0.28		19.8	18.7	1.1
23	0.35		27.0	20.4	6.6
22	0.33		34.2	27.4	6.8
21	0.36		41.4	30.4	11.0
20	0.34		48.6	37.7	10.9
19	0.36		55.8	40.9	14.9
18	0.37		63.0	44.9	18.1
17	0.40		70.2	46.3	23.9
16	0.41		77.4	49.8	27.6
15	0.41		84.6	54.5	30.1
14	0.43		91.8	56.3	35.5
13	0.45		99.0	58.0	41.0
12	0.45		106.2	62.4	43.8
11	0.46		113.4	65.1	48.3
10	0.46		120.6	69.2	51.4
9	0.49		127.8	68.3	59.5
8	0.46		135.0	77.6	57.4
7	0.45		142.2	83.0	59.2
6	0.44		149.4	89.8	59.6
5	0.43		156.6	96.7	60.5
4	0.43		163.8	100.7	63.1
3	0.43		171.0	105.0	66.0
2	0.38	0.264	178.2	123.9	54.3
1	0.20	0.189	185.4	175.0	10.4

Table 4.9

Comparison of Actual and Predicted Deflections for 26 Story Frame with 16 ga. Infills Full Height; Panel Stiffnesses Chosen to Get Drift of .288" or Less at All Floors; Interior Column Shortening Included

Story (1)	Drift (act.) (in.) (2)	Total Drift (pred.) (in.) (3)	% Error (4)	Panel Shear (act.) (kips) (5)	Panel Shear (pred.) (kips) (6)	% Error (7)
26	0.168	0.213	+26.8	0.2	0.3	+50.0
25	0.270	0.288	+6.3	1.7	2.2	+29.4
24	0.245		+17.6	0.7	1.1	+57.1
23	0.283		+1.8	5.4	6.6	+22.2
22	0.271		+6.3	5.3	6.8	+28.4
21	0.285		+1.1	9.2	11.0	+19.6
20	0.270		+6.7	8.4	10.9	+29.8
19	0.282		+2.1	12.2	14.9	+22.2
18	0.281		+2.5	14.3	18.1	+26.6
17	0.292		-1.4	20.8	23.9	+14.9
16	0.285		+1.1	23.0	27.6	+20.0
15	0.289		-0.3	26.0	30.1	+15.8
14	0.288		-	30.7	35.5	+15.6
13	0.294		-2.0	36.8	41.0	+11.4
12	0.287		+0.3	38.7	43.8	+13.2
11	0.287		+0.3	43.3	48.3	+11.5
10	0.288		-	46.3	51.4	+10.8
9	0.289		-0.3	55.7	59.5	+6.8
8	0.280		+2.9	53.1	57.4	+8.1
7	0.279		+3.2	55.6	59.2	+6.5
6	0.273		+5.5	56.0	59.6	+6.4
5	0.272		+5.9	58.1	60.5	+4.1
4	0.271		+6.3	62.0	63.1	+1.8
3	0.277		+4.0	63.8	66.0	+3.5
2	0.269	0.288	+7.1	55.5	54.3	+2.2
1	0.168	0.213	+26.8	9.7	10.4	+7.2

Table A1

Common Blocks and the Subroutines They are Required in.

Block	Subroutine												
	M A I N	C O D E S T	P L A T E	B E A M	C O L U M	M A T M U L	E L M A K	S I M O N	M I N V	R E L E M E M	F O R C E	F O R C E 1	S T I G E N
BLK 1	X	X	X	X	X	X	*	*	X	X	X	X	*
BLK 10	*	*	X	X	X	X	*	*	X	X	*	X	*
BLK 11	*	*	X	X	X	X	*	*	X	*	X	*	*
BLK 12	*	*	X	X	X	X	*	*	X	*	*	X	*
BLK 13	*	*	X	X	X	X	*	*	X	X	X	X	*
BLK 14	*	*	X	X	X	X	*	*	X	*	X	X	*
BLK 15	*	*	X	*	X	X	*	*	X	X	*	*	*
BLK 16	X	X	X	X	X	X	*	*	X	X	X	*	*
BLK 20	X	X	X	*	X	X	*	X	X	X	X	X	X
BLK 30	X	X	X	X	X	X	*	X	X	X	X	X	*
BLK 31	*	X	X	X	X	X	*	X	X	X	*	*	*
BLK 32	*	X	X	X	X	X	X	X	X	X	X	X	*
BLK 50	X	X	X	X	X	*	X	X	X	X	*	*	X
BLK 53	X	X	X	X	X	X	*	X	X	X	X	*	X
BLK 81	*	X	X	X	X	X	*	*	X	X	X	X	*
BLK 82	*	X	X	X	X	X	*	X	X	X	*	X	*
BLK 91	X	X	X	X	X	X	X	*	X	X	X	X	X

Symbols: \* - Indicates that the common block is required in the subroutine.

X - Indicates that the common block is not required in the subroutine.

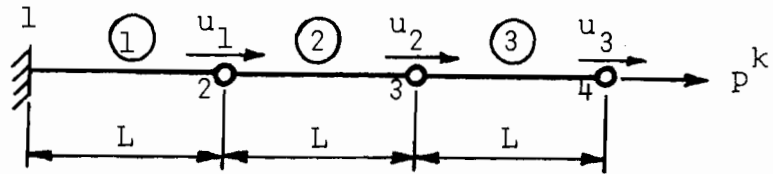

Area of all members =  $A \text{ in}^2$

Elastic Modulus of all members =  $E \text{ k/in}^2$

Fig. 2.1 - Cantilever for wavefront processing example

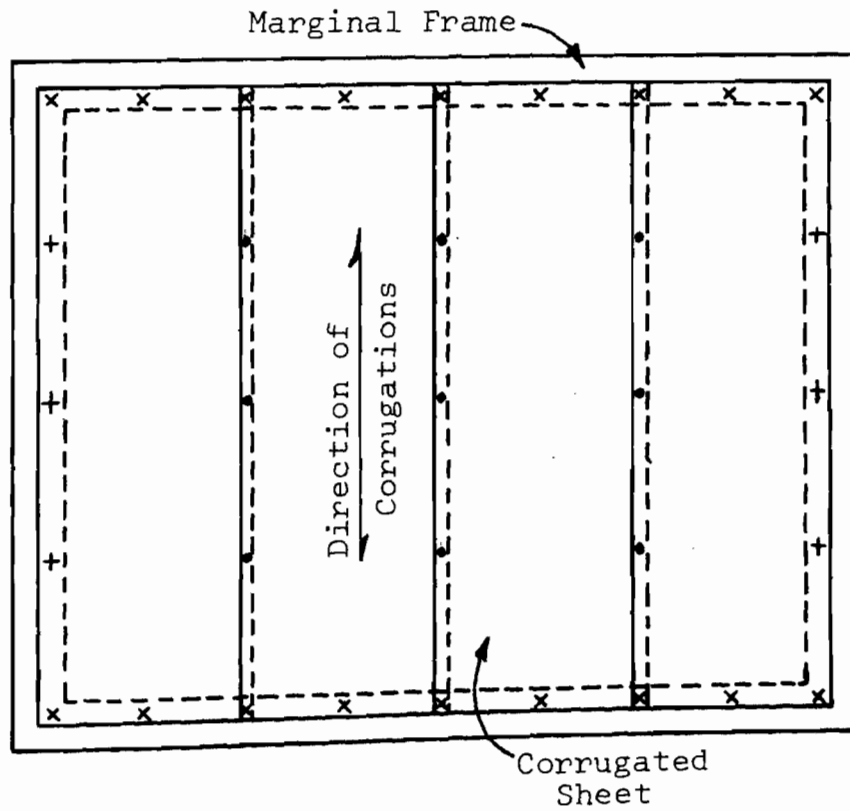

- x = End connector
- + = Edge connector
- = Seam connector

Fig. 2.2 - Construction of a light gauge steel diaphragm



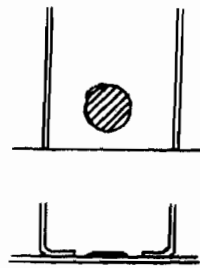

(a) Puddle Weld

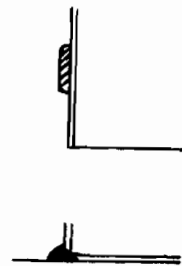

(b) Edge Fillet Weld

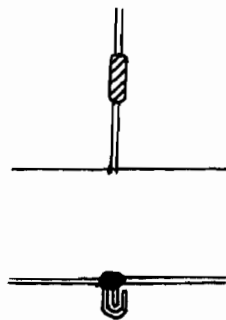

(c) Seam Fillet Weld

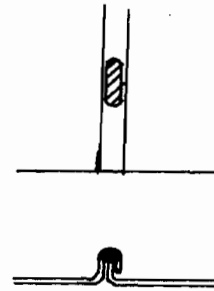

(d) Seam Puddle Weld

Fig. 2.3 - Welded connections for light gauge diaphragms

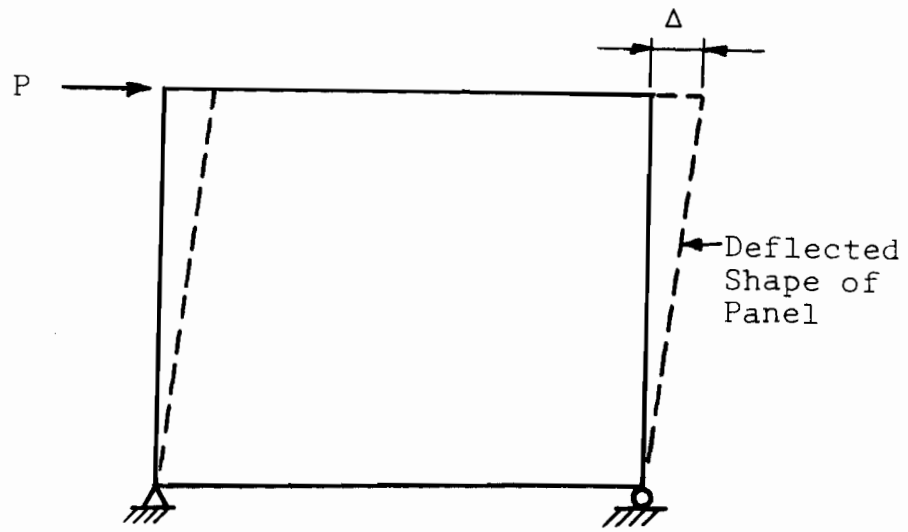

Fig. 2.4 - Shear displacement of a diaphragm



(a) Cellular profile



(b) Open, trapezoidal profile

Fig. 3.1 - Light gauge panel configurations

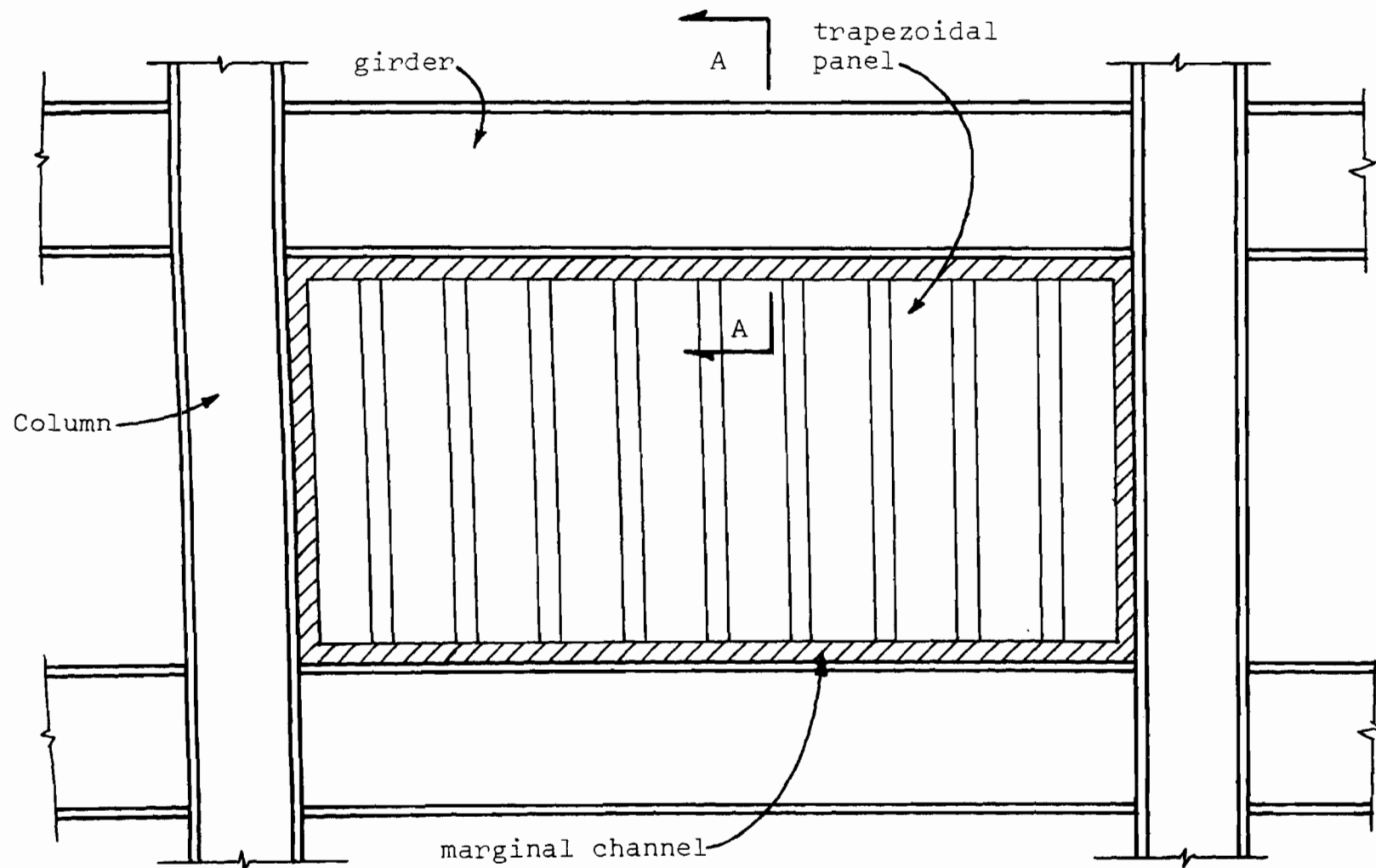

(a) Schematic of proposed construction

Fig. 3.2 - Proposed construction for infilled frames

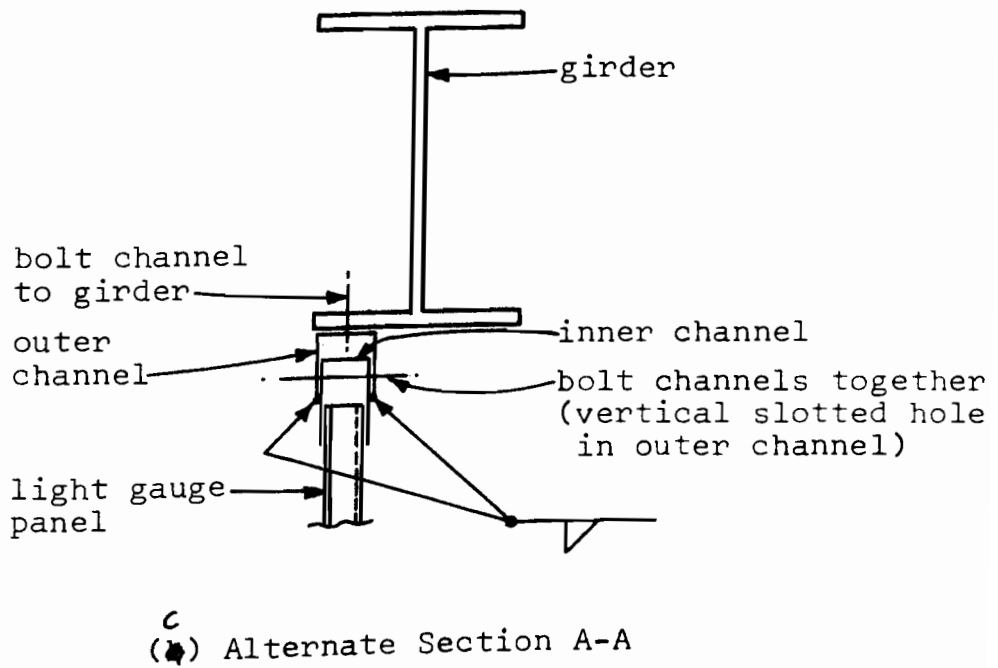
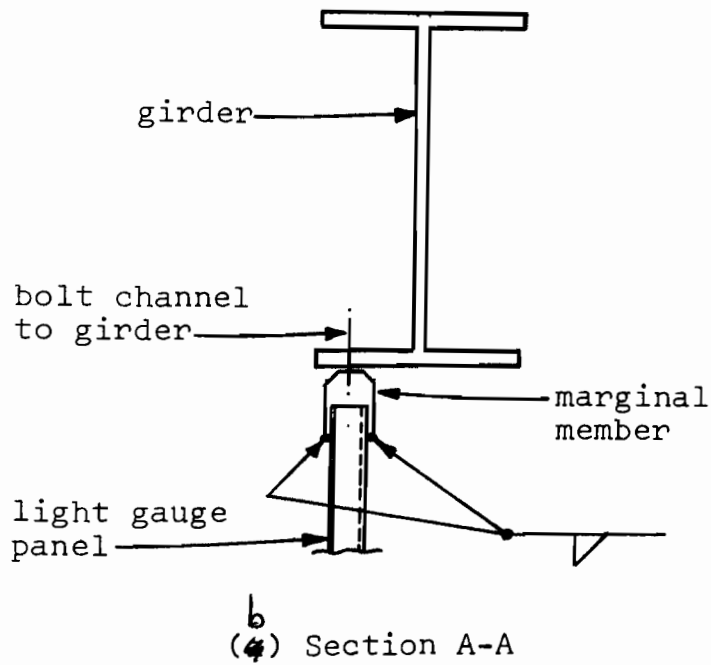
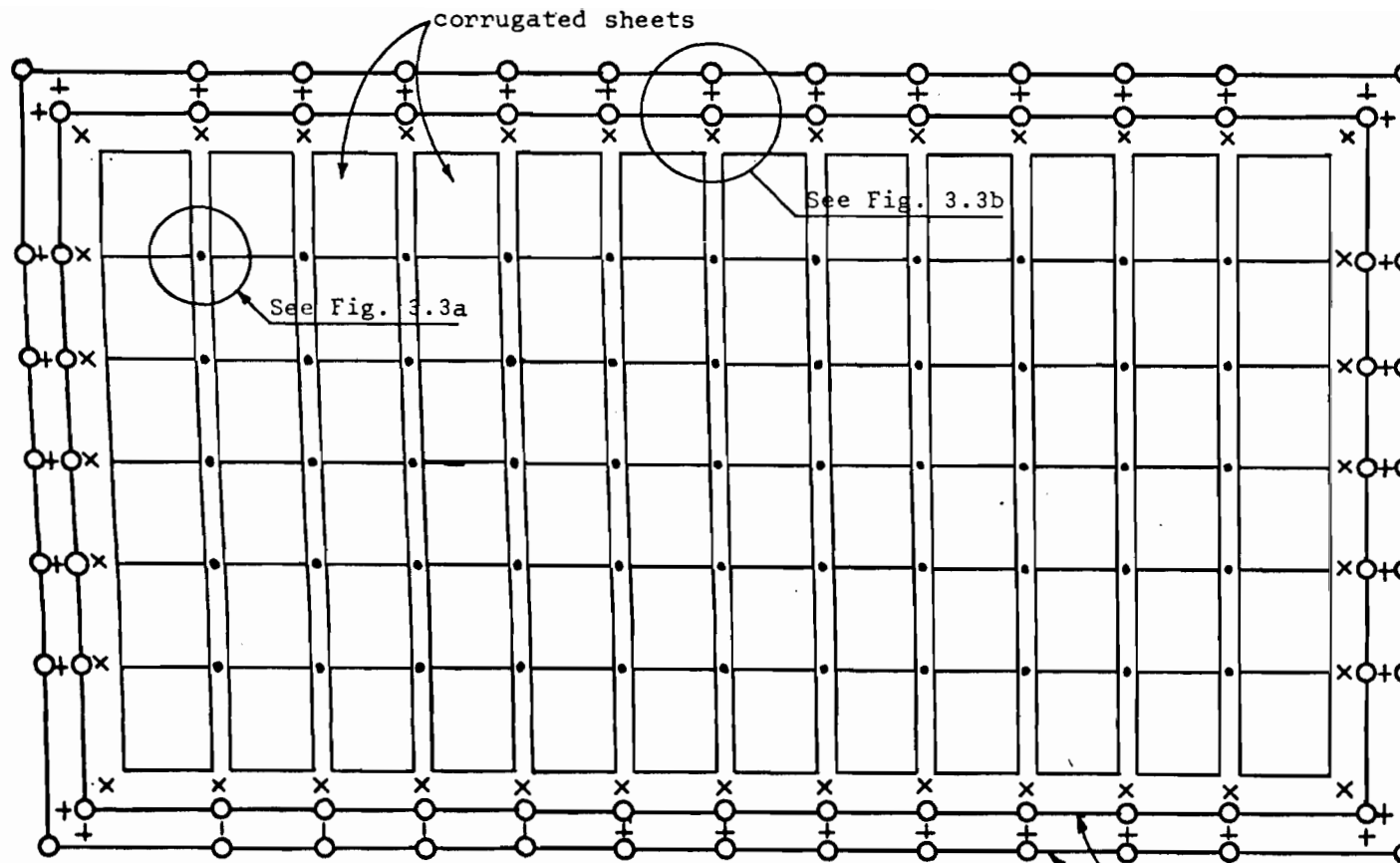

Fig. 3.2 - Proposed construction for infilled frames (cont.)



Symbols:

○ nodal point

× edge or end connector

+ marginal member to frame  
member flexible link

• seam connector

(a) panel idealization

Fig. 3.3 - Idealization of fully connected model

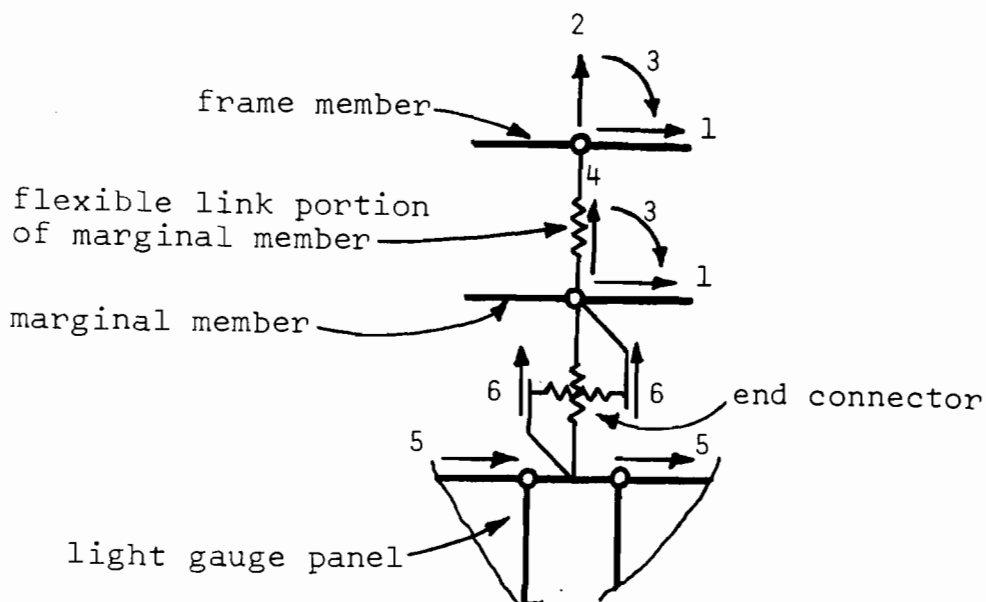

(b) Degrees of freedom at connection of frame and panel for fully connected model

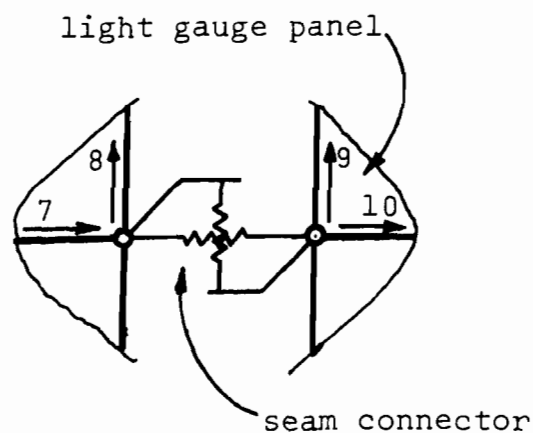

(c) Degrees of freedom at seam connection for fully connected model

Fig. 3.3 - Idealization for fully connected model of the infilled frame

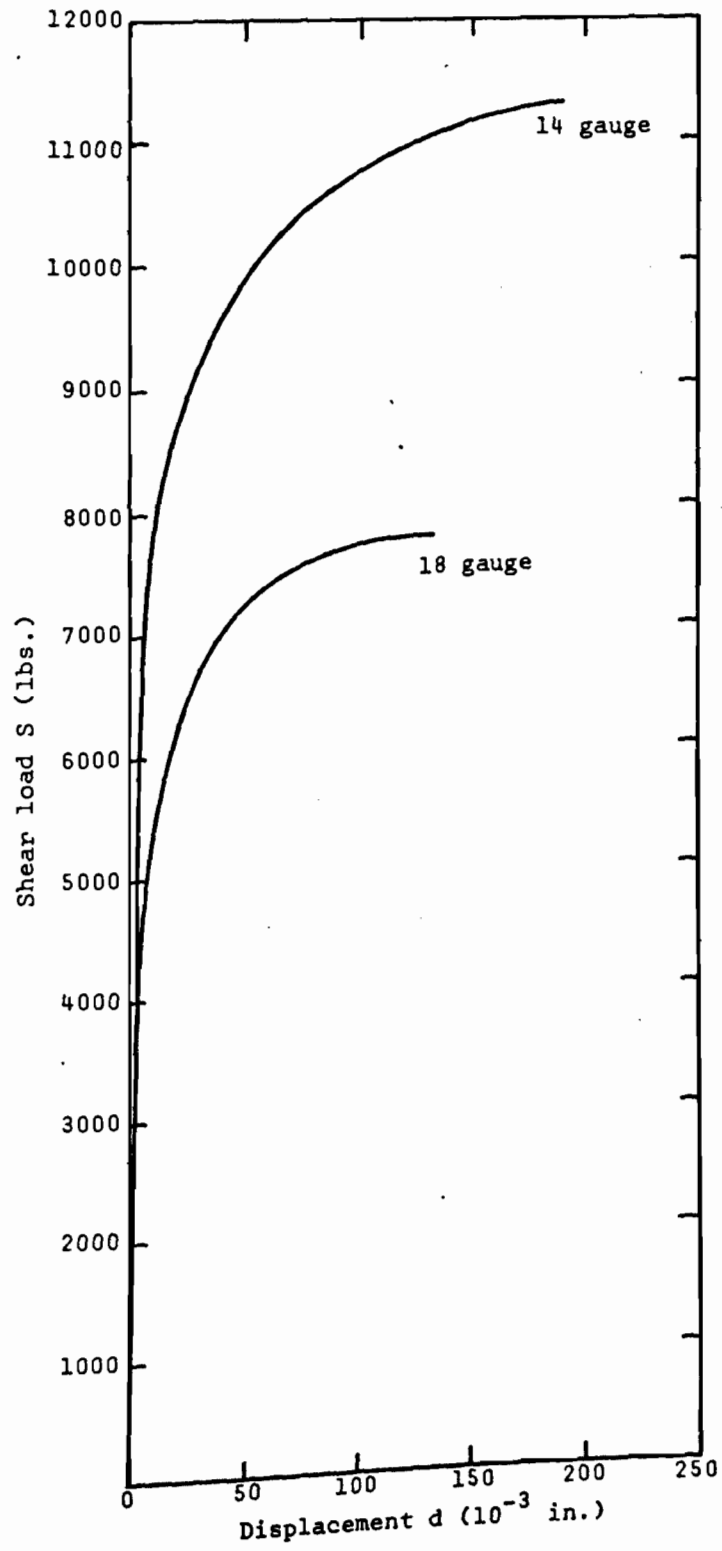

Fig. 3.4 - Load vs. slip for welded sidelap connections



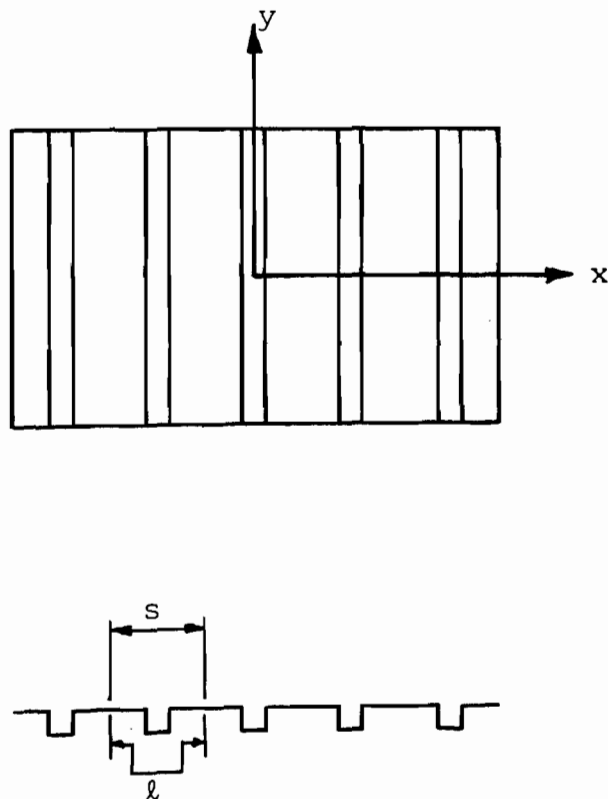

Fig. 3.5 - Coordinate directions for sheet properties

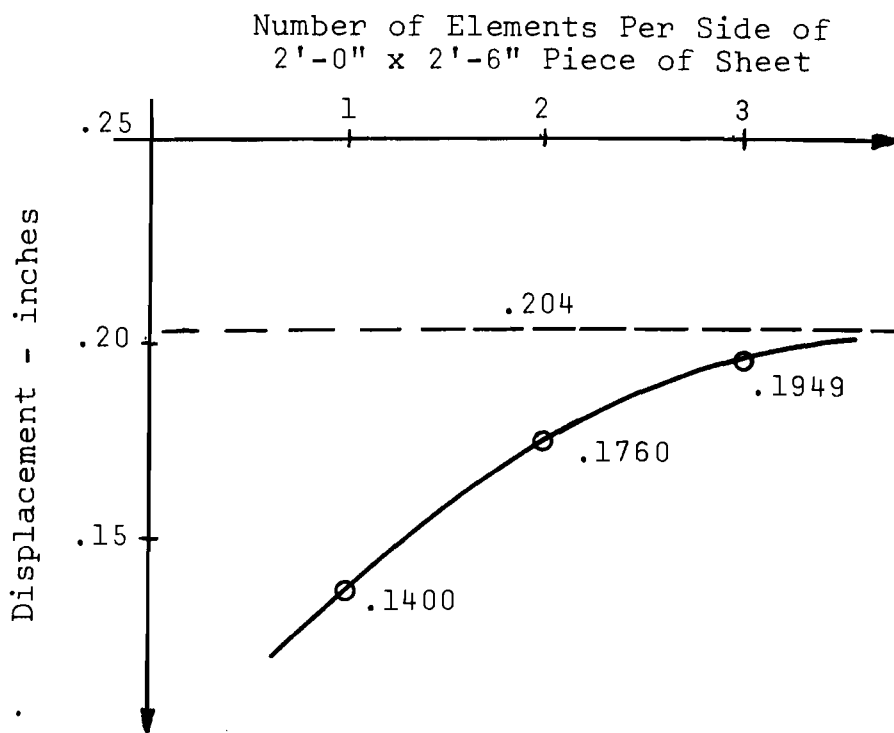

Fig. 3.6 - Convergence curve for single story, single bay infilled frames

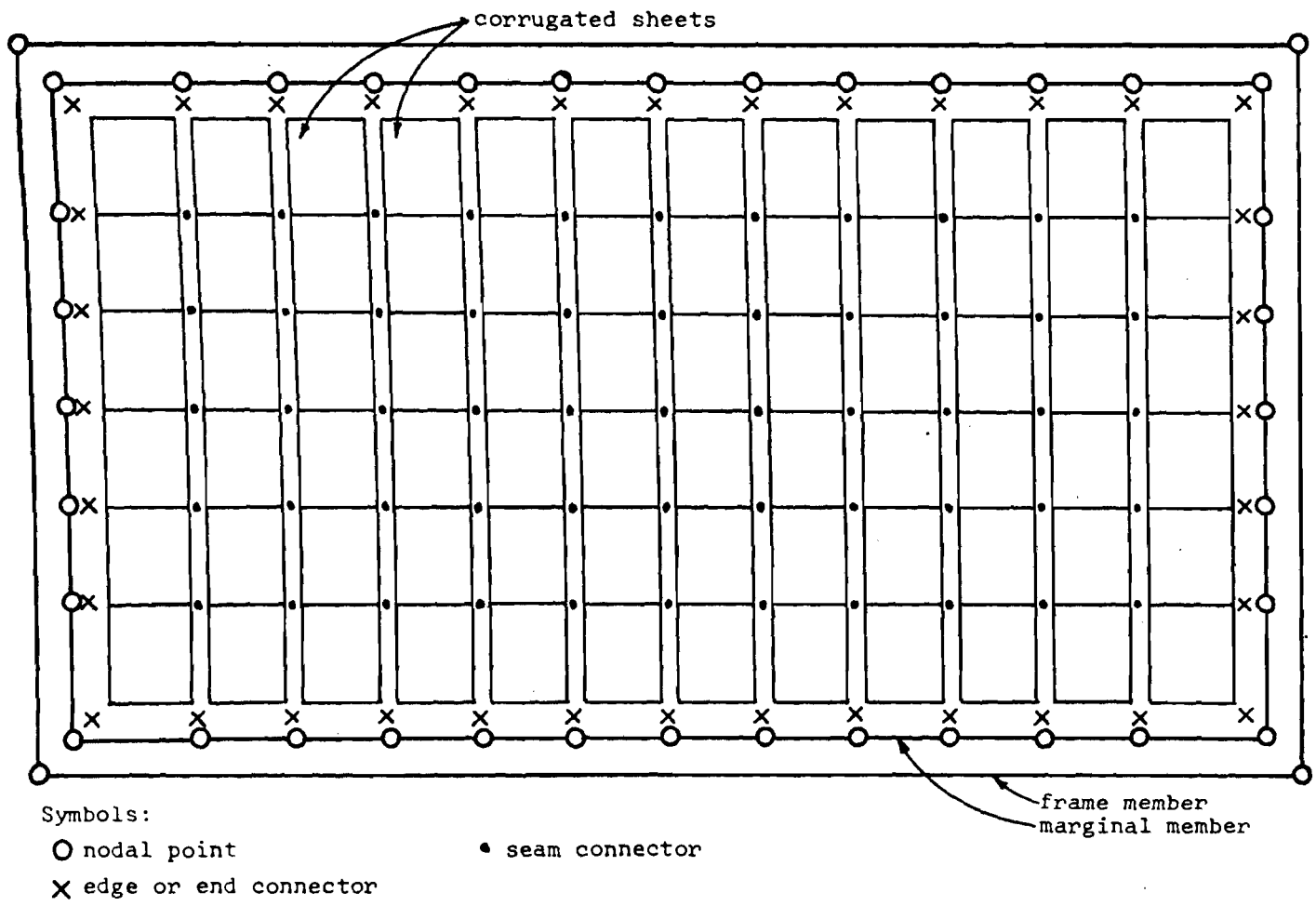

Fig. 3.7 - Idealization of corner only model

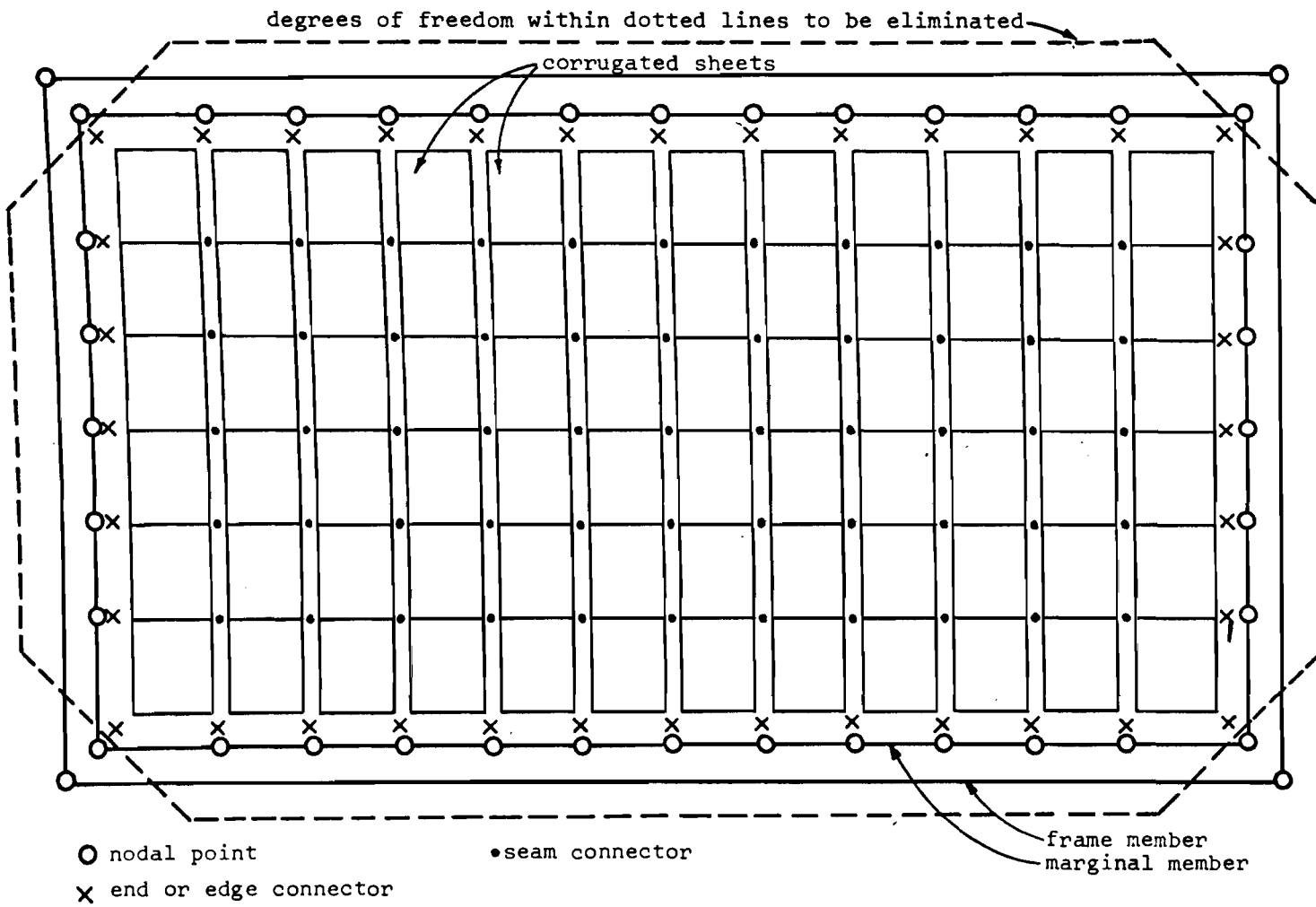
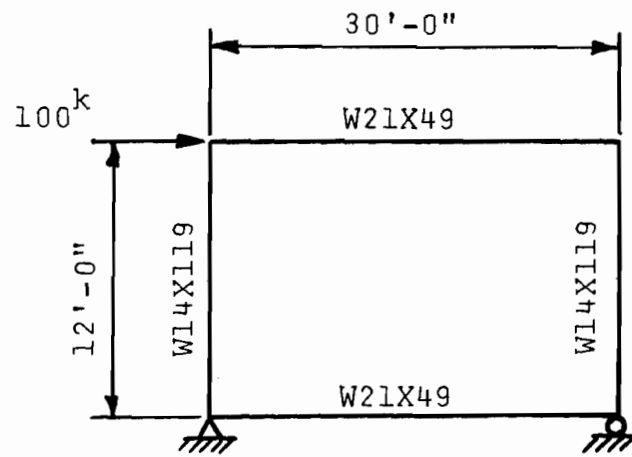
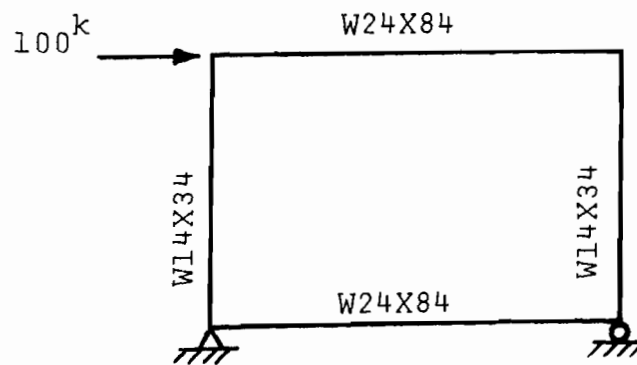

Fig. 3.8 - Degrees of freedom to be eliminated



Light Frame



Medium Frame

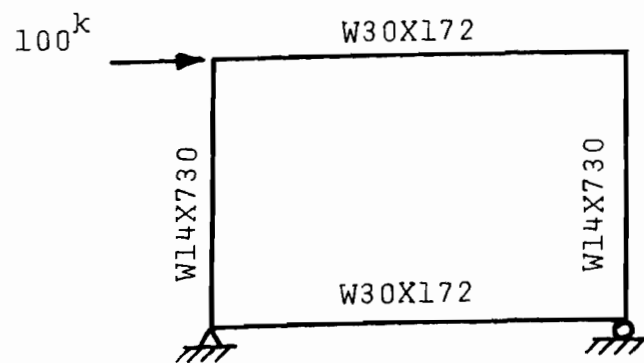

Heavy Frame

Fig. 3.9 - Frames used in Single Story, Single Bay Studies

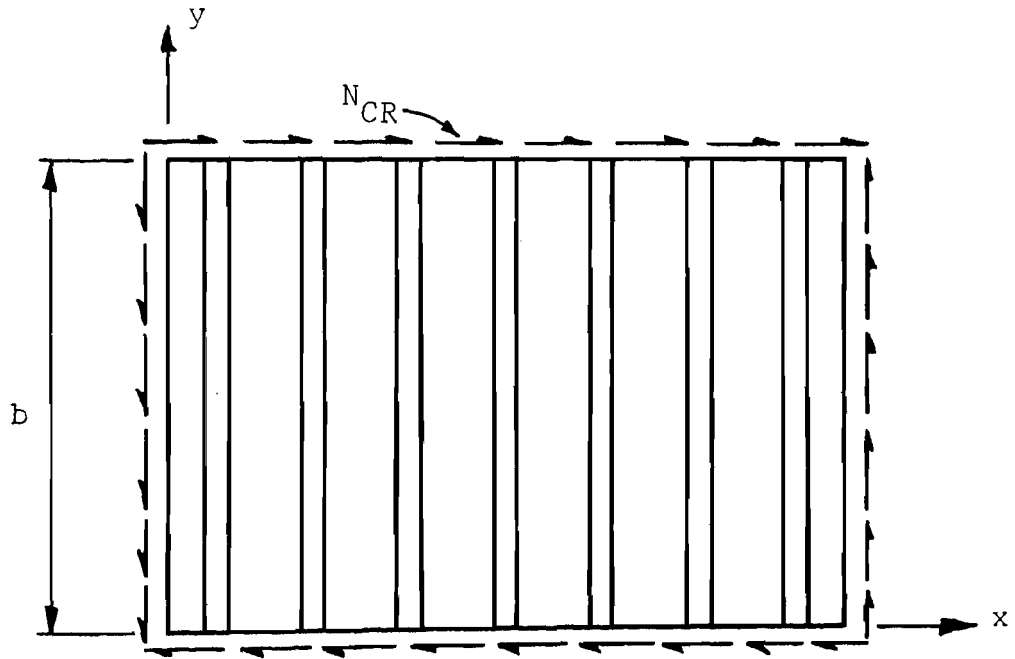
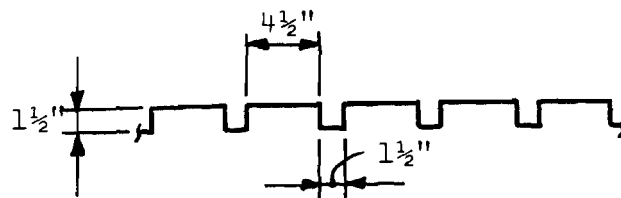
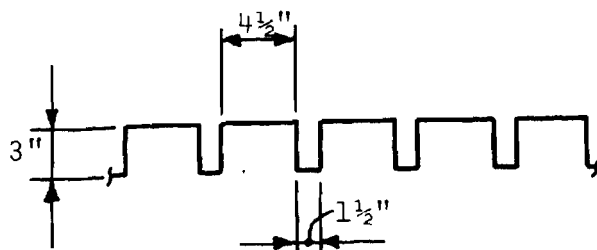

Fig. 3.10 - Coordinate system for panel buckling



(a)  $1\frac{1}{2}$ " Section



(b) 3" Section

Fig. 3.11 - Profiles used to calculate buckling loads

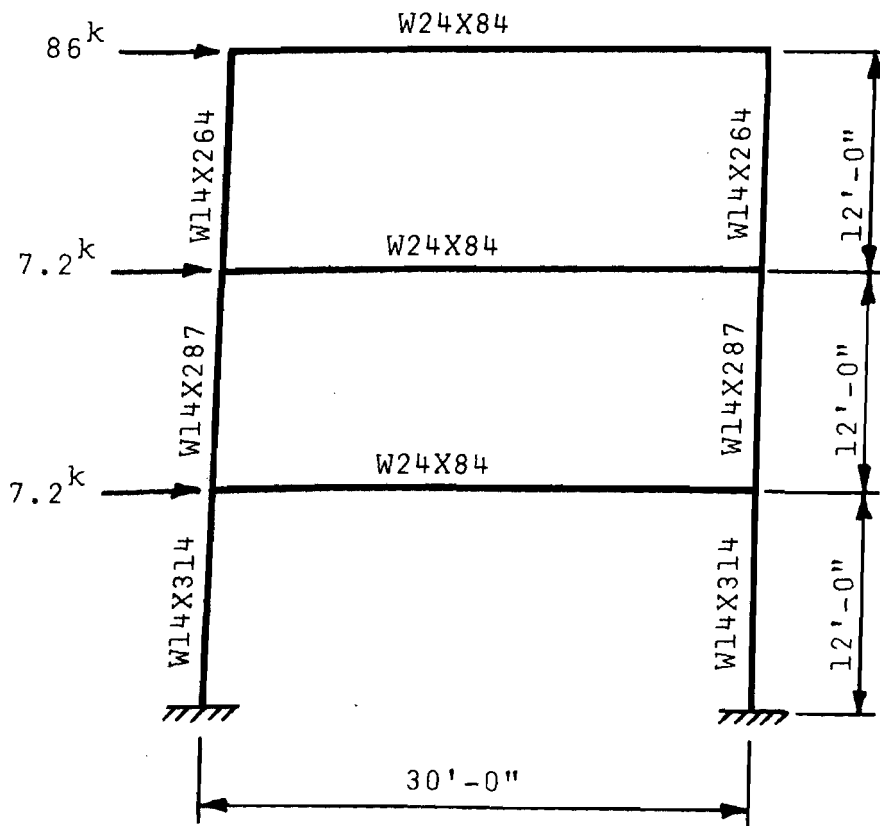
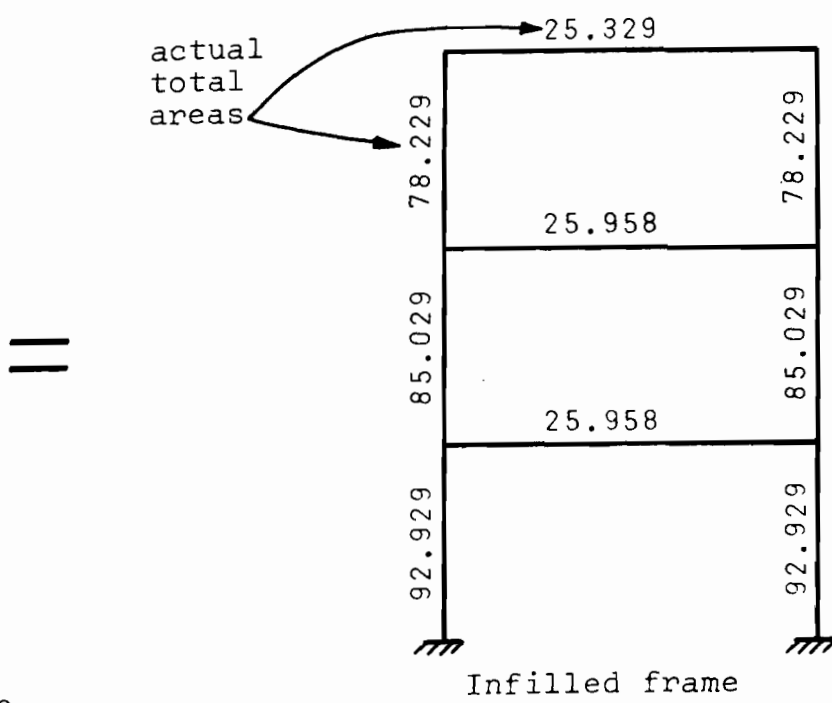
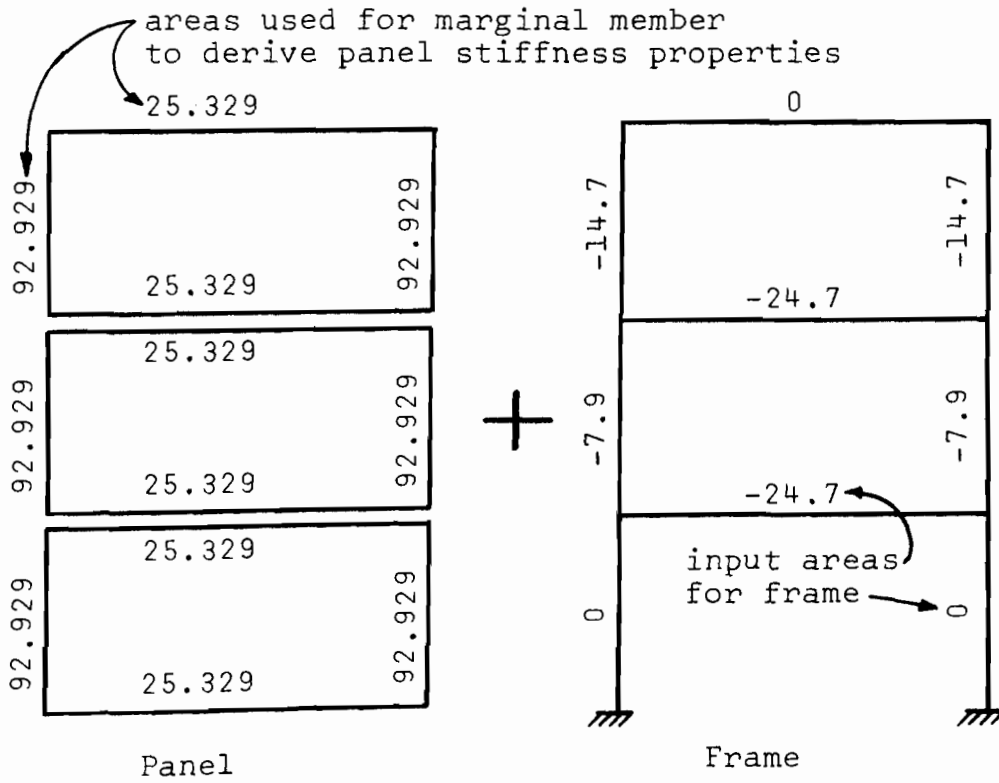

Fig. 4.1 - Three story frame



(areas in in<sup>2</sup>)

Fig. 4.2 - Areas used for three story frame example



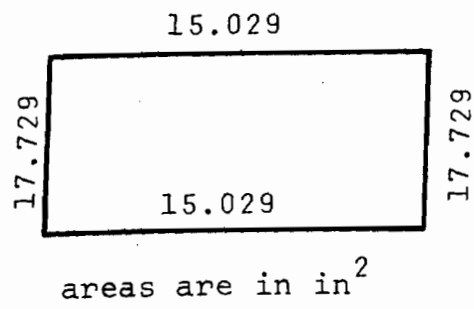

Fig. 4.3 - Areas input for marginal members to derive panel stiffness properties

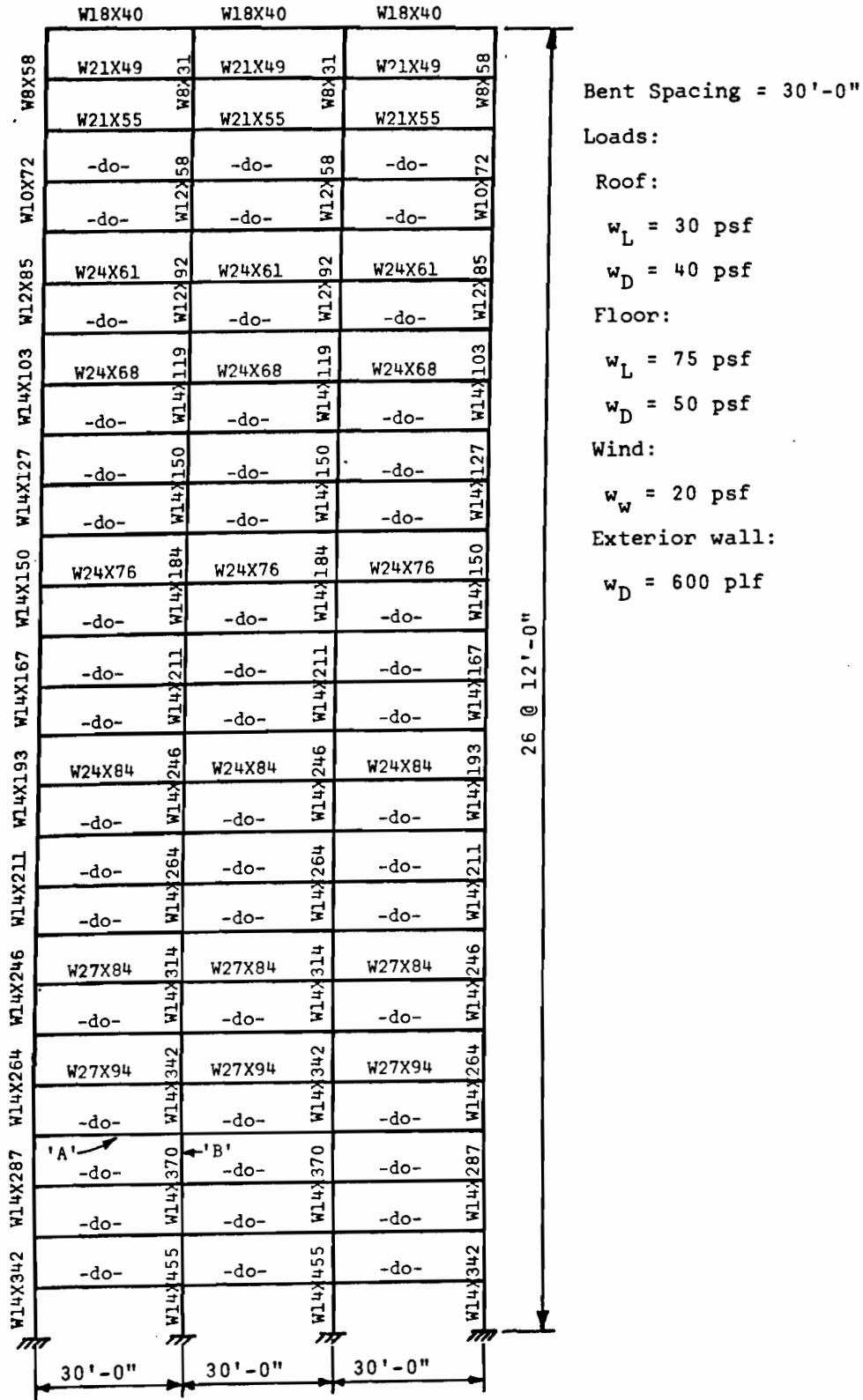

Fig. 4.4 - Twenty-six story frame

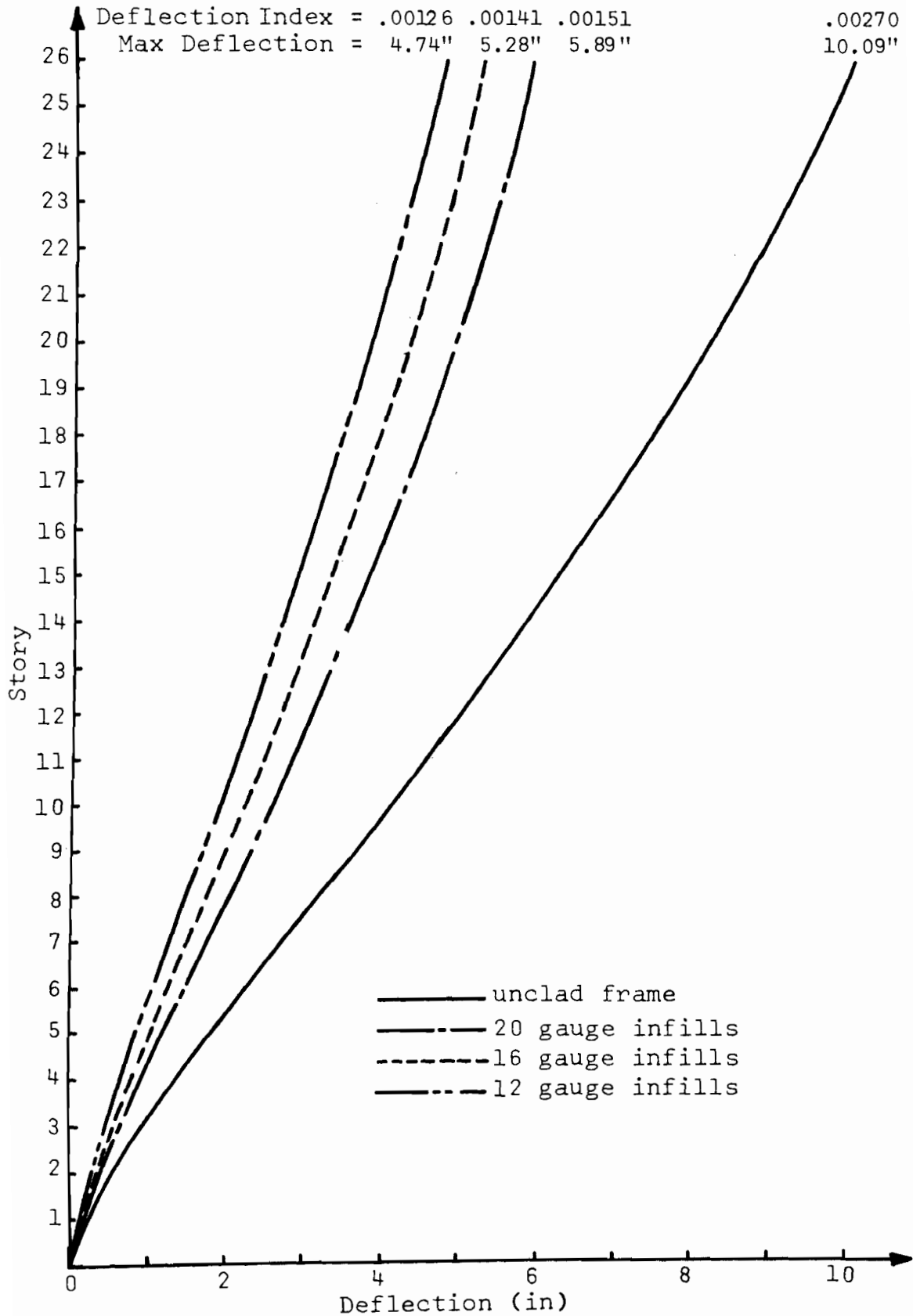
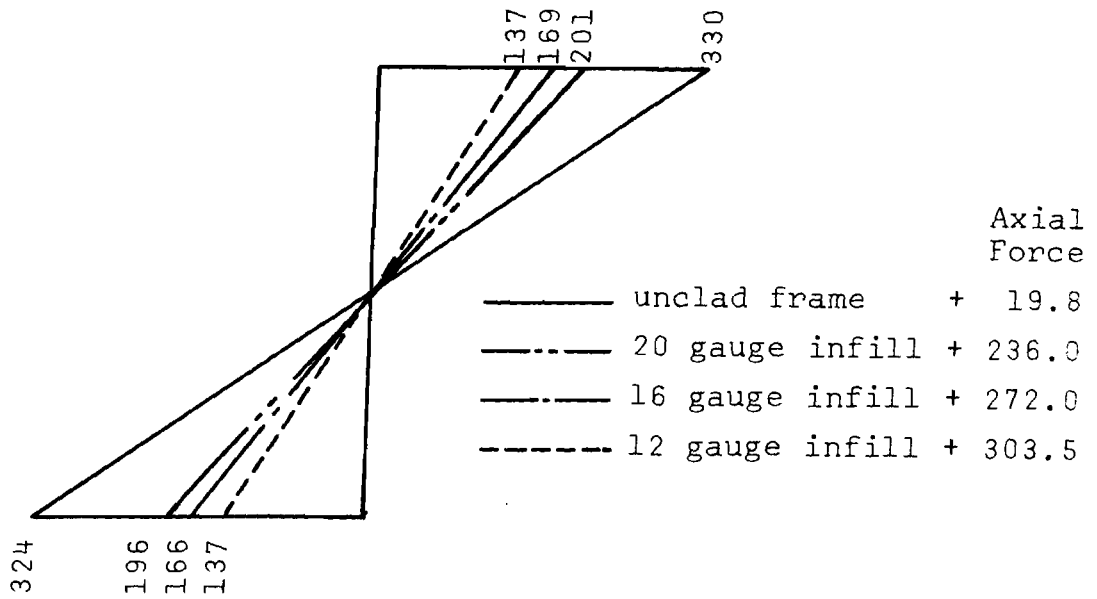
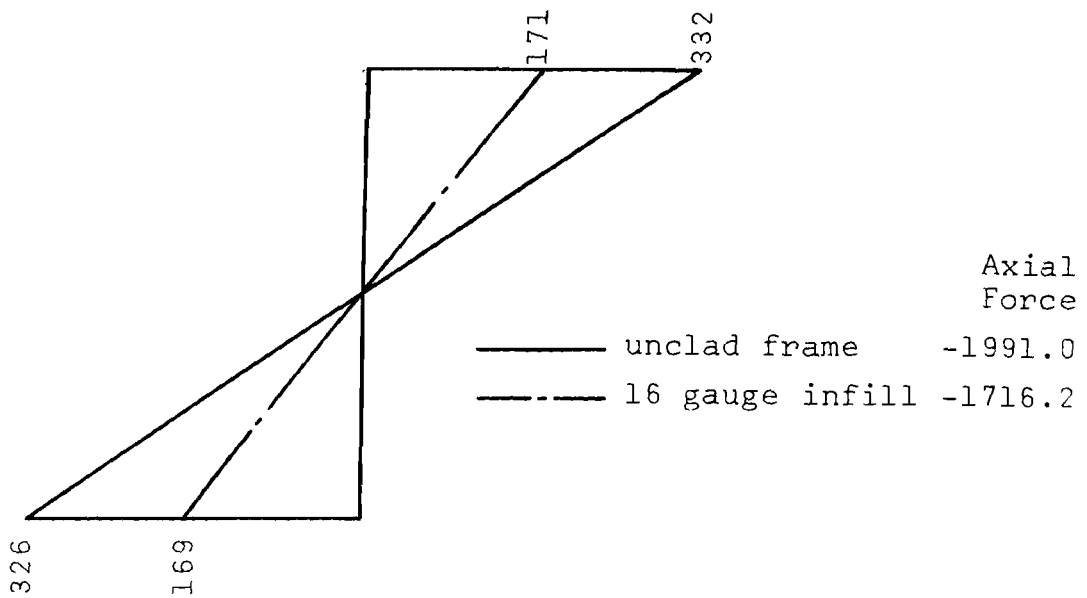

Fig. 4.5 - Deflected shapes for 26 story frames



(a) Lateral load only



(b) Lateral + gravity load

Note: all forces in kips, all moments in foot-kips  
 moments plotted on tension side of member

Fig. 4.6 - Forces and moments in windward interior column  
 between third and fourth floor

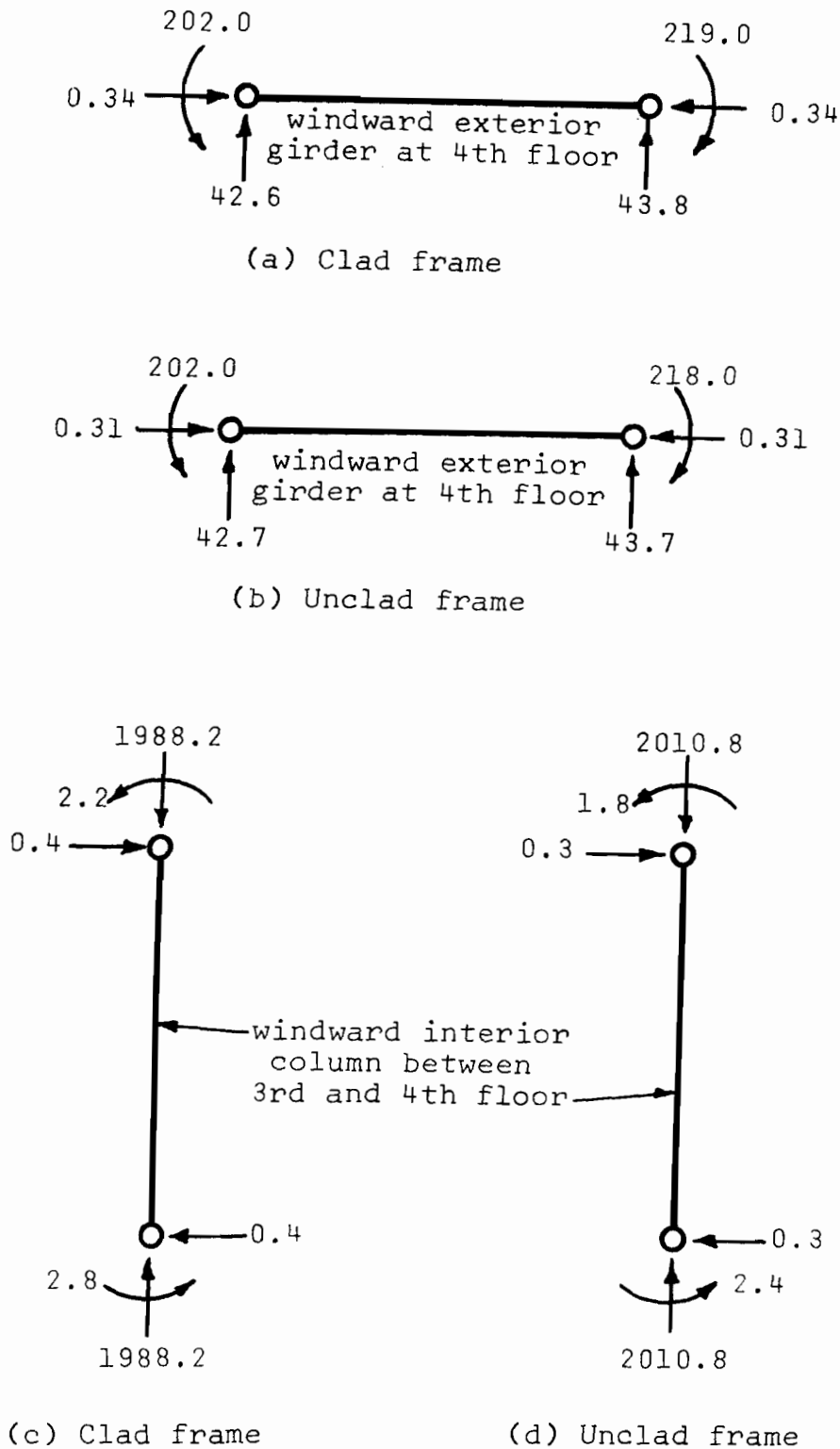

Fig. 4.7 - Comparison of member forces for gravity only load case--clad and unclad frames

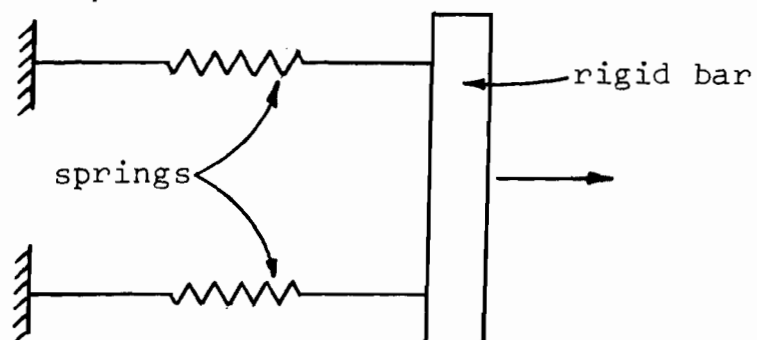
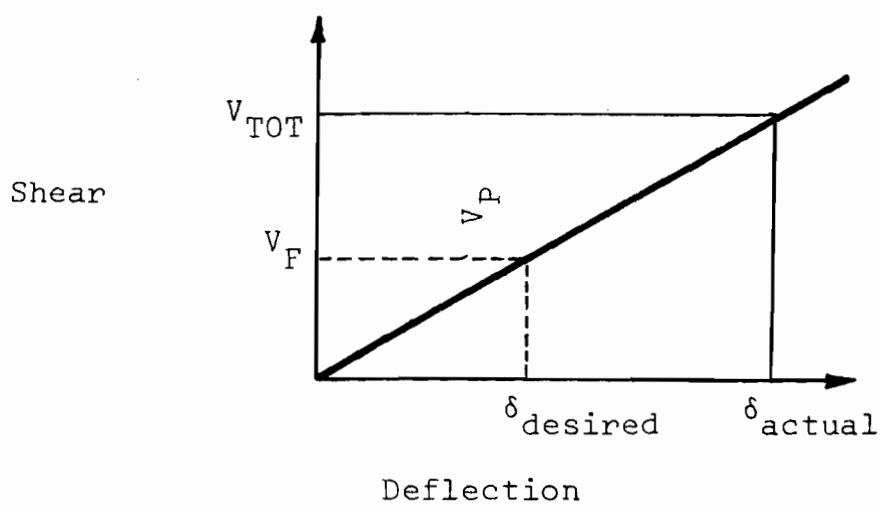

Fig. 4.8 - Two spring model of infilled story high segment



$V_F$  = shear resisted by frame

$V_P$  = shear resisted by panel

Fig. 4.9 - Load-deflection curve for story high frame segment

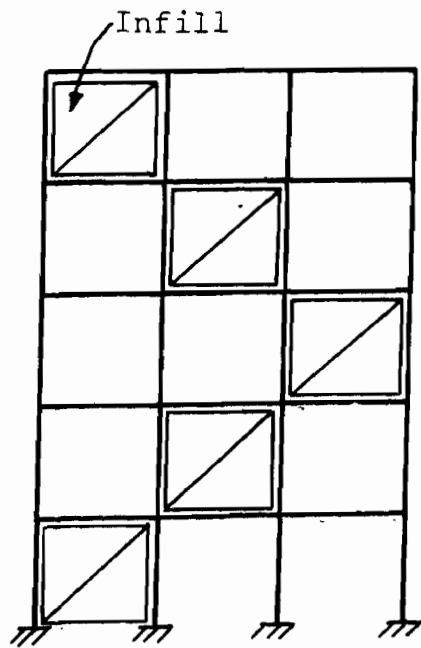

(a) Zig-zag pattern

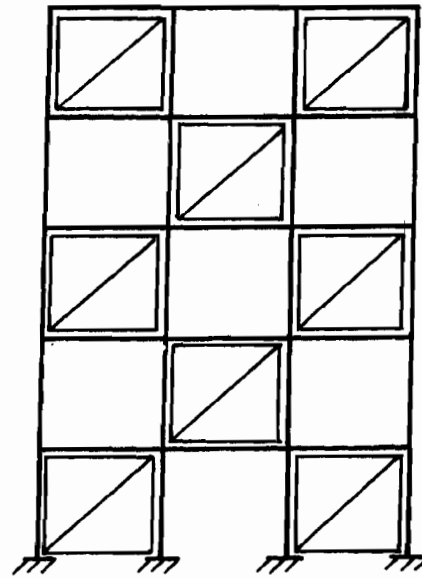

(b) Criss-cross pattern

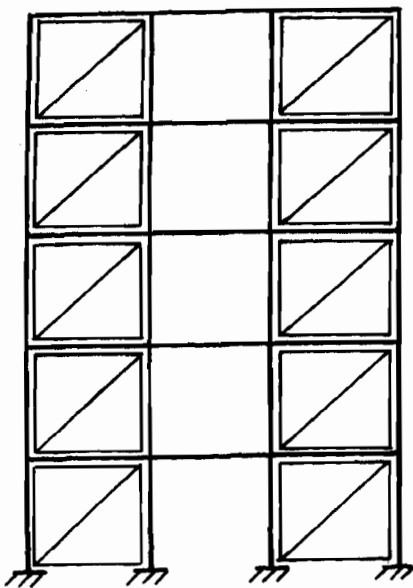

(c) Apartment house pattern

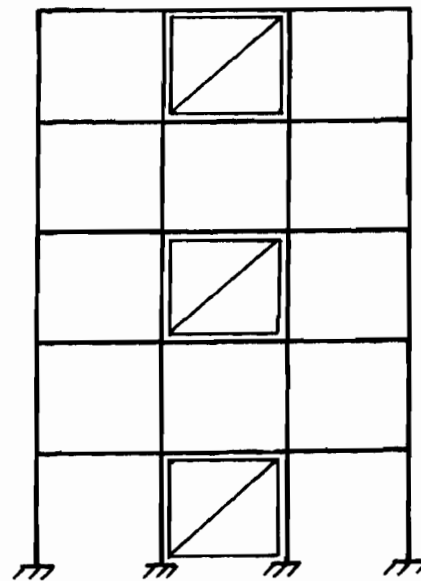

(d) Alternate floors pattern

Fig. 4.10 - Possible infilled frame configurations

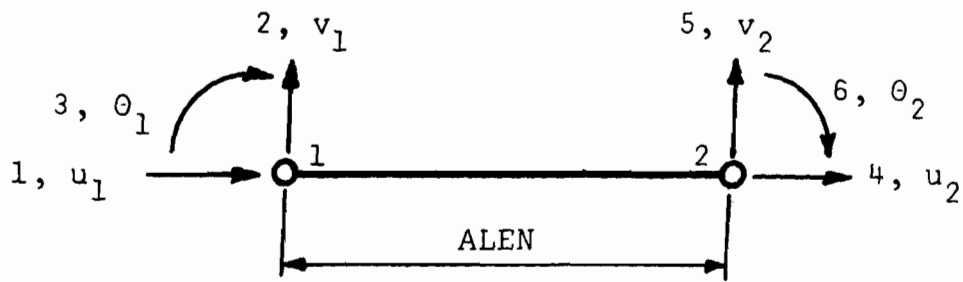

Fig. A1 - Degrees of freedom for beam element (type 1)

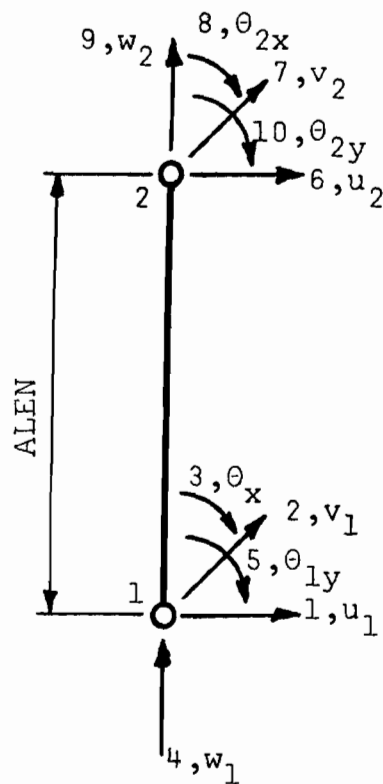

Fig. A2 - Degrees of freedom for column element (type 2)



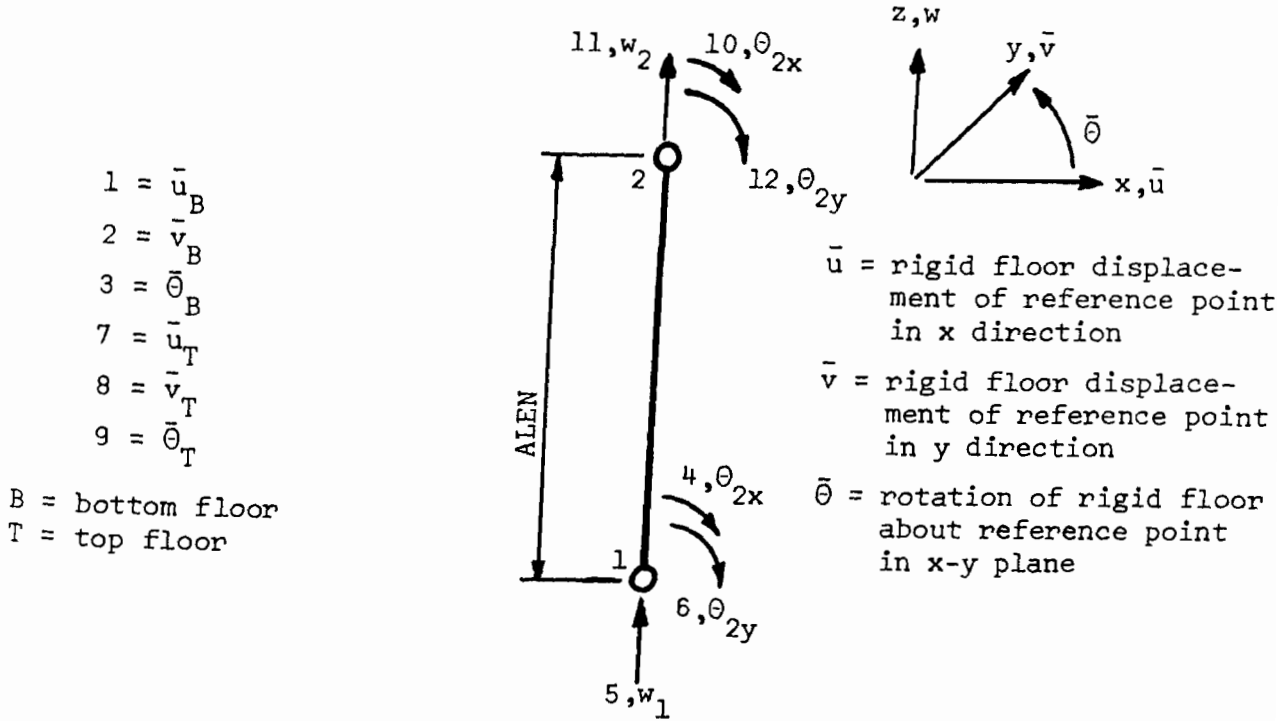

Fig. A3 - Degrees of freedom for column element in rigid floor structure (type 4)

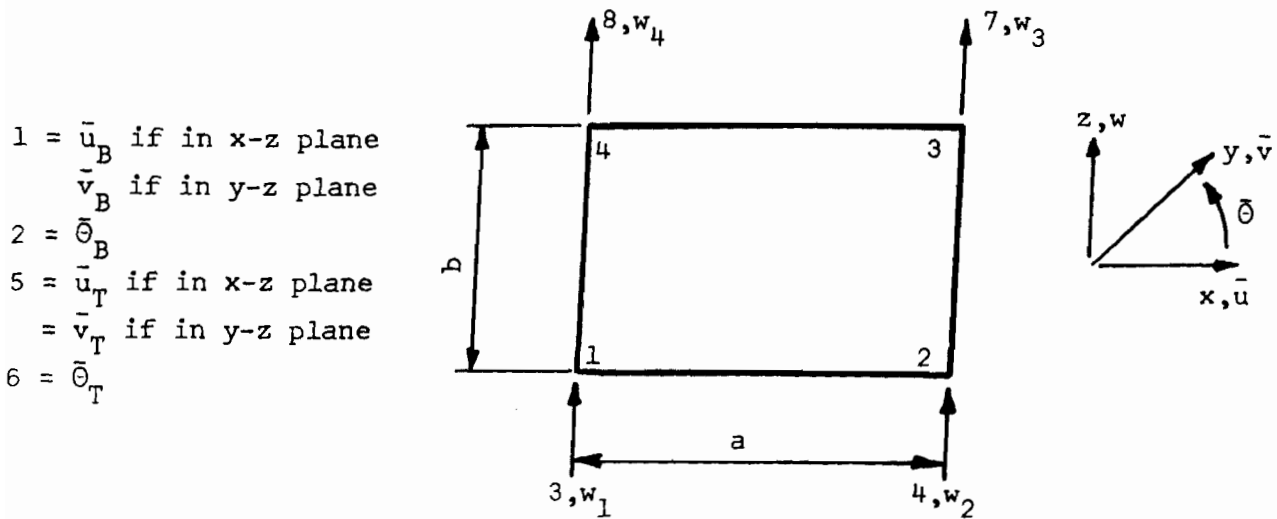
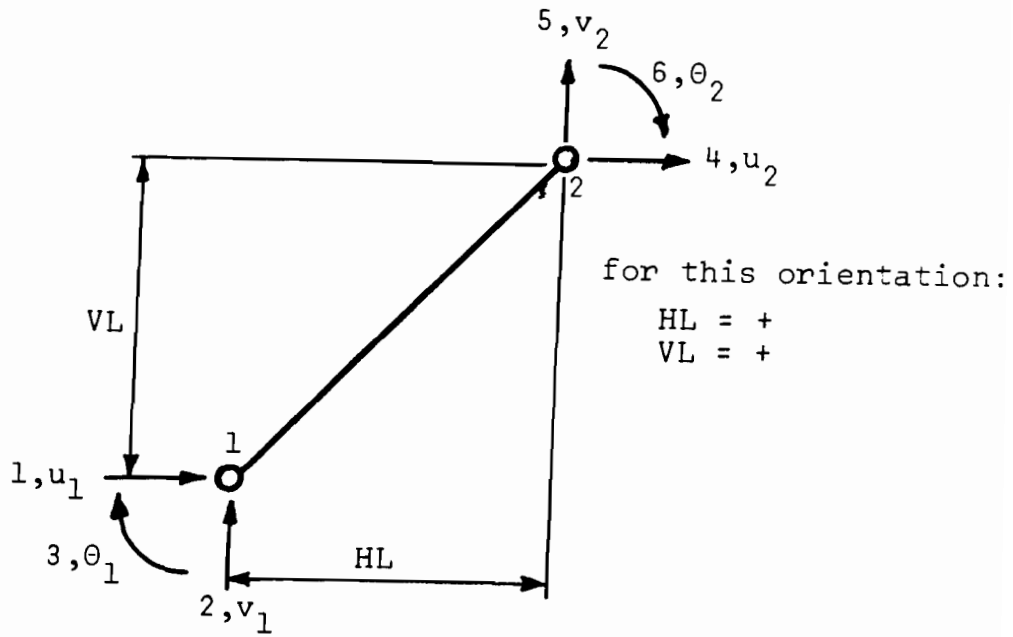

Fig. A4 - Degrees of freedom for plate element in rigid floor structure (type 5)



for this  
 orientation:

$HL = -$   
 $VL = +$

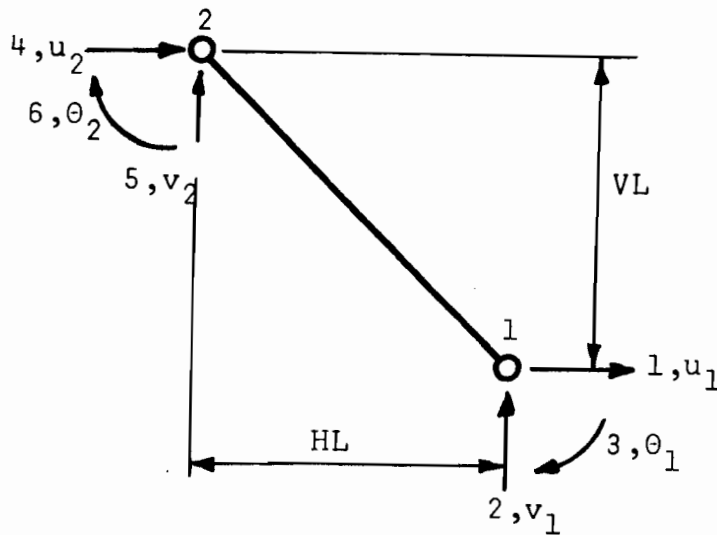
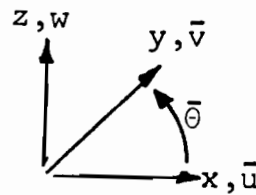
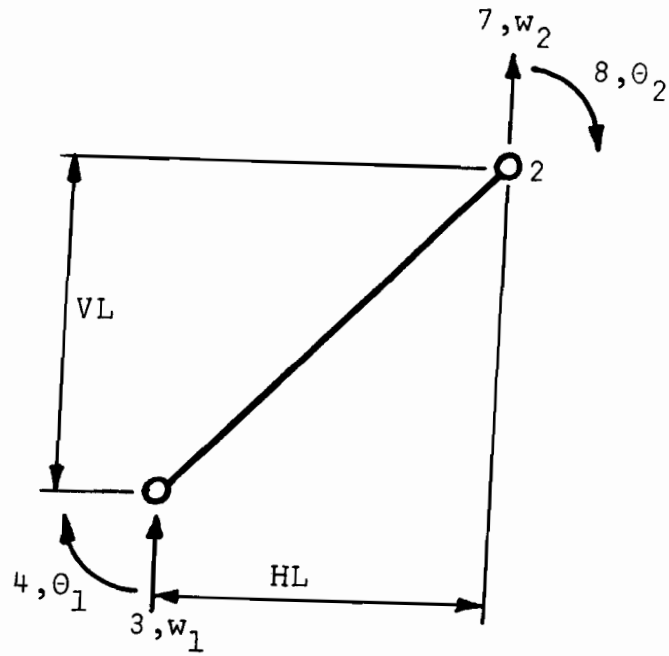

Fig. A5 - Degrees of freedom for diagonal element (type 6)

$1 = \bar{u}_B$  if in x-z plane  
 $= \bar{v}_B$  if in y-z plane  
 $2 = \bar{\theta}_B$   
 $5 = \bar{u}_T$  if in x-z plane  
 $= \bar{v}_T$  if in y-z plane  
 $6 = \bar{\theta}_T$

for this orientation

$HL = +$   
 $VL = +$



Degrees of freedom  
 1, 2, 5 and 6 same  
 as above

for this orientation

$HL = -$   
 $VL = +$

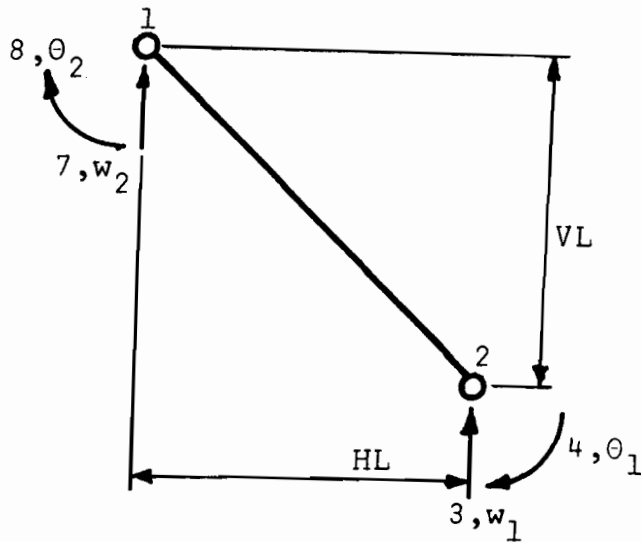
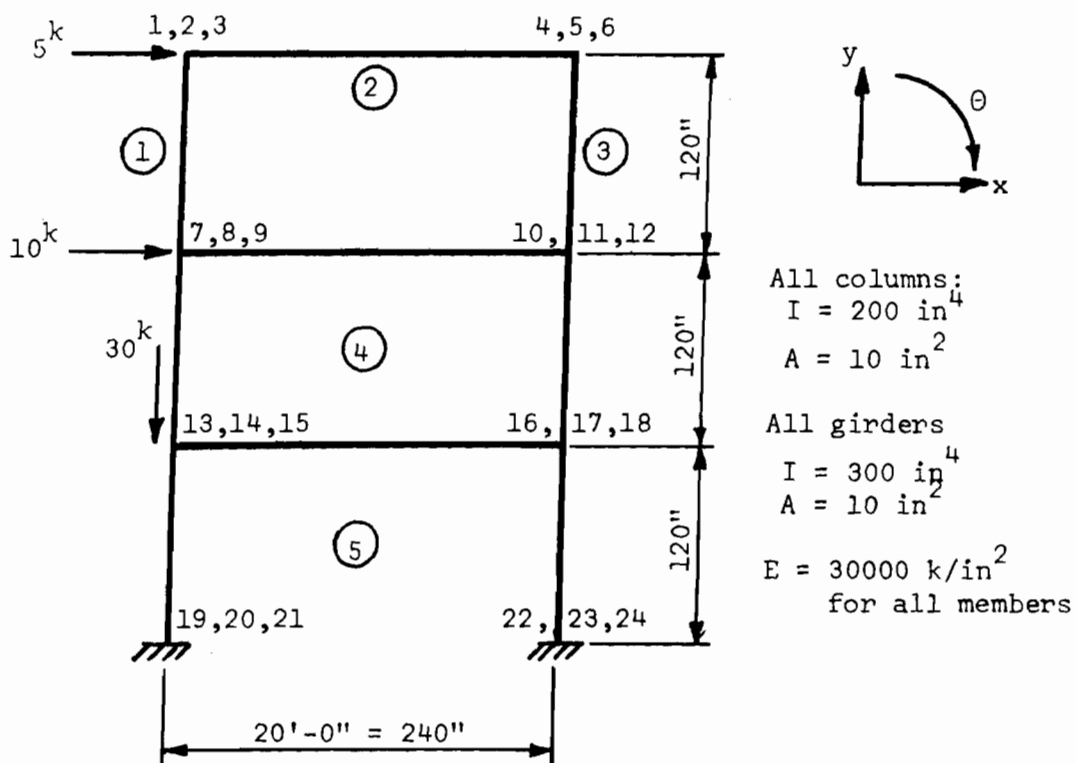
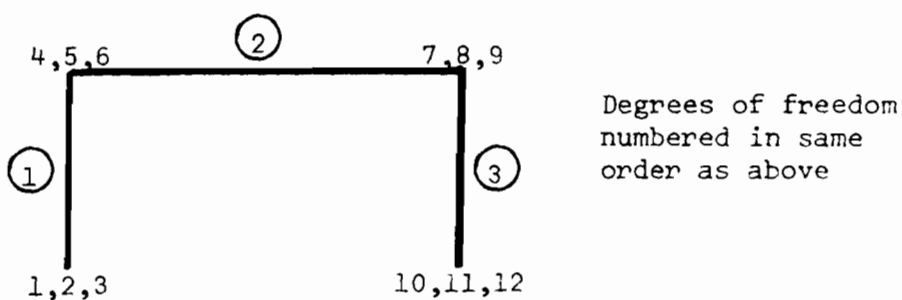

Fig. A6 - Degrees of freedom for diagonal element in rigid floor structure

Degrees of freedom are numbered in the order  $x, y, \theta$



(a) Frame



(b) Subassembly

Fig. A7 - Three story frame for example problem

BEGINNING OF A NEW PROBLEM

EXAMPLE PROBLEM  
THREE STORY FRAME

DOF 1	0.1159770-01	DOF 2	-0.3669180-02	DOF 3	0.1004370-02	DOF 4	0.1157050-01	DOF 5	-0.8330820-02
DOF 6	0.1025840-02	DOF 7	0.8893830-00	DOF 8	-0.4415940-02	DOF 9	0.2501160-02	DOF 10	0.8854470-00
DOF 11	-0.7584760-02	DOF 12	0.2497160-02	DOF 13	0.3688630-00	DOF 14	-0.7024540-02	DOF 15	0.3156490-02
DOF 16	0.3688100-00	DOF 17	-0.4975460-02	DOF 18	0.3138750-02	DOF 19	0.7478060-19	DOF 20	-0.1756140-18
DOF 21	0.6065080-17	DOF 22	0.7521940-19	DOF 23	-0.1243860-18	DOF 24	0.6082190-17	DOF	

REACTION ASSOCIATED WITH DOF NO. 19 IS -0.74780660 01  
 REACTION ASSOCIATED WITH DOF NO. 20 IS 0.175613610 02  
 REACTION ASSOCIATED WITH DOF NO. 21 IS -0.606507690 03  
 REACTION ASSOCIATED WITH DOF NO. 22 IS -0.752194340 01  
 REACTION ASSOCIATED WITH DOF NO. 23 IS 0.124386390 02  
 REACTION ASSOCIATED WITH DOF NO. 24 IS -0.608219030 03

ELEMENT 1 FORCES ARE  
 1 -0.2473050 01 2 -0.1866970 01 3 -0.7354390 02 4 0.2473050 01 5 0.1866970 01 6 -0.2232230 03

ELEMENT 2 FORCES ARE  
 1 0.2526950 01 2 -0.1866970 01 3 0.2232230 03 4 -0.2526950 01 5 0.1866970 01 6 0.2248330 03

ELEMENT 3 FORCES ARE  
 1 -0.2526950 01 2 0.1866970 01 3 -0.7840060 02 4 0.2526950 01 5 -0.1866970 01 6 -0.2248330 03

ELEMENT 4 MEMBER 1 FORCES ARE  
 1 -0.7544250 01 2 -0.6521500 01 3 -0.4198880 03 4 0.7544250 01 5 0.6521500 01 6 -0.4854210 03

ELEMENT 4 MEMBER 2 FORCES ARE  
 1 0.4928810 01 2 -0.4654610 01 3 0.5589650 03 4 -0.4928810 01 5 0.4654610 01 6 0.5581470 03

ELEMENT 4 MEMBER 3 FORCES ARE  
 1 -0.7455750 01 2 0.6521500 01 3 -0.4149510 03 4 0.7455750 01 5 -0.6521500 01 6 -0.4797470 03

ELEMENT 5 MEMBER 1 FORCES ARE  
 1 -0.7478060 01 2 0.1756140 02 3 -0.6065080 03 4 0.7478060 01 5 -0.1756140 02 6 -0.2908590 03

ELEMENT 5 MEMBER 2 FORCES ARE  
 1 0.6619160-01 2 -0.5917130 01 3 0.7107480 03 4 -0.6619160-01 5 0.5917130 01 6 0.7093650 03

ELEMENT 5 MEMBER 3 FORCES ARE  
 1 -0.7521940 01 2 0.1243860 02 3 -0.6082190 03 4 0.7521940 01 5 -0.1243860 02 6 -0.2944140 03

CORE USAGE OBJECT CODE= 56664 BYTES, ARRAY AREA= 214208 BYTES, TOTAL AREA AVAILABLE= 299104 BYTES

Fig. A8 - Sample output for three story frame problem

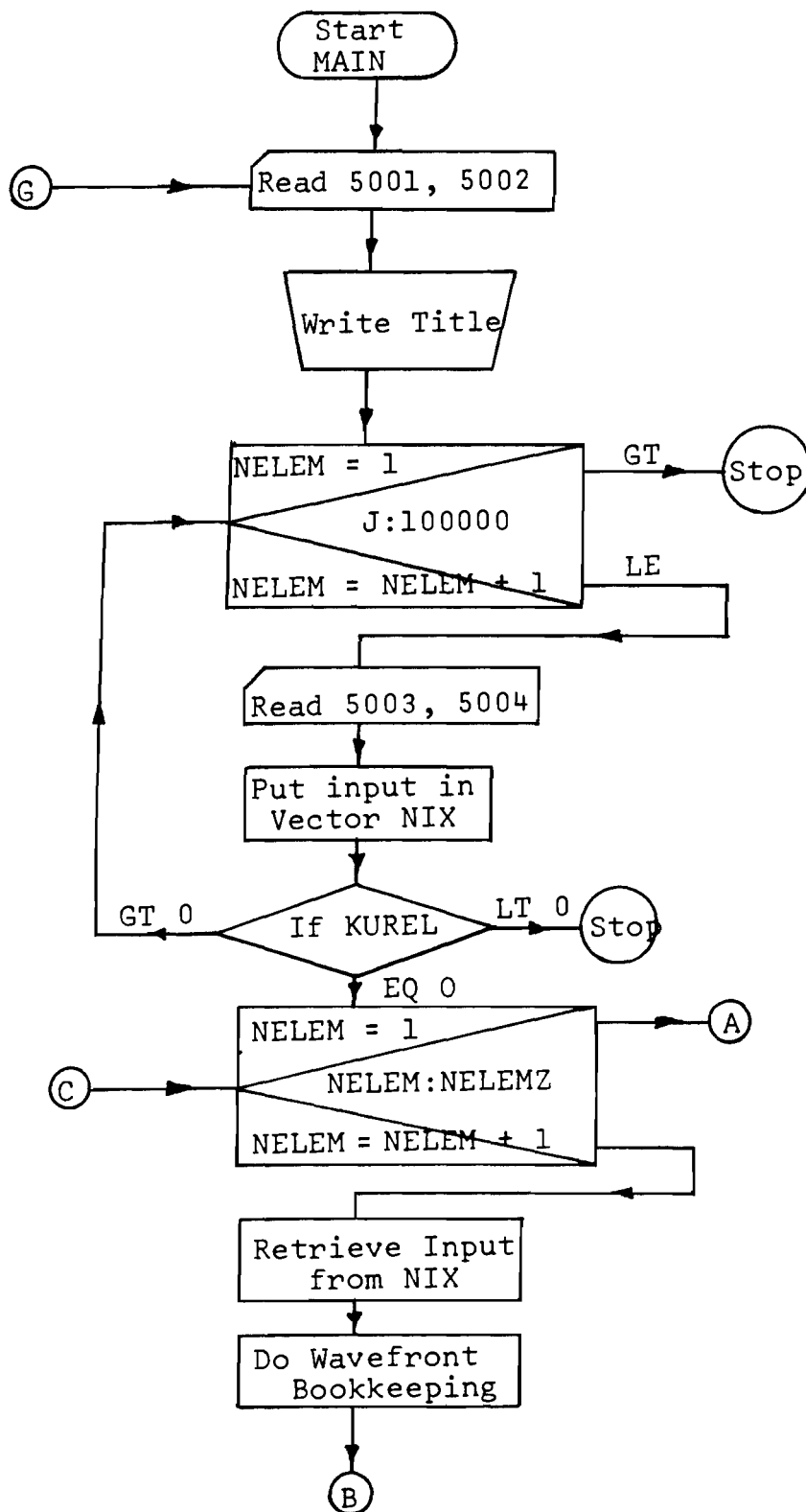

Fig. A9 - Flow chart for main routine

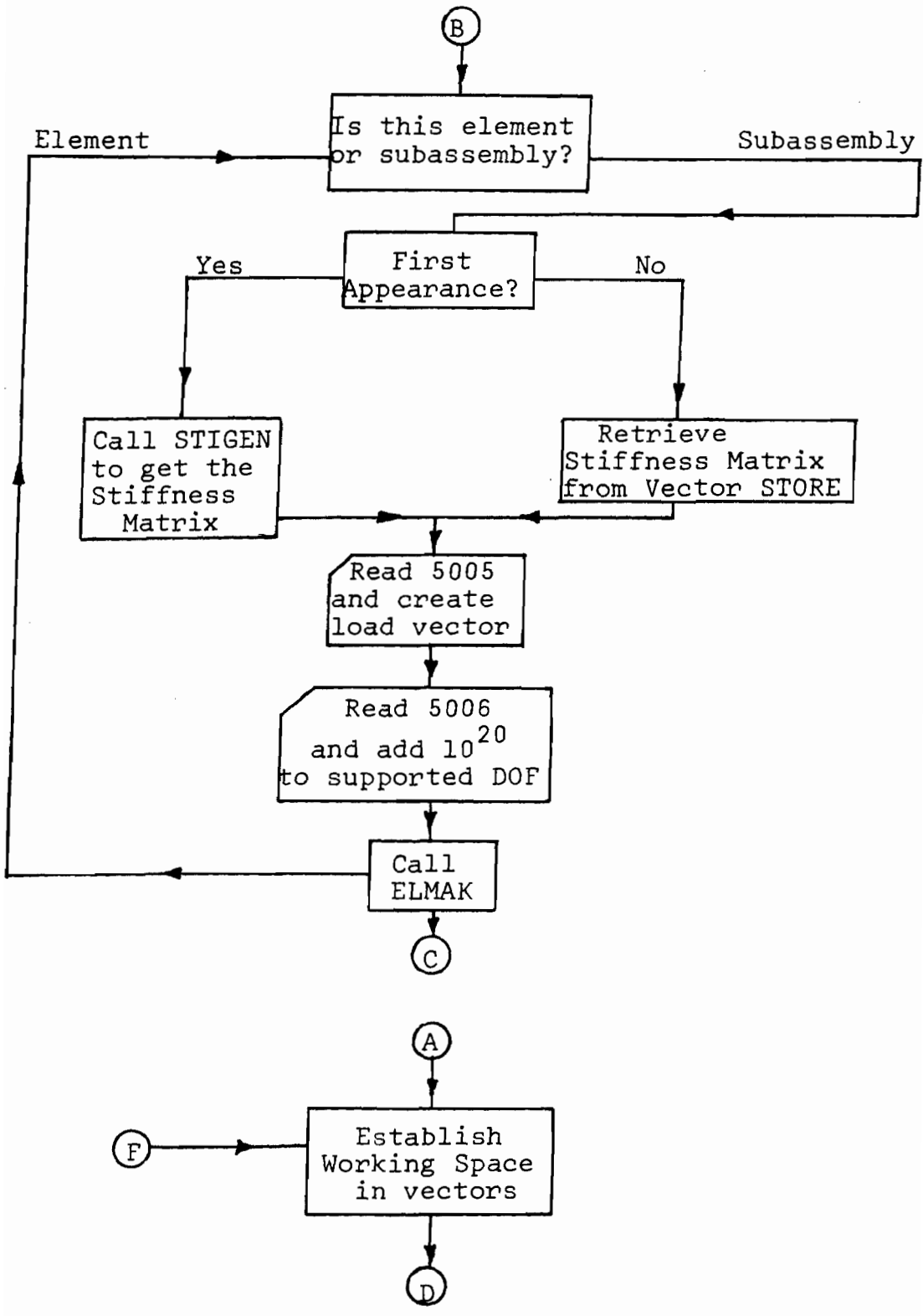

Fig. A9 - Flow chart for main routine (cont.)

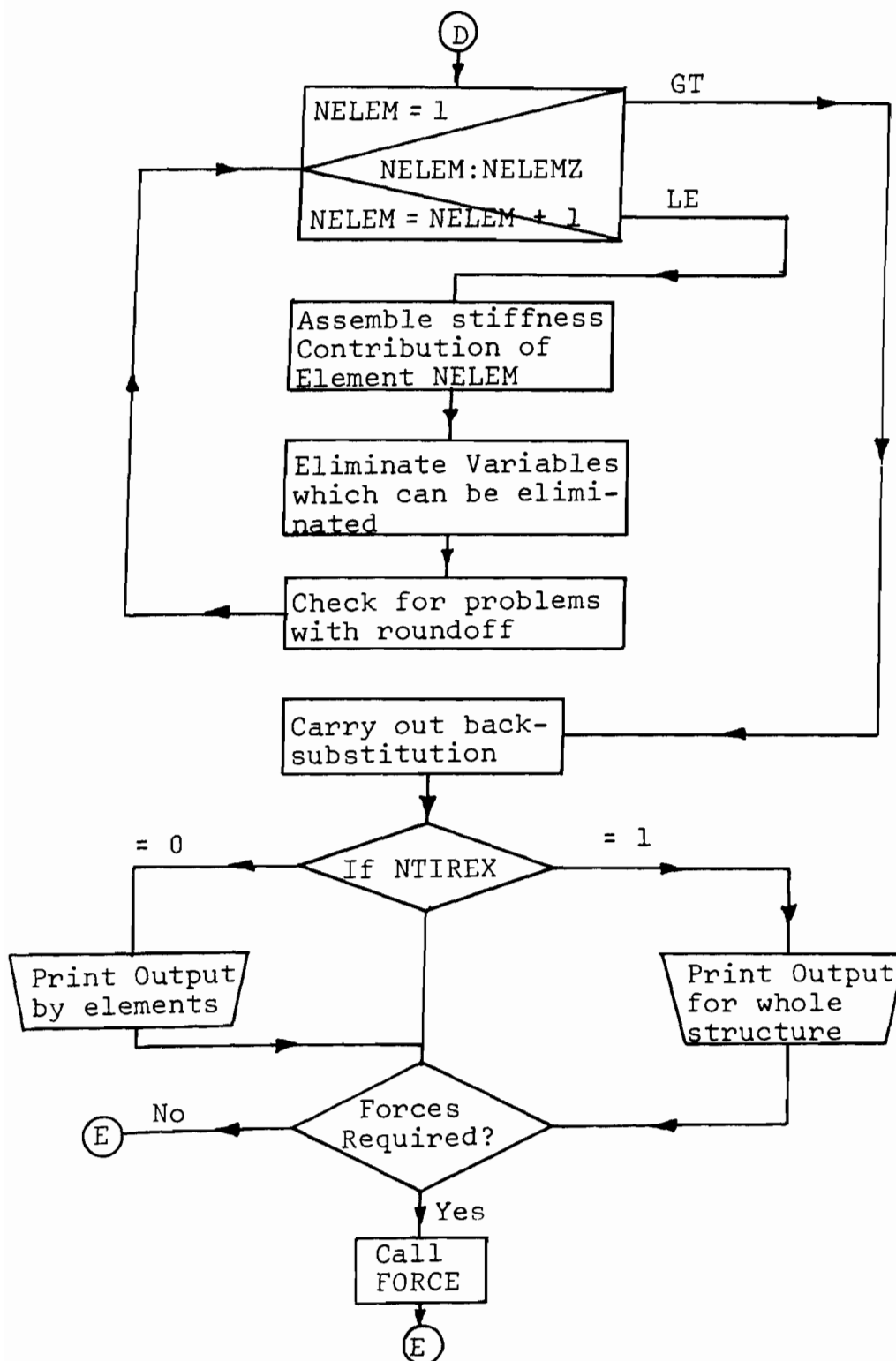

Fig. A9 - Flow chart for main routine (cont.)



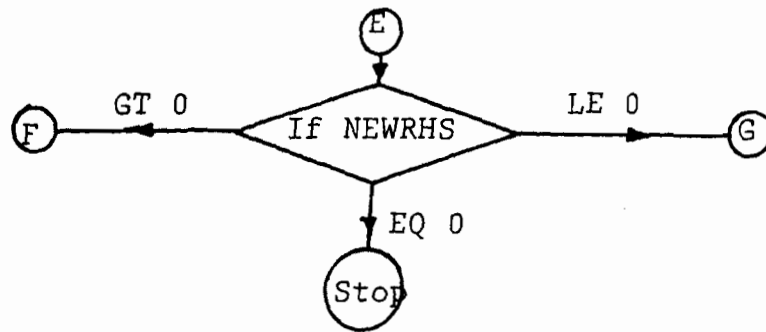

Fig. A9 - Flow chart for main routine (cont.)

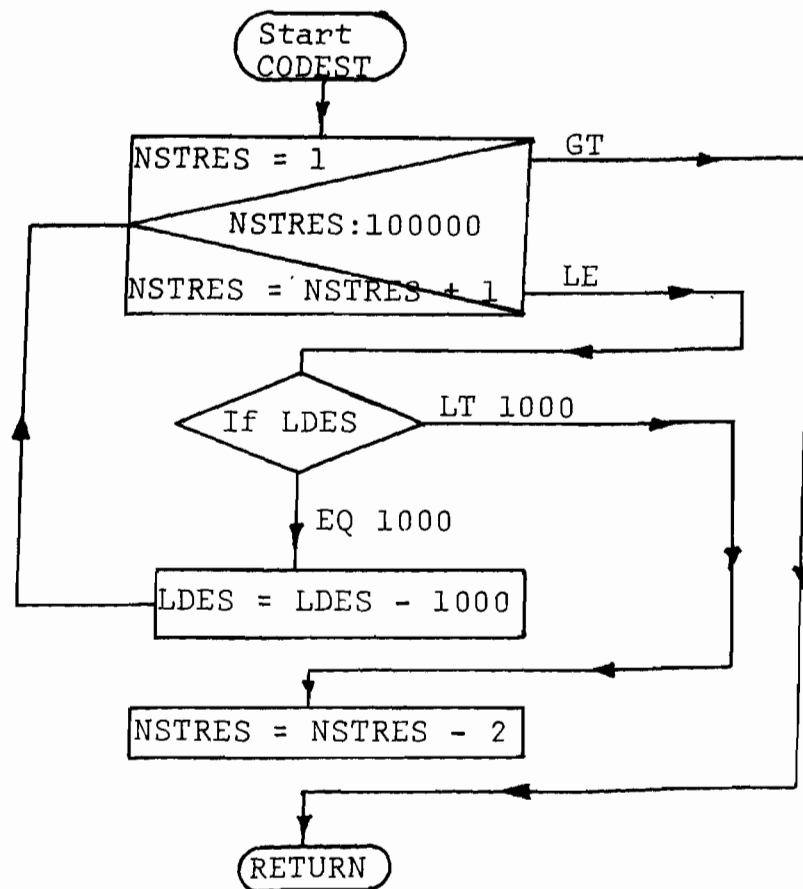

Fig. A10 - Flow chart for subroutine CODEST

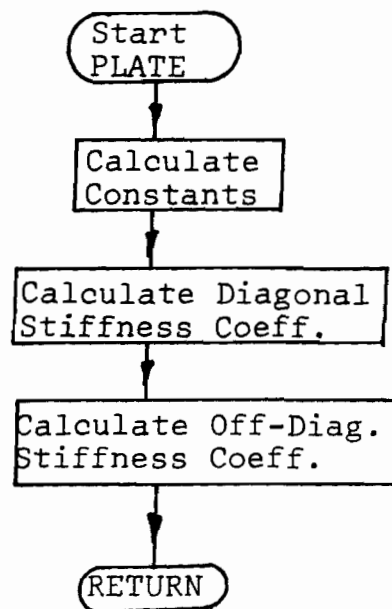

Fig. A11 - Flow chart for subroutine PLATE

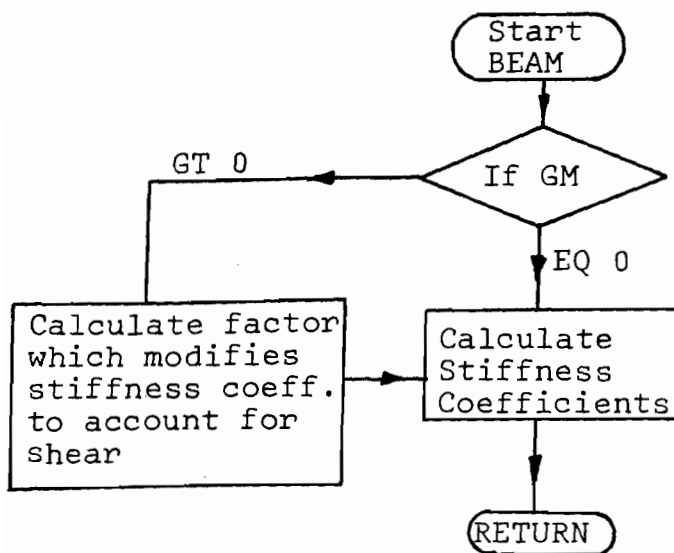

Fig. A12 - Flow chart for subroutine BEAM

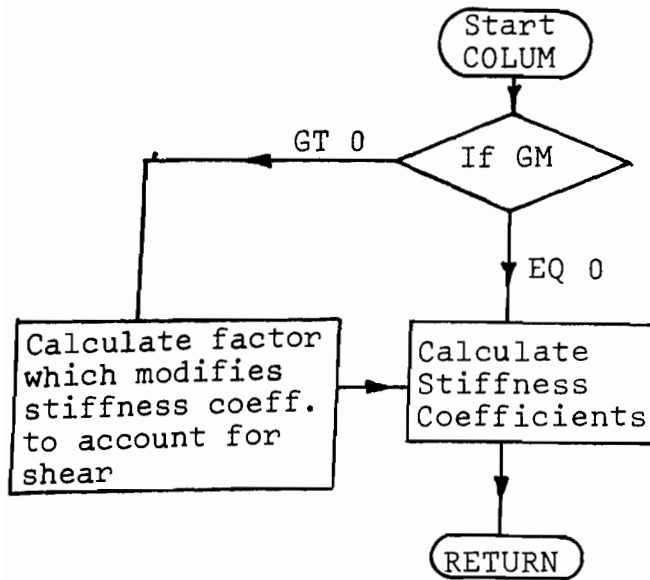

Fig. A13 - Flow chart for subroutine COLUM

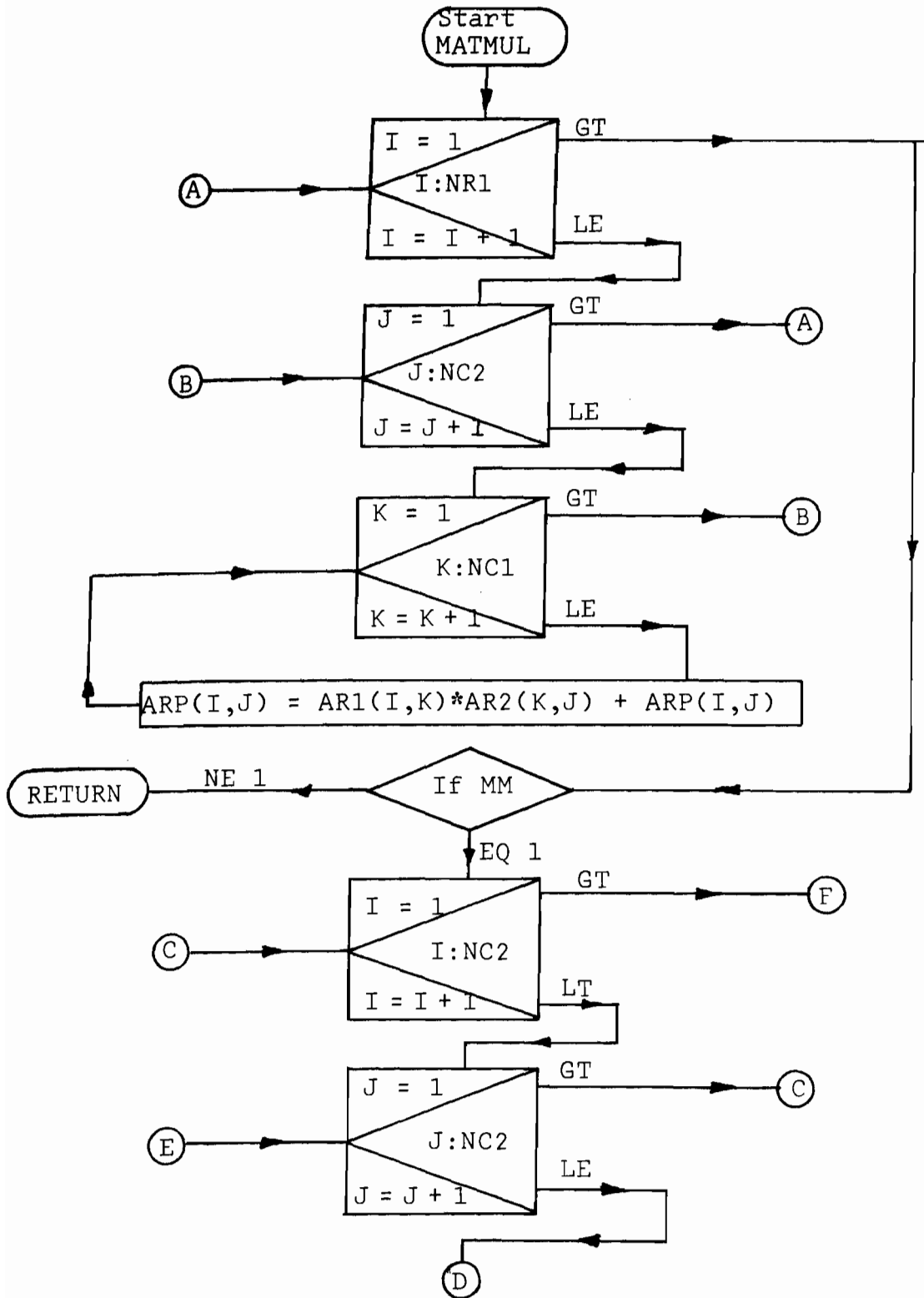

Fig. A14 - Flow chart for subroutine MATMUL

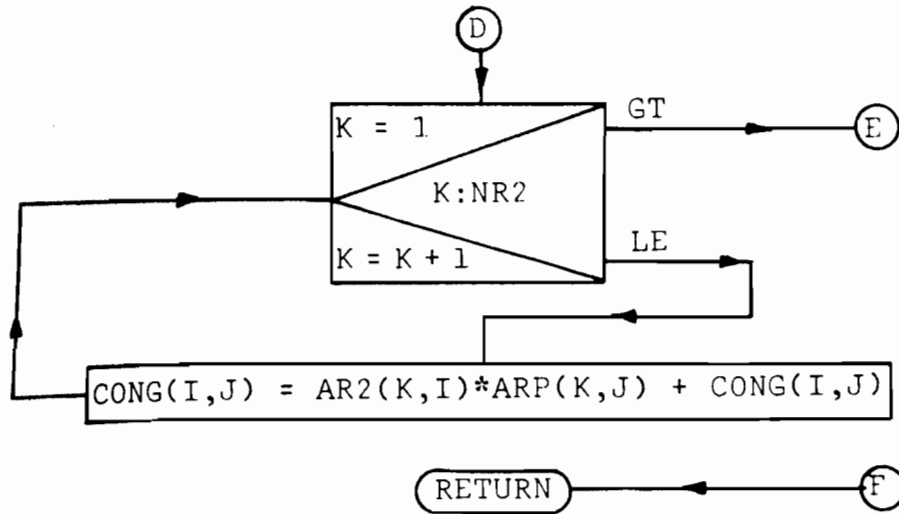

Fig. A14 - Flow chart for subroutine MATMUL (cont.)

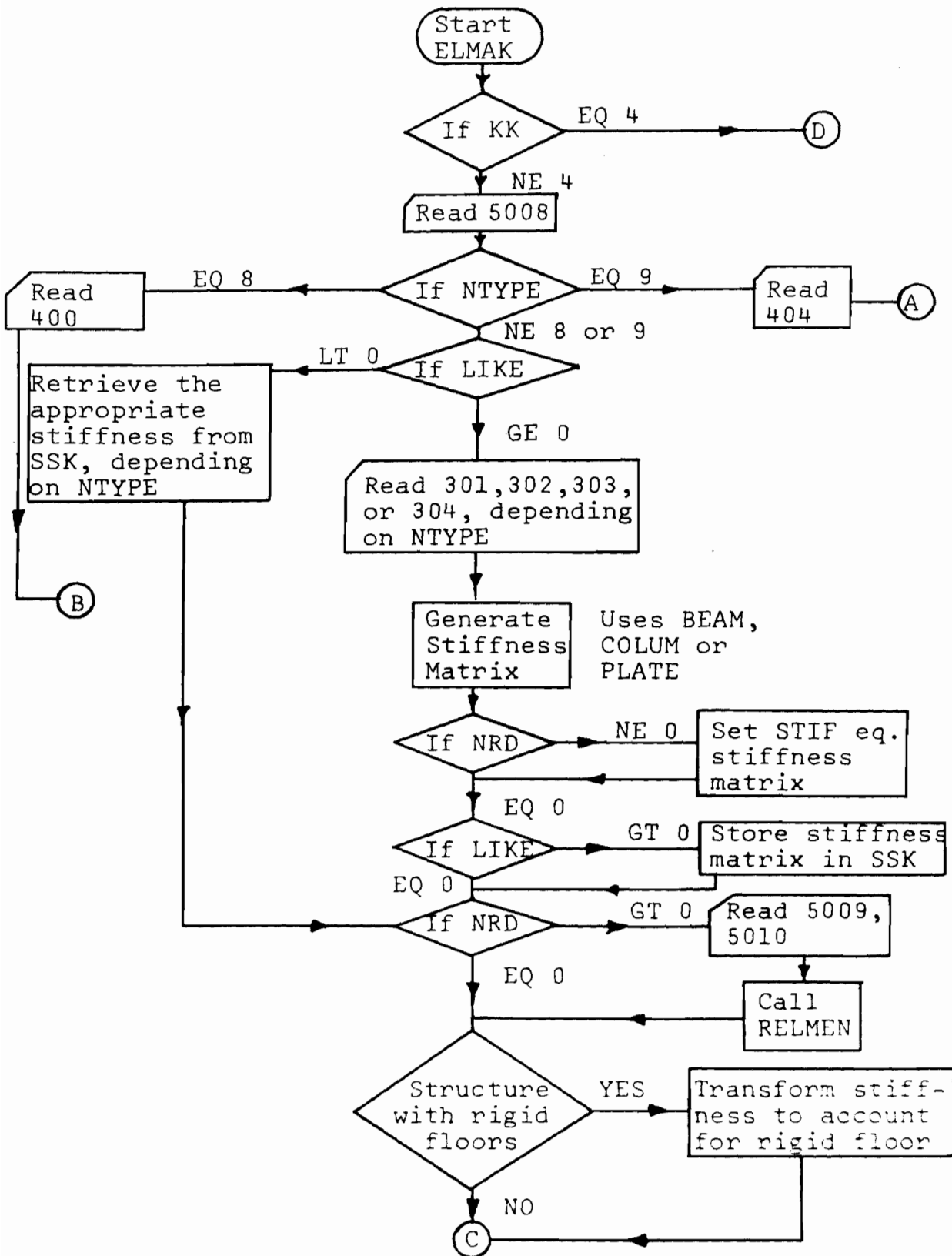

Fig. A15 - Flow chart for subroutine ELMAK

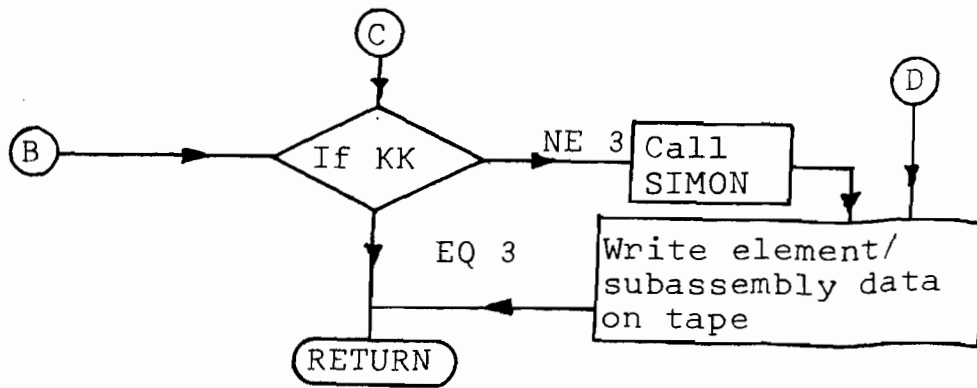

Fig. A15 - Flow chart for subroutine ELMAX (cont.)



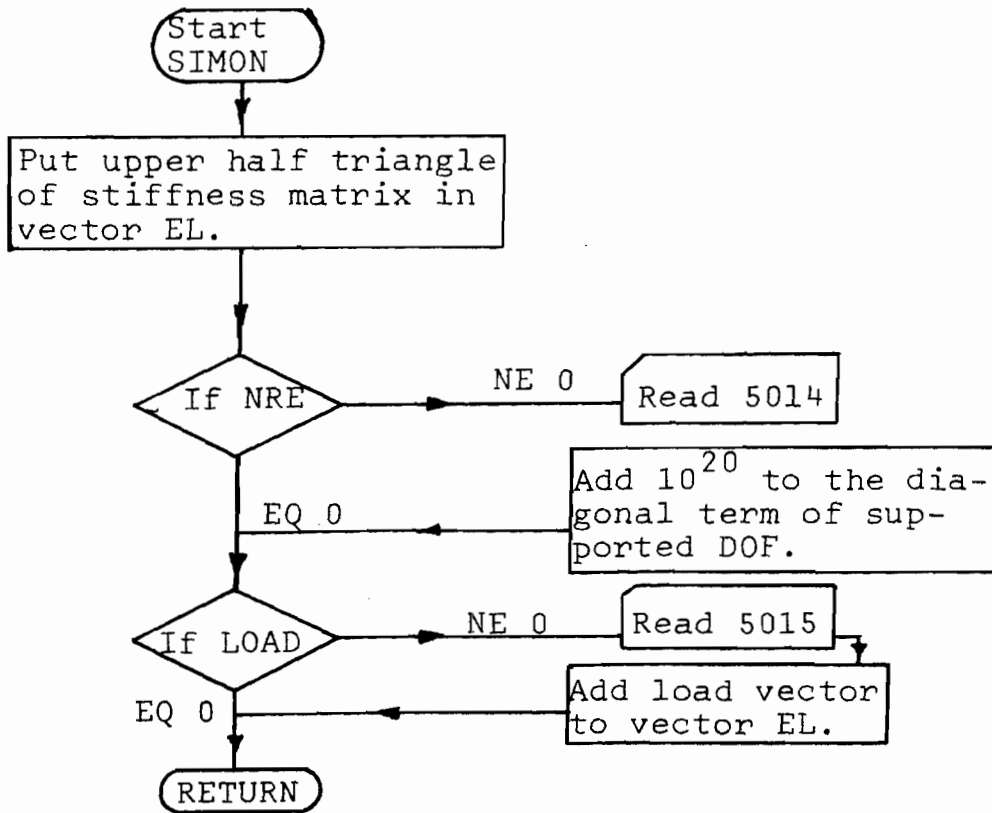

Fig. A16 - Flow chart for subroutine SIMON

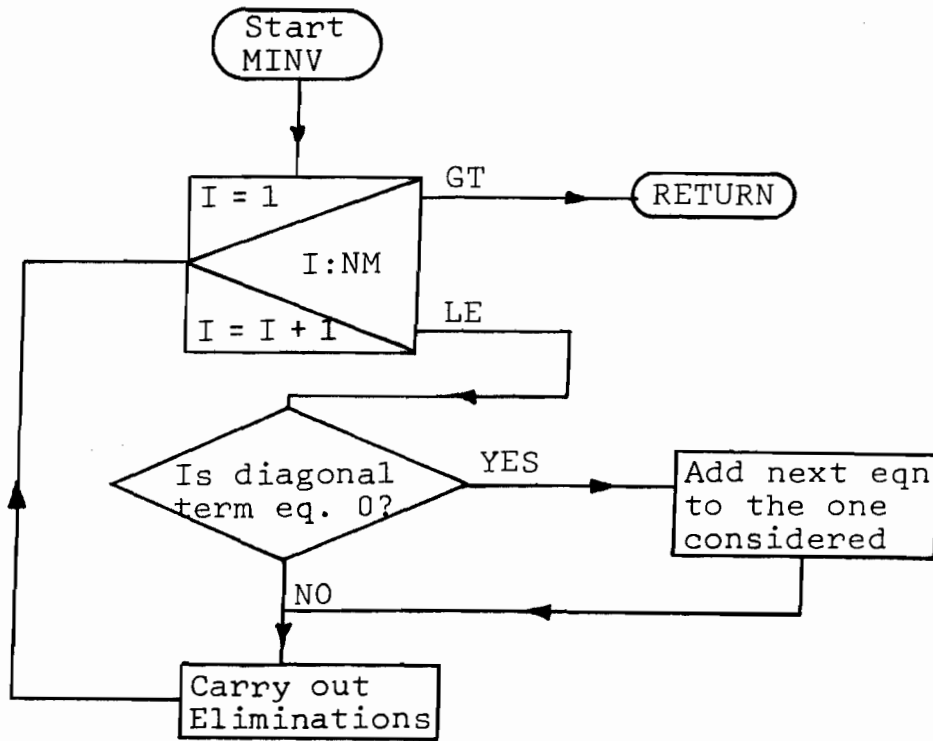

Fig. A17 - Flow chart for subroutine MINV

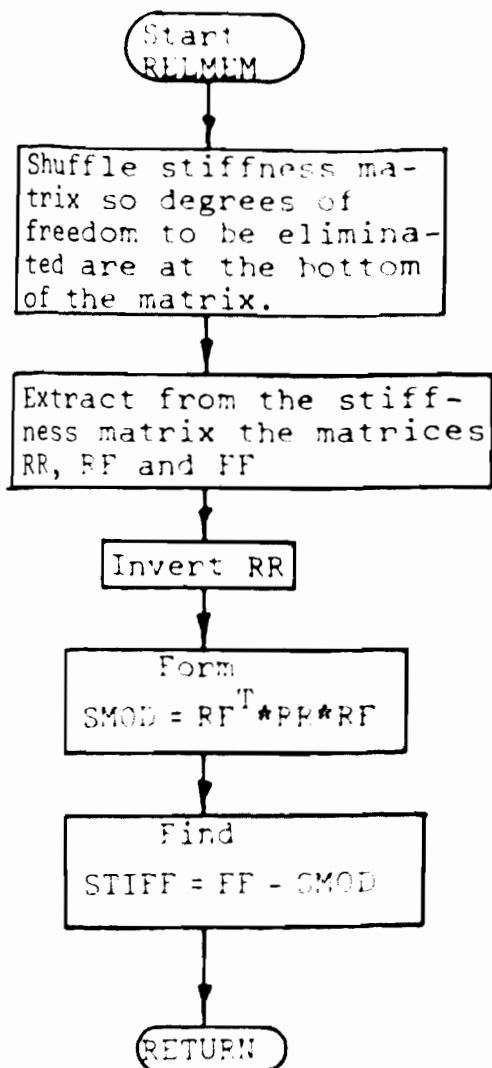

Fig. A18 - Flow chart for subroutine PELMEM

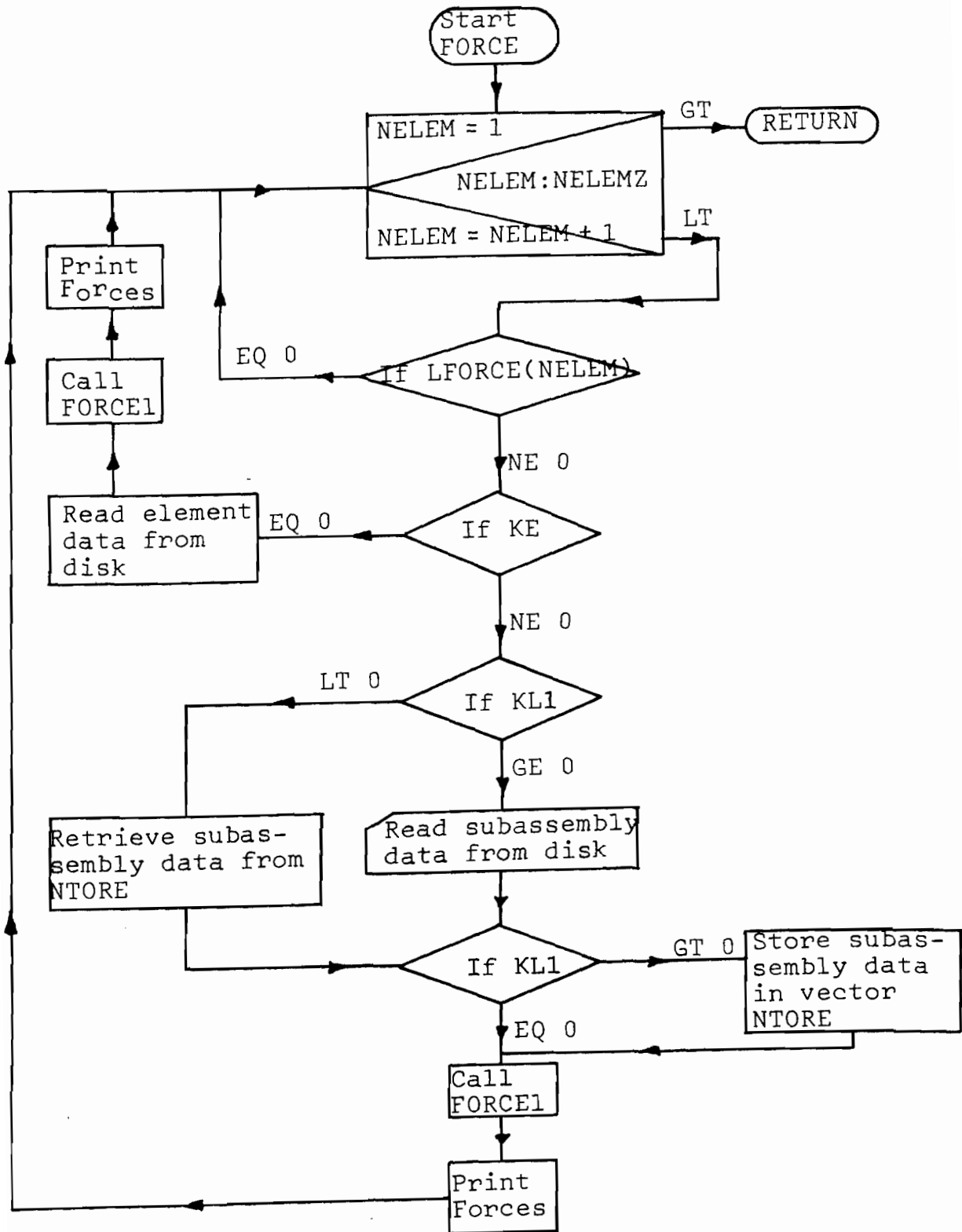

Fig. A19 - Flow chart for subroutine FORCE

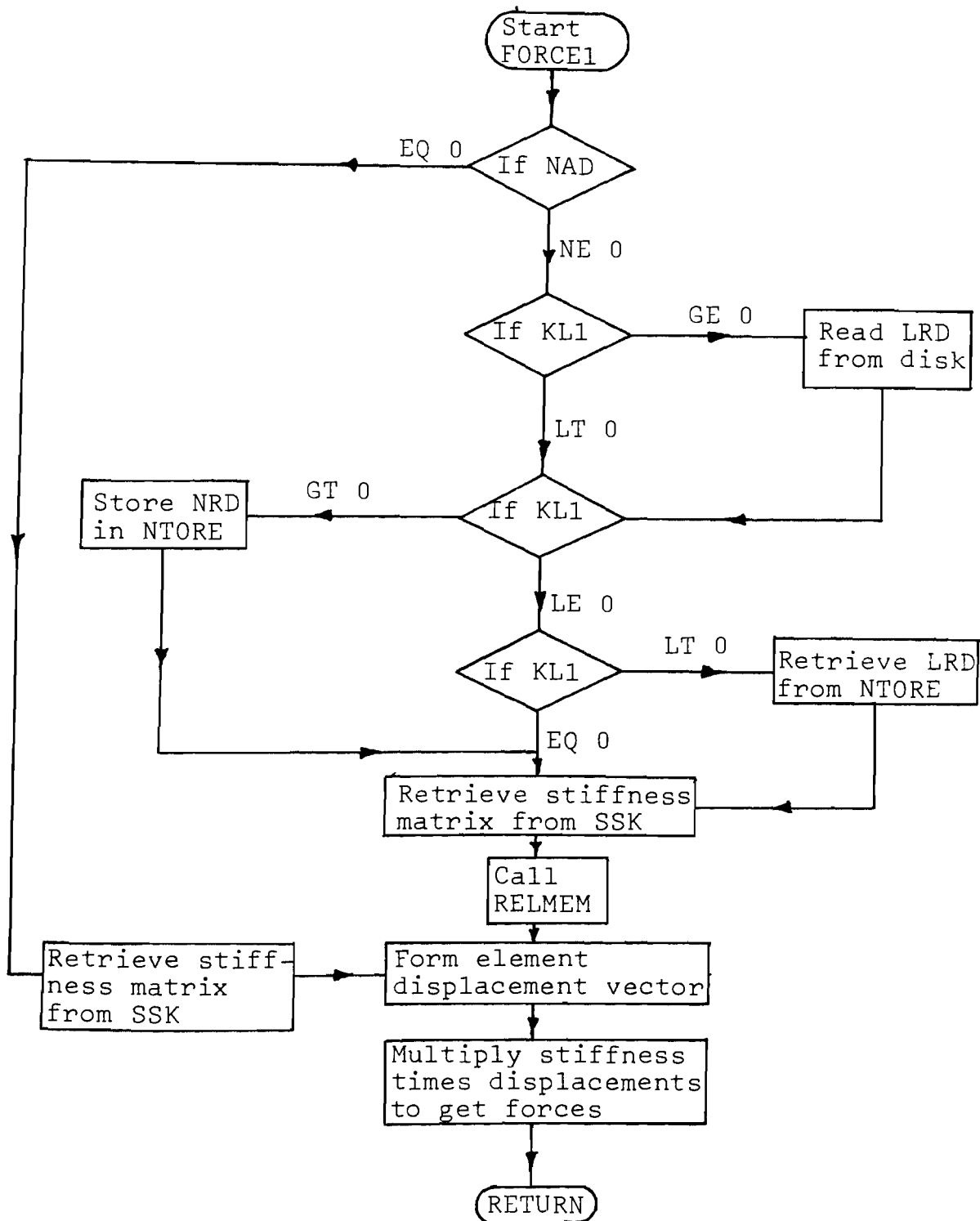

Fig. A20 - Flow chart for subroutine FORCE1

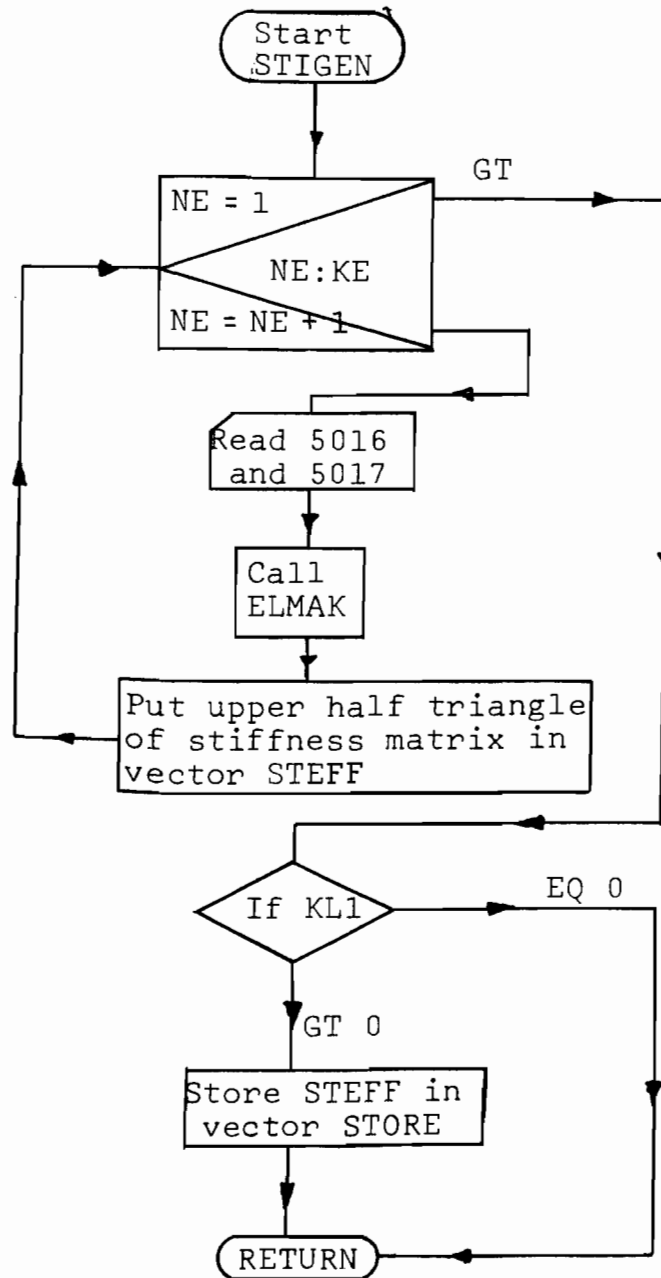

Fig. A21 - Flow chart for subroutine STIGEN

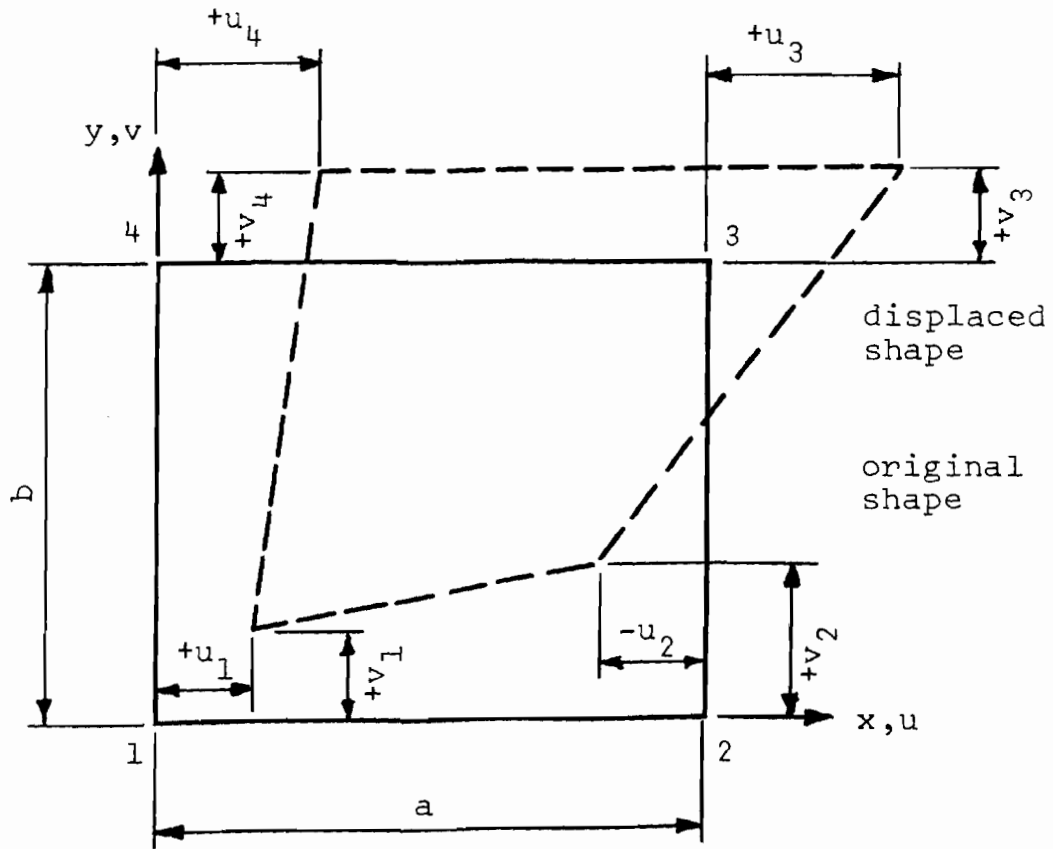

Fig. B1 - Rectangular plane stress element

