

01 Jan 1971

Analysis of light gage steel shear diaphragms

Albert R. Ammar

Arthur H. Nilson

Follow this and additional works at: <https://scholarsmine.mst.edu/ccfss-library>



Part of the [Structural Engineering Commons](#)

Recommended Citation

Ammar, Albert R. and Nilson, Arthur H., "Analysis of light gage steel shear diaphragms" (1971). *Center for Cold-Formed Steel Structures Library*. 85.

<https://scholarsmine.mst.edu/ccfss-library/85>

This Technical Report is brought to you for free and open access by Scholars' Mine. It has been accepted for inclusion in Center for Cold-Formed Steel Structures Library by an authorized administrator of Scholars' Mine. This work is protected by U. S. Copyright Law. Unauthorized use including reproduction for redistribution requires the permission of the copyright holder. For more information, please contact scholarsmine@mst.edu.

Department of Structural Engineering
School of Civil Engineering
Cornell University

ANALYSIS OF LIGHT GAGE STEEL SHEAR DIAPHRAGMS

A Research Project Sponsored by
The American Iron and Steel Institute

Progress Report

by

Albert R. Ammar

Project Director

Arthur H. Nilson

Ithaca, New York

January, 1971

TABLE OF CONTENTS

1.	INTRODUCTION.	2
2.	REVIEW OF PREVIOUS STUDIES	4
3.	PURPOSE AND SCOPE OF THIS INVESTIGATION.	11
4.	EXPERIMENTAL INVESTIGATION.	13
	4.1 - General.	13
	4.2 - Equipment and Instrumentation.	14
	4.2.1 - Connections Testing Machine.	14
	4.2.2 - Panel Testing Set-up.	18
	4.3 - Test Results.	21
	4.3.1 - Connection Tests.	22
	4.3.2 - Panel Tests.	25
	4.4 - Discussion of Experimental Work to Date.	28
5.	ANALYTICAL INVESTIGATION.	32
	5.1 - General, Basic Assumptions.	32
	5.2 - Structural Idealization of the Diaphragm.	33
	5.3 - Proposed Method of Analysis.	35
6.	PLANNED CONTINUATION OF THE PROGRAM.	40

List of Figures

- Fig. 1 - General View of Connections Testing Set-up (Photograph)
- Fig. 2 - Top View of Connections Testing Apparatus (Photograph)
- Fig. 3 - Connections Testing Apparatus - Plan View
- Fig. 4a- Section A-A for Welded Sidelap Connections
- Fig. 4b- Section A-A for Screw Fastened Sidelap Connections
- Fig. 4c- Section A-A for Screw Fastened Edge Connections
- Fig. 5 - General View of Panel Testing Frame (Photograph)
- Fig. 6a- Panel Testing Frame - Plan View
- Fig. 6b- Panel Testing Frame - Sections and Detail
- Fig. 6c- Panel Testing Frame - Details of Attachments and Panel Supports
- Fig. 7 - Details of Loading Devices for Panel Testing
- Fig. 8 - Load vs. Slip for Welded Sidelap Connections
- Fig. 9 - Load vs. Slip for Welded Sidelap Connections
- Fig. 10- Load vs. Slip for Welded Sidelap Connections
- Fig. 11- Load vs. Slip for Welded Sidelap Connections
- Fig. 12- Load vs. Slip for Welded Sidelap Connections
- Fig. 13- Comparison between Welded Sidelaps, Flat-up and Flat-down
- Fig. 14- Load vs. Slip for #14 Screw Fastened Sidelap Connections
- Fig. 15- Load vs. Slip for #10 Screw Fastened Sidelap Connections
- Fig. 16- Comparison between #14 and #10 Screw Fastened Sidelap Connections
- Fig. 17- Load Vs. Slip for #14 Screw Fastened Edge Connections

- Fig. 18- Load vs. Slip for #10 Screw Fastened Edge Connections
- Fig. 19- Comparison between #14 and #10 Screw Fastened Edge Connections
- Fig. 20- Variation of Ultimate Shear Capacity with Material Thickness for Welded Connections
- Fig. 21- Variation of Ultimate Shear Capacity with Welded Length for Welded Connections
- Fig. 22- Variation of Ultimate Shear Capacity with Material Thickness for Screw Fastened Connections
- Fig. 23- Comparison between #14 and #10 Screw, for Ultimate Shear Capacity of Screw Fastened Connections
- Fig. 24- Comparison between Ultimate Shear Loads of Edge and Sidelap Screw Fastened Connections
- Fig. 25a Deformations of Corrugated Panel under in-plane Longitudinal Load
- Fig. 25b Deformations of Corrugated Panel under in-plane Longitudinal Load
- Fig. 25c Deformations of Corrugated Panel under in-plane Longitudinal Load
- Fig. 25d Deformations of Corrugated Panel under in-plane Longitudinal Load
- Fig. 25e Deformations of Corrugated Panel under in-plane Longitudinal Load
- Fig. 25f Deformations of Corrugated Panel under in-plane Longitudinal Load
- Fig. 25g Deformation of Corrugated Panel under in-plane Transverse Load
- Fig. 25h Deformation of Corrugated Panel under in-plane Transverse Load
- Fig. 25i Deformation of Corrugated Panel under in-plane Transverse Load
- Fig. 25j Deformation of Corrugated Panel under in-plane Transverse Load
- Fig. 25k Deformation of Corrugated Panel under in-plane Transverse Load

1. INTRODUCTION

It has long been recognized by structural engineers, that light gage steel cladding floor and roof decking systems have a considerable stiffening and strengthening effect on building frameworks. The beneficial contribution of these diaphragm systems is most pronounced when the structure as a whole is subjected to loads which result in an in-plane shear action of the cladding. This occurs, for example, when the rigidity of a floor or roof diaphragm acting as a membrane is utilized to transmit lateral forces to stiff end walls. Another example of diaphragm action is found in pitched roof portal sheds under vertical and lateral loads. In such cases the membrane strength and rigidity of the cladding can be used to restrict the tendency of intermediate frames to sway, by transferring the load to end walls and resulting in substantial economy in the design of the frames. Specific utilization of the in-plane shear strength and stiffness of panelling was suggested more than 18 years ago, but unless this effect could be calculated in advance no practical use could be made.

In order to take this contribution to stiffness and strength into account in engineering design, it was necessary to develop means for predicting the effective shear rigidity and ultimate strength in shear of the steel panel diaphragm. Because of the complexity of such diaphragm systems, up to now, engineers have relied upon

tests of full-scale-panel assemblies, in which the performance of specific combinations of panels, marginal framing members and connections have been studied on a strictly ad hoc basis. While much has been learned using this approach, and valuable design information was obtained, no rational theory to describe and predict structural behavior has resulted.

On the other hand, testing of large full scale diaphragm installations is expensive and time consuming, and tests results are applicable only to identical assembly using the same panels as tested, with directly equivalent fastening systems. The need for a general method of analysis is clear.

2. REVIEW OF PREVIOUS STUDIES

After qualitative recognition of the stiffening effect of diaphragms, there was need for a means to measure or evaluate quantitatively the stiffening contribution of this type of installation to the structure as a whole.

Historically, as indicated by Nilson (3), it appears that the first tests related to diaphragms were performed in California in 1947 by C. B. Johnson and F. J. Converse; the panels used were of the corrugated box-ribbed type and the test consisted of pulling with cables on a full sized building. In the early 1950's, Johnson (1) presented some interesting structural theory pertaining to diaphragm action, summarizing the information available then, and hoping for more research and experimentation in that field. As mentioned in reference (3), a second group of tests was performed in 1950 by S. B. Barnes, with cellular type panels (flat plate stiffened by hat sections). However, the results of the investigation remained in an unpublished report.

The tests mentioned constitute a start, 20 years ago, for research in the field of diaphragm action. A rebirth of interest in the study of the membrane action of deck installation is indicated by the systematic testing program initiated in 1955 by Nilson and Winter of Cornell University.

The study carried out by Nilson (2), (3) was primarily experimental in nature, it disclosed the many factors which influenced the performance of diaphragms, stressing

the importance of the connections, establishing the difference between seam and edge connections and describing welding techniques developed for purpose of standardization. The deformational response of the installation to load was also analyzed and a separation made between the deflection caused by shear deformation of the material itself and that due to the relative displacement at the connectors as well as that due to flexure. As a result of this systematic study, a testing technique was found for evaluating the shear rigidity of a diaphragm, which has been widely adopted thereafter as a standard procedure. A description of the testing procedure is given in the manual published by AISI (9)

In their works, Bryan and El-Dakhkhni, (4), (5), made use of the stiffening effect of the cladding material in the analysis of sheeted portal frames. Shear rigidity of the sheeting is established by test using the technique described by Nilson (3), and assuming an average constant value for an effective shear modulus the analysis includes the stiffening effect of the cladding. A comparison is made between the deformation of the system with and without diaphragm action.

Because of the many parameters influencing the behavior of the complex diaphragm installations, and in order to study their effect, a second extensive experimental program was undertaken at Cornell. Work by Luttrell (6) and Apparago (7) investigated and explored the contribution of

each variable to the over-all load-displacement response of the diaphragm, with particular emphasis on open corrugated panels. More than one hundred diaphragm installations were tested, in which many factors were examined: type of panel sheet, size of panel, type, spacing and arrangement of fastening devices, effect of purlins; size of marginal framing beams and many possible combinations of these variables. The effect of repeated loading was also studied.

As a result of this research, some conclusions regarding the most important factors involved could be drawn and were summarized by Luttrell (8). It was found that the size of the panels is not an important factor and the same could be said about the size of the framing beams. The ultimate capacity of the diaphragm seemed to vary almost linearly with the material thickness. For the load-displacement curves a linear behavior up to 40% of the ultimate was considered a good approximation in most of the cases. It was also found that diaphragm behavior is most sensitive to connection types and patterns. No general theory was deduced, emphasizing the fact that results could not be extrapolated and should be applied only when analyzing similar installations.

For the design profession, charts were established to evaluate the shear stiffness of diaphragm installations, and guide lines plus recommendations for design were developed and published by AISI (9).

Tests of diaphragm installations have been made on various occasions since. While little test information has been published in the technical literature, a considerable amount of information is generally available from the manufacturers of the panel units which have been sponsors of most of these tests.

While the experimental approach of the problems, provided the engineering profession with the needed information for design, and constitutes a valuable asset, it suffered from lack of generality and pre-required the performance of large-scale testing. A different point of view was adopted in England by Bryan and Jackson (10) who tried to establish the stiffness characteristics of a corrugated box ribbed panel by derivation from initial geometry, applying energy principles and assuming uncoupling of the different effects. The method, although attractive, because of its relative simplicity led to somewhat disappointing results.

An extension of this approach was described by Bryan and El-Dakhakhni (11), (12). The study is based on the central assumption that the flexibility of the diaphragm installation could be evaluated by merely adding (using simple summation) the individual flexibilities of the different components. Some of the flexibilities, as for the panels, are obtained by analysis of a single corrugation using simplified assumptions and energy

principles; the rest of the flexibilities are obtained by tests. Some comparisons are made with experimental data obtained from actual installations.

A more sophisticated approach regarding the derivation of panel flexibility, and applying the same energy principles but with more rigorous concepts, by Libove and Lin (13) was not more accurate in correlating the analysis with the experiments.

Parallel to the studies undertaken to analyze and predict the behavior of diaphragm installations as shear webs, use of light gage steel panels has been made in other aspects of structural engineering. To mention only a few, Nilson (14) reports the use of cellular deck type panels in folded plate roof structures. Use of corrugated sheets in steel hyperbolic paraboloids was proposed by Nilson (15) and exploratory test made in 1962. Continuous research at Cornell in the use of steel decks of thin walled sections in Hypar structures led to the publication of Gergely and Parker (16). A recent study dealing with the analysis of thin steel hypar shells is described in the paper by Banavalkar and Gergely (17).

A great amount of research was also directed toward the use of diaphragms as bracings for columns. Papers by G. Winter (18) and a discussion of his findings by Larson (19) initiated an intensive program in that area. Works by Pincus and Errera (20) and later by Apparao (21) established the beneficial effect of diaphragm bracing

on column stability. Though analytical formulation for bracing is presented, the shear rigidity of the diaphragm bracing material is still obtained by means of standardized cantilever test. Research in this domain which started at Cornell in 1960 is still under way, exploring the many facets of the problem.

A different aspect of the investigation of diaphragm behavior is related to the strength of the system. In this type of installations the ultimate load carrying capacity is either dictated by the strength of the connectors or, when this is more than sufficient, by the elastic buckling of the diaphragm as a whole.

The elastic stability of thin plates under the action of pure shear, has been investigated many years ago, and related works described in Timoshenko's book, "Theory of Elastic Stability" (22). Further investigations of the problem, considering more realistic boundary conditions, were undertaken by Bergman and Reissner (23). The interest of the aerospace industry in the buckling, as well as the post-buckling strength of light gage sheets, under the action of shear, promoted much research in that area. The work by Seydel (24) is considered a reference of prime interest with regard to that subject. The work by Smith (25) is a good treatment of long corrugated plates (with clamped edges) under the action of uniform shear; it constitutes an extension of the works previously mentioned. The book by Kuhn (26) con-

tains a good list of references for the analytical treatment of the question, and in addition presents solutions for practical problems faced by the aircraft industry in conjunction with shear buckling and the application of the theory of diagonal tension. Some test results are also described and analyzed.

A more recent treatment of the shear buckling of plates is given by Hlavacek (27), (28), which extended the solution of the problem to markedly orthotropic thin plates subject to uniform shear load along the edges. A particular interest is given to post-buckling strength and behavior. The papers also contain charts to account for the influence of the most important factors.

A paper by Easley and McFarland (29) constitutes a treatment of the buckling of open corrugated section panels using both the small and the large deflection theories. The approach, which is similar in many aspects to that adopted by Hlavacek, considers a deflected shape function, with inclined half-sine buckling waves. It recognizes the orthotropic nature of the panel in bending, and contains formulas to evaluate predicted buckling loads. Correlation with experiments is within 15% to 30%. A discussion of the paper by Nilson (30) stresses some interesting points relative to the analysis and correlates the experimental results with the formulations proposed by Hlavacek (27).

3. PURPOSE AND SCOPE OF THE INVESTIGATION

The present research is directed toward the development of a rational method for the analysis of shear diaphragms fabricated from standard light gage steel roof sheets or floor panels. This method would provide means to determine stresses, deflections, and ultimate strength of shear diaphragms, minimizing the need for further large scale testing of proposed systems.

The approach taken is based on the finite element concept, developed in the aerospace industry, and now finding many applications in the field of civil engineering structures. The proposed method of analysis, which involves the idealization of the structure into an aggregation of smaller units interconnected only at discrete points, is most appropriate in the case of diaphragm installations. Each of the structural components of a given metal deck diaphragm (i.e. the individual deck panels, the purlins, the marginal framing members and the different type of connectors) is taken as a discrete element, the stiffness characteristics of which are established either by analysis or by experiments. The contributions of the individual component parts are then combined analytically to form the global stiffness of the structure. The use of standard matrix formulations together with the solution of the resulting algebraic equations by digital computer leads to a rapid solution of the problem i.e. determination of the response of the entire assemblage when subjected to

loading.

Because of the complex nature of some of the components involved, and the difficulty in establishing their mechanical properties on purely analytical grounds, small-scale tests will undoubtedly be required to provide stiffness and strength characteristics of typical components, where this information is not already available.

One of the goals of the present research work is to establish for panels and connectors, a set of simple standardized test procedures, and to use these test techniques to produce representative stiffness and strength properties for system components. The experimental investigation will exclude any large-scale diaphragm tests such as have been done in previous studies. However full use will be made of existing information of that type.

A second goal of the research is to develop the analysis to the point that a general purpose computer program can be made available to the design profession for the analysis of diaphragms. While experimental verification of any analysis is essential, sufficient experimental data is available now, as the result of prior testing, to permit comparisons for many types of installations.

4. EXPERIMENTAL INVESTIGATION

4.1 General

Among the many tools available to modern structural analysis the direct stiffness matrix method of analysis constitutes a broadly useful technique for the solution of complex structures. Once the stiffness of the respective structure components is known, it is generally easy to formulate the problem and, using matrix algebra, to find the required solution i. e. to determine the response of the structure as a whole to applied loads. However, in the case of diaphragms because of the nature of its components and their particular geometries it becomes very difficult and sometimes almost impossible to derive analytically, from purely theoretical considerations, the needed rigidity characteristics. In such cases and instead of advocating some rather idealized assumptions it seems to be more advisable to obtain the required information by means of experiments.

The main components of diaphragm systems are the panel sheets, the purlins, the marginal beams and the different fastener types connecting the components together into one system. The marginal beams being generally of standard sections and regular shapes, their contribution to the stiffness of the system can be evaluated rather easily by making use of basic strength of material principles and standard matrix formulation. However, this is not so in the case of panel elements or when one tries to express

the behavior of a particular type of connection.

The goal of the experimental investigation in this research project is to establish, for panels and connector types, a set of simple test procedures; and to use these test techniques to produce representative stiffness and strength properties for the different components of diaphragm systems. These test methods have been developed with the view that they should constitute standard tests, to be applied in the future to many types of components. Particular consideration was given to achieving test arrangements of a versatile nature, to allow for possible variation in the components investigated.

4.2 - Equipment and Instrumentation

The experimental investigation focused on the development of two standardized tests, the first relating to the performance of typical welded or screw fastened connections and the second relating to the deformational characteristics of typical panels of standard geometrical configuration subject to in-plane loading.

4.2.1- Connection Testing Machine

Anticipating the idealization of fasteners in the analysis in the form of a link with a variable spring constant $k=k(d)$, experimental knowledge is required of the force-displacement behavior of the connection. Once the S-d relation is obtained by testing, an expression for the stiffness k of the connection can be obtained in

terms of either the force or the displacement. Bearing that in mind, a specially designed testing machine was developed.

A view of the set-up for the testing of the connections is shown in Fig. 1. The set-up consists of the testing apparatus itself resting on a relatively stiff, wide flange I-beam against which the load is applied to the specimen tested. Loading is provided by means of a hydraulic jack, and the load intensity measured by a load cell. The relative displacement of the two parts of the connection tested is measured using dial gages with a precision of 1/1000 inch. With this arrangement the set-up constitutes a self-sufficient independent testing unit.

A top view of the testing apparatus itself is shown in Fig. 2, whereas its in-plane dimensions are given in Fig. 3. The specimen representing a given type of connection is generally composed of two parts (two light gage steel sheets or a sheet and a hot-rolled flat section) attached together by an appropriate fastener. The two parts of the specimen to be tested are each clamped between two flat heavy plates (the arm) using high strength bolts to provide a friction type attachment. By this means, the load is transferred to the specimen by friction alone, avoiding stress concentrations or local distortions that could result from the bearing of the bolts on the relatively thin sheeting. The form of the arms is such to produce co-linear self equilibrated forces inducing a shear type

loading on the connection. Through the use of guide tracks, the flat plates are allowed to move in their own plane only, and in the direction of the load. Teflon pads are used along the guide tracks to reduce friction to a negligible minimum. The geometry of the apparatus was designed to eliminate undesirable eccentricities and restrain out-of-plane displacement, restricting the movement to that which is obtained at a connection in an actual diaphragm installation.

Figures 4a, 4b and 4c represent the cross section of the testing machine for welded and screw fastened connections. These illustrate the versatile possible arrangements for the apparatus. In the case of welded sidelap connections, Fig. 4a, where the specimens intend to represent panel-to-panel seam connection, two types of welding modes were tested:

- a) Welds at the level of the hook (used in cellular type decks) resulting in an eccentric attachment with respect to the flat plate (and further referred to as weld flat plate down).
- b) Welds at the level of the flat plate, the welding connecting the two sheets directly (further referred to as weld flat plate up).

Figures 4b and 4c, show the arrangement used in testing screw fastened connections. Figure 4b refers to sidelap screw connections representing sheet-to-sheet seams along the panel edges. In this case the two flat portions of the specimen overlapped by 1 1/2 in. and are

attached by one self-tapping screw. Spacers having the same thickness as the light gage steel sheets are also introduced to achieve centering of the specimen in the testing machine.

Figure 4c illustrates the arrangement used to simulate edge connections (i.e. fastening of the panel edge to the flange of a marginal beam.) Here one part of the specimen is a thin light gage steel sheet whereas the other part is a flat rolled plate $5/16$ " thick. Again the overlapping is $1\ 1/2$ " and the attachment realized by means of a self-tapping screw. For adequate centering of the specimen, the spacers have different thicknesses, one equal to $5/16$ " and the other to the sheet thickness itself.

A similar set-up will be used later on to simulate edge welded connections and obtain the characteristic behavior of such attachments.

The testing procedure was the same for both welded and screw fastened connections. After appropriate centering of the specimens and adequate clamping between the arms, the assemblage of arms and specimen is placed on the tracks, the drawing bars attached and the dial gages put in place. First a relatively small load is applied and released to produce initial fit. Load is then applied by increments amounting to approximately $1/10$ of the expected ultimate. Displacements at both ends are recorded for every increment. The incremental load was

smaller for higher loads. The ultimate shear load is recognized as the highest load reached and the ultimate relative displacement (slip) is the one associated with that load. Loading beyond that point has resulted in very large displacements for consistantly dropping values of the load carrying capacity of the specimen.

4.2.2. - Panel Testing Set-up.

If one has to establish the mechanical properties of a given panel by experimental means, it is obviously easier to get the flexibility of the panel i.e. its deformational response under the action of a unit load, than to obtain its rigidity. Consequently the efforts have been directed toward the establishment of a flexibility matrix for the panel using testing procedure, bearing in mind that the required stiffness matrix of the panel is to be derived from the flexibility by appropriate matrix transformation.

in order to test the flexibility of light gage steel panels, a special testing set-up was designed and built and is shown in Figure 5. The set-up consists essentially of a horizontal rectangular frame, made of two heavy 8" channels, which rests on two longitudinal steel I-beams and can provide both horizontal supports and load reaction to the panel to be tested. The size of the frame is such to accomodate panels up to 3 feet in width and up to 9 feet in length. The detailed dimensions of the frame are given in the plan view Figure 6a and the related sections

in Figure 6b.

The panel to be tested lies horizontally inside the frame and rests also on the two I-beams. It is restrained from rigid body motion in its plane by appropriate horizontal supports, linking the panel to the frame and resulting in a statically determinate support system for the panel. Special attention has been paid in the design of this attachment to simulate the actual conditions of a hinge support and a roller, in restricting the longitudinal and transverse displacements at these points but allowing for free rotation of the panel. Details of these attachments are shown in Figure 6c.

Because of the relatively thin material used in the fabrication of light gage steel panels, direct loading of the panel by means of shear type connectors is excluded to avoid local distortions, and friction type connectors are used instead, to transfer the external in-plane load to the panel. These are steel blocks attached to the panel edge by high tension 1/2" bolts. The application of in-plane loading to the panel is made through these blocks which are fixed at specific points (nodes) corresponding to connection locations in an actual diaphragm. The load is provided by a hydraulic jack acting against the frame and the load intensity is measured by means of a calibrated draw bar (with 4 SR-4 Electric Strain Gages) acting as a load cell in this case. Loads are applied either longitudinally (parallel to the

corrugations) or transversally (perpendicular to the corrugations); one load being applied at each node and in either direction in turn. Figure 7 shows the loading devices used to apply the load in each of the two mentioned directions.

Because of the nature of the panel on one hand and the purpose of the experiment on the other, a definite testing procedure is developed. First it was kept in mind that the main reason for the panel testing was the establishment of its flexibility under load. That is why the loading was not carried to failure or even to a level that may have caused permanent deformation of the panel.

In the case of corrugated sheets, the panel exhibits more rigidity to longitudinal loads as compared to transverse ones. Subsequently, the intensity of the load is planned to be different in the two directions being much higher parallel to corrugations. The value of the maximum load to be applied in each case is deduced from preliminary pilot tests, being also bound by previous knowledge of the ultimate shear capacity of related sidelap connections.

In loading the panel, special attention is paid to assure that the loading is acting in the desired direction only. Check of parallelism or orthogonality of the loading device with respect to the panel edge is routinely made prior and on the application of the first load. This first applied force is of small magnitude and

is intended to produce initial fit; after its release and reading of the respective zeroes on the dial gages. Load is applied by increments amounting to $1/5$ to $1/4$ of the desired maximum. This incremental procedure, although not imperative, is adopted to check the linear response to load.

For each loading situation, the displacements at the nodes in both the longitudinal and transverse directions are measured. These represent the flexibility column vector pertinent to that applied load. This vector is then normalized to correspond to a unit load. The assemblage of all normalized displacement vectors due to unit loads at all nodes forms the required flexibility matrix for the panel under consideration. This flexibility matrix is later on inverted and boundary conditions eliminated to form the stiffness matrix of the panel.

The panel testing frame has been used so far to obtain the stiffness of corrugated panels and will later be used to provide data for other panel configurations.

4.3 - Test Results

In studying connection behavior, the variables included material thickness of panel steel, length of weld, orientation of joints, and size of screw fasteners.

Tests of welded connections are grouped in two series: 1) welds flat-up and 2) welds flat-down. For the first series material thickness of 14 and 18 gage are used, with 1" and 2" welds. The second series of

welded connections included three material thicknesses (14, 16 and 18 gage) and three weld lengths (1", 2" and 3"). As a rule three specimens are prepared for each combination of the variables mentioned above, however, only two specimens are tested, the third being used only when scatter of results appeared to warrant more data.

For the screw fastened connection three material thicknesses (22, 26 and 30 gage) and two self-tapping screw types: #14 with back-up neoprene washer and #10 screw (without washer), were used. These connections were tested in two series, the first related to side-laps (sheet to sheet connection) and the second to edge connections (light gage sheet to relatively thick hot-rolled section). For every combination of the mentioned variables three tests were performed, except that four tests were found to be necessary in the case of 30 gage material, because of the relatively greater scatter in the results.

Panel testing to date has included a 2' x 8', 30 gage material, standard panel with 2 1/2" x 3/4" corrugations. Twelve nodes were established, six along each edge, spaced 1'-6" apart.

4.3.1. - Connection Tests

Tables 1 and 2 summarize the results obtained in tests of both welded and screw connections. Table 1 includes welds with flat plate up and welds with flat plate down; Table 2 includes sidelap screw fastened

connections, and screw fastened edge connections for both #10 and #14 self-tapping screws.

The ultimate load S_u is the highest load reached, and d_u is the relative displacement associated with that load. In some cases failure closely followed attainment of S_u , by physical separation of the two parts of the connection. In other cases, very large deformation took place after reaching S_u with gradually decreasing load. However, this descending portion of the S-d curve is strongly influenced by the relative stiffness of the specimen and the loading apparatus, and is of little practical interest since it is associated with unacceptably large deformations representing almost zero stiffness for the connection.

Complete load-displacement behavior, from zero load to the ultimate load S_u , is given for representative connections. Graphical results for welded connections, are given in Figures 8, 9, 10, 11 and 12. The first three figures are related to welded hook joints used in the conventional position, flat plate facing down. Each figure groups the connections according to the weld length (3", 2" and 1" in turn) and illustrates the effect of varying the panel sheet thickness. Figure 8 refers to 3" weld length, Figure 9 to 2" weld length and Figure 10 to 1" weld length, in each case the material thickness varied between 14 and 18 gage. It is seen that the curves have the same characteristic shape and could be said to be

homologus.

The behavior of welded connections with the flat plate in the upward facing position is illustrated by Figures 11 and 12. In this case, the weld joins the flat shear carrying panel sheet directly, rather than at the top of the hook joint, resulting in substantial increases in both stiffness and strength; in addition, with this type of welding technique it is far easier to produce a satisfactory and reliable weld. Here again the results are grouped according to weld length: Figure 11 refers to 2" weld length and Figure 12 refers to 1" weld length. The material thicknesses tested in this case were 14 and 18 gage. Figure 13 compares the performance of a 2" welded connection, with an 18 gage material, for the two positions of the flat plate previously mentioned.

Self-tapping screw connections were tested in two series, the one simulating sidelap (sheet to sheet) connections and the second edge connections (sheet to thick rolled section). For the first series, Figure 14 and Figure 15 describe the behavior, with #14 and #10 screws respectively, and for panel thicknesses equal to 22, 26 and 30 gage. Again a set of curves of similar shape is obtained, but without a definite tendency to be homologus. It is noted that these curves characteristically show a very limited range of linear behavior. Scatter of test results was greater for the screw-fastened tests than for welded tests, probably because of the relatively

flexible assemblies, and the possible variation in the screw fastening. In some instances, it was considered necessary to perform additional tests to assure a reliable average value of the results. Figure 16 contrasts the behavior of screw fastened sidelaps using #14 screws with those using #10 screws.

For the second series, Figure 17 and Figure 18 illustrate the load-displacement behavior of edge screw fastened connections, with #14 and #10 screws respectively and for panels of various thicknesses (22, 26 and 30 gage). The set of curves obtained is similar in shape to the one resulting from testing sidelap, however, the range of linearity is bigger, the connection exhibiting more rigidity and the ultimate shear carrying capacity being much higher. Figure 19 compares the behavior of an edge connection to that of a sidelap connection.

4.3.2. - Panel Tests.

The support configuration was chosen in such a way to produce tensile reactions when longitudinal forces are applied. To comply with that condition, the longitudinal forces are always applied in one direction, the one defined by that going from the hinge support to the roller.

Transverse loading was always directed from the panel outwards. Loads applied close to the supports (at nodes 5 or 11 for example) are to produce substantial compressive forces that could induce local buckling of the panel end. To avoid such secondary effect, which would

not occur in an actual diaphragm, the out of plane displacement of the panel ends is restrained by means of two wood blocks placed above and beneath the corrugation. These form a guide track allowing only for free in-plane movement. Polyethylene strips were used as pads to reduce friction to a negligible amount.

In addition to preliminary pilot tests that served the purpose of establishing the testing procedure to be followed and developing the system of instrumentation, results of actual testing of a standard corrugated panel have been obtained. The panel, of 30 gage material, was used with 12 nodes resulting in 24 degrees of freedom, which will finally reduce to 21 independent degrees of freedom because of the three restraints at the supports. Accordingly it was necessary to investigate twenty-one separate loadings to account for all the degrees of freedom of the panel.

The deformational behavior of the panels at the maximum applied load in every state, is given in Fig. 25a to Figure 25k. The results obtained from transverse loading of the panel are given in Figure 25g to Figure 25k. Because of the support configuration, transverse loads applied at the same distance from either of the supports must result in the same deformational behavior, due to topologic similitude. In fact, experimental results obtained confirm that statement and one can see that the shape of the deformed panel due to transverse

load at node 4, for example, agrees with that obtained by having the load acting at node 10. The same applies for the pairs 1 and 7, 2 and 8, 3 and 9, and 5 and 11.

It is interesting to note that the flexibility of the panel due to a transverse load is not the same everywhere. A Transverse load applied at the end corner of the panel will produce much more displacement, than the same load applied at mid-distance along the panel edge. This "end effect" is to be specially noted, since it contradicts any attempt to consider the panel as possessing a constant transverse rigidity.

Speaking of the states of longitudinal loading, the case of an applied load at the roller support is of particular interest. Again the forces acting on the panel at the two supports will be the same and we will have a topologic similitude. The results obtained clearly demonstrate that fact and one can recognize that nodes equidistant from the support exhibit the same deformational behavior.

In general longitudinal loads applied along the edge opposite to the roller support encounter more resistance, ending up in more stiffness for the panel, as compared with the case when loads act along the edge on the side of the roller. This is so because of the particular arrangement of the supports.

4.4 - Discussion of Experimental Work to Date

Summing up the results obtained to date in the experimental investigation, one can make some concluding remarks regarding the behavior of the connectors and the panels.

First, relative to the Welded Connections, the following may be tentatively concluded:

- a) The ultimate shear load capacity of a sidelap welded connection varies linearly with the material thickness. This was evident for the two weld positions investigated namely: welds flat plate up and welds flat plate down. Figure 20 is a graphic representation of that statement.
- b) Similarly, the ultimate shear capacity of a side-lap welded connection varies linearly with the weld length. Values for 1" nominal length of weld were higher than expected by the linear variation. This was explained by the fact that the actual effective length of these welds was bigger by 20%. Fig. 21 demonstrates the linear variation just mentioned.
- c) The experimental investigation has clearly proved that welded connections flat plate up (weld directly connecting the two flat sheets) are stiffer and stronger than those having the same combinations of variables, but positioned flat plate down. The increase in strength ranges

between 70% to 90%.

Commenting on this last finding regarding welded connections, one is inclined to attribute the difference in behavior to different modes of failure in the two cases above. A look at the specimens after testing suggests a different mechanism of fracture. In the case of welds flat down (where the seam weld is eccentric to the flat sheets), normal stresses due to local moment may be present in addition to shearing stresses. In almost all the specimens tested, the surface of separation is located just below and along the weld in the upward lip of the sheet for the hook type joint. The fracture suggests a separation mainly by shear, accompanied sometimes by local crippling of the vertical lip resulting in occasional wedging. This wedging occurs after the ultimate load capacity is reached and after large displacements have taken place, and has therefore no significant importance. When wedging occurs the two parts of the connection cannot be separated after failure. In the second case of welds flat plate up, failure starts by tensile separation in the vertical lip of the sheet, followed by shearing and tearing of the material along the weld. Shearing develops in both flat parts of the specimens, initiating at the opposite tips of the weld and progressing along and close to the weld in the two sheets. This shearing phenomenon appears after large displacements have taken place, and is believed to be a secondary effect.

For Screw Fastened Connections the following

observations were made:

- a) The ultimate shear load capacity of a screw fastened connection varies with the material thickness following an exponential law. This relation could be expressed in the following way:

$$(S_1)_u = (S_0)_u \times (t_1/t_0)^{\frac{4}{3}}$$

The subscript 0 expressing a reference thickness, S_u being the ultimate shear load and t representing the material thickness. This finding applies for both sidelap and edge connections. Fig. 22 illustrates that fact.

The use of this formula necessitates a pre-knowledge of $(S_0)_u$, the ultimate strength of a similar connection of reference thickness t_0 .

- b) Comparison of the ultimate shear load, for edge and sidelap connections relative to the size of the screw, showed an increase of 38% for #14 screw as compared to #10 screw, and as illustrated by Fig. 23. This increase is fairly consistent in the range of the material thicknesses tested. The ratio of the diameters of #14 and #10 screws is 1.36, suggesting a linear variation of the ultimate

shear capacity of the connection with the diameter of the screw.

- c) Edge connections are 80% stronger than their sidelap counterpart. This is so, for both #14 and #10 screw fastened connections (and for the range of thicknesses tested). A graphic illustration of that finding is given by Fig. 24.

It is thought that the increase in the load carrying capacity of the edge connections is due to the heavy plate restraining the tilting of the screw under load.

As for the Panel tested (a 30 gage steel standard corrugation 2' x 8' sheet), the deformational behavior obtained seems to be consistent with the type of loading, the support configuration and the orthotropic properties of the panel.

In addition to the nearly perfect matching of the deformations patterns for the topologically similar loading states, the repetition of some of the tests yielded identical results showing possible reproducibility and constituting a sound proof for the reliability of the results. Moreover, this gives some encouragement to proceed in using this method in future research.

5. ANALYTICAL INVESTIGATION

5.1 - General - Basic Assumptions

The complexity of steel panel diaphragms, which are fabricated of a large number of small parts, each able to move individually when the assembly is subject to loading, has up to now precluded the development of a proper theory of behavior. As mentioned before, in order to overcome the difficulties in analyzing the diaphragm as a whole, the present approach is to predict diaphragm response to load through knowledge of the structural performance of each component of the system.

As has been observed in many large-scale tests already performed, the connections play an important role in the behavior of the diaphragm, influencing both rigidity and ultimate resistance. Also based on experimental evidence and strain measurements on actual installations, it was found that the panel strains exhibit a linear dependence to load almost up to failure unless some disturbance is present due to local distortions. The failure of diaphragms is dictated by either the strength of the connectors, or when these are particularly heavy, by the elastic buckling of the whole metal deck installation.

Accordingly, a basic assumption of the analysis is to consider only a linear response for the panel, and to include the connection properties as the only source of non-linearity of the system. As the characteristic behavior of the different connection types could not be

properly represented by an analytical model, testing techniques were used instead, to obtain a complete load-displacement relationship for representative connections. The determination of panel stiffness from fundamental principles, by analyzing the deformational modes of initial geometrical configuration, has been disappointing so far and research works in this respect appeared to have serious limitations. Subsequently, two methods of approach have been selected to obtain the desired information about panel performance. The first is to adopt experimental techniques for the panel as well, to establish its flexibility matrix, appropriate matrix transformation being used to derive the required stiffness matrix. The second approach would explore the possibility of representing the panel continuum by an aggregation of orthotropic finite elements in order to derive the stiffness matrix by analytical techniques used in that field.

5.2 - Structural Idealization of the Diaphragm

The entire assembly of the diaphragm is decomposed, for the sake of analysis, into linear elements (purlins and beams) and shear elements (the panels) attached together at discrete points by the connectors.

It is assumed that the panel element has no resistance to bending effects, and will accommodate to the shape of the framing beams. These are considered to be linear members, connecting the extreme ends of the panels. Bending rigidity of the beam with respect to its

own axis is neglected in comparison to the bending stiffness of the flange beam with respect to the neutral axis of the assembly. The different sections of the marginal straight beams are hinge connected at the meeting point of two adjacent panels, and permitted to rotate, accounting for the bending deformation. The marginal beams are therefore represented by linear axially loaded segments.

The role of the purlins is assumed to limit the displacement of the panel intermediate ends. They will be idealized by the equivalent of a stiffening element of greater area at the connection of two panels. In addition of restricting panel deformations, the purlin will be considered in the capacity of transmitting axial internal forces similar to the situation of a stringer.

The panel is assumed to have no resistance to bending effects, being mainly acted by shear. However, rather than define it by a pure shear type element or even to consider a constant stiffness, the panel response to in-plane loading is derived from its actual behavior under test.

In the analysis two adjacent elements (panel-to-panel, or panel-to-purlin or beam) are connected together through a "linkage element" at the locations where fasteners actually exist. This linkage element represents the connector, and can be visualized as a non-linear spring, having its stiffness k varying as a function of the relative displacement d . That takes into account the shear action which takes place between the elements. Separation

between elements is considered only when the shear capacity is exhausted. For that reason, a very high value for the stiffness constant is taken for the linkage element perpendicular to shear direction, this value drops to zero when separation by shear occurs.

5.5 - Proposed method of Analysis

Using a direct stiffness type matrix formulation, and incorporating ideas from the method of substructures, a theoretical treatment of diaphragm behavior prediction now appears possible. At the present stage in the development of the analysis, panel and connection behavior is obtained by test where marginal beam behavior is derived from conventional strength of material type analysis. The three types of input information are assembled in the computer program to predict performance of the assemblage.

For the panels, the flexibility matrix $[F]$ is obtained experimentally by assembling the normalized column vectors of displacements due to all possible unit loads acting at the respective nodal points. For each loading situation a force vector is obtained representing the reactions at the supports. The support effect is eliminated by suitable matrix transformation to obtain the stiffness matrix of the panel. If we designate the flexibility matrix by $[F]$, and by $[R]$ the matrix obtained by assembling the force vectors of the support reactions (each column referring to one loading situation),

the stiffness matrix of the panel is given by:

$$K = \begin{bmatrix} [R].[F]^{-1}[R]^T & [R].[F]^{-1} \\ -[F]^{-1}.[R]^T & [F]^{-1} \end{bmatrix}$$

To approximate the experimental non-linear behavior of the connector, an expression of the form:

$$d = S_e \left(\frac{d_e}{S_e} \right) * \left(1 + \left(\frac{S}{S_u} \right)^{r-1} \right)$$

is presently used. This expression has the advantage of evaluating 'd', the displacement at any load level, in terms of measurable quantities S_e and d_e , the load and the displacement in the linear limit, in addition to the ultimate load itself. The linear displacement limit and related load is taken at 0.40 of the ultimate load in conformity with present A.I.S.I. recommendations (9). The value of the exponent r is evaluated for a given $S - d$ curve, from the best fit obtained in using the method of least squares. Other possible polynomial expressions are also tried. In addition, an attempt to simplify the representation by using a bi-linear or tri-linear diagram has proved to be promising. In that case, the whole range is subdivided into two or three zones for which a distinct constant stiffness expresses the connection performance. The stiffness constant "k" for every zone is given by the slope of the line; a zero value is assigned for "k" beyond the ultimate shear load.

Because of the relatively small contribution of the

bending stiffness of the marginal beams with respect to their own axis, the framing beams will be considered, for simplification, as flanges for the diaphragm, mainly acted by axial forces and possessing zero bending resistance. Further development of the analysis will consider the effect of bending rigidity as well. Purlins will be taken as stiffener for the panels, restricting their displacements, and acting as stringers subjected to axial forces.

Supplementing the experimental approach described to obtain the desired rigidities of the diaphragm components, a finite element technique will be also explored to derive the stiffness matrix of an individual panel. The panel itself is ideally represented by an assemblage of discrete finite elements possessing orthotropic properties corresponding to those resulting from the geometry of the actual panel. Only in-plane orthotropy is considered. The constitutive law of an orthotropic medium in a two-dimensional problem is given

by:

$$D = \begin{bmatrix} D_{11} & D_{12} & 0 \\ D_{21} & D_{22} & 0 \\ 0 & 0 & D_{33} \end{bmatrix} = \frac{1}{\lambda} \begin{bmatrix} E_x & \nu_x E_x & 0 \\ \nu_y E_y & E_y & 0 \\ 0 & 0 & \lambda G_{xy} \end{bmatrix}$$

where $\lambda = (1 - \nu_x \nu_y)$

Because of the fact that $D_{12} = D_{21}$, ($\nu_x E_x = \nu_y E_y$), the

constitutive law is defined in terms of four independent elastic constants. When the law is expressed by means of technical engineering parameters, these constants are recognized as: E_x and E_y the moduli of elasticity in the two principal directions of the medium, ν_x the poisson's ratio in one direction and G_{xy} the shear modulus related to the principal directions of the medium. These four constants have to be obtained in order to formulate the problem. For E_x and ν_x (relative to the direction along the corrugation) these are known from material properties or easily found. For G_{xy} , only a test of several pieces of panel (with same geometrical configuration) could provide the information. The same could be said relative to E_y (the apparent modulus perpendicular to the corrugations), however, E_y could be calculated (for a certain range of displacements which is of practical interest) making use of the initial geometry and applying energy principles.

Once in possession of the stiffness of the panels, the purlins, the framing beams and the connectors; the solution of the complete assembly of the diaphragm is based on an incremental loading approach coupled with an iterative process. For every increment of load the structure is analyzed and the displacements at the nodes calculated, based on the initial rigidities of the components. After each cycle the stiffness of the connector is revised and an iteration process introduced until it complies with the value associated with the current dis-

placement. At the end of each load increment a different global matrix is formed and a solution for the new system is sought. Another load increment is applied and the procedure repeated. The process continues until failure is obtained or some stability criterion is violated.

Following further study of solution techniques, the program will be expanded to permit handling of large order systems and will incorporate non-linear effects.

6. - PLANNED CONTINUATION OF THE PROGRAM

The work over the remaining months of the contract will be a direct continuation of that described.

A sufficient body of data has been already obtained relative to the performance of sidelap fasteners of several types (welds and screws) over a broad practical range of the variables of interest. Edge connections, in which the light gage steel sheet is secured to a section of heavier hot-rolled steel by means of self tapping screws have been also investigated. Further use of the connection testing machine will be to establish the properties of welded edge and end connections. Beyond this, no further connection tests will be made under the present project, although the testing apparatus will be available to establish a complete catalog of fastener characteristics if this should be desired.

The establishment of stiffness characteristics of typical panels will continue along two lines: a) through additional experimental investigation, using the panel testing frame b) by making use of available analytical tools for the idealization of the panel, as appear to be suitable.

A previously mentioned difficulty that was experienced in the testing of the panels has been overcome by appropriate improvement of the support attachments, and some modifications of the arrangement to restrain against incipient local buckling. The results already obtained,

and the experience gained made it possible to pursue the investigation in that direction without major problems. The determination of panel stiffness using analytical means will be given full attention, and the use of an orthotropic plane-stress finite element modeling of the panel will be tried.

The computer program will be developed, refined and expanded to permit a realistic representation of shear diaphragms. Systems simulating the cantilever type diaphragm or the "third-point loading" type will be analyzed incorporating experimentally derived characteristics of connectors and panels, as well as purlins and marginal members properties found by analysis. Comparative studies will be made correlating the prediction of the analysis with the observed behavior of diaphragms of both types tested in past work at Cornell and elsewhere.

List of References

1. C. B. Johnson, "Light Gage Steel Diaphragms in Building Construction", A.S.C.E. Meeting, Los Angeles, California, February 1950.
2. A. H. Nilson, "Deflection of Light Gage Steel Floor Systems under the Action of Horizontal Loads" M. S. Thesis, Cornell University, Ithaca, New York, 1956.
3. A. H. Nilson, "Shear Diaphragms of Light Gage Steel", Journal of Structural Division of A.S.C.E., Proc., Vol. 86, No. ST 11, Nov., 1960.
4. E. R. Bryan and W. M. El-Dakhakhni, "Behavior of Sheeted Portal Frame Sheds: Theory and Experiments", Proc. Institution of Civil Engineers, England, Vol. 29, December 1964.
5. E. R. Bryan and W. M. El-Dakhakhni, "Shear of Thin Plates with Flexible Edge Members", Journal of Struc. Division of A.S.C.E., Vol. 90, No. St 4, August 1964.
6. L. D. Luttrell, "Structural Performance of Light Gage Steel Diaphragms", Ph. D. Thesis, Cornell University, Ithaca, New York, September 1965.
7. T. V. S. R. Apparao, "Tests on Light Gage Steel Diaphragms", Report No. 238, Dept. of Structural Engineering, Cornell University, Ithaca, New York, December 1966.
8. L. D. Luttrell, "Strength and Behavior of Light Gage Steel Shear Diaphragms", Cornell Engineering Research Bulletin No. 67-1, Dept. of Structural Engineering, Cornell University, Ithaca, New York, 1967.
9. "Design of Light Gage Steel Diaphragms", American Iron and Steel Institute, New York, New York, 1967.
10. E. R. Bryan and P. Jackson, "The Shear Behavior of Corrugated Steel Sheeting", Symposium on Thin Walled Steel Structures, University College of Swansea, September 1967.
11. E. R. Bryan and W. M. El-Dakhakhni, "Shear Flexibility and Strength of Corrugated Decks", Journal of the Structural Division of A.S.C.E., Proc., Volume 94, No. ST 11, November 1968.
12. E. R. Bryan and W. M. El-Dakhakhni, "Shear of Corrugated Decks: Calculated and Observed Behavior", Proc., Institution Civil Engineers, Volume 41, November 1968, London.

13. C. J. Lin and C. Libove, "Theoretical Study of Corrugated Plates: Shearing of a Trapezoidally Corrugated Plate with Trough Lines permitted to curve", Report No. MAE 1833-T2, Dept. of Mechanical and Aerospace Engineering, Syracuse University Research Institute, June 1970.
14. A. H. Nilson, "Folded Plate Structures of Light Gage Steel", Journal of Structural Division of A.S.C.E., Proc., Volume 87, No. ST 7, October 1961.
15. A. H. Nilson, "Testing a Light Gage Steel Hyperbolic Paraboloid Shell", Journal of Structural Division of A.S.C.E., Proc., Volume 88, No. ST 5, October 1962.
16. P. Gergeley and J. E. Parker, "Thin-Walled Steel Hyperbolic Paraboloid Structures", International Association for Bridge and Structural Engineering, 8th Congress New York, 1968.
17. P. V. Banavalkar, P. Gergeley, "Analysis of Thin Steel Hyperbolic Paraboloid Shells", A.S.C.E. Water Resources Engineering Meeting, Phoenix, Arizona, January 1971.
18. G. Winter, "Lateral Bracing of Columns and Beams", Journal of Structure Division of A.S.C.E., Proc., Volume 84, No. ST 2, March 1958.
19. M. A. Larson, Discussion of G. Winter's Paper, (Reference 18), Proc., A.S.C.E., Volume 84, No. ST 5, September 1958.
20. S. J. Errera, G. Pincus, G. P. Fisher, "Columns and Beams Braced by Diaphragms", Journal of Structure Division of A.S.C.E., Proc., Volume 93, No. ST 1, February 1967.
21. T. V. S. R. Apparao, S. J. Errera, G. P. Fisher, "Columns Braced by Girts and a Diaphragm", Journal of Structure Division of A.S.C.E., Proc. Volume 95, No. ST 5, May 1968.
22. S. P. Timoshenko and J. M. Gere, "Theory of Elastic Stability", McGraw-Hill, New York, Second edition, 1961.
23. S. Bergmann and H. Reissner, Flugtech. u. Motorluftsch., Volume 23, p.6, 1932.
24. E. Seydel, Flugtech. u. Motorluftsch., Volume 24, p. 78, 1933. See also, NACA T.M. 602 (Translation).

25. G. E. Smith, "Elastic Buckling in Shear of Infinitely Long Corrugated Plates with Clamped Parallel Edges", M.S. Thesis, School of Aeronautical Engineering, Cornell University, Ithaca, New York, September 1957.
26. P. Kuhn, "Stresses in Aircraft and Shell Structures", McGraw-Hill, New York, 1956.
27. V. Hlavacek, "Critical Shear Stresses in Markedly Orthotropic Webs", Acta Polytechnica, Praha, January 1967.
28. V. Hlavacek, "Shear Instability of Orthotropic Panels", Acta Technica Csav, No. 1, Prague 1968.
29. J. T. Easley and D. E. McFarland, "Buckling of Light Gage Corrugated Metal Shear Diaphragms", Journal of Structure Division of A.S.C.E., Proc., Volume 95 No. ST 7, July 1969.
30. A. H. Nilson, "Discussion of Easley's Paper", (Reference 29), Journal of Structure Division of A.S.C.E., Proc., Volume 95, December, 1969.

TABLE 1 SUMMARY OF RESULTS OF WELDED SIDELAP CONNECTION TESTS

a) Welds Flat Plate Down

Gage Mat'l	Weld Length (in.)	Ultimate Load (lbs.)	Displacement at Ultimate Length (10 ⁻³ in.)
14		4300	185
16	1	3100	140
18		2600	120
14		6800	260
16	2	4950	190
18		4100	160
14		10000	300
16	3	7400	230
18		6400	200

b) Welds Flat Plate Up

14		8300	140
18	1	5000	120
14		11200	190
18	2	7600	140

TABLE 2 SUMMARY OF RESULTS OF SCREW FASTENED CONNECTION TESTS

a) Sidelap connections

Gage of Mat'l	Screw (No.)	Ultimate Load (lbs.)	Displacement at Ultimate Load (10 ⁻³ in.)
22		625	145
26	#14	410	140
30		260	135
22		480	135
26	#10	280	125
30		190	90

b) Edge Connections

22		1200	180
26	#14	750	150
30		450	150
22		920	150
26	#10	520	150
30		340	150



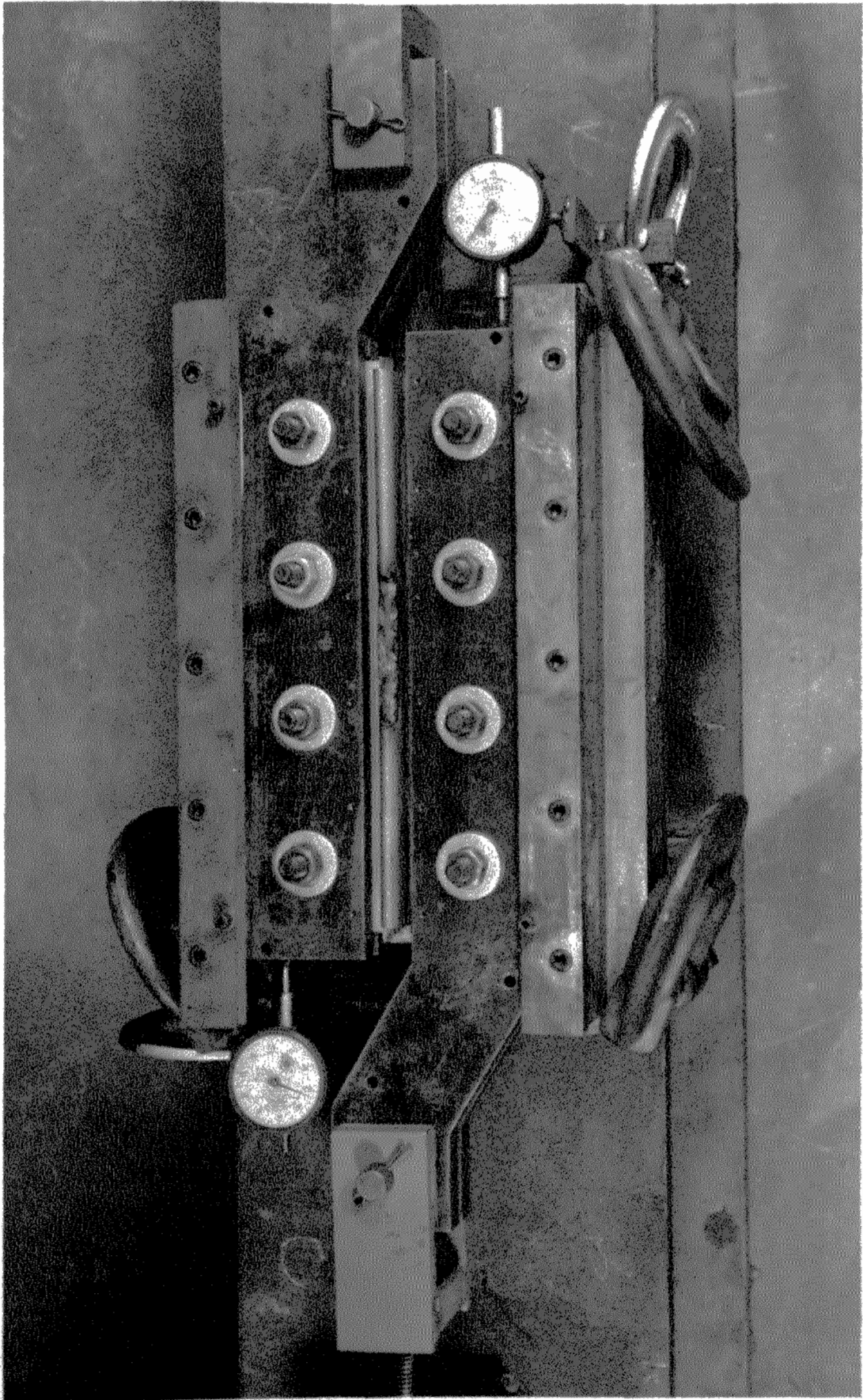

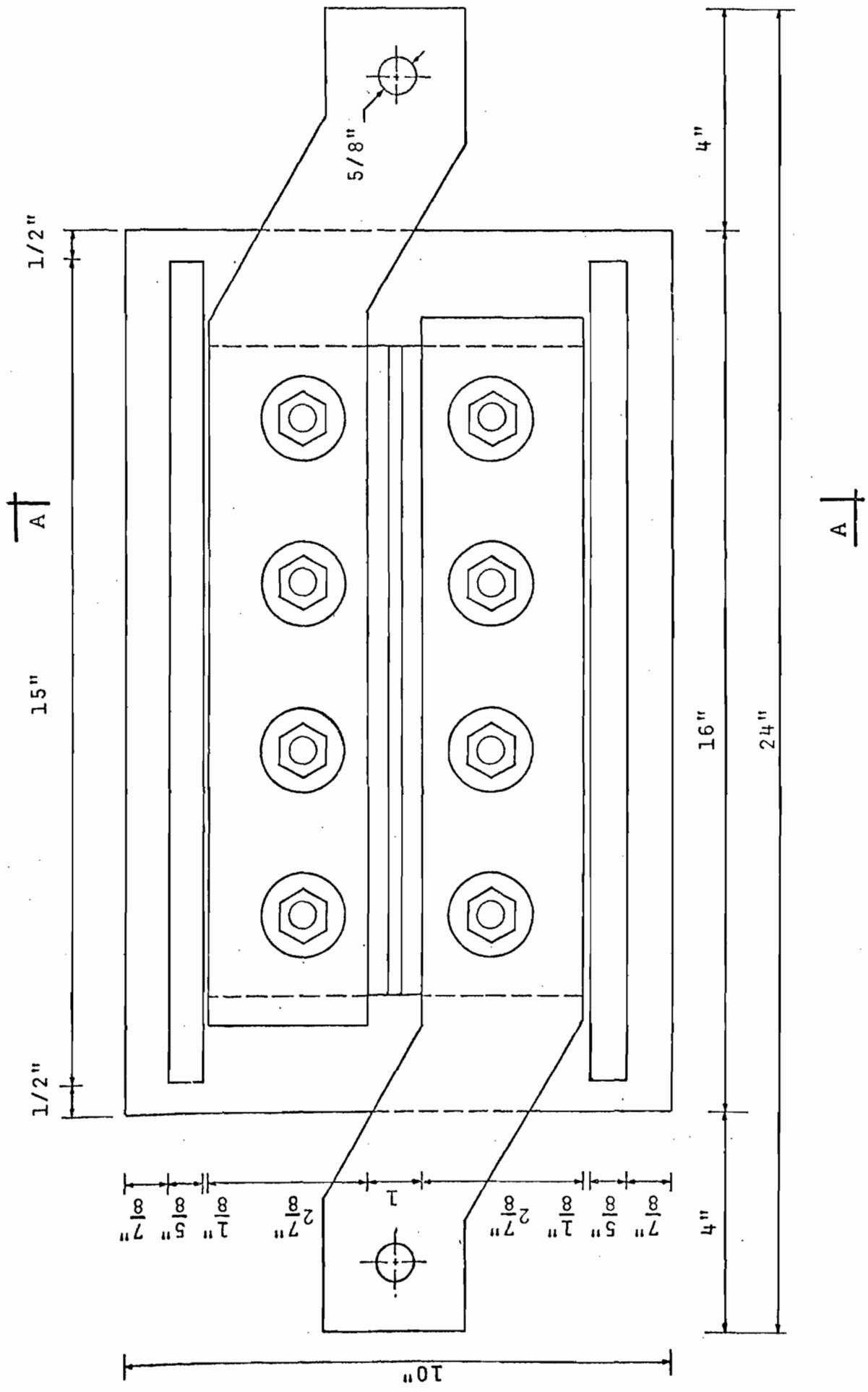

Fig. 3- Connections Testing Apparatus - Plan View

Welds Flat Plate Up

Welds Flat Plate Down

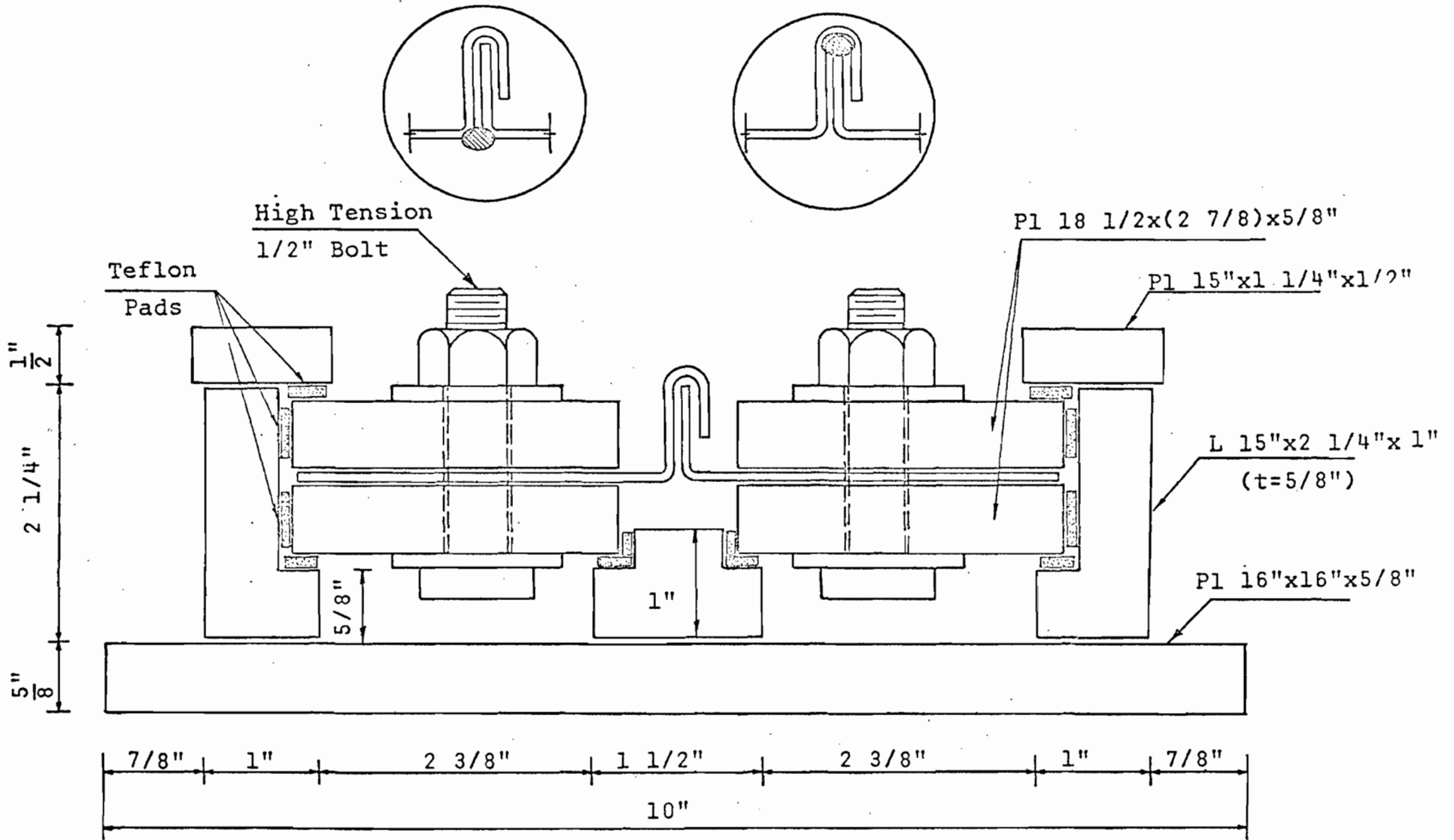

Fig. 4a- Section A-A for Welded Sidelap Connections

#14 Self Tapping Screw

#10 Self Tapping Screw

Steel Washer

Back-up Neoprene Washer

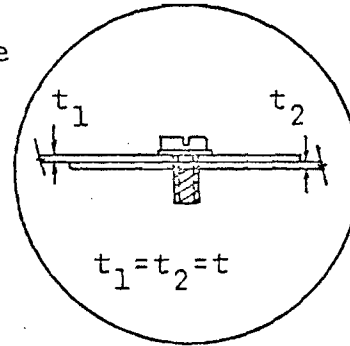
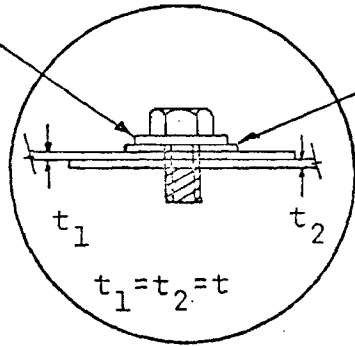

("t" varies)

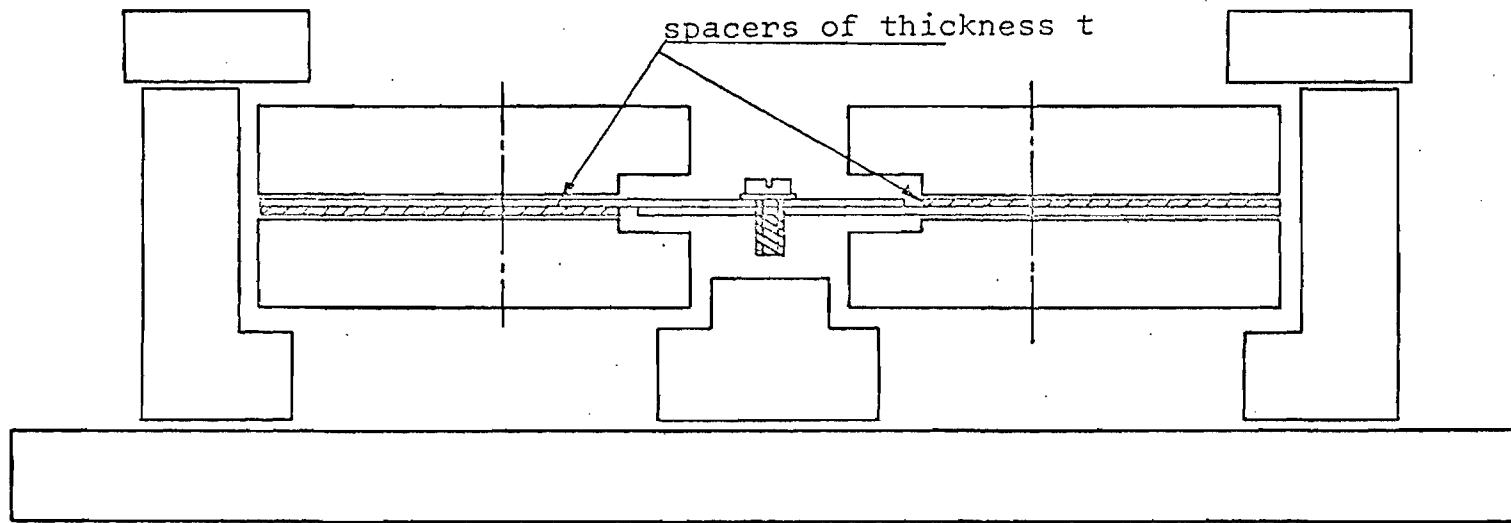

Fig. 4b - Section A-A for Screw Fastened Sidelap Connections

#14 Self Tapping Screw

#10 Self Tapping Screw

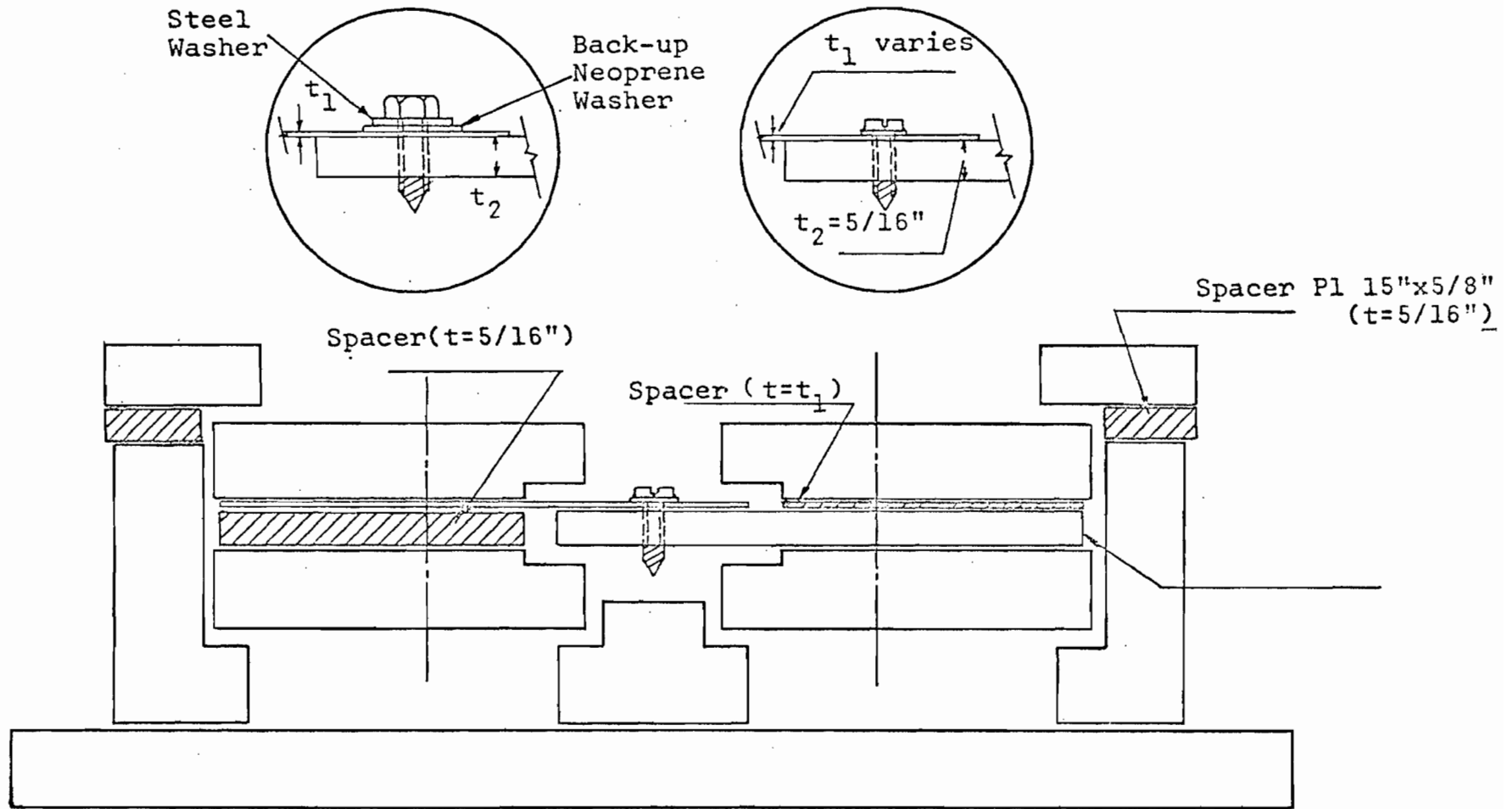
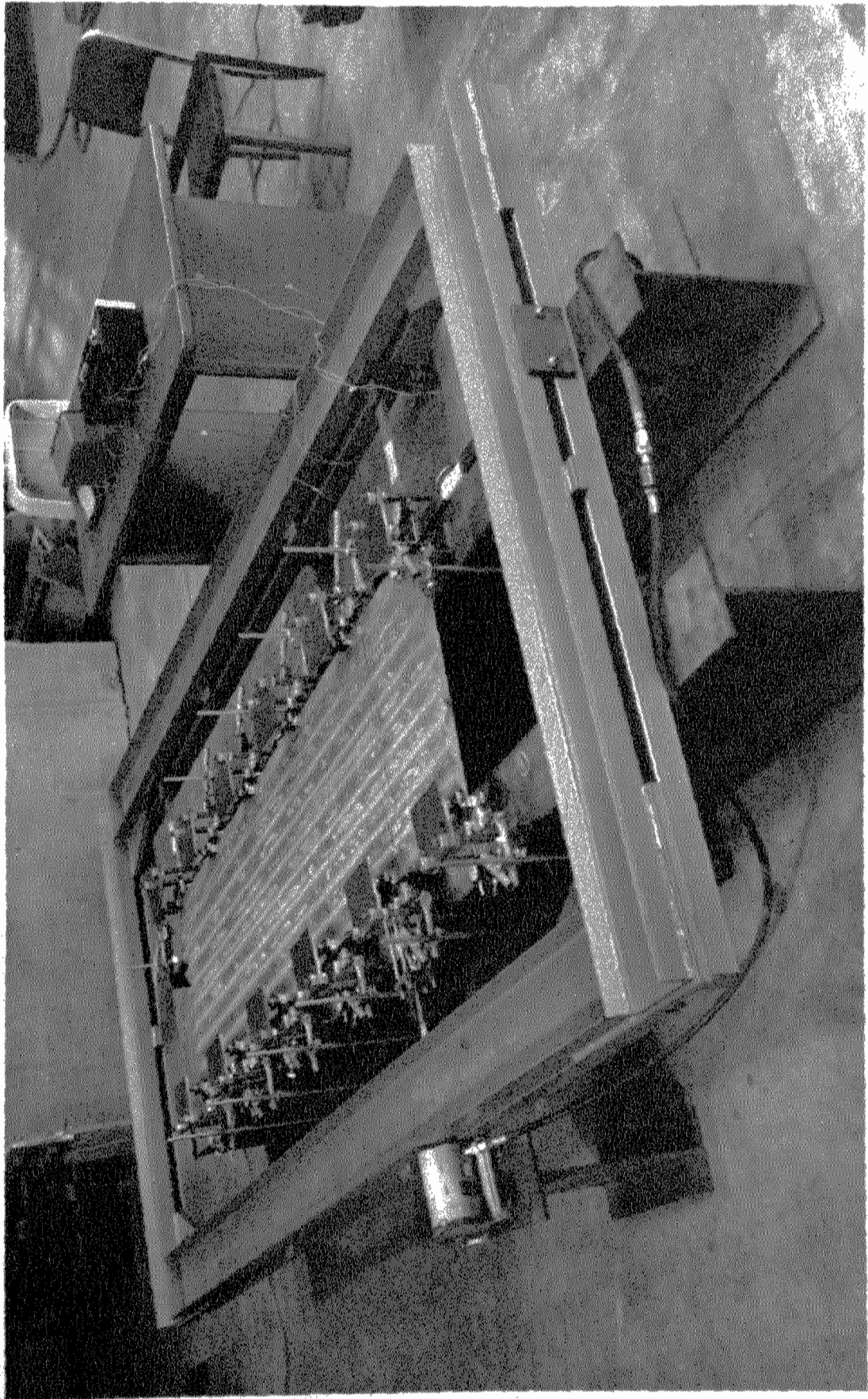

Fig. 4c-Section A-A for Screw Fastened Edge Connections



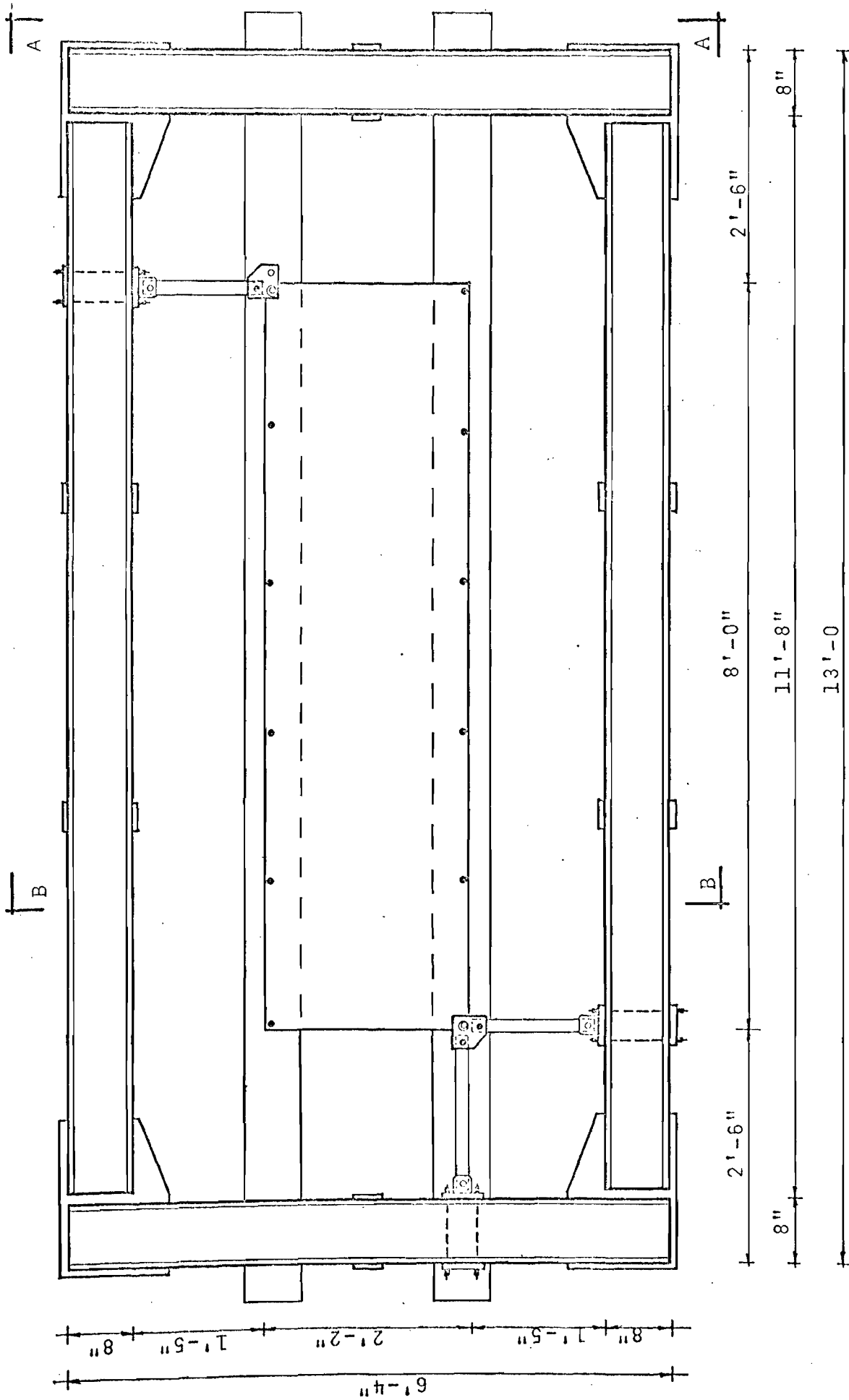
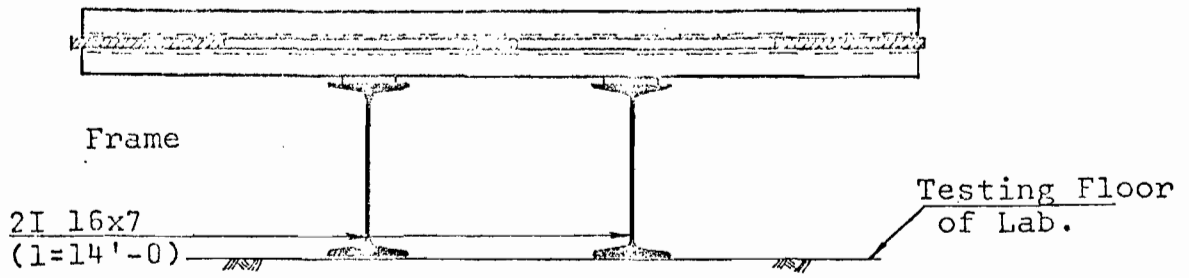
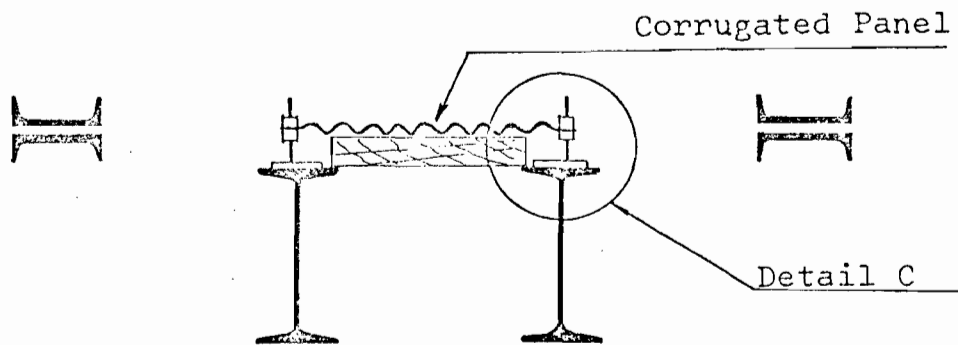

Fig. 6a - Panel Testing Frame - Plan View



Section A-A



Section B-B

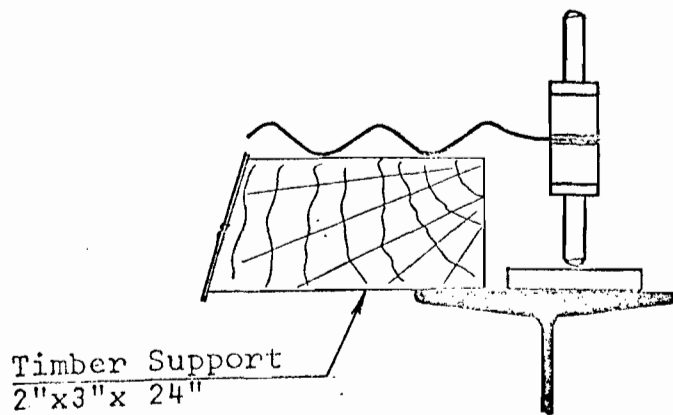

Detail C

Fig. 6b - Panel Testing Frame - Sections and Detail

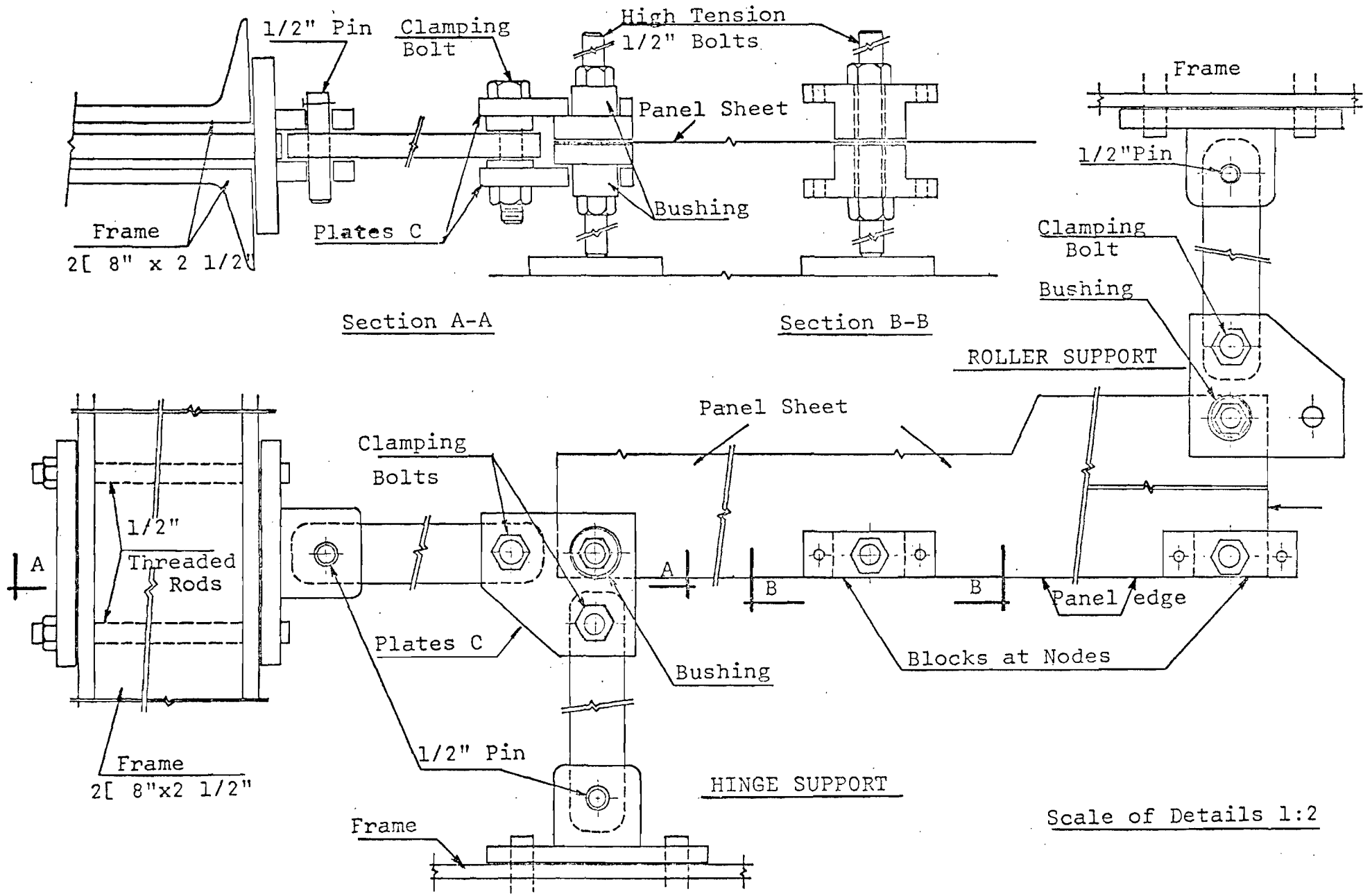
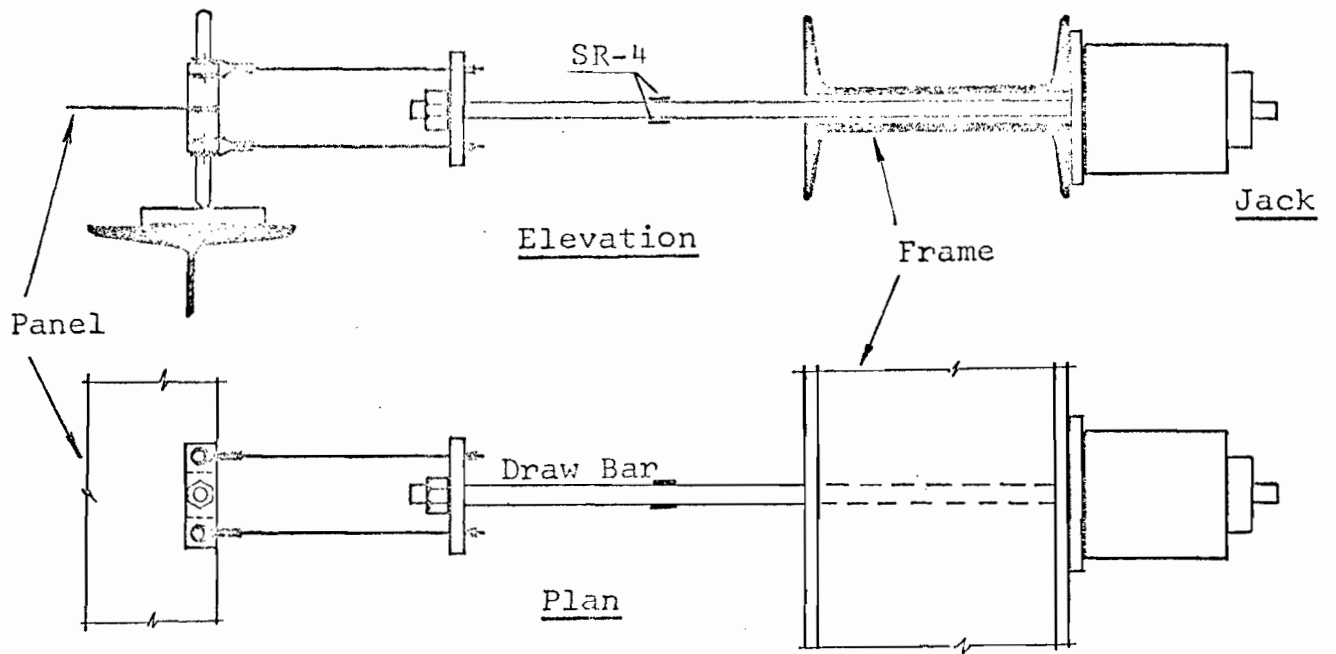
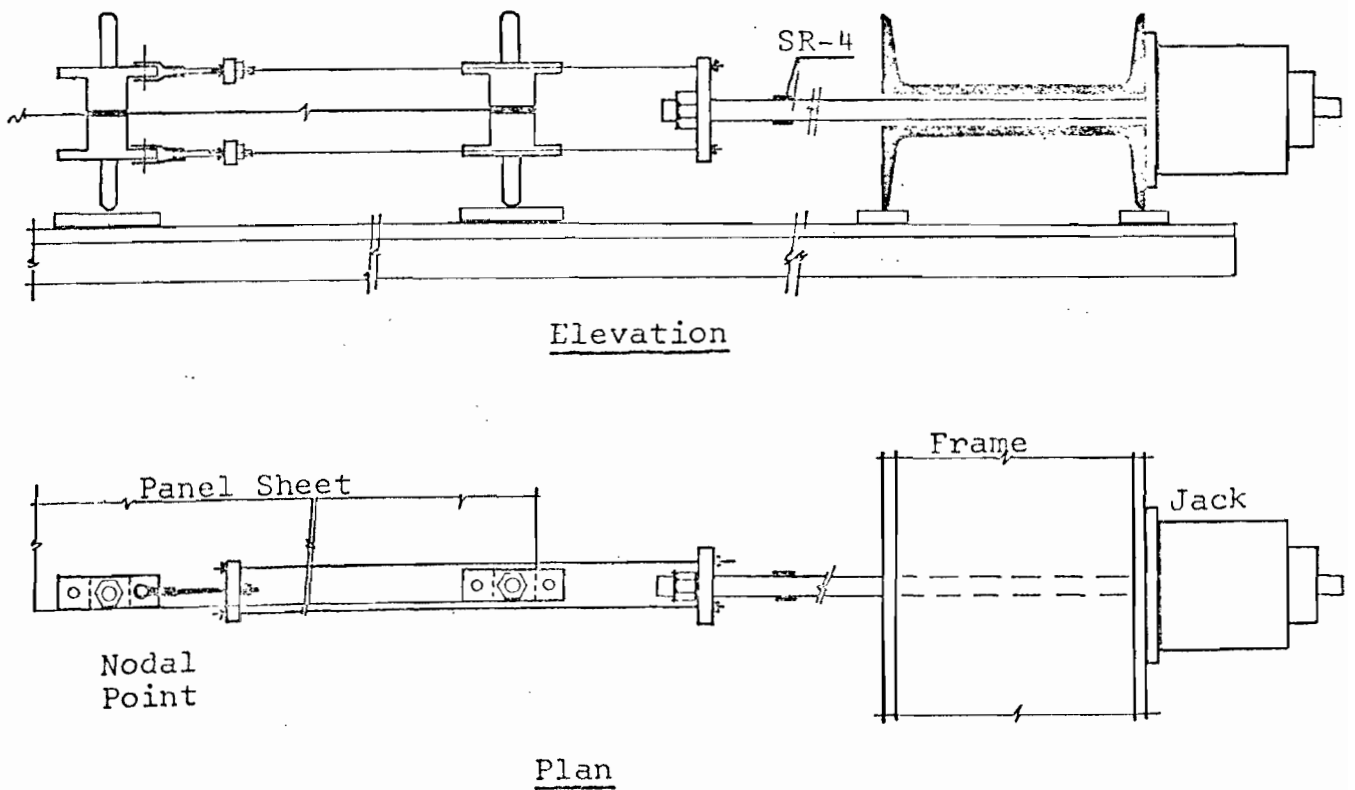

Fig. 6c - Panel Testing Frame, Details of Attachments and Panel Supports



a) Set-up for Transverse Loading



b) Set-up for Longitudinal Loading

Fig. 7 - Details of Loading Devices for Panel Testing

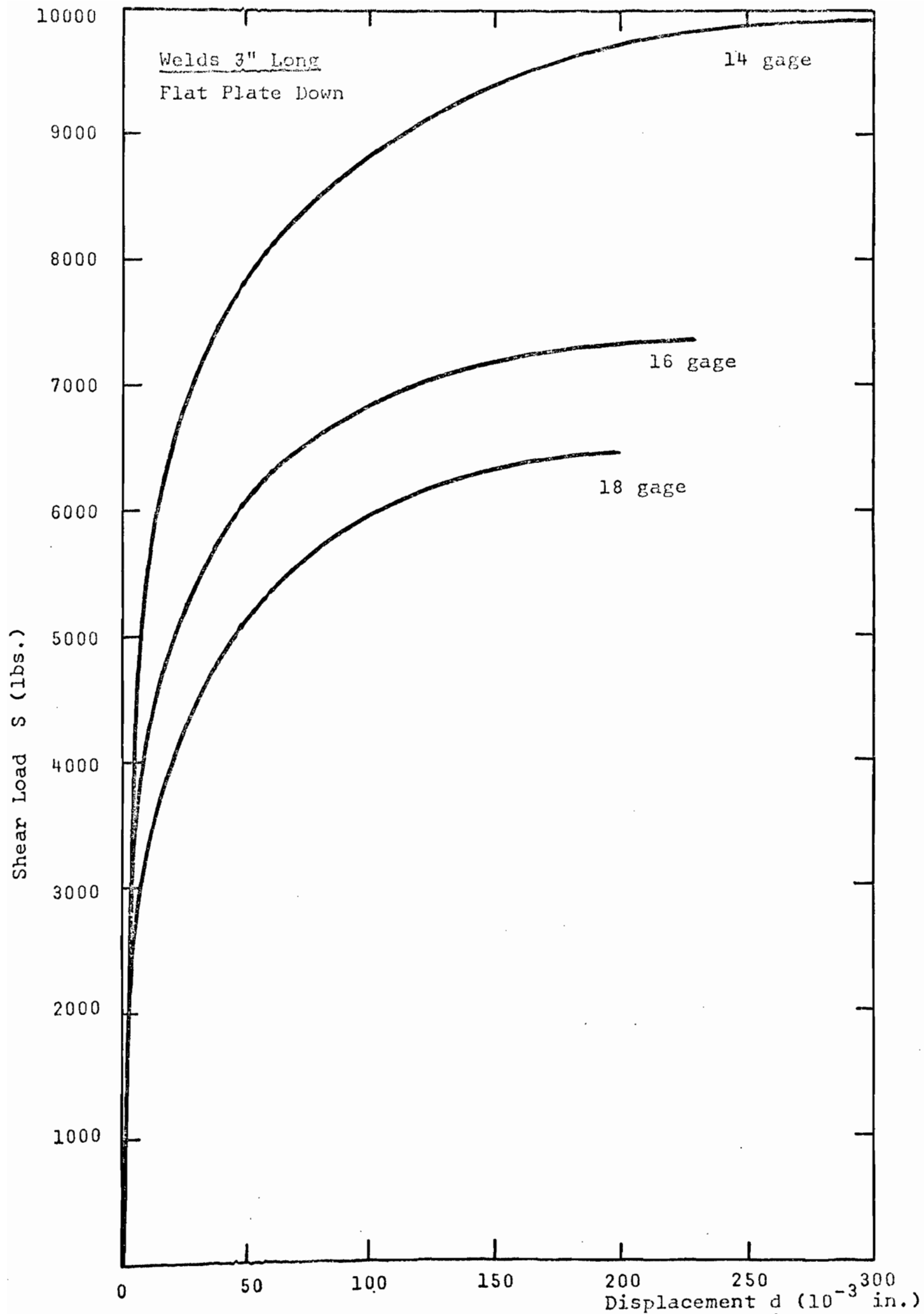

Fig. 8 ~ Load vs. Slip for Welded Sidelap Connections

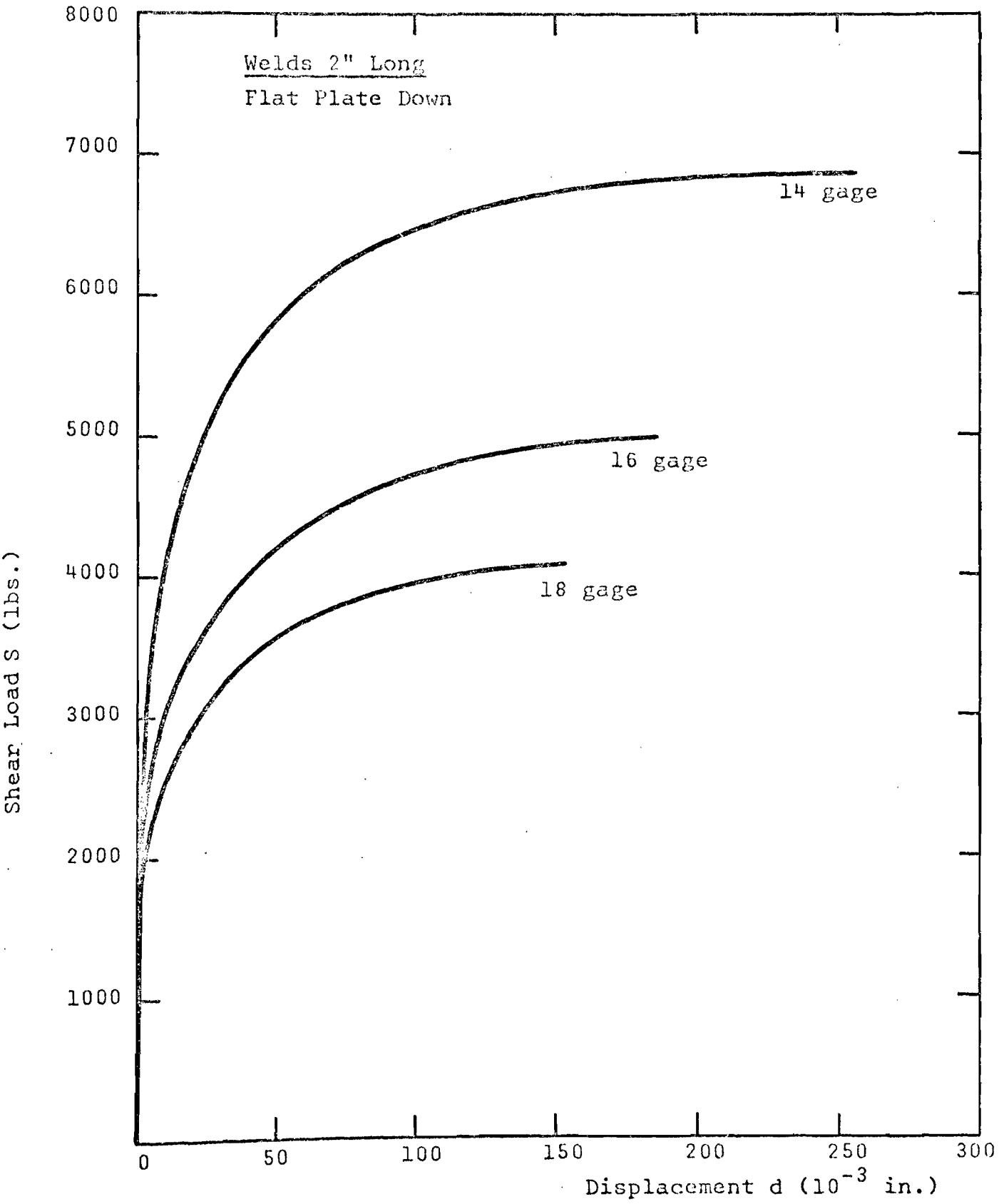

Fig. 9 - Load vs. Slip for Welded Sidelap Connections

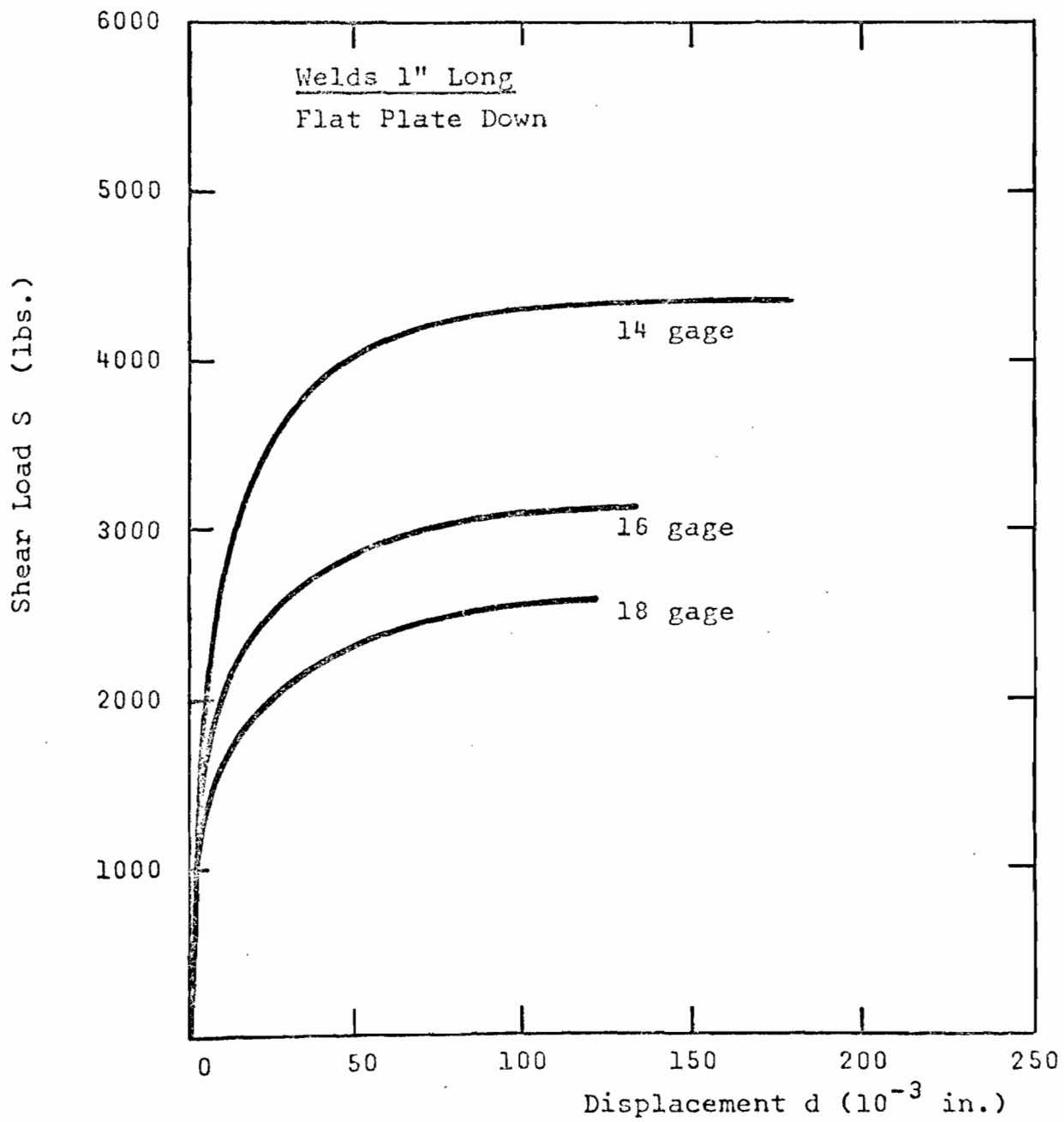

Fig. 10-Load vs. Slip for Welded Sidelap Connections

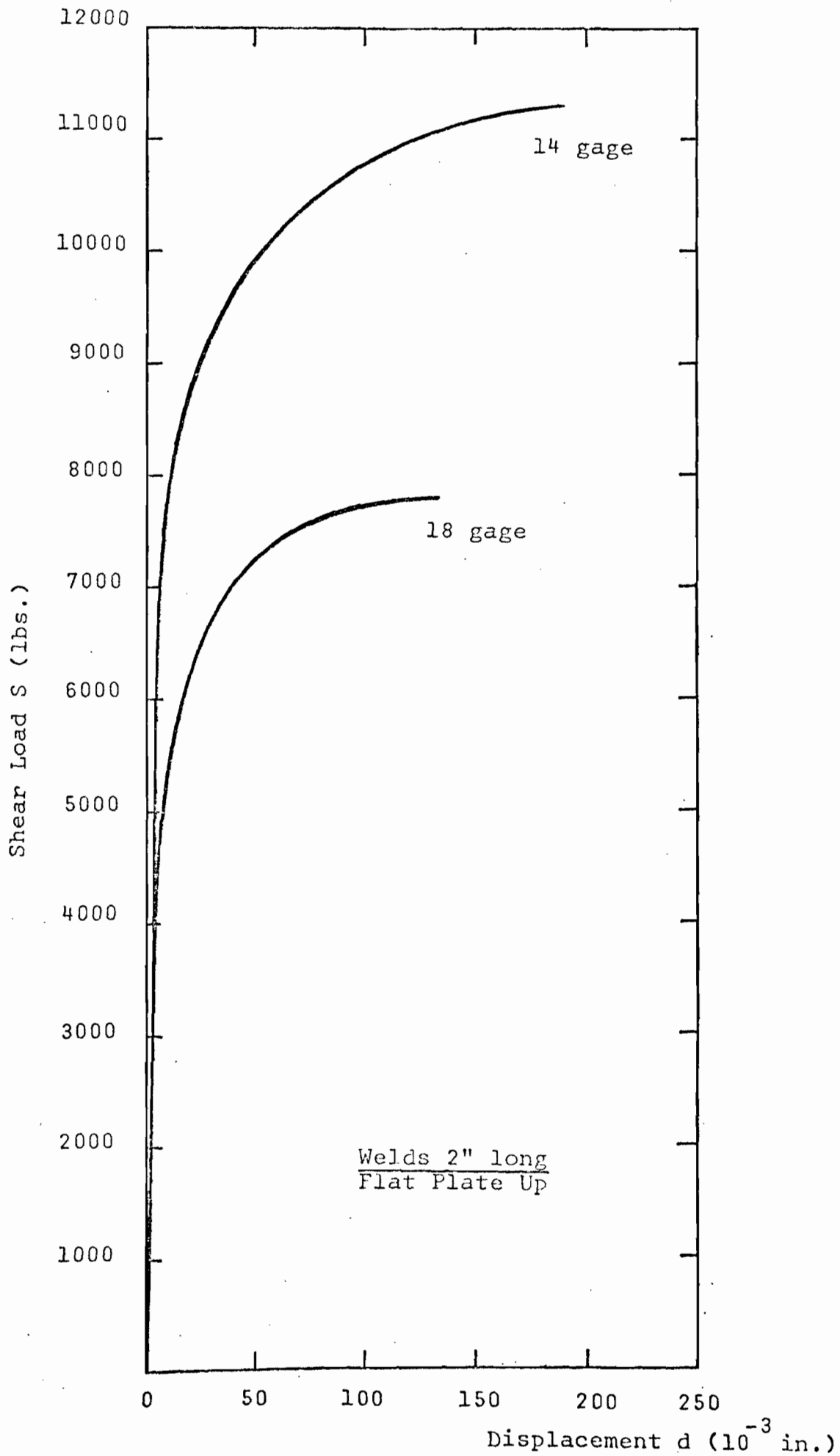

Fig. 11 - Load vs. Slip for Welded Sidelap Connections

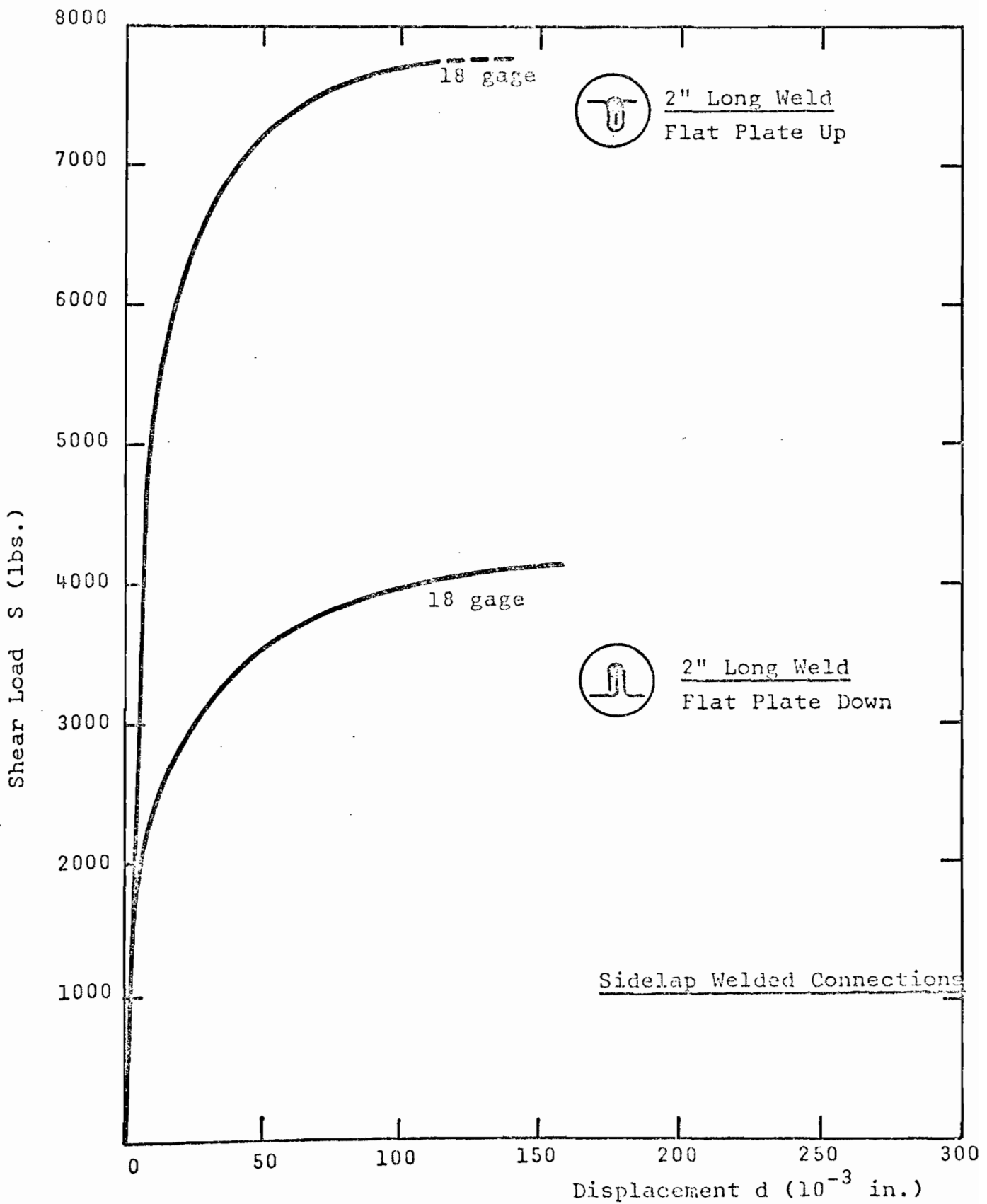

Fig. 13-Comparison between Welded Sidelaps,
Flat Up and Flat Down

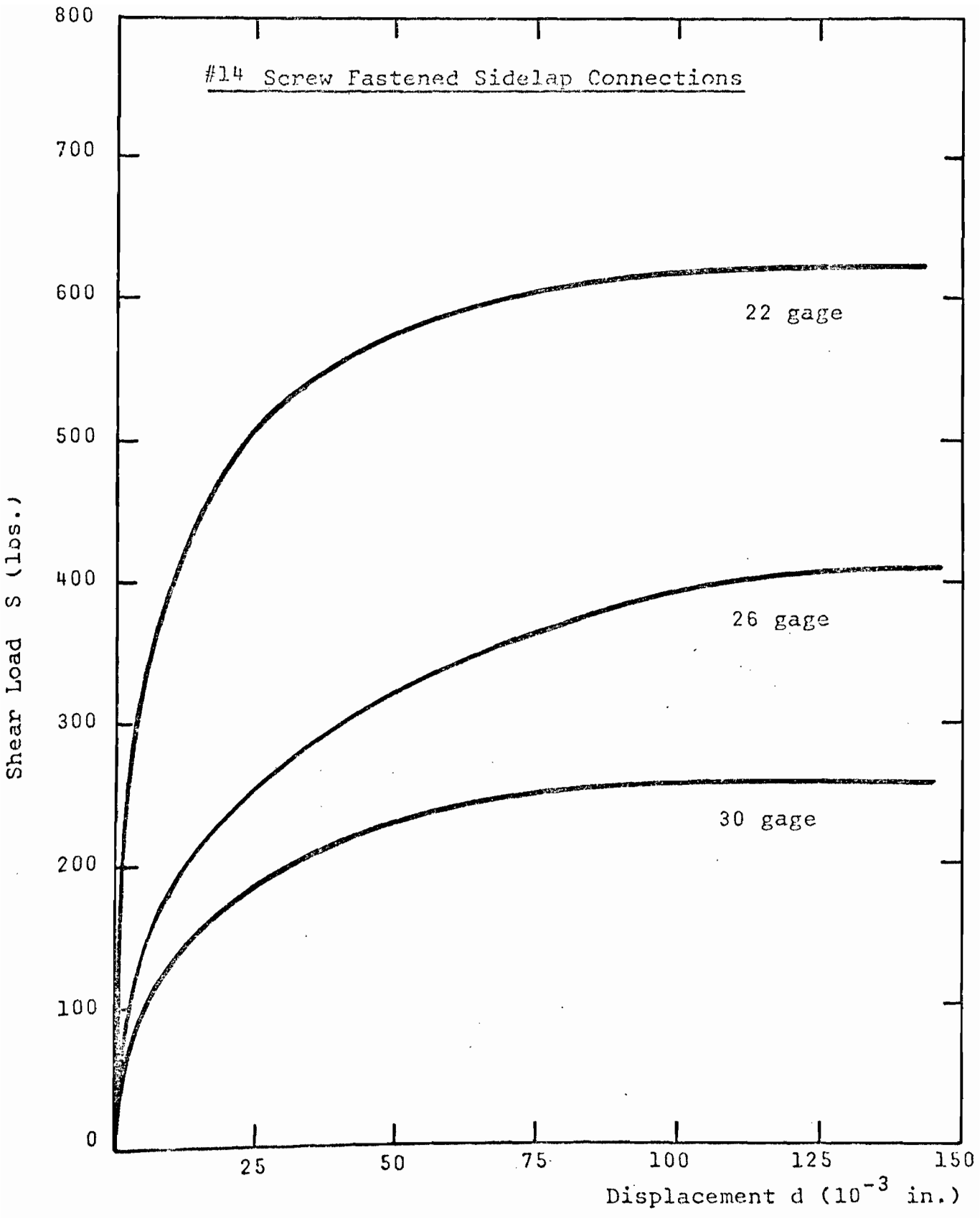

Fig. 14- Load vs. Slip for #14 Screw Fastened Sidelap Connections

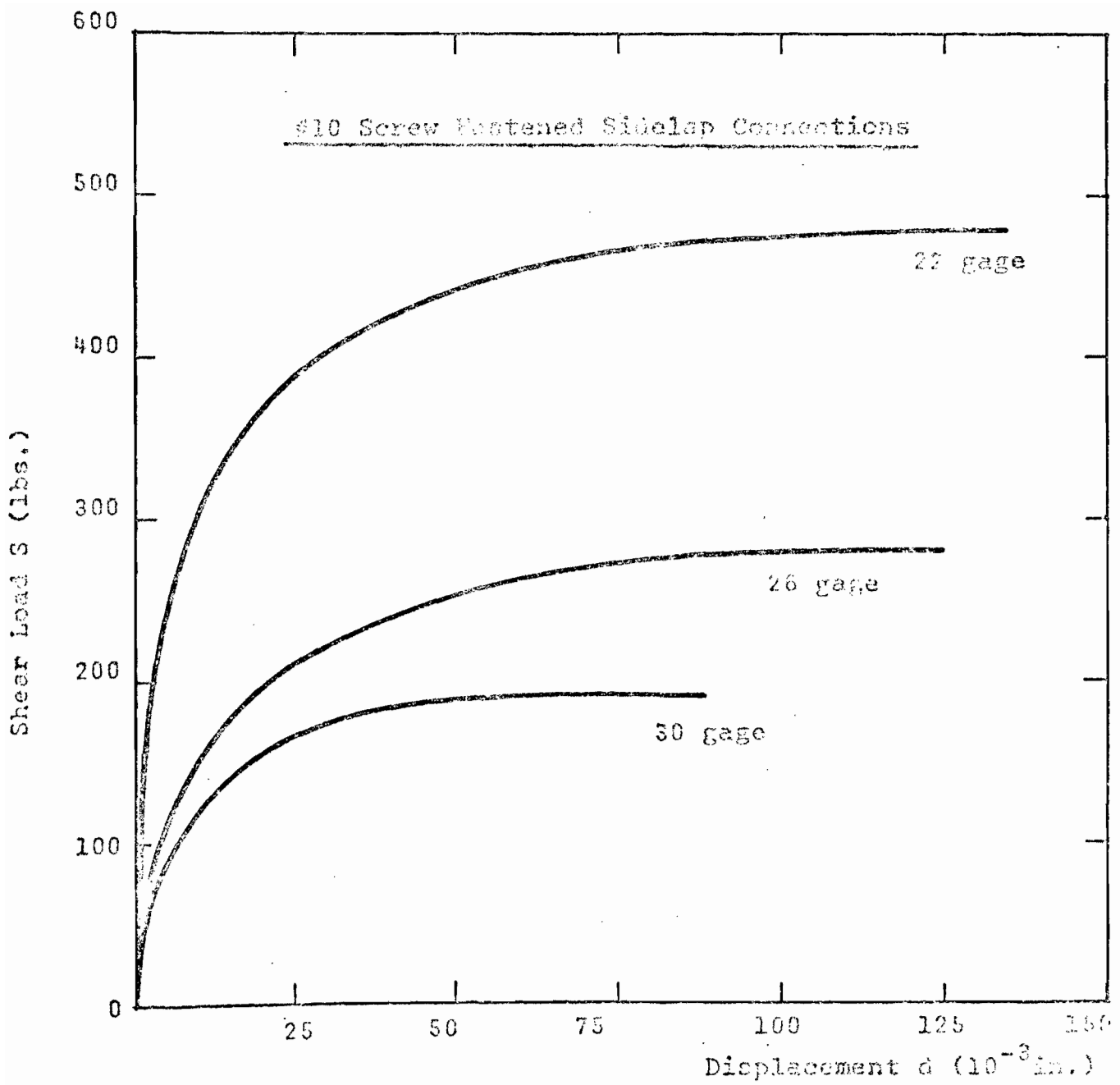

Fig. 15 - Load vs. Slip for #10 Screw Fastened Sidelap Connections

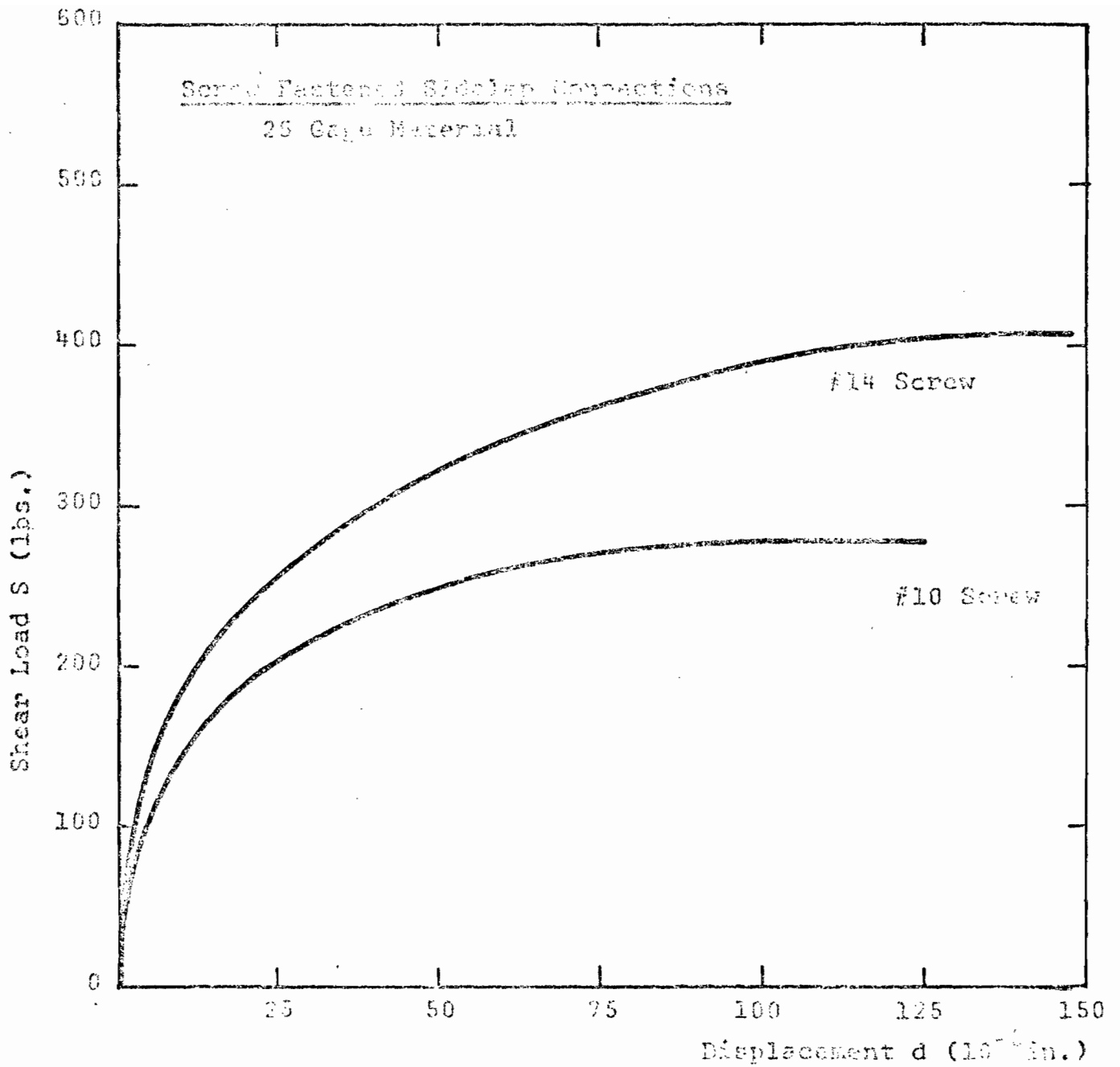

Fig. 16 - Comparison between #14 and #10 Screw Fastened Sidelap Connections

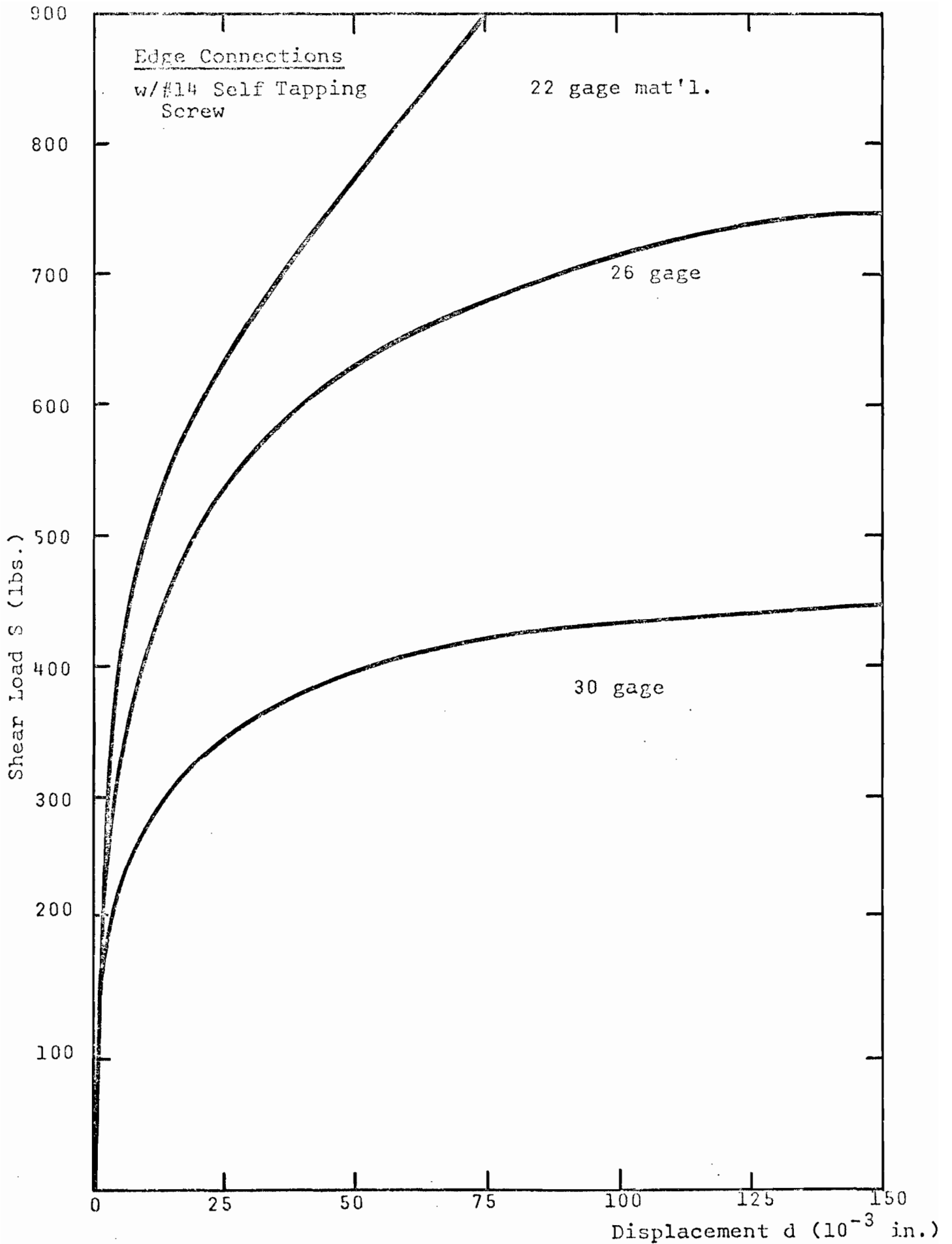

Fig. 17- Load vs. Slip for #14 Screw Fastened Edge Connections

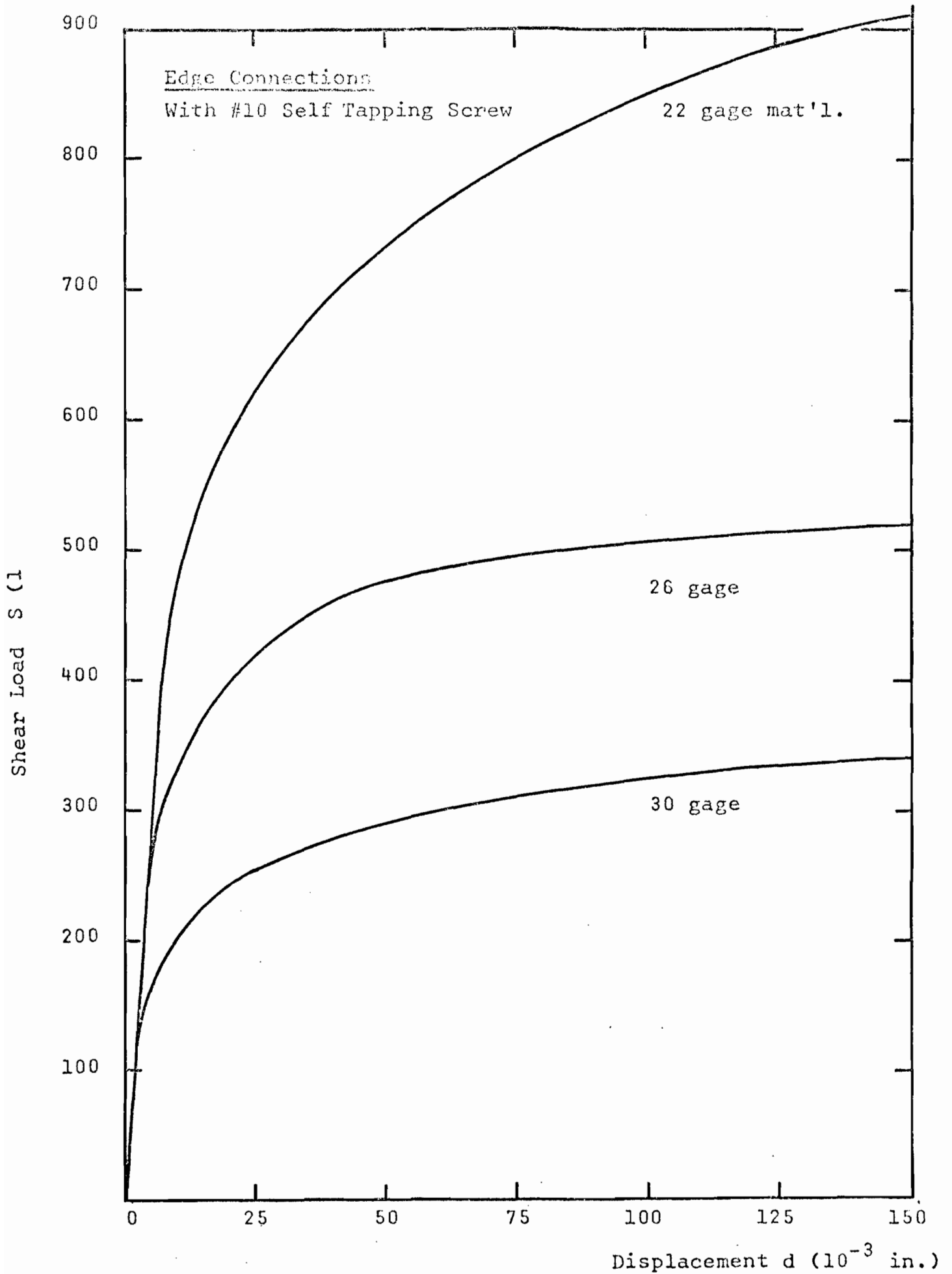

Fig. 18-Load vs. Slip for #10 Screw Fastened Edge Connections

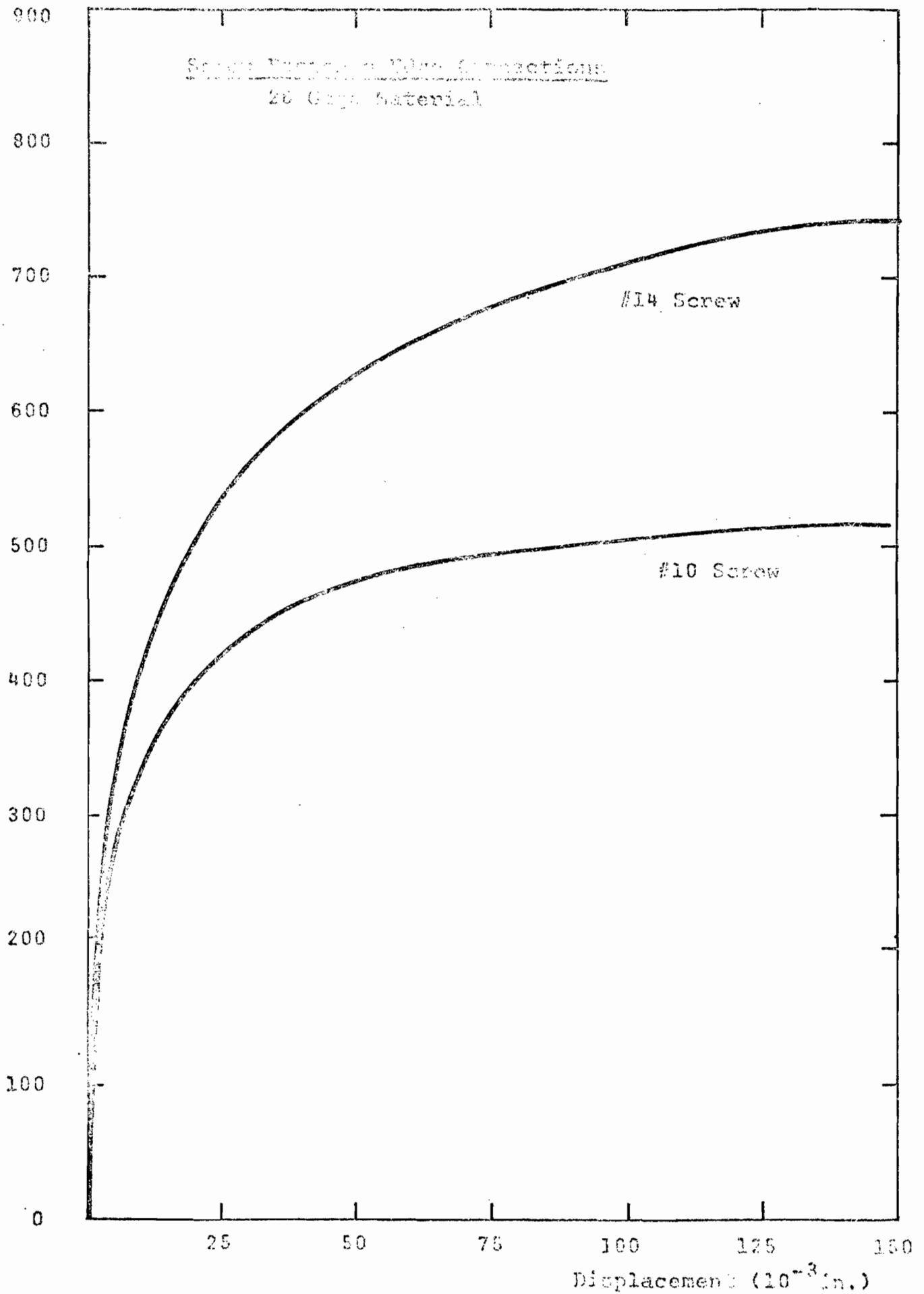

Fig. 19 - Comparison between #14 and #10 Screw Fastened Edge Connections.

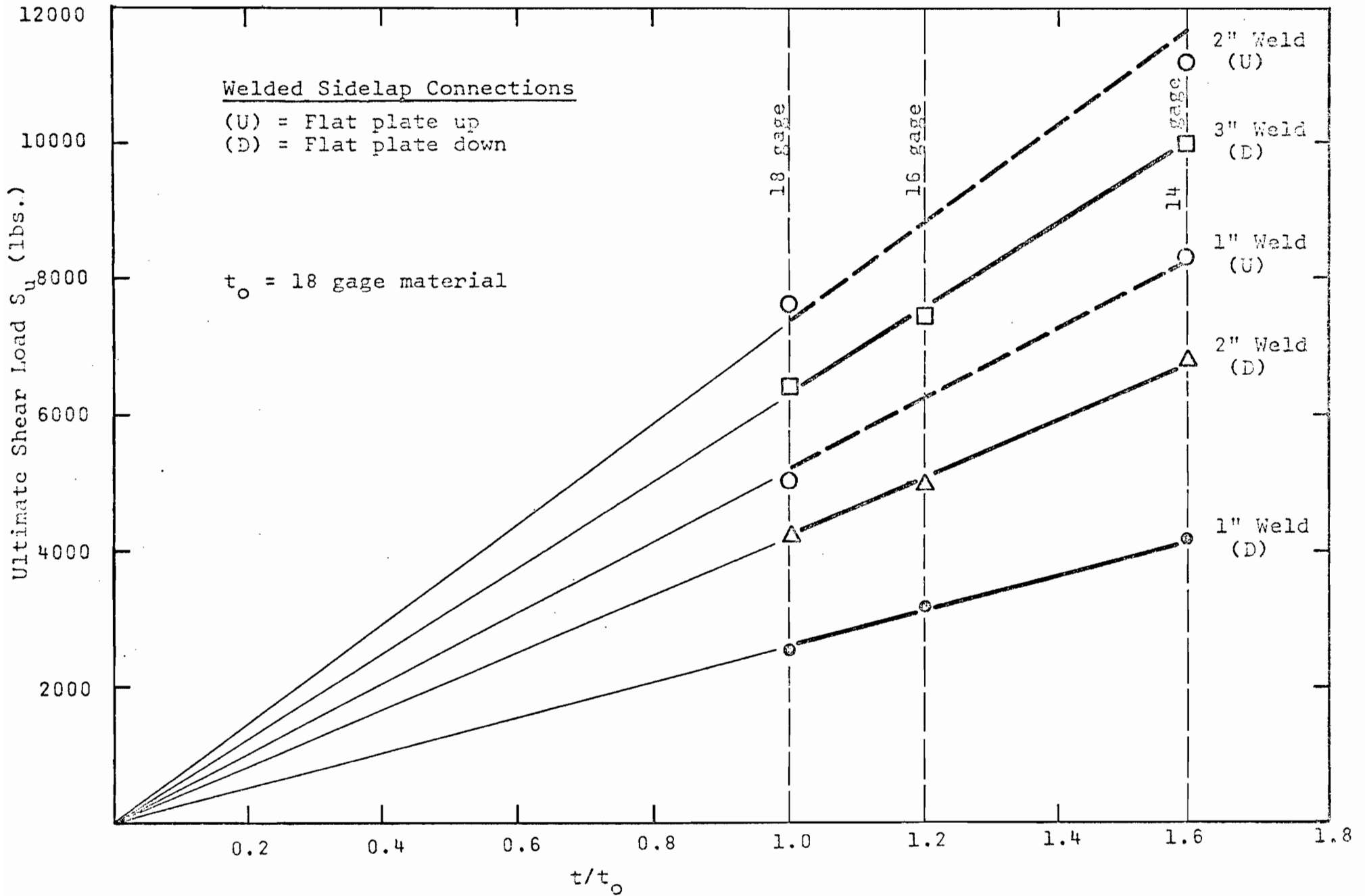

Fig. 20-Variation of Ultimate Shear Capacity with Material Thickness

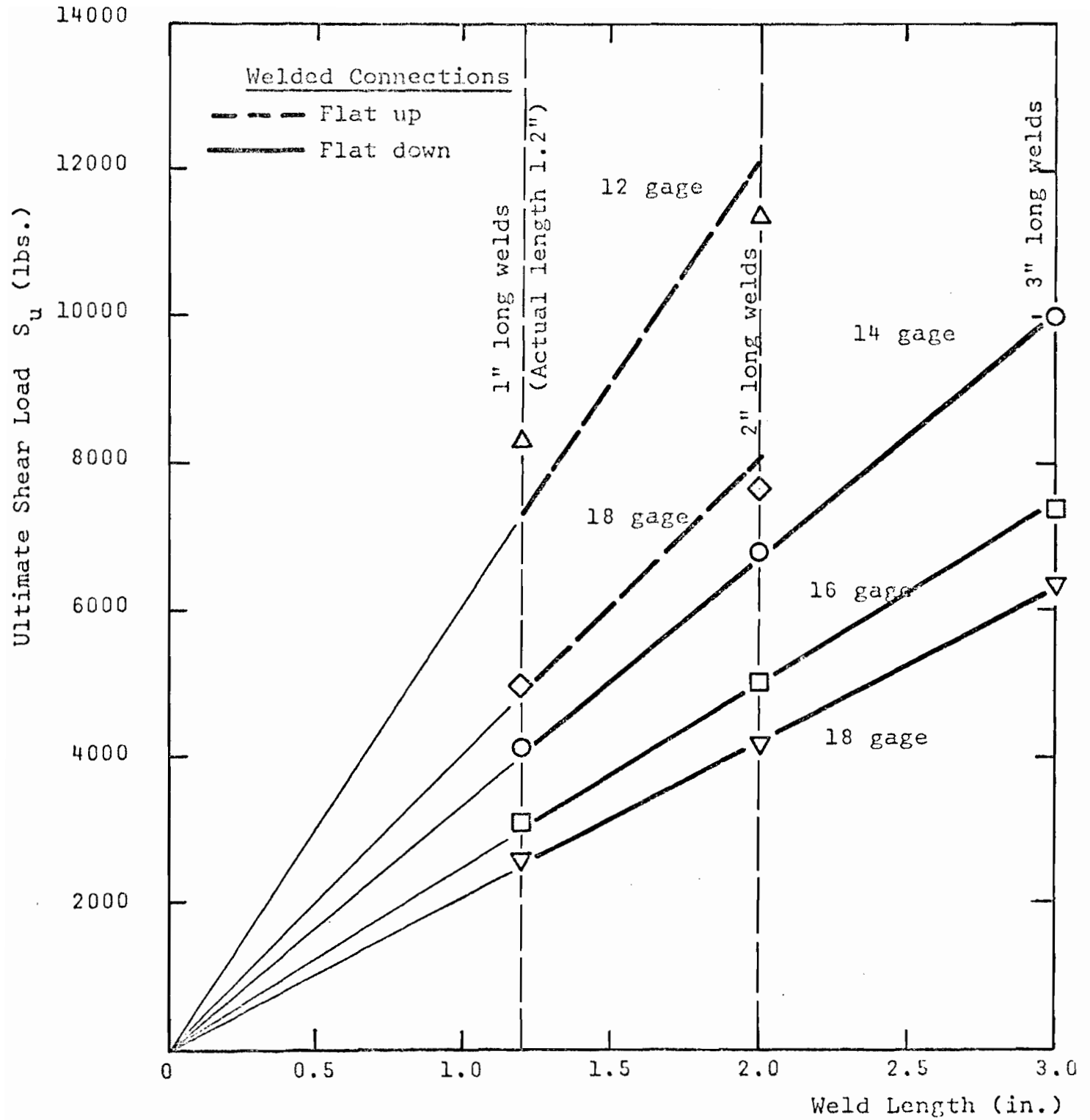

Fig. 21- Variation of Ultimate Shear Capacity with Weld Length

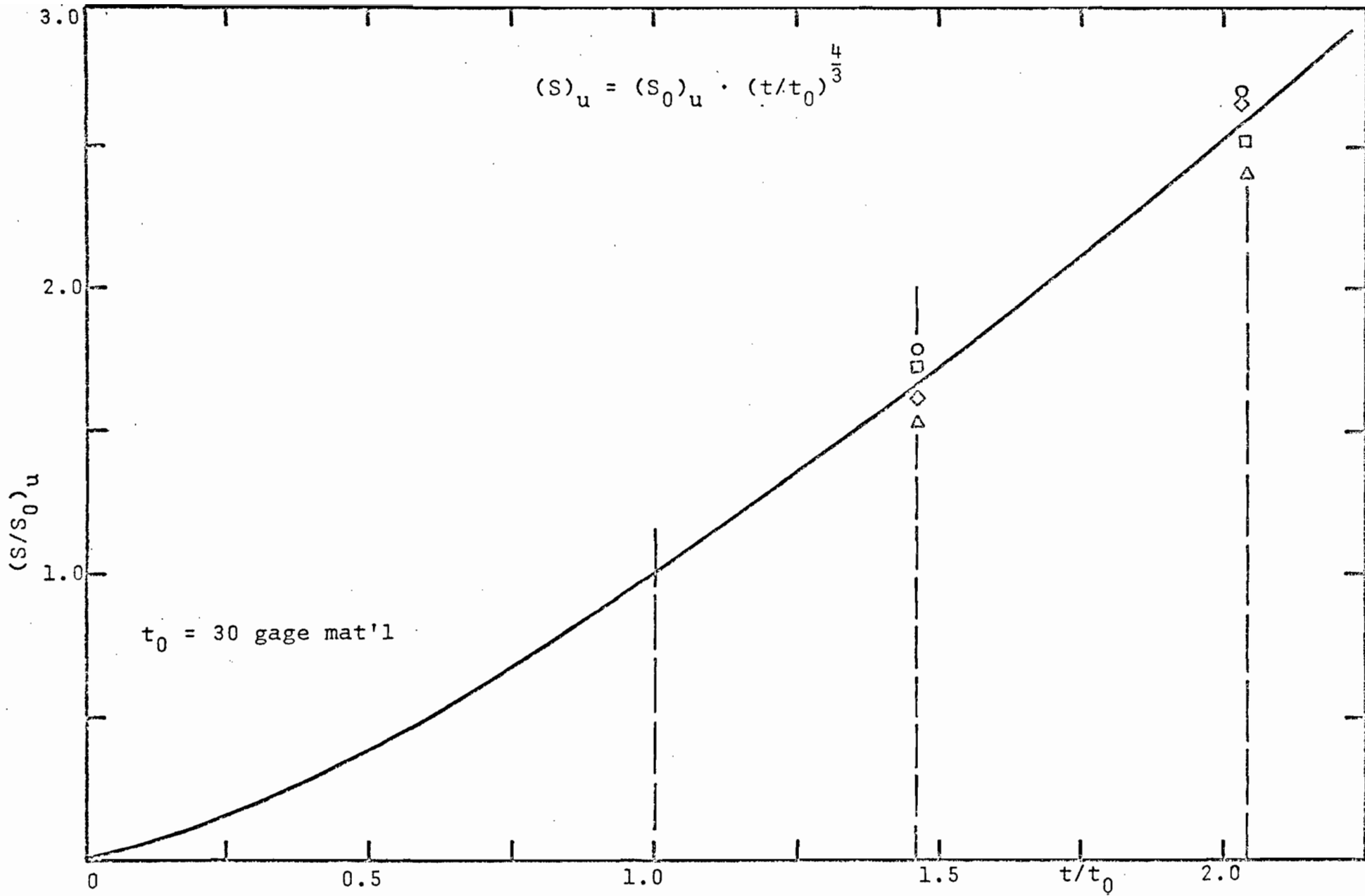

Fig. 22 - Variation of Ultimate Shear Capacity with Material Thickness for Screw Fastened Connections

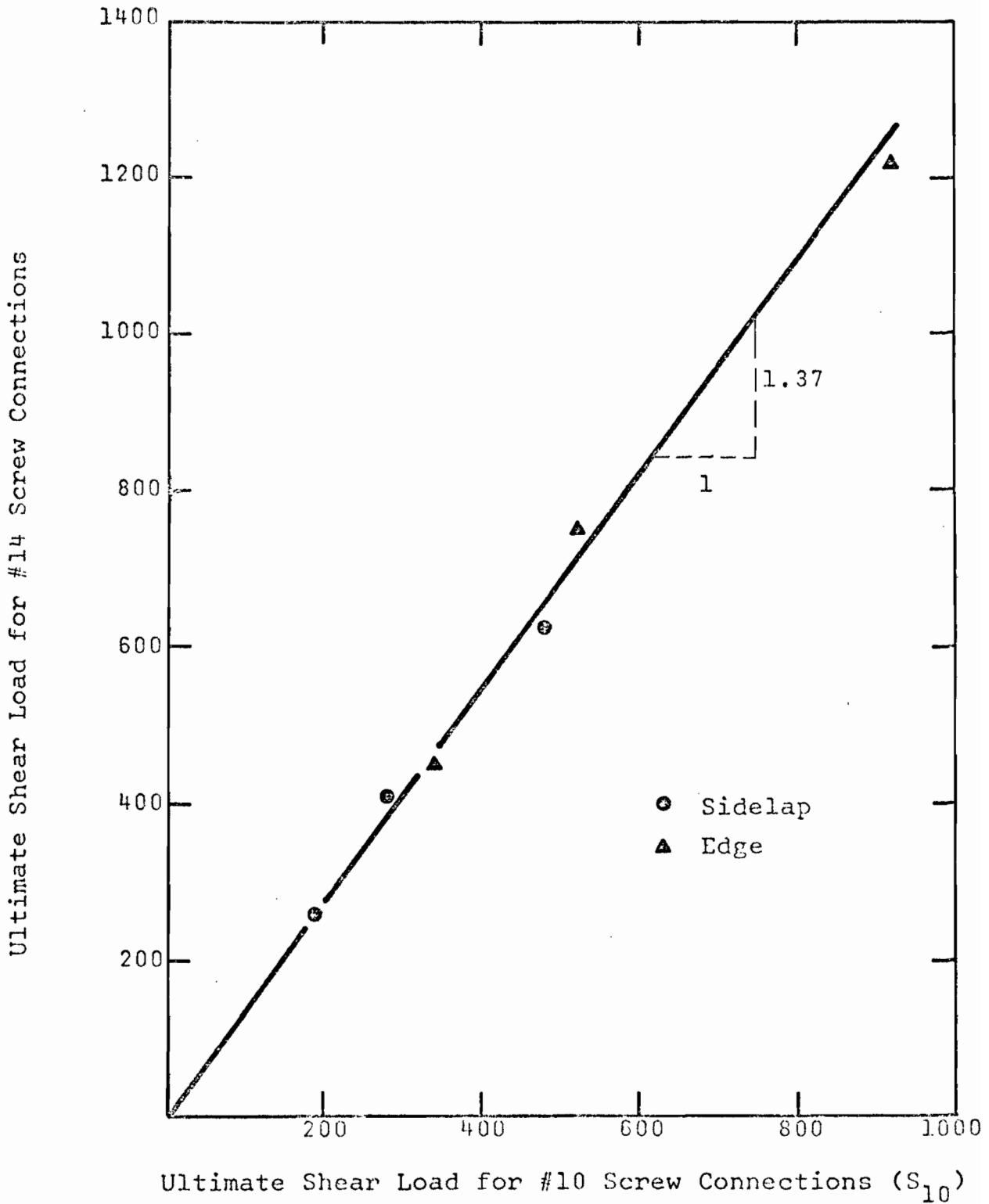

Fig. 23- Comparison between #14 and #10 Screws, for Ultimate Shear Capacity of Screw Fastened Connections

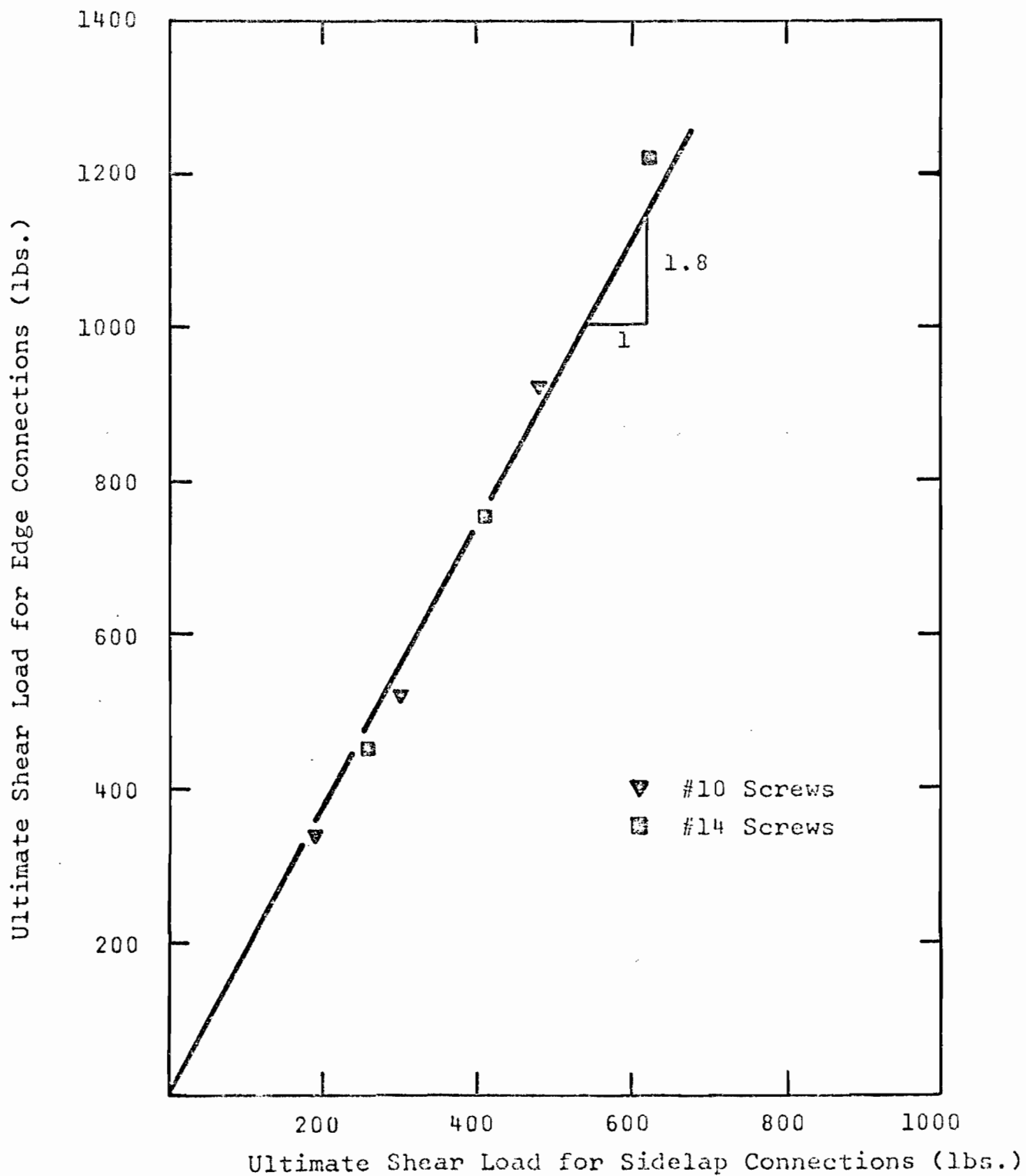
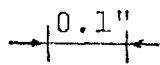
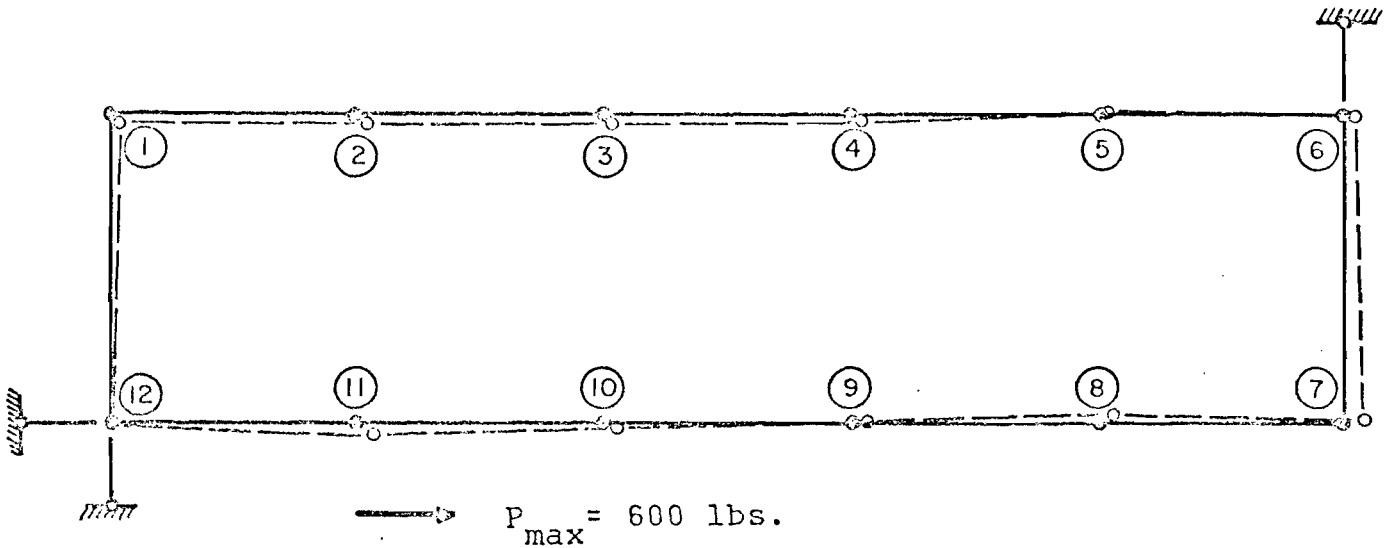

Fig. 24-Comparison between Edge and Sidelap Screw Fastened Connections



Scale for Displacements



a) Displacements due to load at node 11

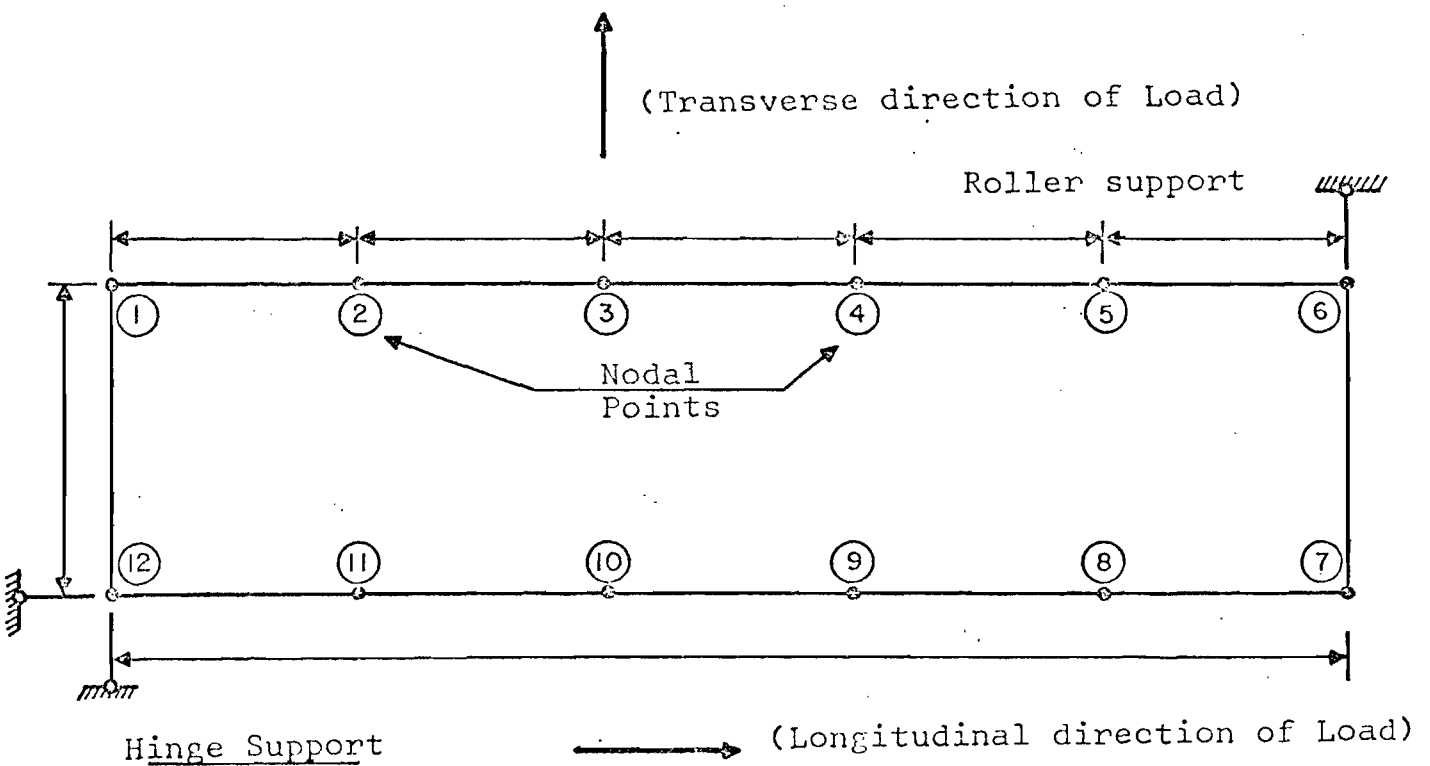

_____ Panel Edge before load application

----- Panel Edge with load application

• Nodal Point before deformation

○ Nodal Point after deformation

Fig. 25a - Deformations of Corrugated Panel under In-plane Longitudinal Load.

0.1"

Scale for Displacements

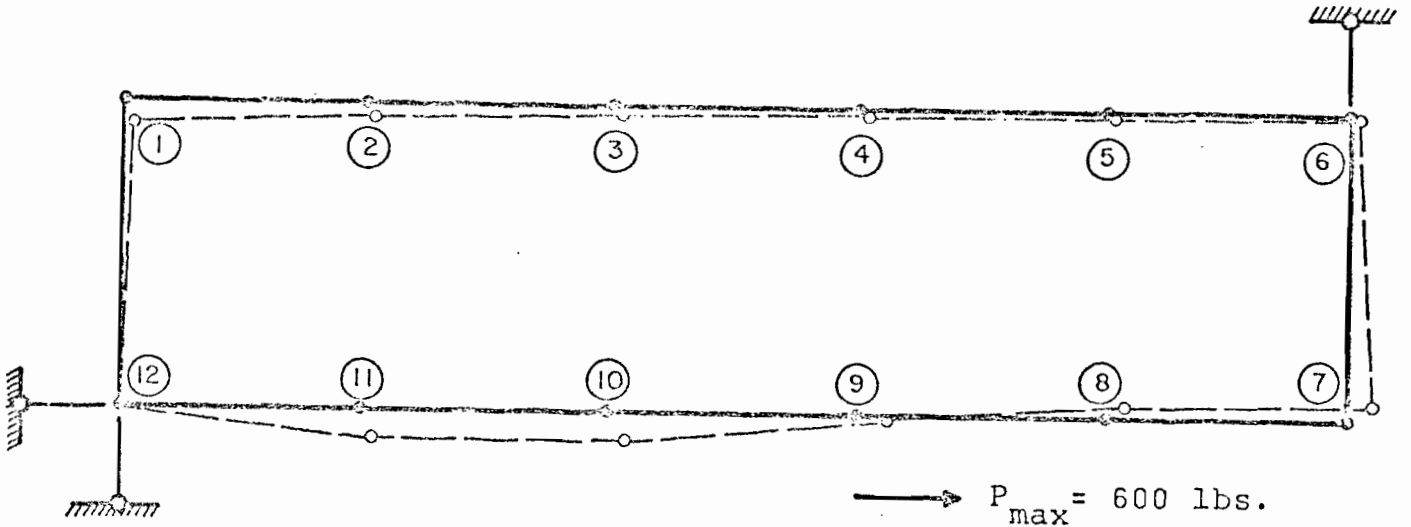

a) Displacements due to Load at node 9

0.1"

Scale for Displacements

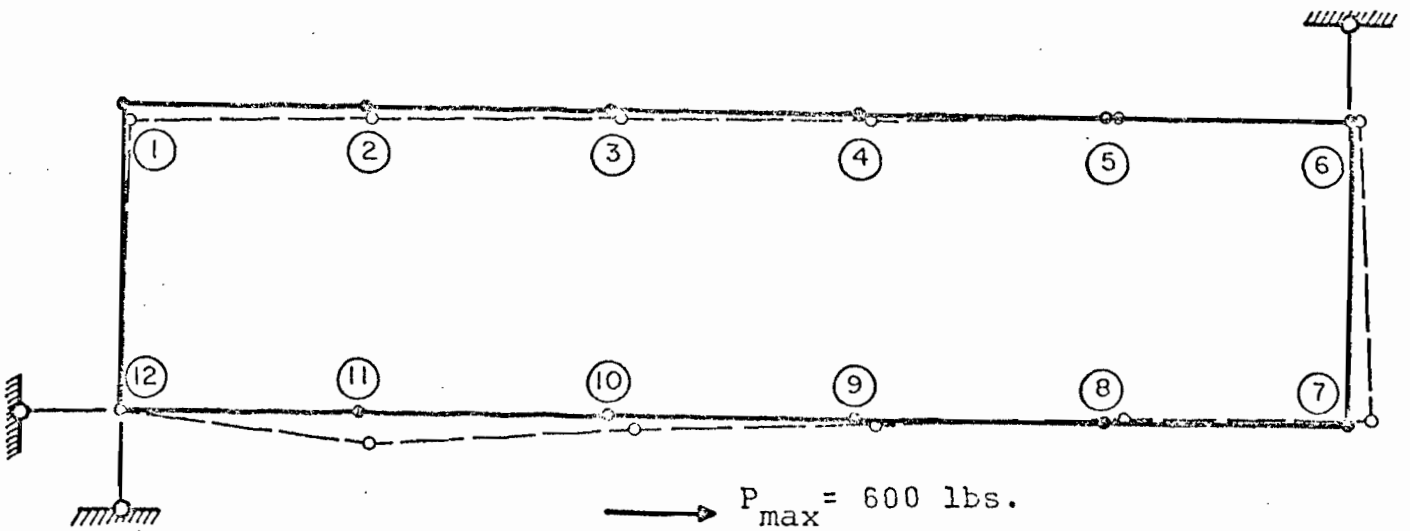

b) Displacements due to Load at node 10

Fig. 25b - Deformation of Corrugated Panel under In-plane Longitudinal Load

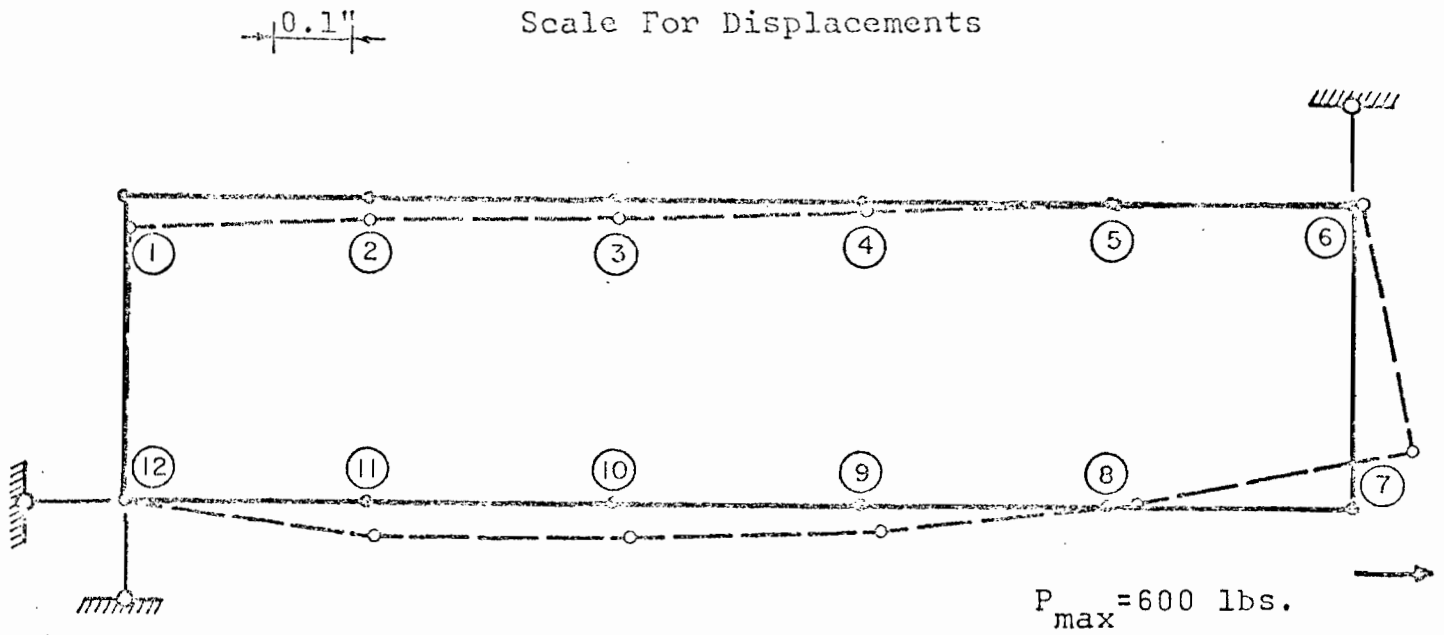

a) Displacements due to load at node 7

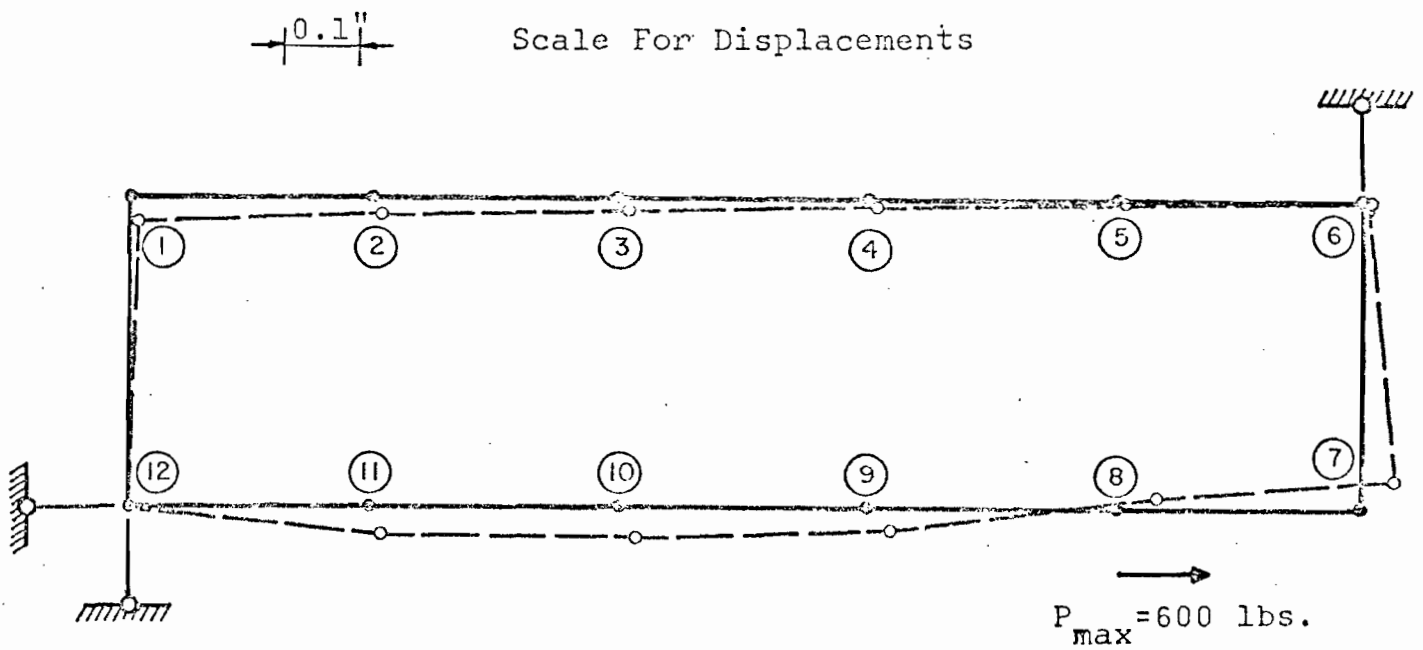

b) Displacements due to load at node 8

Fig. 25c - Deformation of Corrugated Panel under In-plane Longitudinal Load

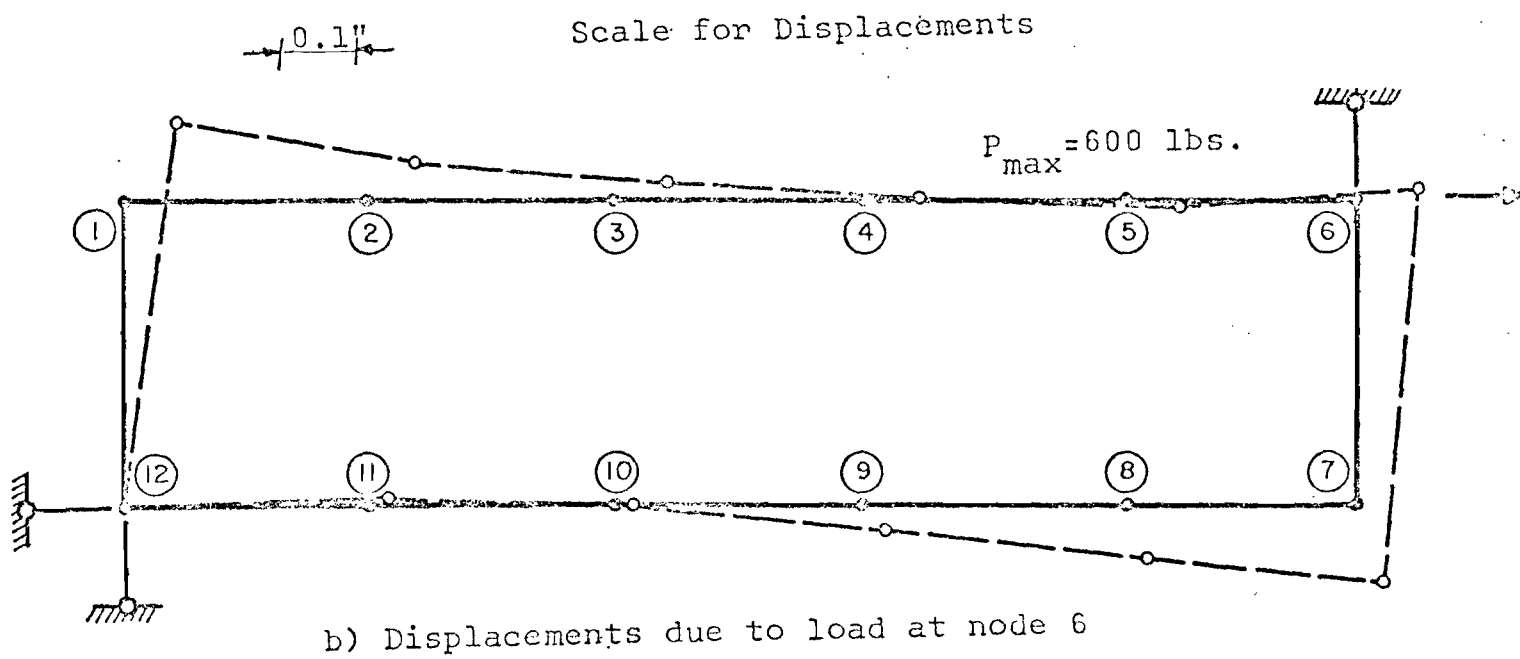
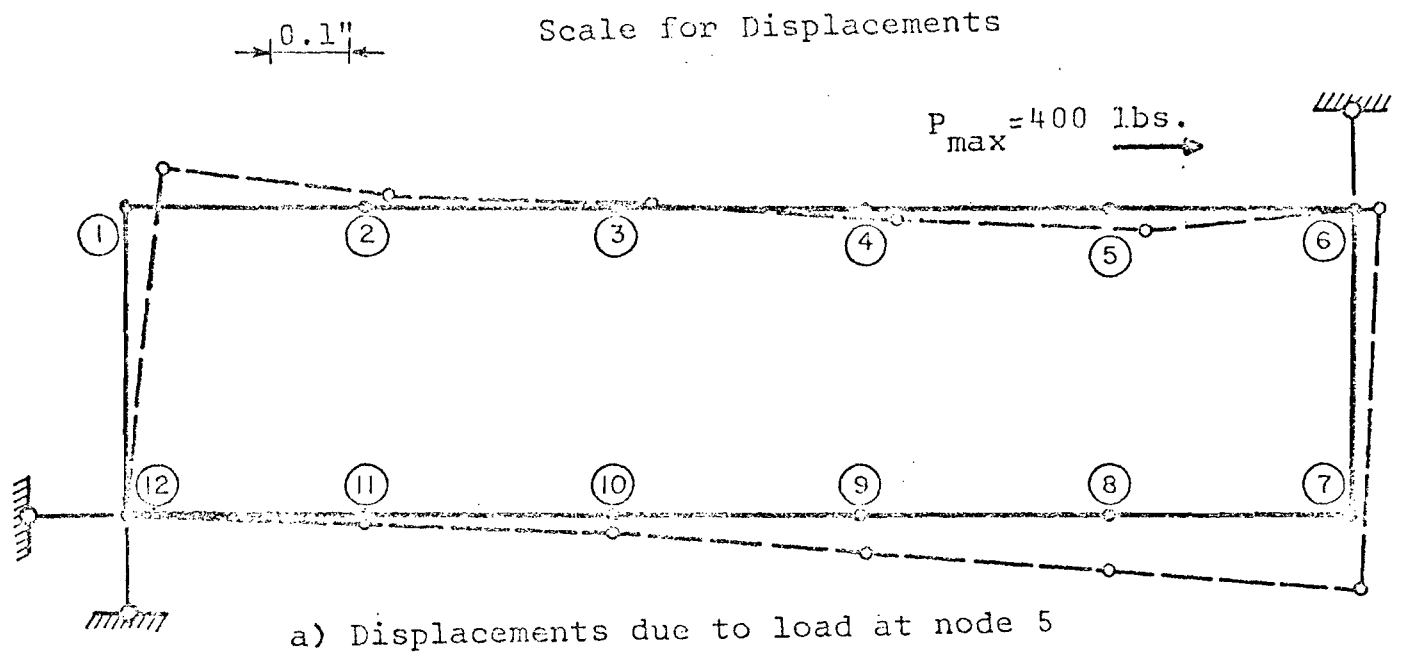

Fig. 25d - Deformation of Corrugated Panel under In-plane Longitudinal Load

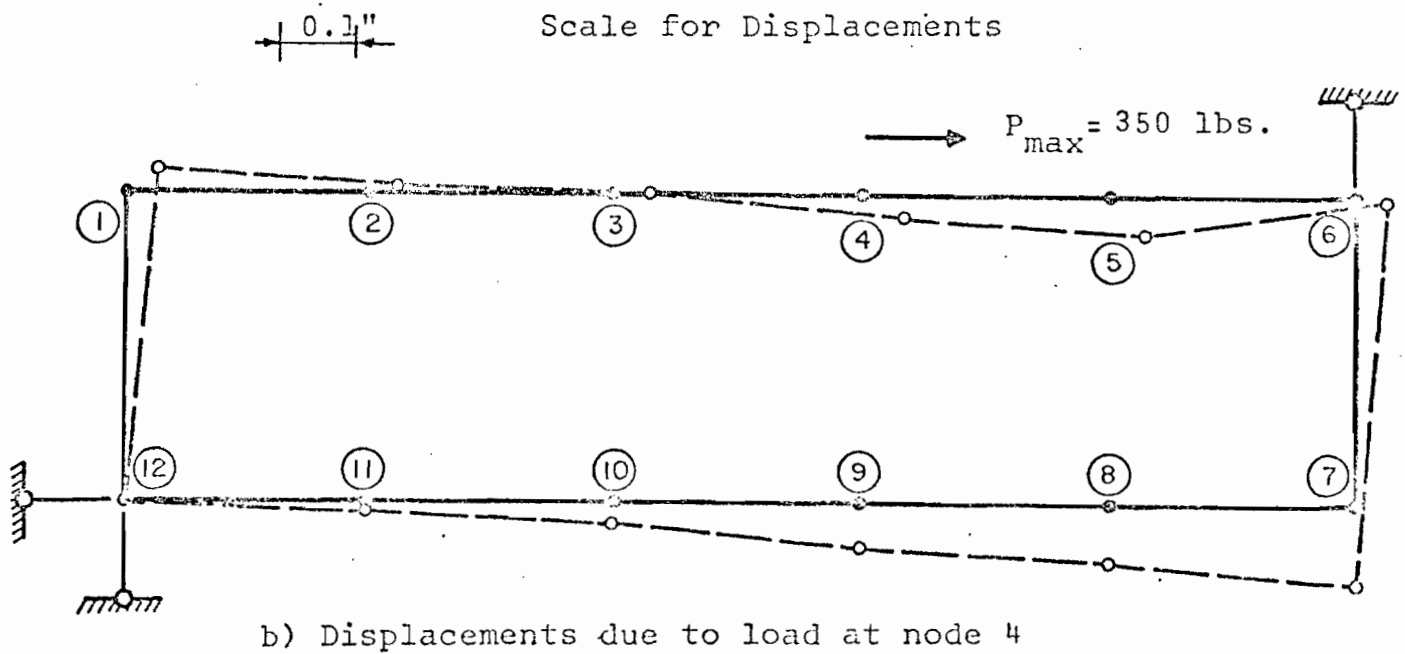
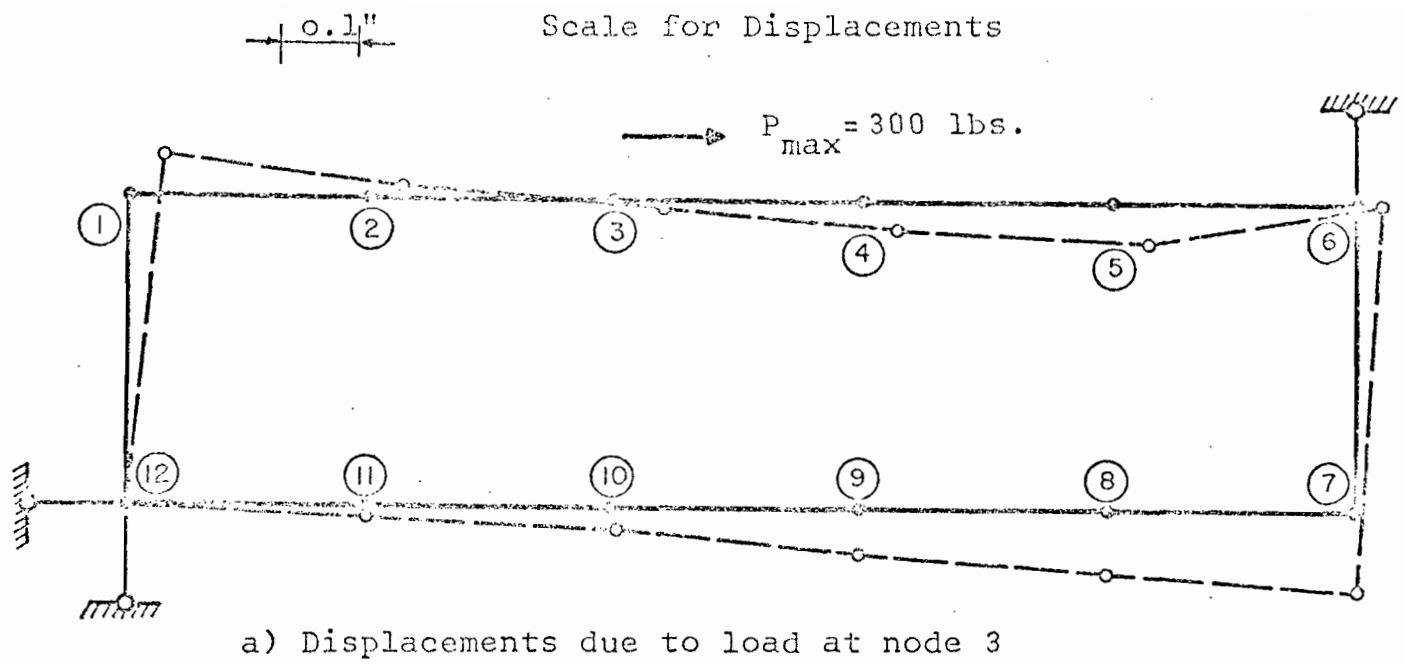

Fig. 25e - Deformation of Corrugated Panel under In-plane Longitudinal Load

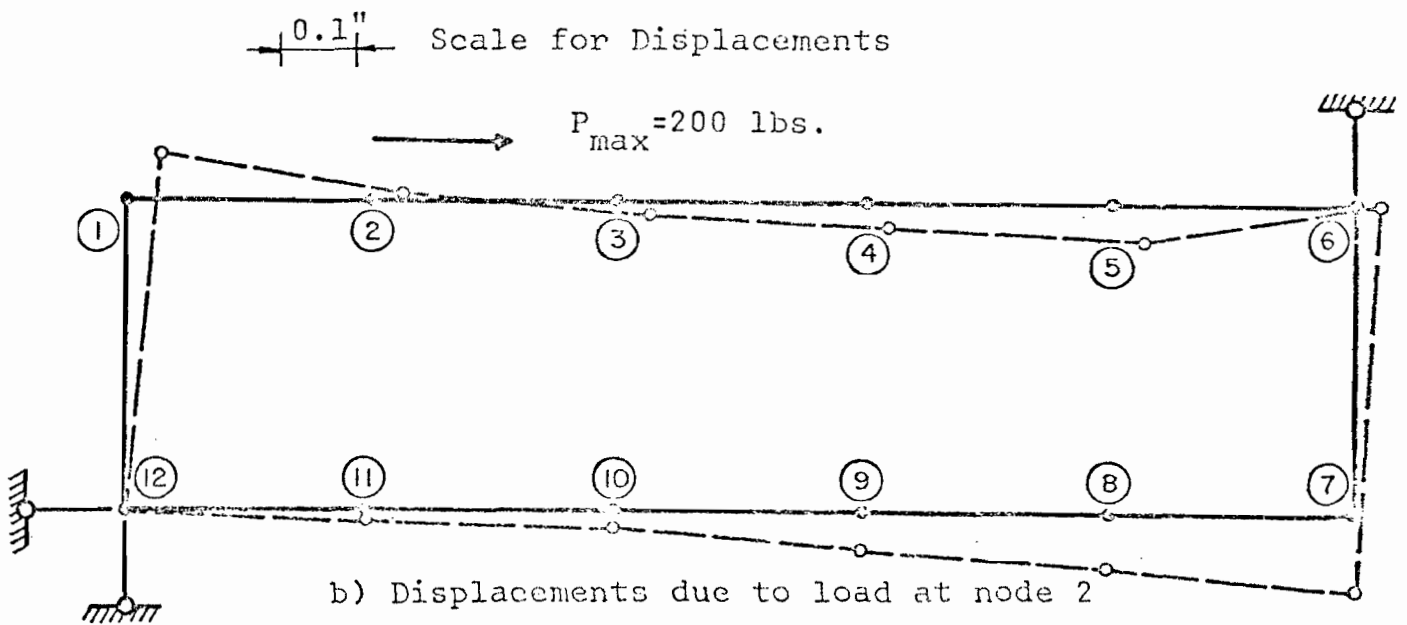
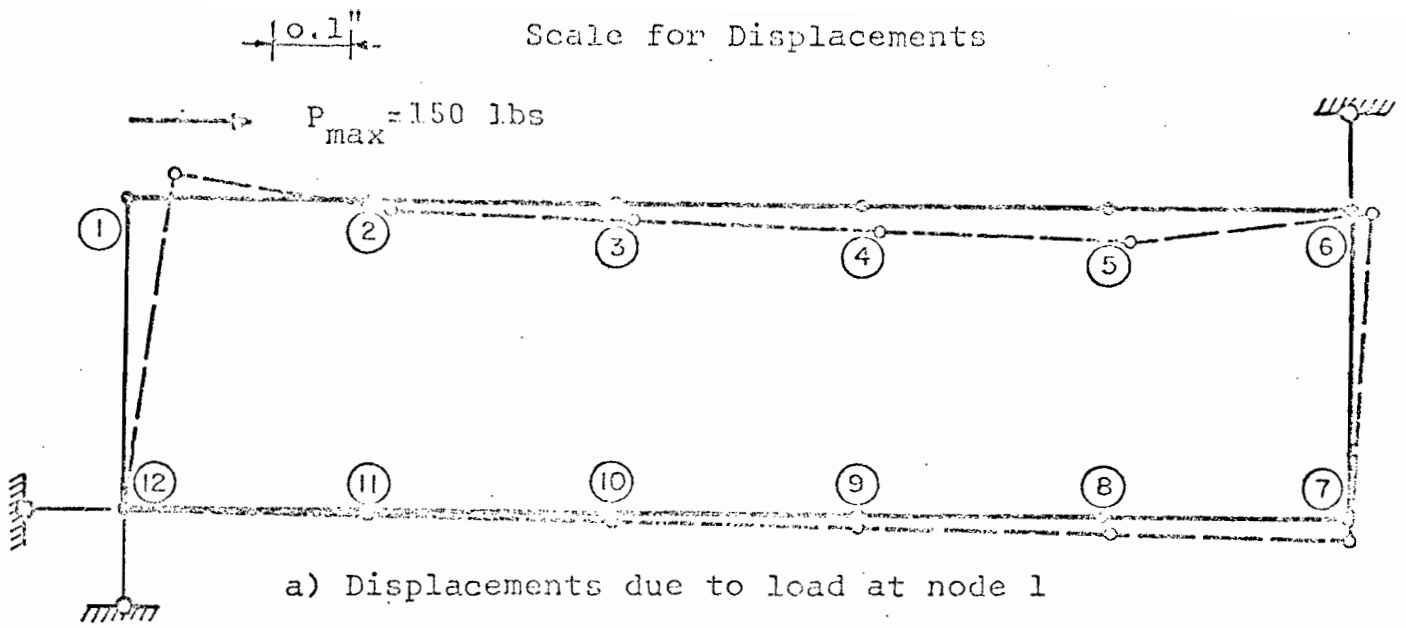

Fig. 25f - Deformation of Corrugated Panel under In-plane Longitudinal Load

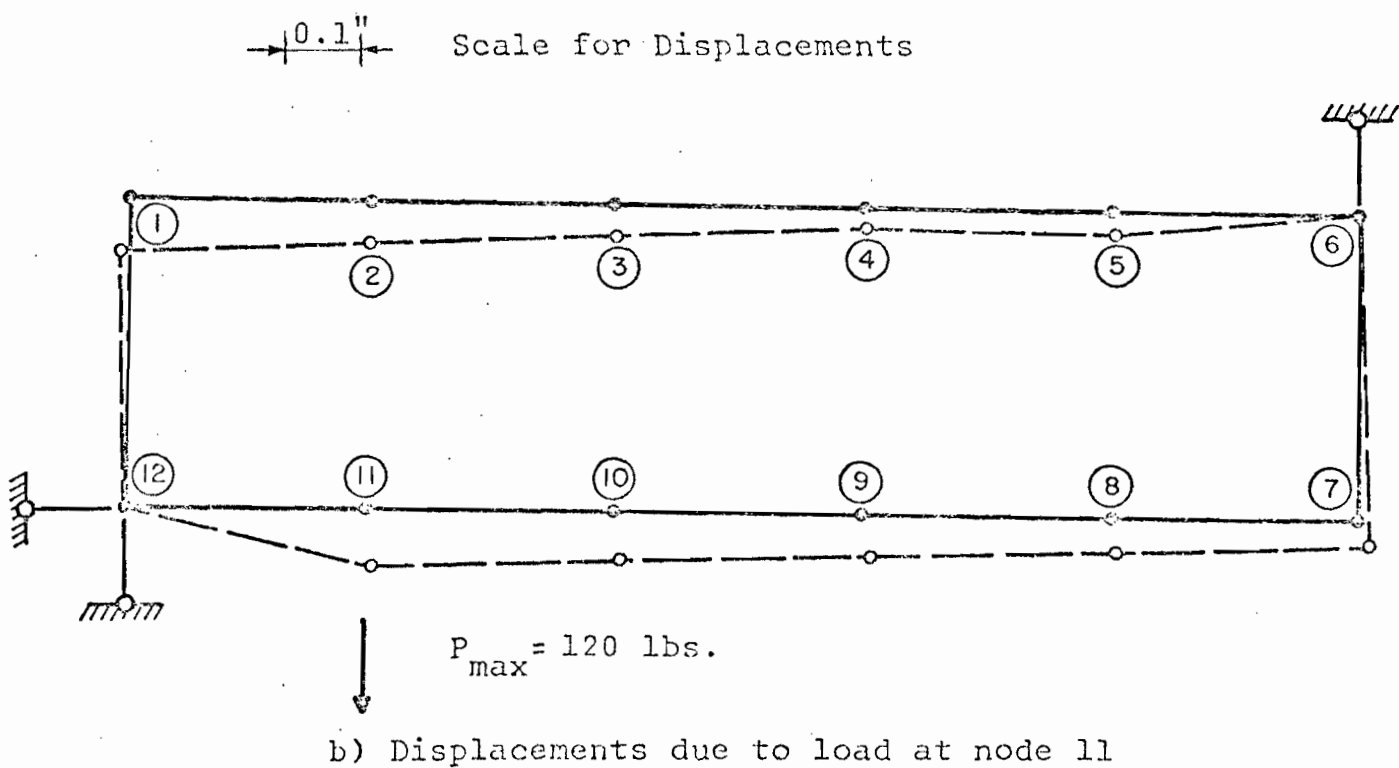
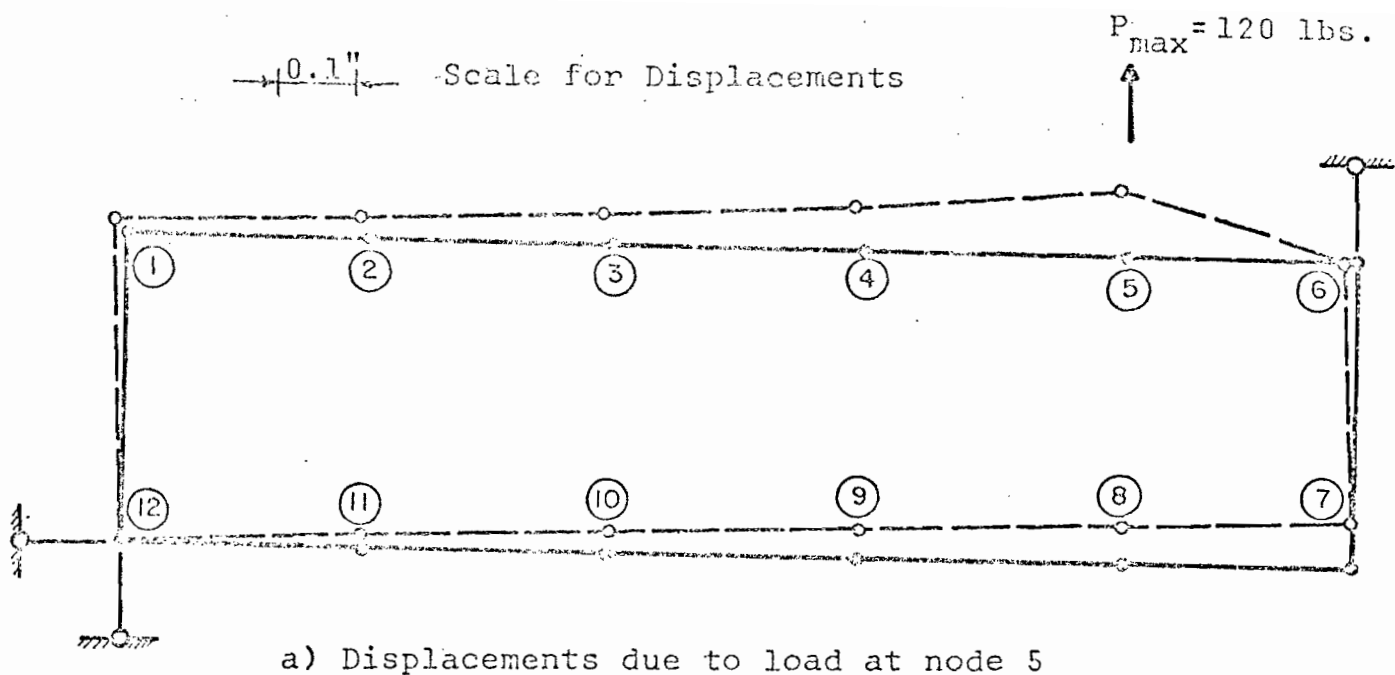

Fig. 25g - Deformation of Corrugated Panel under In-plane Transverse Load.

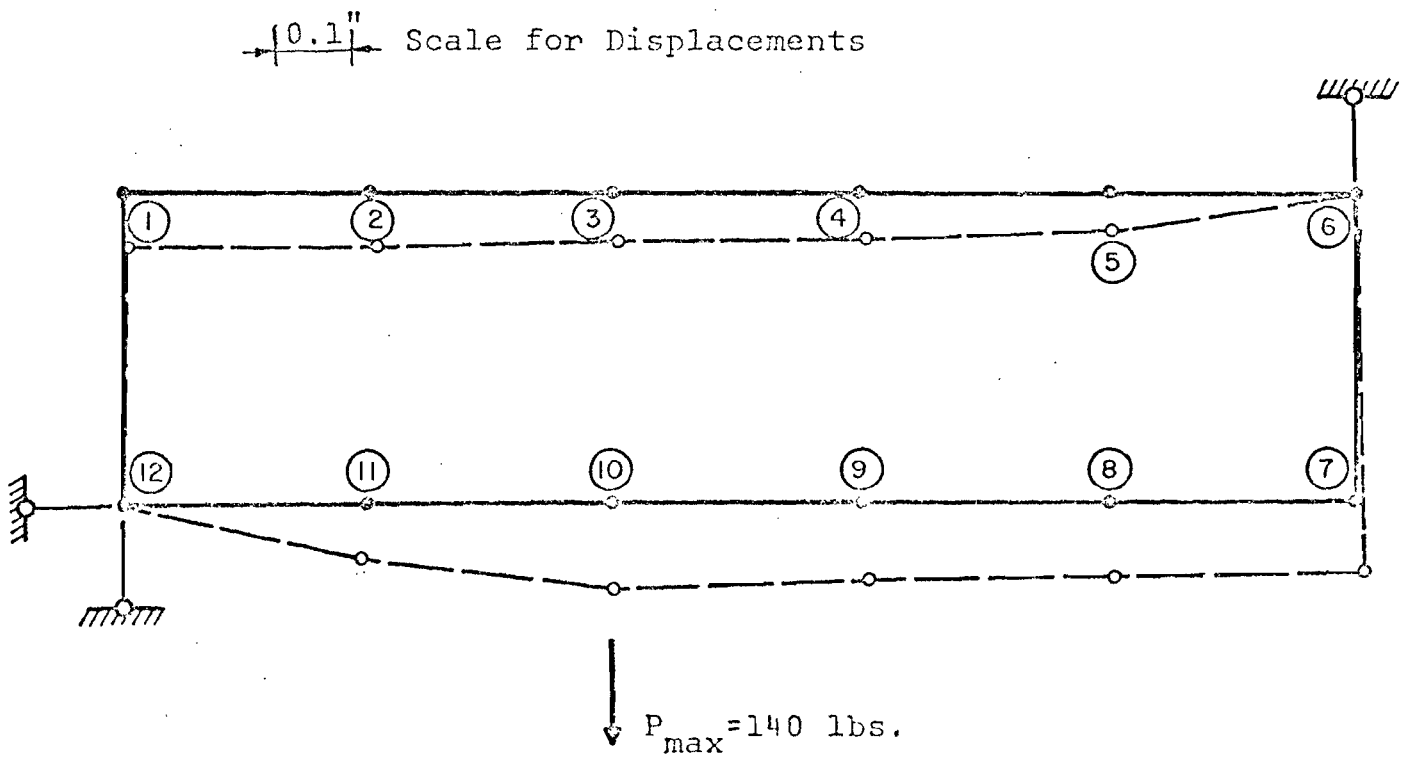
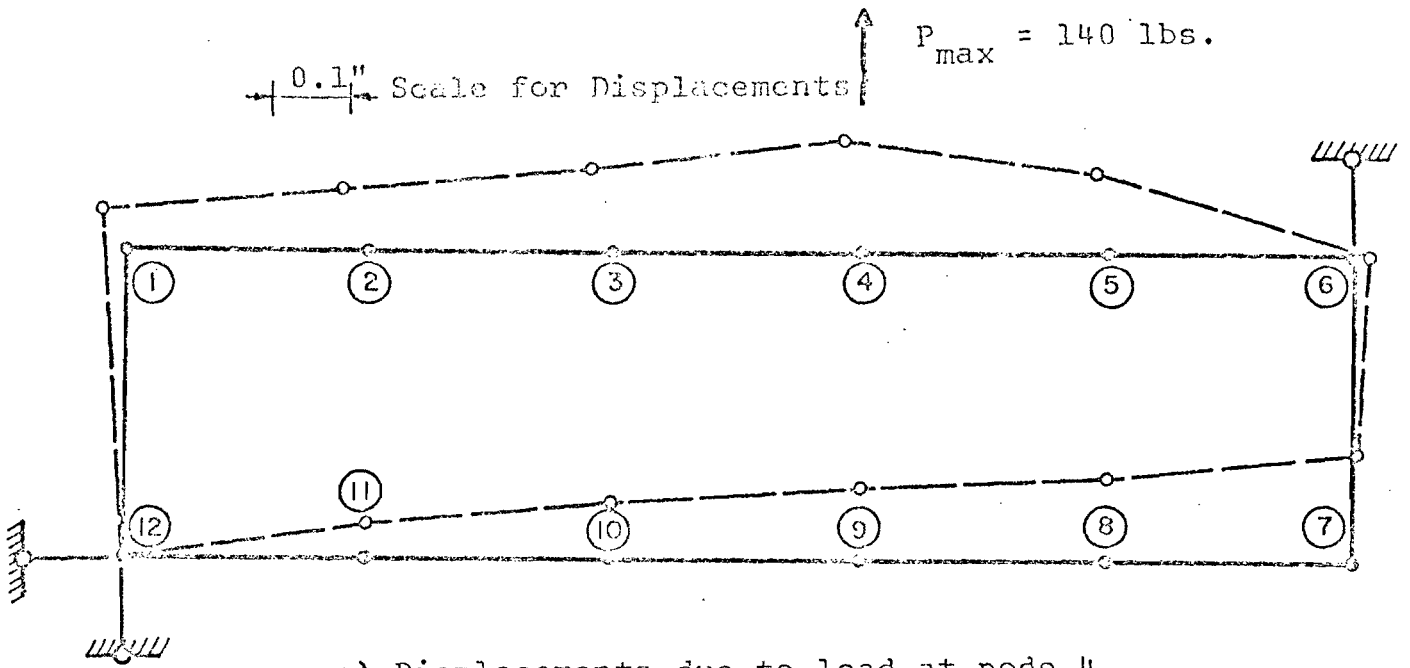

Fig. 25h - Deformation of Corrugated Panel under In-plane Transverse Load

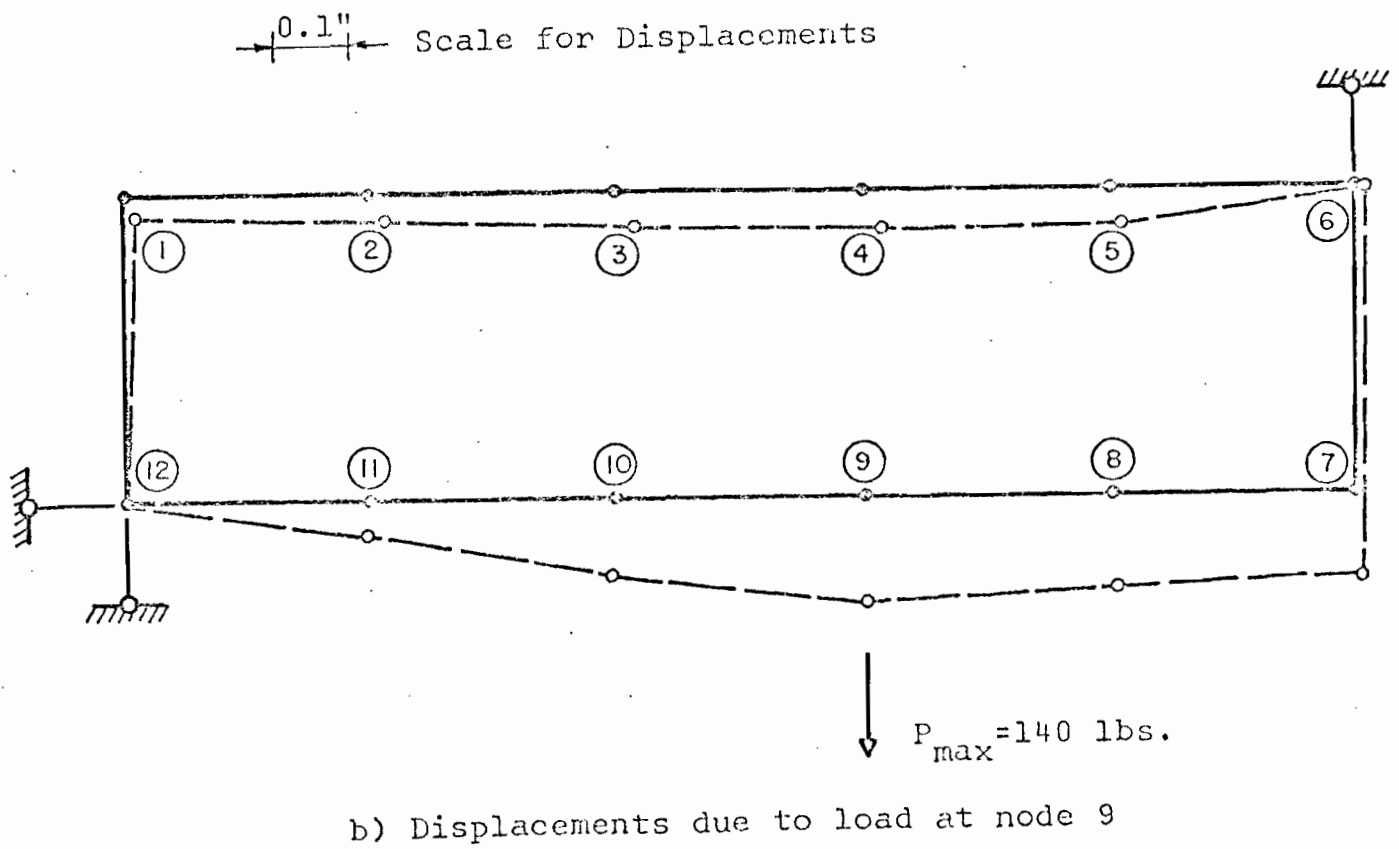
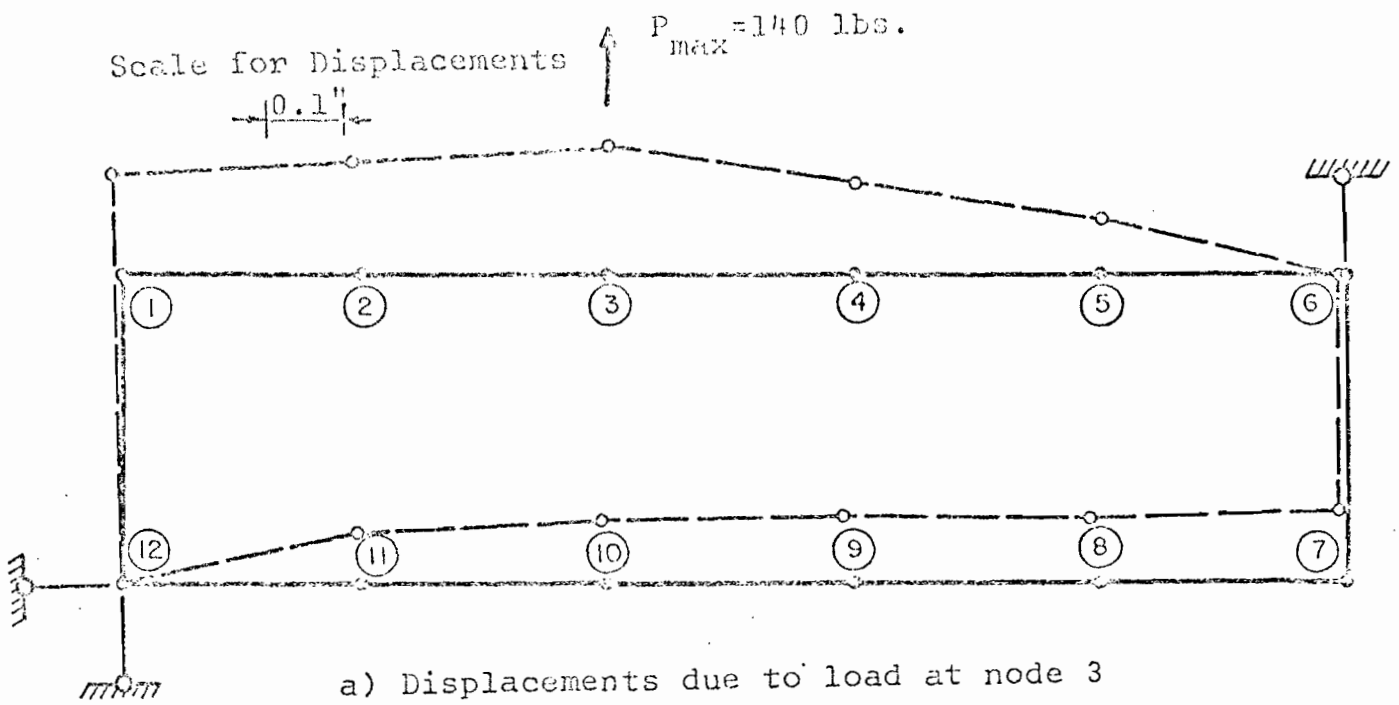

Fig. 25i - Deformation of Corrugated Panel under In-panel Transverse Load

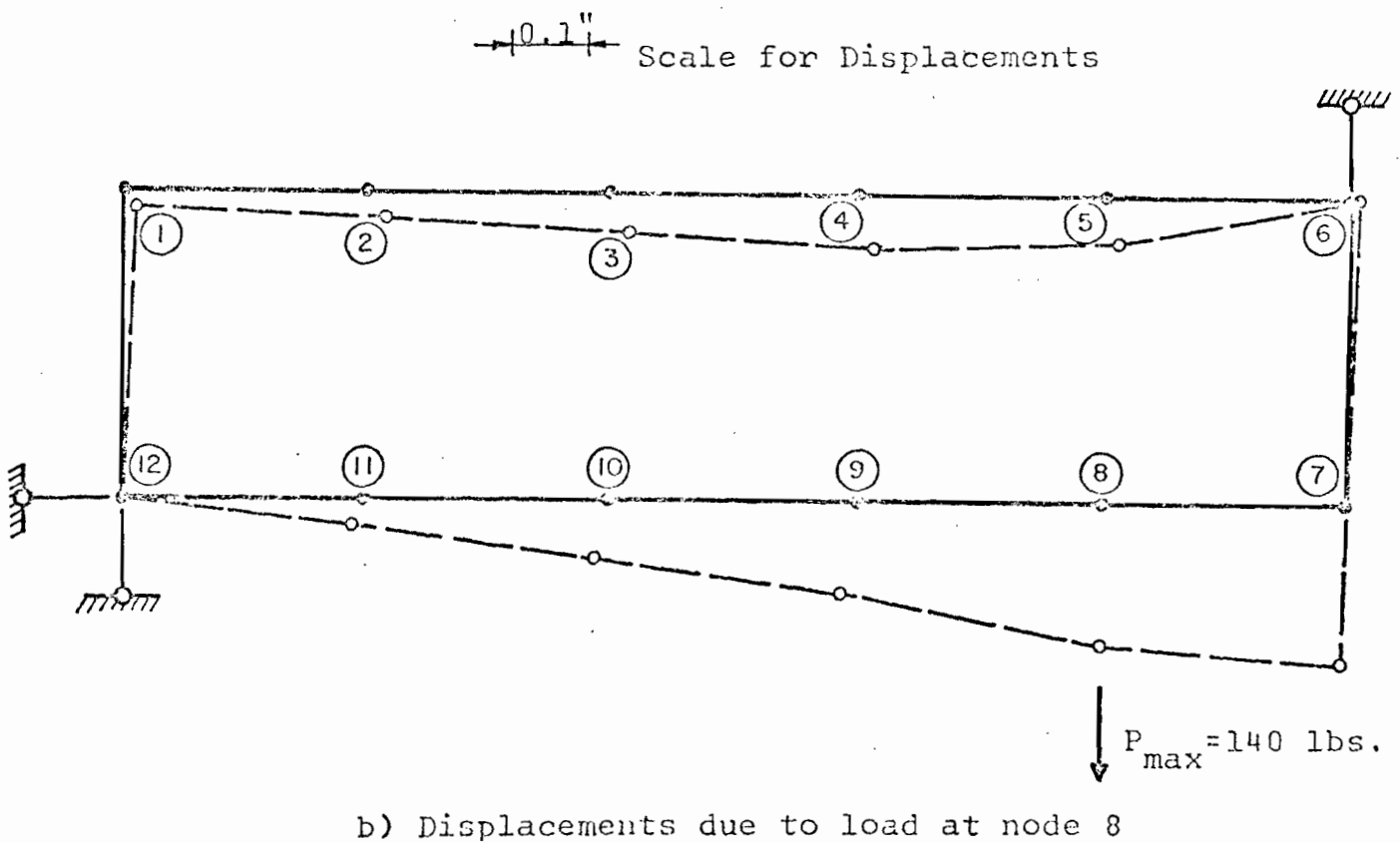
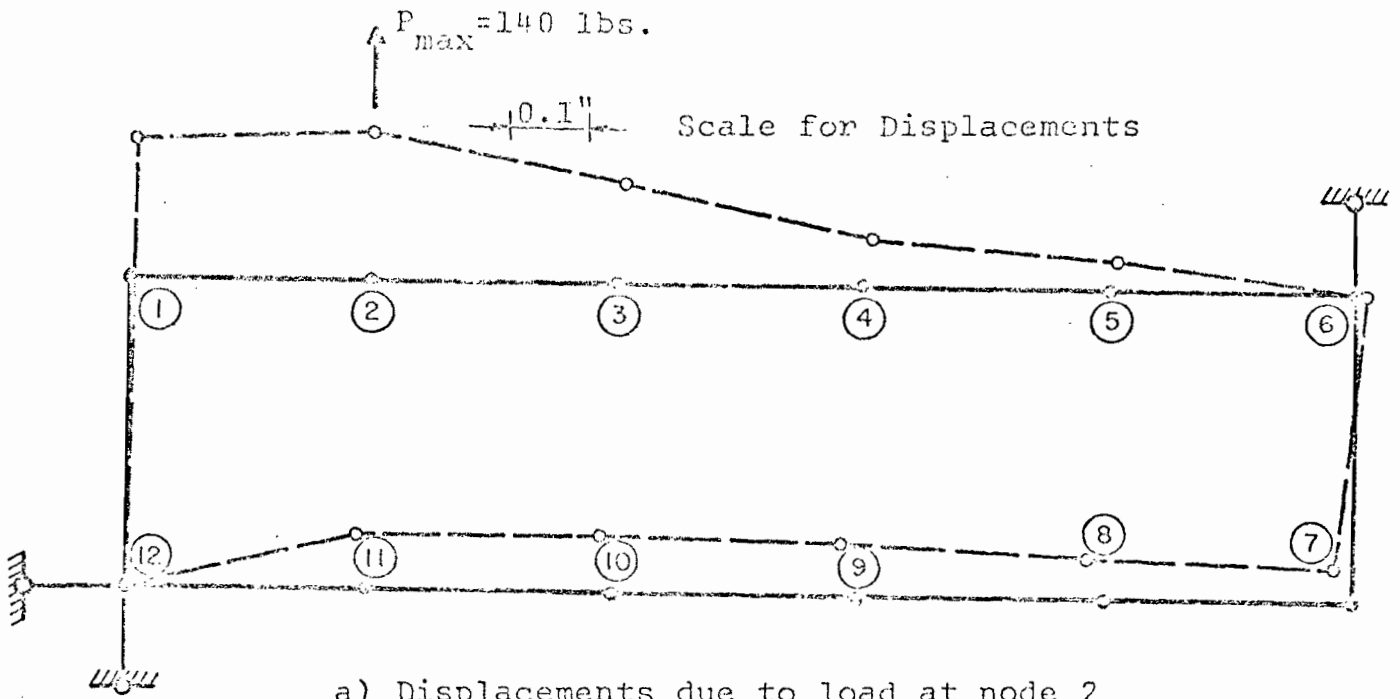

Fig. 25j - Deformation of Corrugated Panel under In-plane Transverse Load

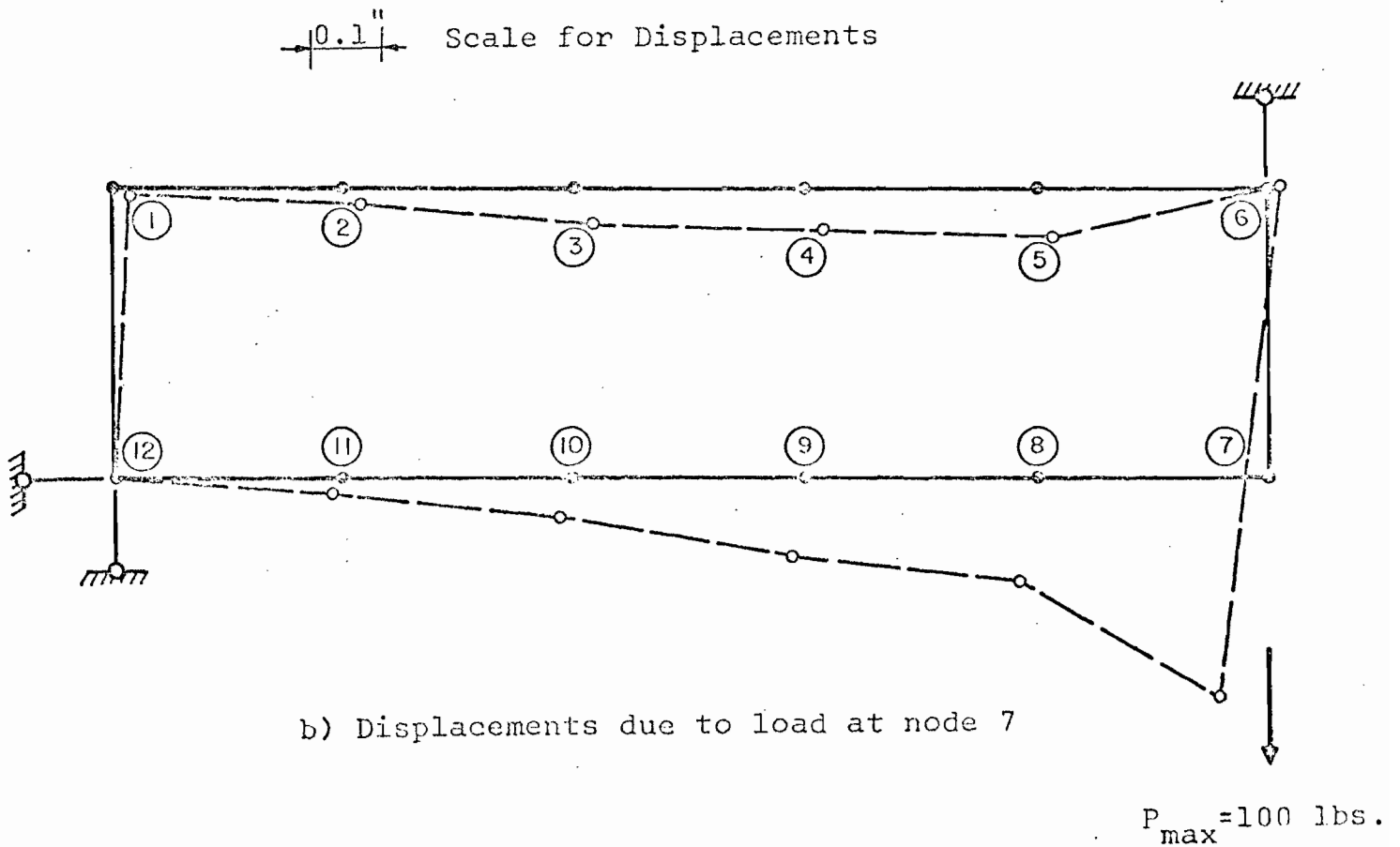
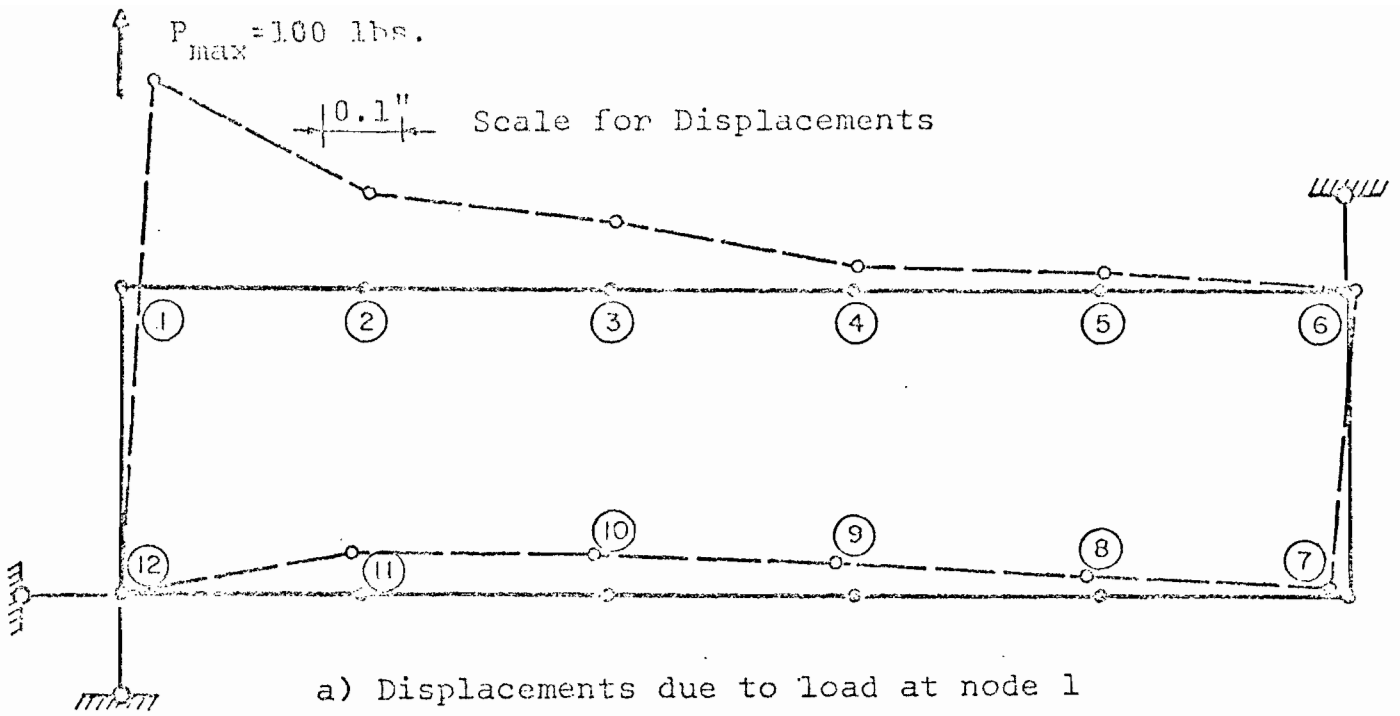

Fig. 25k - Deformation of Corrugated Panel under In-plane Transverse Load