



Missouri University of Science and Technology
Scholars' Mine

AISI-Specifications for the Design of Cold-Formed Steel Structural Members

Wei-Wen Yu Center for Cold-Formed Steel Structures

01 May 2002

Standard for Cold-Formed Steel Framing – General Provisions

American Iron and Steel Institute

Follow this and additional works at: <https://scholarsmine.mst.edu/ccfss-aisi-spec>

 Part of the [Structural Engineering Commons](#)

Recommended Citation

American Iron and Steel Institute, "Standard for Cold-Formed Steel Framing – General Provisions" (2002). *AISI-Specifications for the Design of Cold-Formed Steel Structural Members*. 129. <https://scholarsmine.mst.edu/ccfss-aisi-spec/129>

This Technical Report is brought to you for free and open access by Scholars' Mine. It has been accepted for inclusion in AISI-Specifications for the Design of Cold-Formed Steel Structural Members by an authorized administrator of Scholars' Mine. This work is protected by U. S. Copyright Law. Unauthorized use including reproduction for redistribution requires the permission of the copyright holder. For more information, please contact scholarsmine@mst.edu.

STANDARD
FOR
COLD-FORMED
STEEL FRAMING –
GENERAL PROVISIONS

July 10, 2001

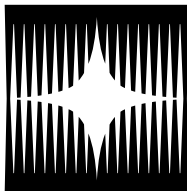

American Iron and Steel Institute

1101 17th Street, NW Suite 1300 Washington, DC 20036-4700

DISCLAIMER

The material contained herein has been developed by the American Iron and Steel Institute Committee on Framing Standards. The Committee has made a diligent effort to present accurate, reliable, and useful information on cold-formed steel framing design and installation. The Committee acknowledges and is grateful for the contributions of the numerous researchers, engineers, and others who have contributed to the body of knowledge on the subject. Specific references are included in the *General Provisions* document.

With anticipated improvements in understanding of the behavior of cold-formed steel framing and the continuing development of new technology, this material may eventually become dated. It is anticipated that AISI will publish updates of this material as new information becomes available, but this cannot be guaranteed.

The materials set forth herein are for general purposes only. They are not a substitute for competent professional advice. Application of this information to a specific project should be reviewed by a design professional. Indeed, in many jurisdictions, such review is required by law. Anyone making use of the information set forth herein does so at their own risk and assumes any and all liability arising there from.

1st Printing – May 2002

Copyright American Iron and Steel Institute 2002

PREFACE

The American Iron and Steel Institute's (AISI's) Committee on Framing Standards (COFS) has developed this *Standard for Cold-Formed Steel Framing - General Provisions* [*General Provisions*] to address all requirements for construction with cold-formed steel framing that are common to prescriptive and engineered design.

The Committee acknowledges and is grateful for the contributions of the numerous engineers, researchers, producers and others who have contributed to the body of knowledge on the subjects. The Committee wishes to also express their appreciation for the support and encouragement of the Steel Framing Alliance.

AISII COMMITTEE ON FRAMING STANDARDS

Jay W. Larson, <i>Chairman</i>	Bethlehem Steel Corporation
Steven Fox, <i>Vice Chairman</i>	Canadian Sheet Steel Building Institute
Kevin Bielat, <i>Secretary</i>	American Iron and Steel Institute
Don Allen	Starzer Brady Fagan Associates, Inc.
John Butts	John F. Butts & Associates, Inc.
Brad S. Cameron	Keymark Engineering
John Carpenter	Alpine Engineered Products
Nader Elhajj	NAHB Research Center
Larry D. Franks	Southern Building Code Congress International, Inc.
Ray Frobosilo	Super Stud Building Products, Inc.
Michael A. Gardner	Gypsum Association
Kirk Grundahl	Steel Truss and Component Association
Richard Haws	Magnatrx Corporation
Jon Henderlong	Malak Properties Inc.
John J. Heydon	Heydon Building Systems
Jeffrey M. Klaiman	ADTEK Engineers
Roger LaBoube	University of Missouri-Rolla
Foster Lyons	Atlantic Structural Fabrications, Inc.
John Maciel	Western Metal Lath
John P. Matsen	Matsen Ford Design Associates, Inc.
Michael A. Meek	Allied Studco
Donald R. Moody	Nucor Steel
Neal Peterson	Steel Stud Manufacturers Association
Dean Peyton	Anderson-Peyton Engineers
Greg Ralph	Dietrich Industries, Inc.
Colin Rogers	McGill University
Gary Rolih	SENCO Fastening Systems
Reynaud Serette	Santa Clara University
Fernando Sesma	CEMCO
Marge Spencer	Compass International, Inc.
Timothy J. Waite	Steel Framing Alliance
Steven Walker	Steven H. Walker, P.Eng.
James Wilcoski	U.S. Army Construction Engineering Research Laboratory
Lei Xu	University of Waterloo
Rahim A. Zadeh	Unimast Incorporated

GENERAL PROVISIONS SUBCOMMITTEE

Don Allen, *Chairman*

Kevin Bielat

John Butts

Nader Elhajj

Richard Haws

Jonathan Humble

Jeffrey M. Klaiman

Roger LaBoube

Jay W. Larson

Hank Martin

John P. Matsen

Dean Peyton

Greg Ralph

Timothy J. Waite

Rahim A. Zadeh

Starzer Brady Fagan Associates, Inc.

American Iron and Steel Institute

John F. Butts & Associates, Inc.

NAHB Research Center

Magnatrax Corporation

American Iron and Steel Institute

ADTEK Engineers

University of Missouri-Rolla

Bethlehem Steel Corporation

American Iron and Steel Institute

Matsen Ford Design Associates, Inc.

Anderson-Peyton Engineers

Dietrich Industries, Inc.

Steel Framing Alliance

Unimast Incorporated

TABLE OF CONTENTS

STANDARD FOR COLD-FORMED STEEL FRAMING – GENERAL PROVISIONS

DISCLAIMER.....	ii
PREFACE.....	iii
AISI COMMITTEE ON FRAMING STANDARDS.....	iv
GENERAL PROVISIONS SUBCOMMITTEE.....	v
A. GENERAL.....	1
A1 Scope.....	1
A2 Definitions	1
A3 Material	3
A4 Corrosion Protection	3
A5 Products	3
A5.1 Base Metal Thickness.....	3
A5.2 Product Designation	4
A5.3 Manufacturing Tolerances	4
A5.4 Product Identification.....	4
A6 Referenced Documents	5
B. MEMBER DESIGN.....	6
B1 Members.....	6
B2 Member Condition	6
B2.1 Web Holes	6
B2.2 Cutting, Patching and Splicing.....	6
B2.2.1 Cutting and Patching.....	6
B2.2.2 Splicing	6
C. INSTALLATION	7
C1 In-Line Framing	7
C2 Non-Structural Wall Framing.....	7
C3 Installation Tolerances	7
C3.1 Foundation	7
C3.2 Ground Contact.....	8
C3.3 Floors.....	8
C3.3.1 Plumbness	8
C3.3.2 Floor Span Capacity.....	8
C3.3.3 Alignment.....	8
C3.3.4 Bearing Width.....	8
C3.3.5 Web Separation.....	8
C3.4 Walls.....	8
C3.4.1 Level and Plumbness.....	8
C3.4.2 Sheathing Span Capacity.....	8
C3.4.3 Alignment.....	8

C3.4.4 End Bearing.....	8
C3.5 Roofs and Ceilings	9
C3.5.1 Level and Plumbness.....	9
C3.5.2 Sheathing Span Capacity.....	9
C3.5.3 Alignment.....	9
C3.5.4 Bearing.....	9
D. CONNECTIONS.....	10
D1 Screw Connections	10
D1.1 Steel to Steel Screws.....	10
D1.2 Sheathing Screws.....	10
D1.3 Installation.....	10
D1.4 Stripped Screws	10
D1.5 Spacing and Edge Distance.....	10
D1.6 Gypsum Board.....	10
D2 Welded Connections	10
D3 Other Connections.....	11
D3.1 Bolts.....	11
D3.2 Other Connectors	11
D3.3 Connection to Other Materials	11
E. MISCELLANEOUS.....	12
E1 Utilities	12
E1.1 Holes	12
E1.2 Plumbing	12
E1.3 Electrical	12
E2 Insulation	12
E2.1 Mineral Fiber Insulation.....	12
E2.2 Other Insulation.....	12

This Page Intentionally Left Blank

STANDARD FOR COLD-FORMED STEEL FRAMING – GENERAL PROVISIONS

A. GENERAL

A1 Scope

These *General Provisions* shall apply to the design, construction and installation of structural and non-structural cold-formed steel framing members where the specified minimum *base metal thickness* is between 18 *mils* (0.0179 inches) (0.457mm) to 118 *mils* (0.1180 inches) (3.00mm). Elements not specifically addressed by this standard shall be constructed in accordance with local building code requirements or an *approved* design. These *General Provisions* shall not preclude the use of other materials, assemblies, structures or designs not meeting the criteria herein, when the other materials, assemblies, structures or designs demonstrate equivalent performance for the intended use to those specified in this standard. Where there is a conflict between these *General Provisions* and other reference documents the requirements contained within the *General Provisions* shall govern.

These *General Provisions* shall include Sections A through E inclusive.

A2 Definitions

Approved. Approved by a building official or *design professional*.

Base Metal Thickness. The thickness of bare steel exclusive of all coatings.

Bracing. Structural elements that are installed to provide restraint or support (or both) to other framing members so that the complete assembly forms a stable structure.

Ceiling Joist. A horizontal structural framing member that supports ceiling components and which may be subject to attic loads.

Cold-Formed Sheet Steel. Sheet steel or strip steel that is manufactured by (1) press braking blanks sheared from sheets or cut length of coils or plates, or by (2) continuous roll forming of cold- or hot-rolled coils of sheet steel; both forming operations are performed at ambient room temperature, that is, without any addition of heat such as would be required for hot forming.

Cripple Stud. A *stud* that is placed between a *header* and a window or door head *track*, a *header* and wall top *track*, or a window sill and a bottom *track* to provide a backing to attach finishing and sheathing material.

C-Shape. A cold-formed steel shape used for structural and non-structural framing members consisting of a *web*, two (2) *flanges* and two (2) *lips* (*edge stiffeners*). (See Fig. A2-1)

Design Professional. An individual who is registered or licensed to practice their respective design profession as defined by the statutory requirements of the state in which the project is to be constructed.

Design Thickness. The steel thickness used in design which is equal to the minimum *base metal thickness* divided by 0.95.

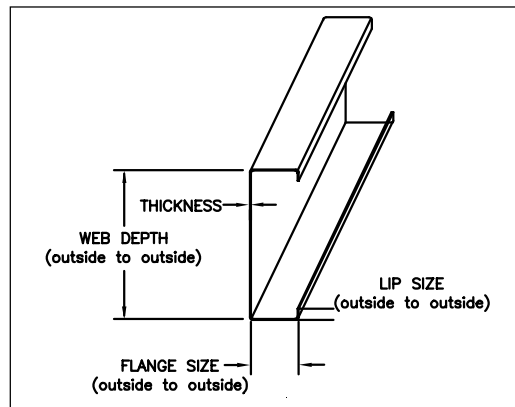

Figure A2-1 C-Shape

Diaphragm. A floor, ceiling or roof assembly designed to resist in-plane forces. (e.g. wind or seismic loads.)

Edge Stiffener. That part of a *C-shape* framing member that extends from the *flange* as a stiffening element that extends perpendicular to the *flange*. (See Fig. A2-1)

Flange. That portion of the *C-shape* framing member or *track* that is perpendicular to the *web*. (See Fig. A2-1)

Floor Joist. A horizontal structural framing member that supports floor loads and superimposed vertical loads.

Header. A horizontal structural framing member used over floor, roof or wall openings to transfer loads around the opening to supporting structural framing members.

In-Line Framing. Framing method where all vertical and horizontal load carrying members are aligned in accordance with C1.

Jack Stud. A *stud* that does not span the full height of the wall and provides bearing for *headers*.

King Stud. A *stud*, adjacent to a *jack stud*, that spans the full height of the wall and supports vertical and lateral loads.

Lip. See *edge stiffener*.

Mil. A unit of measurement equal to 1/1000 inch.

Non-Structural Stud. A member in a steel framed wall system which is limited to a lateral (transverse) load of not more than 5 lb/ft² (240 Pa), a superimposed vertical load, exclusive of sheathing materials, of not more than 100 lb/ft (1460 N/m), or a superimposed vertical load of not more than 200 lbs (890 N).

Punchout. A hole made during the manufacturing process in the *web* of a steel framing member.

Rim Track. A horizontal *structural member* that is connected to the end of a *floor joist*.

Roof Rafter. A horizontal or sloped, structural framing member that supports roof loads.

Shear Wall. A wall assembly designed to resist lateral forces from wind or seismic loads acting parallel to the plane of the wall.

Structural Member. A *floor joist*, *rim track*, *structural stud*, *wall track* in a structural wall, *ceiling joist*, *roof rafter*, *header*, or other member that is designed or intended to carry loads.

Structural Stud. A *stud* in an exterior wall or an interior *stud* which supports superimposed vertical loads and which may transfer lateral loads, including full-height wall *studs*, *king studs*, *jack studs* and *cripple studs*.

Stud. A vertical framing member in a wall system or assembly.

Track. A framing member consisting of only a *web* and two (2) *flanges*. *Track web* depth measurements are taken to the inside of the *flanges*.

Truss. A coplanar system of *structural members* joined together at their ends usually to construct a series of triangles that form a stable beam-like framework.

Yield Strength. A characteristic of the basic strength of the steel material defined as the highest unit stress that the material can endure before permanent deformation occurs as measured by a tensile test in accordance with ASTM A 370.

Web. That portion of a framing member that connects the *flanges*. (see Figure A2-1)

A3 Material

Structural and non-structural framing members utilized in steel construction shall be cold-formed to shape from sheet steel complying with the requirements of ASTM A1003/A1003M.

A4 Corrosion Protection

Structural and non-structural framing members utilized in steel construction shall have a minimum metallic coating complying with the requirements of ASTM A1003/A1003M. Unless additional corrosion protection is provided, framing members shall be located within the building envelope and adequately shielded from direct contact with moisture from the ground or the outdoor climate. Dissimilar metals shall not be used in direct contact with steel framing members. Steel framing members shall not be embedded in concrete, unless *approved* for that purpose.

Fasteners shall have rust inhibitive coating suitable for the installation in which they are being used, or be manufactured from material not susceptible to corrosion.

A5 Products

A5.1 Base Metal Thickness

The material thickness of framing members, in their end-use, shall meet or exceed the minimum *base metal thickness* values given in Table A5.1-1.

Table A5.1-1
Minimum Base Metal Thickness of Cold-Formed Steel Members

Designation (thickness in mils)	Minimum Base Metal Thickness Inches (mm) ¹	Old Reference Gauge Number ²
18	0.0179 (0.455)	25
27	0.0269 (0.683)	22
30	0.0296 (0.752)	20 - Drywall ³
33	0.0329 (0.836)	20 - Structural ³
43	0.0428 (1.09)	18
54	0.0538 (1.37)	16
68	0.0677 (1.72)	14
97	0.0966 (2.45)	12
118	0.1180 (3.00)	10

¹ *Design thickness* shall be the minimum *base metal thickness* divided by 0.95.

² Gauge thickness is an obsolete method of specifying sheet and strip steel thickness. Gauge numbers are only a very rough approximation of steel thickness and shall not be used to order, design or specify any sheet or strip steel product.

³ Historically, 20 gauge material has been furnished in two different thicknesses for structural and drywall (non-structural) applications.

A5.2 Product Designation

The standard designator defined in this section shall be used to identify framing members used in cold-formed steel construction. The designator shall consist of the following sequential codes:

A three or four-digit numeral indicating member *web* depth in 1/100 inch. A letter indicating:

S = *Stud* or joist framing member which have *lips*

T = *Track* section

U = channel or *stud* framing section which do not have *lips*

F = furring channels

L = angle or L-*header*

A three-digit numeral indicating *flange* width in 1/100 inch, followed by a dash. A two or three-digit numeral indicating *base metal thickness* in 1/1000 inch (*mils*).

A5.3 Manufacturing Tolerances

Structural framing members utilized in steel construction shall comply with the manufacturing tolerances listed in ASTM C955. Non-structural framing members utilized in steel construction shall comply with the manufacturing tolerances listed in ASTM C 645.

A5.4 Product Identification

Framing members used in steel construction shall be identified with a legible sticker, stamp, stencil, or embossment, spaced a maximum of 48 inches (1220 mm) on center and located on the *web* of the framing member, in accordance with one of the following standards:

ASTM C645 (Non-structural framing members only)
ASTM C955 (Structural framing members only)
ASTM A1003/A1003M (Framing members not described in ASTM C645
or C955)

A6 Referenced Documents

The following documents are referenced in this *Standard*:

1. AISI, *Specification for the Design of Cold-Formed Steel Structural Members*, 1996 edition with 1999 Supplement, American Iron and Steel Institute, Washington, DC.
2. ASTM, A370-97a, *Standard Test Methods and Definitions for Mechanical Testing of Steel Products*, American Society for Testing and Materials, West Conshohocken, PA.
3. ASTM, A1003/A1003M-00, *Standard Specification for Sheet Steel, Carbon, Metallic and Non-Metallic Coated for Cold-Formed Framing Members*, American Society for Testing and Materials, West Conshohocken, PA.
4. ASTM, B633-94, *Standard Specification for Electrodeposited Coatings of Zinc on Iron and Steel*, American Society for Testing and Materials, West Conshohocken, PA.
5. ASTM, C645-00, *Standard Specification for Nonstructural Steel Framing Members*, American Society for Testing and Materials, West Conshohocken, PA.
6. ASTM, C754-99, *Standard Specification for Installation of Steel Framing Members to Receive Screw-Attached Gypsum Panel Products*, American Society for Testing and Materials, West Conshohocken, PA.
7. ASTM, C955-00, *Standard Specification for Load-Bearing (Transverse and Axial) Steel Studs, Runners (Tracks), and Bracing or Bridging for Screw Application of Gypsum Panel Products and Metal Plaster Bases*, American Society for Testing and Materials, West Conshohocken, PA.
8. AWS, D1.3, *Structural Welding Code-Sheet Steel*, 1998 edition, American Welding Society, Miami, FL.
9. SAE, J78, Revised August 1996, *Steel Self-Drilling Tapping Screws*, Society of Automotive Engineers, Warrendale, PA.

B. MEMBER DESIGN

B1 Members

Framing members shall be designed in accordance with the AISI *Specification for the Design of Cold-Formed Steel Structural Members* [*Specification*].

B2 Member Condition

Framing members shall be as specified by an *approved* design or recognized design standard. The members shall be in good condition. Damaged members shall be replaced or repaired in accordance with the above referenced design or design standard.

B2.1 Web Holes

Holes in *webs* of *studs*, joists and *tracks* shall be in conformance with an *approved* design, the *Specification* or a recognized design standard. *Webs* with holes not conforming to the above shall be reinforced or patched in accordance with an *approved* design or a recognized design standard.

B2.2 Cutting, Patching and Splicing

B2.2.1 Cutting and Patching

Cutting or notching of *flanges* and *lips* of joists, *studs*, *headers*, rafters, *ceiling joists*, and other *structural members*, or the patching of those cuts shall not be permitted without an *approved* design or in accordance with a recognized design standard.

B2.2.2 Splicing

Splicing of joists, *studs* and other *structural members* shall not be performed without an *approved* splice design or in accordance with a recognized design standard.

C. INSTALLATION

C1 In-Line Framing

Each joist, rafter *truss* and structural wall *stud* shall be aligned vertically so that the centerline (mid width) is within 3/4 inch (19 mm) of the centerline (mid width) of the load bearing member beneath per Figure C1-1. The 3/4 inch (19 mm) maximum alignment tolerance is not required when a structural load distribution member is specified in accordance with an *approved* design or a recognized design standard.

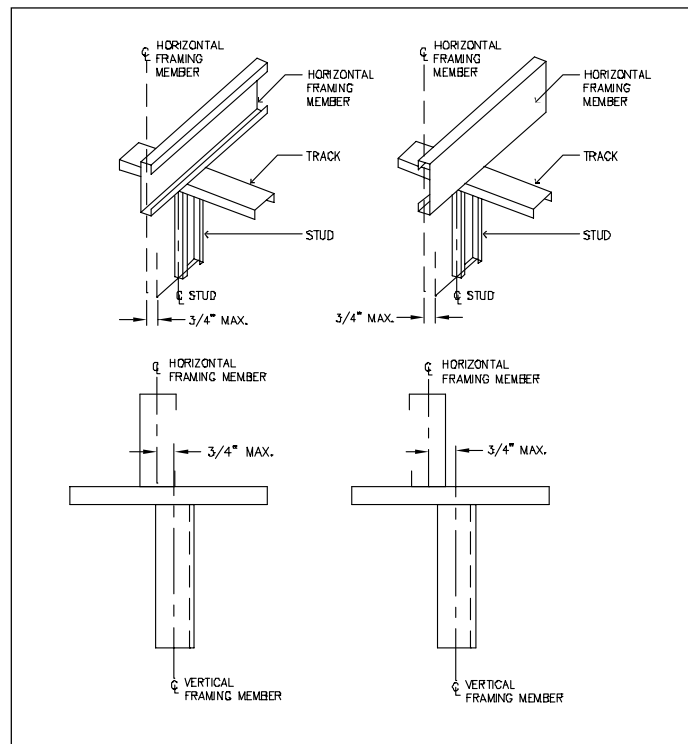

Figure C1-1 In-Line Framing

C2 Non-Structural Wall Framing

Installation of non-structural walls shall be in accordance with ASTM C754.

C3 Installation Tolerances

C3.1 Foundation

Care shall be taken to ensure that the foundation is level and free from defects beneath load bearing walls. If the foundation is not level, provisions shall be made to provide a uniform bearing surface with a maximum 1/4 inch (6.4 mm) gap between the bottom *track* or rim *track* and the foundation. This shall be accomplished through the use of load bearing shims or grout provided between the underside of the wall bottom *track* or *rim track* and the top of the foundation wall or slab at *stud* or joist locations.

C3.2 Ground Contact

Care shall be taken to ensure that the framing shall not be in direct contact with the ground unless specified by an *approved* design. Framing not in direct contact with the ground shall be installed at a sufficient height above the ground in accordance with the local building code.

C3.3 Floors

C3.3.1 Plumbness

Floor joists and *trusses* shall be installed plumb and level, except where specifically designed as sloping members.

C3.3.2 Floor Span Capacity

Floor joist and *truss* spacing shall not exceed the span capacity of the floor sheathing material.

C3.3.3 Alignment

Floor joists and *trusses* shall comply with the alignment requirements of Section C1.

C3.3.4 Bearing Width

Floor joists and *trusses* shall be installed with full bearing over the width of the bearing wall beneath, a minimum 1-1/2 inch (38 mm) bearing end, or in accordance with an *approved* design or recognized design standard.

C3.3.5 Web Separation

Floor joist webs shall not be in direct contact with *rim track webs*.

C3.4 Walls

C3.4.1 Level and Plumbness

Wall *studs* shall be installed plumb, except where specifically designed as sloping members. Wall *track* members shall be installed level except where specifically designed as sloping members.

C3.4.2 Sheathing Span Capacity

Wall *stud* spacing shall not exceed the span capacity of the sheathing material.

C3.4.3 Alignment

Structural wall *studs* shall comply with the alignment requirements of Section C1 for inline framing.

C3.4.4 End Bearing

Ends of structural wall *studs* shall have square end cuts and shall be seated tight and squarely against the *tracks*. For the purpose of this section, seated tight shall mean that a maximum gap tolerance of 1/8 inch (3.2 mm) will be acceptable between the end of wall framing member and the *track*.

C3.5 Roofs and Ceilings

C3.5.1 Level and Plumbness

Roof and ceiling framing members shall be installed plumb and level, except where specifically designed as sloping members.

C3.5.2 Sheathing Span Capacity

The spacing of roof and ceiling framing members shall not exceed the span capacity of the ceiling or roof sheathing material.

C3.5.3 Alignment

Roof and ceiling framing members shall comply with the alignment requirements of Section C1 for inline framing.

C3.5.4 Bearing

Ceiling joists and *trusses* shall be installed with full bearing over the width of the bearing wall beneath or a minimum 1-1/2 inch (38 mm) bearing end condition, or in accordance with an *approved* design or recognized design standard.

D. CONNECTIONS

D1 Screw Connections

D1.1 Steel to Steel Screws

Self-drilling tapping screw fasteners for steel-to-steel connections shall be in compliance with SAE J78 or an *approved* design or recognized design standard. Use of a larger than specified screw size shall be permitted, providing that the minimum spacing and edge distance requirements are met.

D1.2 Sheathing Screws

Self-drilling tapping screw fasteners for structural sheathing to steel connections shall be in compliance with SAE J78 or an *approved* design or recognized design standard.

D1.3 Installation

Screw fasteners shall extend through the steel connection a minimum of three (3) exposed threads. Screw fasteners shall penetrate individual components of connections without causing permanent separation between components.

D1.4 Stripped Screws

Stripped screw fasteners in direct tension shall be considered ineffective. Stripped screw fasteners in shear shall be permitted to be considered effective provided the number of stripped screw fasteners considered effective does not exceed twenty-five percent (25%) of the total number of screw fasteners considered effective in the connection.

D1.5 Spacing and Edge Distance

For screw fasteners in steel-to-steel connections to be considered fully effective, the minimum center-to-center spacing and edge distance shall be 3 times the nominal diameter, except when the edge is parallel to the direction of the applied force the minimum edge distance of screw fasteners shall be 1.5 times the nominal diameter. When the minimum center-to-center spacing is 2 times the nominal diameter, screw fasteners shall be permitted to be considered 80 percent effective.

D1.6 Gypsum Board

Gypsum board shall be attached to steel framing in accordance with the local building code or an *approved* design standard.

D2 Welded Connections

Welded connections shall be in accordance with the *Specification* and AWS D1.3. The design capacity of welds shall be in accordance with the *Specification*.

Welded areas shall be treated with an *approved* treatment to retain the corrosion resistance of the welded area.

D3 Other Connections

D3.1 Bolts

Bolted cold-formed steel connections shall be in accordance with the *Specification*.

D3.2 Other Connectors

Other types of connections (e.g. Pneumatically Driven Fasteners, Powder-Actuated Fasteners, Rivet Fasteners and Clinch Joining) shall be designed, fabricated and installed in accordance with the design requirements as set forth by an *approved* design or recognized design standard, and the fastener manufacturer's requirements.

D3.3 Connection to Other Materials

Bolts, nails, anchor bolts or other fasteners used to connect cold-formed steel framing to wood, masonry, concrete or other steel components shall be designed and installed in accordance with the local building code, an *approved* design or a recognized design standard.

E. MISCELLANEOUS

E1 Utilities

E1.1 Holes

Holes shall comply with the requirements specified in Section B2.1. Penetrations of floor, wall and ceiling/roof assemblies which are required to have a fire resistance rating shall be protected in accordance with the local building code or in accordance with the requirements as stipulated by the authority having jurisdiction.

E1.2 Plumbing

All piping shall be provided with an isolative non-corrosive system to prevent galvanic action or abrasion between framing members and piping.

E1.3 Electrical

Wiring not enclosed in metal conduit shall be separated from the framing members by non-conductive non-corrosive grommets or by other *approved* means.

E2 Insulation

E2.1 Mineral Fiber Insulation

Mineral fiber insulation (e.g. rock wool, glass fiber, etc.) for installation within cavities of framing members shall be full width type insulation and shall be installed in accordance with the requirements as set forth by the local building code and insulation manufacturer. Compression of the insulation is permitted to occur at the open side of the *C-shaped* framing member.

E2.2 Other Insulation

Other types of insulation (e.g. foams, loose fill, etc.) for installation within cavities of framing members shall be installed in accordance with the local building code and insulation manufacturer's requirements. Care is to be taken to ensure that the insulation to be installed will be dimensionally compatible with the steel framing.

COMMENTARY
ON THE
STANDARD
FOR
COLD-FORMED
STEEL FRAMING –
GENERAL PROVISIONS

July 10, 2001

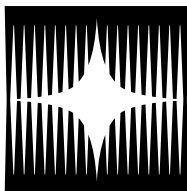

American Iron and Steel Institute

1101 17th Street, NW Suite 1300 Washington, DC 20036-4700

DISCLAIMER

The material contained herein has been developed by the American Iron and Steel Institute Committee on Framing Standards. The Committee has made a diligent effort to present accurate, reliable, and useful information on cold-formed steel framing design and installation. The Committee acknowledges and is grateful for the contributions of the numerous researchers, engineers, and others who have contributed to the body of knowledge on the subject. Specific references are included in the *Commentary on the General Provisions* document.

With anticipated improvements in understanding of the behavior of cold-formed steel framing and the continuing development of new technology, this material may eventually become dated. It is anticipated that AISI will publish updates of this material as new information becomes available, but this cannot be guaranteed.

The materials set forth herein are for general purposes only. They are not a substitute for competent professional advice. Application of this information to a specific project should be reviewed by a *design professional*. Indeed, in many jurisdictions, such review is required by law. Anyone making use of the information set forth herein does so at their own risk and assumes any and all liability arising there from.

1st Printing – May 2002

Copyright American Iron and Steel Institute 2002

PREFACE

This *Commentary* is intended to facilitate the use, and provide an understanding of the background, of the AISI *Standard for Cold-Formed Steel Framing – General Provisions*. The *Commentary* illustrates the substance and limitations of the various provisions of the *Standard*.

In the *Commentary*, sections, equations, figures, and tables are identified by the same notation as used in the *Standard*. Words that are italicized are defined in the *General Provisions Standard*.

AISI COMMITTEE ON FRAMING STANDARDS

Jay W. Larson, <i>Chairman</i>	Bethlehem Steel Corporation
Steven Fox, <i>Vice Chairman</i>	Canadian Sheet Steel Building Institute
Kevin Bielat, <i>Secretary</i>	American Iron and Steel Institute
Don Allen	Starzer Brady Fagan Associates, Inc.
John Butts	John F. Butts & Associates, Inc.
Brad S. Cameron	Keymark Engineering
John Carpenter	Alpine Engineered Products
Nader Elhajj	NAHB Research Center
Larry D. Franks	Southern Building Code Congress International, Inc.
Ray Frobosilo	Super Stud Building Products, Inc.
Michael A. Gardner	Gypsum Association
Kirk Grundahl	Steel Truss and Component Association
Richard Haws	Magnatrax Corporation
Jon Henderlong	Malak Properties Inc.
John J. Heydon	Heydon Building Systems
Jeffrey M. Klaiman	ADTEK Engineers
Roger LaBoube	University of Missouri-Rolla
Foster Lyons	Atlantic Structural Fabrications, Inc.
John Maciel	Western Metal Lath
John P. Matsen	Matsen Ford Design Associates, Inc.
Michael A. Meek	Allied Studco
Donald R. Moody	Nucor Steel
Neal Peterson	Steel Stud Manufacturers Association
Dean Peyton	Anderson-Peyton Engineers
Greg Ralph	Dietrich Industries, Inc.
Colin Rogers	McGill University
Gary Rolih	SENCO Fastening Systems
Reynaud Serette	Santa Clara University
Fernando Sesma	CEMCO
Marge Spencer	Compass International, Inc.
Timothy J. Waite	Steel Framing Alliance
Steven Walker	Steven H. Walker, P.Eng.
James Wilcoski	U.S. Army Construction Engineering Research Laboratory
Lei Xu	University of Waterloo
Rahim A. Zadeh	Unimast Incorporated

GENERAL PROVISIONS SUBCOMMITTEE

Don Allen, *Chairman*

Kevin Bielat

John Butts

Nader Elhajj

Richard Haws

Jonathan Humble

Jeffrey M. Klaiman

Roger LaBoube

Jay W. Larson

Hank Martin

John P. Matsen

Dean Peyton

Greg Ralph

Timothy J. Waite

Rahim A. Zadeh

Starzer Brady Fagan Associates, Inc.

American Iron and Steel Institute

John F. Butts & Associates, Inc.

NAHB Research Center

Magnatrax Corporation

American Iron and Steel Institute

ADTEK Engineers

University of Missouri-Rolla

Bethlehem Steel Corporation

American Iron and Steel Institute

Matsen Ford Design Associates, Inc.

Anderson-Peyton Engineers

Dietrich Industries, Inc.

Steel Framing Alliance

Unimast Incorporated

TABLE OF CONTENTS
COMMENTARY ON THE
STANDARD FOR COLD-FORMED STEEL FRAMING –
GENERAL PROVISIONS

DISCLAIMER	ii
PREFACE	iii
AISI COMMITTEE ON FRAMING STANDARDS	iv
GENERAL PROVISIONS SUBCOMMITTEE	v
A. GENERAL.....	1
A1 Scope.....	1
A2 Definitions	1
A3 Material	1
A4 Corrosion Protection	1
A5 Products	2
A6 Referenced Documents	3
B. MEMBER DESIGN	6
B1 Members.....	6
B2 Member Condition	6
B2.1 Web Holes	6
B2.2 Cutting, Patching and Splicing.....	6
C. INSTALLATION	7
C1 In-Line Framing	7
C2 Non-Structural Wall Framing.....	7
C3 Installation Tolerances	7
C3.1 Foundations.....	7
C3.2 Ground Contact.....	7
C3.3 Floors.....	7
C3.4 Walls.....	7
C3.4 Roofs and Ceilings	8
D. CONNECTIONS.....	9
D1 Screw Connections	9
D1.1 Steel to Steel Screws.....	9
D1.4 Stripped Screws.....	10
D1.5 Spacing and Edge Distance.....	11
D1.6 Gypsum Board.....	11
D2 Welded Connections	11
D3 Other Connections.....	11
E. MISCELLANEOUS.....	12
E1 Utilities	12
E1.1 Holes	12
E1.2 Plumbing	12
E1.3 Electrical	12
E2 Insulation	12
REFERENCES.....	13

COMMENTARY ON THE STANDARD FOR COLD-FORMED STEEL FRAMING – GENERAL PROVISIONS

A. GENERAL

A1 Scope

These *General Provisions* apply to the design, construction, and installation of both structural and non-structural cold-formed steel framing members used for load carrying purposes in buildings. Although these *General Provisions* address the application of framing members having *base metal thickness* between 18 *mils* (0.46 mm) and 118 *mils* (3.0 mm), these *General Provisions* do not preclude the use of other cold-formed steel members, assemblies, structures, or designs when they demonstrate equivalent performance for the intended use to those specified in the *General Provisions*.

These *General Provisions* are intended to serve as a supplement to the AISI *Specification for the Design of Cold-Formed Steel Structural Members* [*Specification*, 1996].

A2 Definitions

Codes and standards by their nature are technical, and as such specific words and phrases can change the intent of the provisions if not properly defined. As a result, it is necessary to establish a common platform by clearly stating the meaning of specific terms for the purpose of these *General Provisions*.

A3 Material

The sheet steel approved for use with these *General Provisions* for either structural or non-structural framing members must comply with ASTM A1003/1003M. ASTM A1003/1003M covers the chemical, mechanical and coating requirements for steel sheet used in the manufacture of cold-formed steel framing members such as *studs*, joists, and *track*.

ASTM A1003/1003M is a relatively new standard which was developed in order to incorporate requirements for metallic-coated, painted metallic-coated, or painted nonmetallic-coated steel sheet used for cold-formed framing members into a single standard. According to the ASTM A1003/1003M standard, Structural Grade Type H steel is intended for structural framing members and Nonstructural Grade steel is intended for non-structural framing members.

A4 Corrosion Protection

The minimum coating specified by these *General Provisions* must comply with ASTM A1003/1003M. ASTM A1003/1003M minimum coating designations assume normal exposure conditions that are best defined as having the framing members enclosed within a building envelope or wall assembly within a controlled environment. When more severe exposure conditions are probable, such as industrial atmospheres and marine atmospheres, consideration should be given to specifying a heavier coating. Coating is specified by weight or mass.

Direct contact with dissimilar metals (e.g. copper, brass, etc.) should be avoided in order to prevent unwanted galvanic action from occurring. Methods for preventing the contact from occurring may be through the use of non-conductive non-corrosive grommets at *web* penetrations or through the use of non-metallic brackets (a.k.a. isolators) fastened to hold the dissimilar metal building products (e.g. piping) away from the steel framing.

Design professionals should take into account both the initial contact with wet or damp building materials, as well as the potential for those materials to absorb water during the building's life, as both circumstances may accelerate corrosion.

In 1996 the American Iron and Steel Institute published a document, entitled *Durability of Cold-Formed Steel Framing Members (Durability, 1996)*, to give engineers, architects, builders and homeowners a better understanding of how galvanizing (zinc and zinc alloy coatings) provides long-term corrosion protection to steel framing members. Additional information can be obtained from the American Galvanizers Association publication entitled *Galvanizing For Corrosion Protection-A Specifier's Guide* (1995) and the Federal Emergency Management Agency's publication entitled *Corrosion Protection for Metal Connectors in Coastal Areas* (1996).

A5 Products

The *Specification for the Design of Cold-Formed Steel Structural Members (Specification, 1996)* permits the minimum delivered thickness of a cold-formed steel member to be 95% of the *design thickness*. These *General Provisions* therefore specify the minimum delivered *base metal thickness* that complies with the AISI *Specification*. The thickness designations and values are consistent with standard industry practice, as published in the Steel Stud Manufacturers Association (SSMA) document *Product Technical Information (Product, 2001)*. It is recommended that thickness measurements be taken in the middle of the flat of the *flange* or *web* of the cross section.

The use of the gauge number when ordering or specifying sheet steel thickness is an obsolete concept. The *General Provisions* list the reference gauge number for informational purposes only.

The Steel Stud Manufacturers Association standard designator has been adopted by the SSMA membership for identifying cold-formed steel framing members (Product, 2001). The intent for using the designation system was to overcome the varied designation approaches that were produced by each individual manufacturer. In addition, the designation is used to identify not only a specific steel framing member, but also in identifying the section properties of that same member through the use of the product technical information document.

The following presents an example of the standard designator for a steel *stud*:

350S162-33 represents a member with the following:

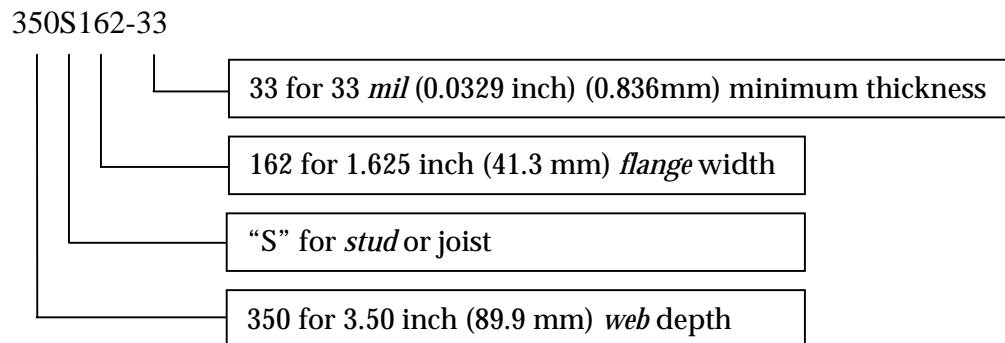

These *General Provisions* employ the use of ASTM C955 and C645, which are the documents that establish the minimum tolerances for the manufacture of load-bearing and non-structural cold-formed steel framing. Both standards contain information regarding the manufacturing tolerances for length, *web* width, camber, bow, twist, etc. of framing members. ASTM C955 covers steel *studs*, *tracks*, and *bracing* having a base steel thickness of not less than 0.0329 in. (0.836 mm) for screw application of gypsum panel products and metal plaster bases. ASTM C645 covers steel *studs* and *tracks* having a *base metal thickness* of not less than 0.0179 inches (0.455 mm) for screw application of gypsum panel products and metal plaster bases for interior construction assemblies. Tables A5-1 and A5-2 summarize the ASTM specified tolerances.

To aid in shop and field verification, all framing members are to carry a product identification to indicate conformance with the minimum sheet steel thickness, coating designation, minimum *yield strength*, and manufacturer's name. A list of the specific information is contained in the "marking and identification" sections of ASTM C645, C955 and A1003/1003M.

A6 Referenced Documents

The referenced documents pertain to various aspects of cold-formed steel design and behavior. All of the documents that are listed in this section are referenced in the *General Provisions*.

Table A5-1
 ASTM C 955-00 Manufacturing Tolerances for Structural Members
 (See Figure A5-1)

Dimension ¹	Item Checked	Studs, in. (mm)	Tracks, in. (mm)
A	Length	+3/32 (2.38)	+ 1/2 (12.7)
		-3/32 (2.38)	-1/4 (6.35)
B ²	Web Depth	+1/32 (0.79)	+1/32 (0.79)
		-1/32 (0.79)	+1/8 (3.18)
C	Flare	+1/16 (1.59)	+0 (0)
	Overbend	-1/16 (1.59)	-3/32 (2.38)
D	Hole Center Width	+1/16 (1.59)	NA
		-1/16 (1.59)	NA
E	Hole Center Length	+1/4 (6.35)	NA
		-1/4 (6.35)	NA
F	Crown	+1/16 (1.59)	+1/16 (1.59)
		-1/16 (1.59)	-1/16 (1.59)
G	Camber	1/32 per ft (2.6 per m)	1/32 per ft (2.6 per m)
		1/2 max (12.7)	1/2 max (12.7)
H	Bow	1/32 per ft (2.6 per m)	1/32 per ft (2.6 per m)
		1/2 max (12.7)	1/2 max (12.7)
I	Twist	1/32 per ft (2.6 per m)	1/32 per ft (2.6 per m)
		1/2 max (12.7)	1/2 max (12.7)

¹ All measurements shall be taken not less than 1 ft (305 mm) from the end.

² Outside dimension for *stud*; inside for *track*.

Table A5-2
 ASTM C 645-00: Manufacturing Tolerances for Non-Structural Members
 (See Figure A5-1)

Dimension ¹	Item Checked	Studs, in. (mm)	Tracks, in. (mm)
A	Length	+1/8 (3.18)	+ 1(25.40)
		-1/4 (6.35)	-1/4 (6.35)
B ²	Web Depth	+1/32 (0.79)	+1/8 (3.18)
		-1/32 (0.79)	-0 (0)
C	Flare	+1/16 (1.59)	+0 (0)
	Overbend	-1/16 (1.59)	-3/16 (4.76)
D	Hole Center Width	+1/8 (3.18)	NA
		-1/8 (3.18)	NA
E	Hole Center Length	+1/4 (6.35)	NA
		-1/4 (6.35)	NA
F	Crown	+1/8 (3.18)	+ 1/8 (3.18)
		-1/8 (3.18)	- 1/8 (3.18)
G	Camber	1/32 per ft. (2.6 per m)	1/32 per ft (2.6 per m)
		1/2 max (12.7)	1/2 max (12.7)
H	Bow	1/32 per ft (2.6 per m)	1/32 per ft (2.6 per m)
		1/2 max (12.7)	1/2 max (12.7)
I	Twist	1/32 per ft (2.6 per m)	1/32 per ft (2.6 per m)
		1/2 max (12.7)	1/2 max (12.7)

¹ All measurements shall be taken not less than 1 ft (305 mm) from the end.

² Outside dimension for *stud*; inside for *track*.

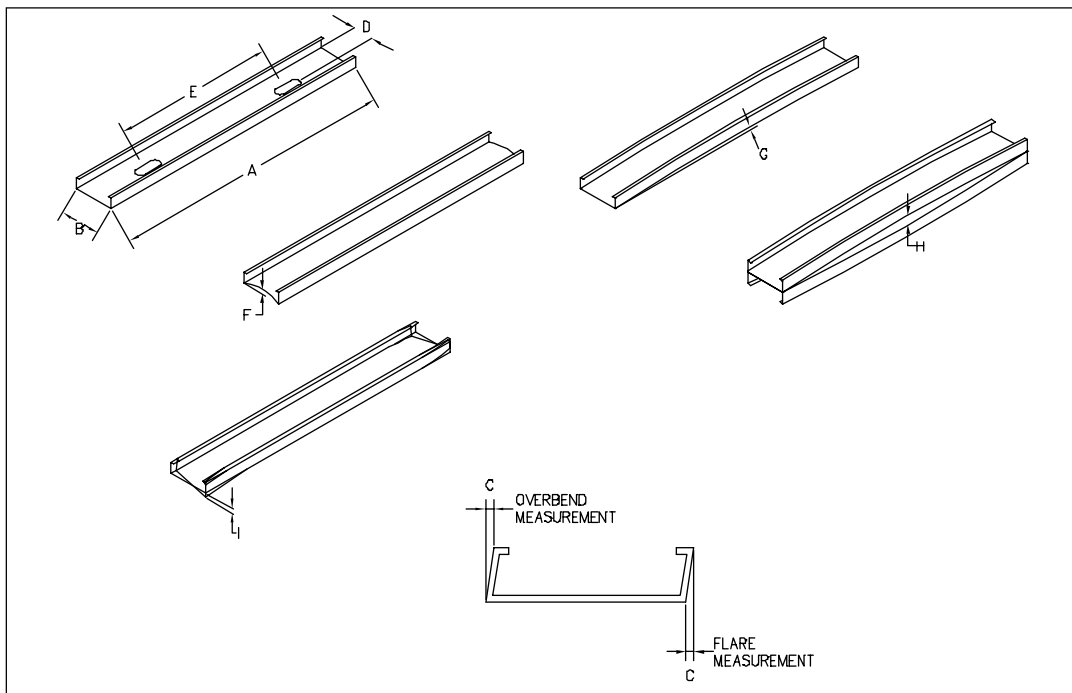

Figure A5-1 Manufacturing Tolerances

B. MEMBER DESIGN

B1 Members

The strength determinations required by the *General Provisions* are to be in accordance with the AISI *Specification* (*Specification*, 1996). Either the Allowable Stress Design (ASD) method or the Load and Resistance Factor Design (LRFD) method is permitted to be used in association with the *General Provisions*. For design guidance on the application of the *Specification* to typical cold-formed steel construction refer to *Design Guide for Cold-Formed Steel Framing* (Design, 2002) and *Cold-Formed Steel Design* (Yu, 2000).

B2 Member Condition

To ensure structural performance is in compliance with the engineered design, framing members must not be damaged. Damage assessment is not within the purview of these *General Provisions*. The *design professional* should be consulted when damage alters the cross-section geometry of a framing member beyond the specified tolerances.

B2.1 Web Holes

The AISI *Specification* (1996) stipulates design requirements for members with standard *web* holes. In the field these “*web* holes” may also be referred to as “*punchouts*”, “*utility holes*”, “*perforations*” and “*web penetrations*”. In structural framing members, *web* holes are typically 1.5 in. (38 mm) wide x 4 in. (102 mm) long and are located on the centerline of the *web*. The *web* holes are generally spaced 24 in. (610 mm) on-center.

B2.2 Cutting, Patching, and Splicing

Coping, cutting or notching of *flanges* and *edge stiffeners* is not permitted for load bearing members without an *approved* design. For guidance on design for coped members in *trusses* refer to *Standard for Cold-Formed Steel Framing – Truss Design* (AISI, 2001).

Structural members may be spliced, however splicing of *studs* and joists is not a common practice and is not recommended. If a *structural member* requires splicing, the splice connection must be installed in accordance with an *approved* design.

C. INSTALLATION

C1 In-Line Framing

In-line framing is the preferred and most commonly used framing method. The advantage of *in-line framing* is that it provides a direct load path for transfer of forces from joists to *studs*. The *General Provisions* stipulate maximum framing alignment to minimize secondary moments on the framing members. The 3/4 in. (19 mm) alignment value is accepted industry practice. Weak axis bending strength of *track* is minimal and therefore the *track* cannot function as a load transfer member. In the absence of *in-line framing*, a load distribution member, such as a structural *track*, may be required for this force transfer.

C2 Non-Structural Wall Framing

The *General Provisions* do not require *in-line framing* for non-structural wall framing. Non-structural framing is to be installed as prescribed by ASTM C754. ASTM C754 covers the minimum requirements for the installation of interior non-structural steel framing and furring designed to receive screw-attached gypsum board.

C3 Installation Tolerances

C3.1 Foundations

An uneven foundation may cause problems. The specified 1/4 in. (6.4 mm) gap has been deemed acceptable industry practice.

C3.2 Ground Contact

To minimize the potential for corrosion, care must be taken to avoid direct contact between the steel framing and the ground. In addition to direct contact, it is important to minimize the potential for corrosion resulting from ambient moisture. The local building code is cited as the authoritative document which will provide guidance concerning minimum separation distances from the ground to the framing member, installation requirements for moisture barriers, and the necessary ventilation of the space.

C3.3 Floors

To avoid premature failure at a support and to achieve *in-line framing*, full bearing of the joist on its supporting wall is necessary. The intent of specifying that the *track* and joist *webs* are not to be in direct contact with each other is to prevent floors from creating an unwanted noise (e.g. squeaks).

C3.4 Walls

Wall *studs* must be installed plumb to avoid the potential for secondary bending moments in the member from occurring. The *stud* should be nested or seated into the *track* to provide for adequate transfer of the forces. The maximum gap tolerance specified by the *General Provisions* is based on accepted industry practice and is not required for non-structural walls.

C3.5 Roofs and Ceilings

Proper installation and alignment of *roof* and *ceiling joists* is necessary to ensure the proper load transfer from the rafter/*ceiling joist* connection to the wall framing. To avoid premature failure at a support and to achieve *in-line framing*, full bearing of the joist on its supporting wall framing member or a minimum 1-1/2 inch (38 mm) end bearing is necessary.

D. CONNECTIONS

D1 Screw Connections

D1.1 Steel to Steel Screws

Self-drilling screws are the primary fastener type used in cold-formed steel construction, although the *General Provisions* do not preclude the use of other fastener types. In the absence of an ASTM standard for a self-drilling screw, design requirements have relied on other industry standards. SAE J78 covers dimensional and general specifications for carbon steel self-drilling screws. SAE J78 applies to the installation performance. The tensile or shear strength must be defined by test in accordance with the *AISI General Provisions Test Methods for Determining the Tensile and Shear Strength of Screws* (2001). General guidance on the selection of self-drilling screws is given by the Light Gauge Steel Engineers Association document *Screw Fastener Selection for Light Steel Framing* (Light, 1997).

Proper selection and installation of screws is necessary to ensure the design performance. Self-drilling screws are specified using a nominal size designator, not by diameter. Table D1-1 defines suggested nominal screw diameters. The installation requirements stated in the *General Provisions* are based on industry practice. Selection of a minimum screw size is based on the total sheet thickness of the connection. Where recommendations are not available, Table D1-2 provides suggested screw size for steel-to-steel connections.

Table D1-1
Suggested Screw Body Diameter

Screw Nominal Size	Nominal Screw Diameter, d, in.
No. 6	0.138
No. 8	0.164
No. 10	0.190
No. 12	0.216
1/4"	0.250



For SI: 1 inch = 25.4 mm.

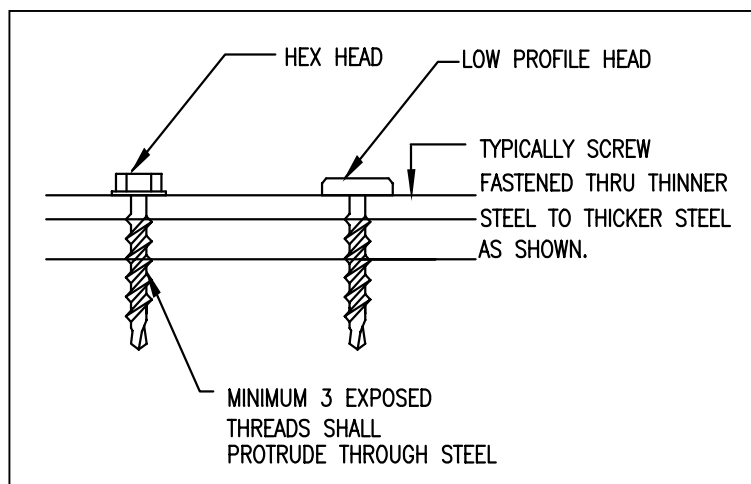

Figure D1-1 - Screw Grip Range

Table D1-2
Suggested Screw Sizes For Steel-to-Steel Connections

Screw Size	Point Style	Total Thickness of Steel ¹ (inches)
¼	1	0.024 – 0.095
6	2	0.036 – 0.100
8	2	0.036 – 0.100
10	2	0.036 – 0.110
12	2	0.050 – 0.140
14	2	0.060 – 0.120
18	2	0.060 – 0.120
8	3	0.100 – 0.140
10	3	0.110 – 0.175
12	3	0.090 – 0.210
14	3	0.110 – 0.250
12	4	0.175 – 0.250
¼	4	0.175 – 0.250
12	4.5	0.145 – 0.312
12	5	0.250 – 0.500
¼	5	0.250 – 0.500

¹The combined thickness of all connected steel members
1 in. = 25.4 mm

D1.4 Stripped Screws

It is unreasonable to expect that there will be no stripped screws in a connection. Research at the University of Missouri-Rolla, (Sokol et al., 1999) has shown that the structural performance of a single-shear screw connection is not compromised if screws in the connection have been inadvertently stripped during installation. This research serves as the basis for the requirements of the *General Provisions*.

D1.5 Spacing and Edge Distance

The AISI *Specification (Specification, 1996)* stipulates that the center-to-center spacing of screws be at least 3 times the screw diameter. During installation if this spacing is only 2 times the diameter, research at the University of Missouri-Rolla (Sokol et al., 1999) has shown that the structural performance of the connection is reduced. Guidelines for center-to-center spacing of less than 2 times the diameter are not stipulated because the screw head diameter precludes a smaller spacing. The University of Missouri-Rolla research serves as the basis for the requirements in the *General Provisions*.

D1.6 Gypsum Board

The *General Provisions* employ the use of the local building code as the guide or provisions that cover the installation and attachment of gypsum panels to steel framing. The national model building codes of the United States contain an entire chapter on gypsum panel attachment. The model building codes reference ASTM C754 and C1007 as the appropriate standards for the gypsum board attachment to steel framing.

D2 Welded Connections

To maintain acceptable durability of a welded connection, the weld area must be treated with a corrosion resistant coating, such as a zinc-rich paint. Additional guidance on welding of cold-formed steel members is provided in the Light Gauge Steel Engineers Association document *Welding Cold-Formed Steel* (Light, 1999a).

D3 Other Connections

The *General Provisions* permit the use of bolts and proprietary fasteners, such as pneumatically driven pins, powder-actuated fasteners, rivets, adhesives, and clinches. Bolts can be designed by the AISI *Specification* equations. However, proprietary fasteners must be designed and installed in accordance with the manufacturers' requirements. The factor of safety to be used in design is to be determined by Chapter F of the AISI *Specification*. The Light Gauge Steel Engineers Association publishes technical notes pertaining to powder actuated fasteners, clinching, and pneumatically driven pins (Light, 2001; Light, 1999b; Light, 1998).

E. MISCELLANEOUS

E1 Utilities

E1.1 Holes

The design should include references to pre-punch hole sizes or limitations to accommodate electrical, telecommunication, plumbing and mechanical systems. Field-cut holes are generally discouraged, but are not uncommon. Field cut holes, if necessary, are required to comply with Section B2.1. There are several methods whereby holes can be cut in the field, such as a hole-punch, hole saws, and plasma cutters.

Holes that penetrate an assembly, containing steel framing that has a fire resistance rating, will need to be designed with through-penetration firestop systems. The acceptance of this fire resistance design is based on the local building code.

E1.2 Plumbing

Direct contact with copper piping should be avoided in order to prevent galvanic action from occurring. Methods for preventing the contact from occurring may be through the use of non-conductive non-corrosive grommets at *web* penetrations or through the use of non-metallic brackets (a.k.a. isolators) fastened to hold the dissimilar metal building products (e.g. piping) away from the steel framing. Plastic pipe does not require protection if it is in contact with the steel framing member, but consideration should be made for the installation of non-metallic brackets to hold the pipe away from the hole in the steel in order to prevent noise and prevent the steel from potentially creating an incision into the pipe.

E1.3 Electrical

Non-metallic sheathed wiring must be separated from the steel-framing member in order to comply with the *National Electrical Code* (National, 1999). Contained within the *National Electrical Code* is a provision that requires non-metallic sheathed cable to “be protected by bushings or grommets securely fastened in the opening prior to the installation of the cable.” Cable following the length of a framing member will need to be secured (e.g. supported) at set lengths, for this purpose small holes in the *web* may be beneficial for the attachment of tie-downs (e.g. nylon cable ties, nylon zipper ties, etc). When installing wiring or cables within a framing member (e.g. through or parallel to member) the intent of the NFPA NEC further requires that the wiring or cables be located 1-1/4 inches (32 mm) from the edge of the framing member. When 2-1/2 inch (64 mm) wide wall *studs* are used, the restrictions concerning edge clearance apply.

E2 Insulation

The cavity insulation must be installed such that the width of the insulation extends from the face of the *web* of one framing member to the face of the *web* of the next framing member. In the case of steel framing, designs should specify “full width” insulation in order to differentiate the insulation that is normally supplied (a.k.a. nominal width).

To enhance the thermal performance of steel framed construction, board insulation (a.k.a. continuous insulation or insulating sheathing) may be used in conjunction with cavity insulation. Guidance on the use of board and batt insulation is given in *Thermal Design Guide for Exterior*

Walls (AISI, 1995). Designs should also take into consideration the effects of moisture when assessing the application of both cavity and continuous insulation, in this case dew point. The ASHRAE *Handbook of Fundamentals*, Chapters 23 and 24 of the 2001 edition, contains information useful for determining dew point. (ASHRAE, 2001).

For additional information pertaining to thermal performance of cold-formed steel framing in homes see “Energy Code and Related Thermal Performance Issues Associated With Steel Framing in Homes” (National, 1997).

REFERENCES

- Thermal Design Guide for Exterior Walls* (1995), RG-9405, American Iron and Steel Institute, Washington, D.C.
- ASHRAE Handbook Fundamentals* (2001), American Society of Heating Refrigerating and Air-conditioning Engineers, Atlanta, GA.
- Corrosion Protection for Metal Connectors in Coastal Areas for Structures Located in Special Flood Hazard Areas in Accordance with the National Flood Insurance Program* (1996), *Technical Bulletin 8-96*, Federal Emergency Management Agency, Washington, DC.
- Design Guide for Cold-Formed Steel Framing* (2002), CF02-1, American Iron and Steel Institute, Washington, D.C.
- Durability of Cold-Formed Steel Framing Members* (1996), American Iron and Steel Institute, Washington, D.C.
- Galvanizing For Corrosion Protection-A Specifier's Guide* (1995), American Galvanizers Association, Aurora, CO.
- Light Gauge Steel Engineers Association (1998), “Pneumatically Driven Pins for Wood Based Panel Attachment”, Tech Note 561b, Washington, D.C.
- Light Gauge Steel Engineers Association (1997), “Screw Fastener Selection for Light Steel Framing”, Tech Note 565c, Washington, D.C.
- Light Gauge Steel Engineers Association (1999), “Welding Cold-Formed Steel”, Tech Note 560-b1, Washington, D.C.
- Light Gauge Steel Engineers Association (1999), “Clinched (Integral) Fastening of Cold-Formed Steel”, Tech Note 560c, Washington, D.C.
- Light Gauge Steel Engineers Association (2001), “Powder Actuated Fasteners in Cold-Formed Steel Construction”, Tech Note 562, Washington, D.C.
- National Association of Home Builders (1997), “Energy Code and Related Thermal Performance Issues Associated with Steel Framing in Homes”, Upper Marlboro, MD.
- National Electrical Code (NFPA 70)* (1999), National Fire Protection Association, Quincy, MA.
- Product Technical Information* (2001), (ICBO ER-4943P), Steel Stud Manufacturers Association

Sokol, M.A., LaBoube, R.A., and Yu, W.W. (1999), "Determination of the Tensile and Shear Strengths of Screws and the Effect of Screw Patterns on Cold-Formed Steel Connections," Civil Engineering Study 98-3, Cold-Formed Steel Series, Center for Cold-Formed Steel Structures, University of Missouri-Rolla, Rolla, MO.

Specification for the Design of Cold-Formed Steel Structural Members (1996), with 1999 Supplement, American Iron and Steel Institute, Washington, D.C.

Standard for Cold-Formed Steel Framing – Truss Design (2001), American Iron and Steel Institute, Washington, D.C.

Standard Specification for Nonstructural Steel Framing Members (2000), ASTM C645, American Society for Testing and Materials, West Conshohocken, PA.

Standard Specification for Installation of Steel Framing Members to Receive Screw-Attached Gypsum Panel Products (1999), ASTM C754, American Society for Testing and Materials, West Conshohocken, PA.

Standard Specification for Load-Bearing (Transverse and Axial) Steel Studs, Runners (Tracks), and Bracing or Bridging for Screw Application of Gypsum Board and Metal Plaster Bases (2000), ASTM C955, American Society for Testing and Materials, West Conshohocken, PA.

Standard Specification for Steel Sheet, Carbon, Metallic- and Nonmetallic-Coated for Cold-Formed Framing Members (2000), ASTM A1003/1003M, American Society for Testing and Materials, West Conshohocken, PA.

Self-Drilling Tapping Screws (1996), SAE J78, Society of Automotive Engineers (SAE), Warrendale, PA.

Yu, W.W. (2000), *Cold-Formed Steel Design*, 3rd Edition, John Wiley & Sons, New York, NY.