

Georgia Southern University Digital Commons@Georgia Southern

Electrical & Computer Engineering, Department of
- Faculty Research & Publications

Electrical & Computer Engineering, Department of

2015

Smart Grids Technology Fundamentals - New Course

Adel El-Shahat

Georgia Southern University, aahmed@georgiasouthern.edu

Rami J. Haddad

Georgia Southern University, rhaddad@georgiasouthern.edu

Youakim Kalaani

Georgia Southern University, yalkalaani@georgiasouthern.edu

Follow this and additional works at: <https://digitalcommons.georgiasouthern.edu/electrical-eng-facpubs>

 Part of the [Electrical and Computer Engineering Commons](#)

Recommended Citation

El-Shahat, Adel, Rami J. Haddad, Youakim Kalaani. 2015. "Smart Grids Technology Fundamentals - New Course." *Proceedings of the ASEE Southeastern Section Annual Conference* Gainesville, FL: American Society for Engineering Education. source: <http://www.asee-se.org/proceedings/ASEE2015/papers2015/116.pdf>
<https://digitalcommons.georgiasouthern.edu/electrical-eng-facpubs/12>

This conference proceeding is brought to you for free and open access by the Electrical & Computer Engineering, Department of at Digital Commons@Georgia Southern. It has been accepted for inclusion in Electrical & Computer Engineering, Department of - Faculty Research & Publications by an authorized administrator of Digital Commons@Georgia Southern. For more information, please contact digitalcommons@georgiasouthern.edu.

Smart Grids Technology Fundamentals – A New Course Model

Adel El Shahat, Rami J. Haddad, Youakim Kalaani

*Electrical Engineering Department,
Allen E. Paulson College of Engineering and Information Technology,
Georgia Southern University*

Abstract

In this paper, a new course in smart grid technologies to enhance the power systems concentration in an Electrical Engineering program is presented. The aim of this course is to introduce students to contemporary topics related to distributed generation, micro-grids, renewable energy sources, and smart homes applications. This proposed 4-credit course is designed to provide students with a working knowledge from the basic concepts of power systems to the inherent elements of computational intelligence including decision support systems, smart metering, cyber security, optimization, and renewable energy sources. The automation and computational techniques involved in Smart Grid technologies are also introduced with special emphasis on the interoperability of different renewable energy sources without losing the integrity and reliability of the existing power systems. Furthermore, the standards and requirements for designing new devices and products for Smart Grid applications are introduced and discussed in this course. Topics in power generation, transmission, distribution, demand response, and reconfiguration are thoughtfully explained with real world applications to enhance the student learning process. Several case studies are analyzed and simulated using software tools such as MATLAB, Simulink, and PowerWorld packages. The course has also a laboratory component which provides students with hand-on experience in the utilization of commonly used tools to formulate and solve engineering problems.

Keywords

Smart Grid, Course, Power systems, Smart metering

Introduction

Traditionally, the operational objectives of electric utilities have been to provide reliable energy at minimum cost which can be stated as: 1) to supply quality power at constant voltage and frequency; 2) to minimize adverse effects on people and the environment; 3) to maintain adequate system security and reliability; and 4) minimize energy loss¹. Recent technological advances in small generators, power electronics, and energy storage devices have provided new opportunities at the distribution level. These advancements resulted in numerous economic incentives to decentralize and help expand the existing power systems. In the near future, Smart Grid (SG) technologies will play a central role in social and economic development at all scales. Furthermore, energy production is usually associated with environmental pollution and SG technologies will help to alleviate this problem by integrating more renewable energy sources into the power grid. Green energy sources such as fuel cells, micro-turbines, PV generating stations, and wind farms can be connected using SG technologies¹⁻⁶. Today's advancements in SG technologies have increased interest among the new generation of engineers and therefore

provided an opportunity to train students in these developing technologies. In this paper, a new course in SG technologies is proposed to strengthen the concentration area in power systems in the Electrical Engineering (EE) department at Georgia Southern University (GSU). Knowledge from the basic concepts of power systems to the inherent elements of computational intelligence including decision support systems, smart metering, cyber security, optimization, and renewable energy sources are discussed. In addition, computational techniques used in SG technologies are presented to enhance students' ability to design and analyze SG systems. Topics in distributed power generation and computer simulation are presented. The course has also a laboratory component which provided students with hand-on experience in the utilization of commonly used tools to formulate and solve engineering problems. The course goals and educational objectives that conform to an engineering program are also presented.

Smart Grid Systems

Smart Grid energy systems are rapidly gaining popularity, particularly onsite generation or what is referred to as distributed generation. The reason driving this move is the high running cost of large power plants due to high fuel costs, and more strict environmental regulations. In addition, recent technological advances in distributed energy resources are increasing the feasibility of renewable energy integration into the grid. Many governments are providing incentives to promote the utilization of renewable energies, which encourages a more decentralized approach to power delivery systems^{2,4,5}. Figure 1 illustrates a smart grid system.

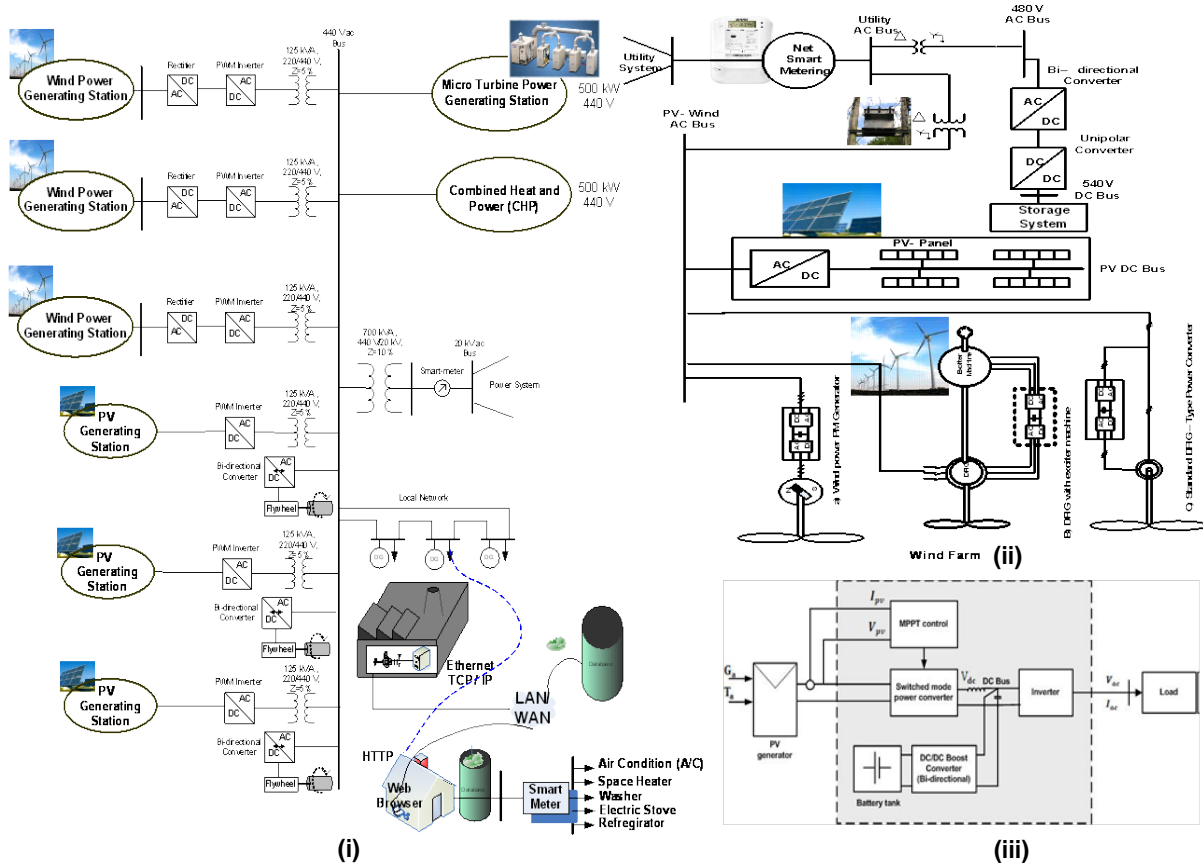

Figure 1- (i) Smart Grid System; (ii), PV and Wind Hybrid System; (iii) Stand-alone PV system.

Learning about SG technologies is important since it has the potential to be the next generation power grid at every level, from household and community to regional, national and international. Another motivation to incorporate renewable energy sources within the distributed generation is the environmental cleanness of these sources. These types of energy sources will eventually replace all the nonrenewable fossil fuels sources that cause pollution and climate change. Because of these problems, and the shortage of the petroleum supply, finding sustainable alternatives is becoming increasingly urgent. Therefore, developing technologies to efficiently integrate sustainable sources into the grid is a challenging task. The development of distributed energy system technology will empower the end energy users to participate in energy production, energy utilization and reduction of waste. The most important development is the impact of energy production on environment. Distributed energy system will no longer leave the end energy users totally dependent on a central power station. Therefore, the main reason for developing this course is to help students learn more about these new topics and better prepare them for the future power grid.

In power systems, the main objective is to provide continuous service and reliable electricity at affordable cost which in technical terms can be stated as follows: 1) to supply quality power at constant voltage and frequency; 2) to generate power within pollution limits set by environmental regulations; 3) to provide adequate system security and reliability; and 5) to meet load or customer demand at the lowest possible cost. The term “continuous service” can be translated to mean “secure and reliable service”. Secure service means that upon occurrence of a contingency the system will be able to recover to its previous state and reliability is the ability of the system to supply power as the load changes. The interrelationship between those various objectives has been defined as shown in Figure 2. The direction of the arrows indicates the priority in which the objectives are implemented. The dotted line indicates that if the operation of the system violates the environmental constraints, then the operation of the system may have to be altered or curtailed^{2,4}.

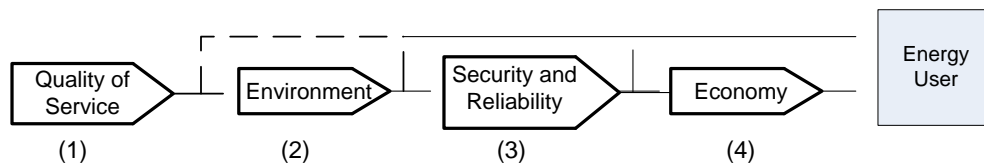

Figure 2- Interrelated Objectives of Operation of a Typical Power System

In smart grid applications, the information flow between the different parts is controlled by an energy management system (EMS) which communicates with individual smart meters located at residential, commercial, and industrial customer sites. As shown in Figure 3, smart meters are installed to control loads using a set of Ethernet TCP/IP sensors, transducers, and communication protocol. Moreover, in microgrids large interconnected systems and smart meters are designed to provide intelligent grid optimization that would allow control of various customer loads based on pricing signals and grid stress. In general, smart meters will control devices at the customer location to shed load or allow distributed generation to be connected on-line as part of an optimal power dispatch scheme.

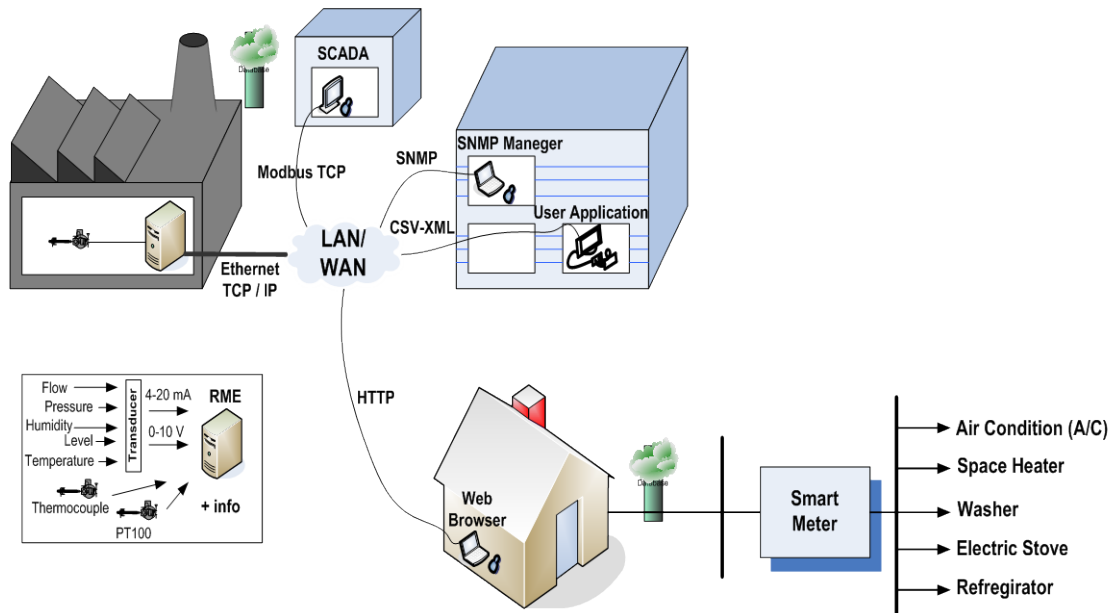

Figure 3- Smart Sensors, Transducers, and Communication Protocol for Load Control

In micro grids systems, renewable sources, such as PV generating stations and wind farms, are interconnected via a common DC bus using DC/DC converters. To reduce power losses, system components including inverters, storage units, transformers, and net metering are all located in the DG station^{2,3}. Another area of development is smart house technology which can provide safety, security, and ease of self-management for people with disabilities. For instance, smart house technology is extremely useful for monitoring individuals with Alzheimer disease allowing them to live at home with their family⁷.

Course Descriptions

The proposed course in smart grid technology is intended to be offered at the senior level as an undergraduate EE elective which can also be dual-offered with the graduate level. This 4-credit hour course is designed to be taught as a 3-hours lectures and 2-hours laboratory component per week. Students taking this course must have an introductory course in Power Systems as pre-requisites. Since topics are covered from various sources, students are not required to use a textbook but rather a set of six references 1-6 and research publications. Topics covered will provide students with a working knowledge of SG technologies and their applications. In addition, students are expected to develop expertise in the design, modeling, control, analysis, and development of Smart Grid. Laboratory experimentations are based on the utilization of computing software tools and physical experimentation Laboratory equipment. The educational objectives of this course will enable students to:

- Explain the fundamental elements of SG technologies.
- Describe the fundamental structure of the micro- grid and distributed generation concept.
- Use simulation tools such as MATLAB and Paladin for power analysis and optimization.
- Describe the communication systems, networking, and sensing technologies involved.
- Perform computational techniques using decision support tools and optimization.
- Understand various DP sources including working concepts and modeling.

2015 ASEE Southeast Section Conference

- Understand standards interoperability and cyber security.
- Design and analyze systems involving smart grid and DP sources.

The laboratory instructions for the course are based on the utilization of computing software tools commonly used by power Engineers such as MATLAB, Simulink, tool-boxes, PowerSim Matlab library, PowerWorld, in addition to using the Lab-Volt equipment. Topics covered are organized on a weekly basis as follow:

- **Week 1:** Introduction to smart-grid and power-grid operation.
- **Week 2 - 3:** Elements of SG and measurement technologies: generation, transmission, distribution, and end user; basic concepts of power, load models, power flow analysis wide area monitoring system (WAMS), advanced metering infrastructure (AMI), and phasor measurement units (PMU); introduction to simulation tools.
- **Week 4 - 5:** Elements of communication and networking: architectures, standards and adaptation of power line communication, Global System for Mobile Communications (GSM) and more; machine-to-machine communication models for SG; home area networks (HAN) and neighborhood area networks (NAN); reliability, redundancy and security aspects.
- **Week 6 - 7:** Elements of networks and data analysis, introduction to state estimation; detection and identification of bad data; real-time network modeling; dynamic state estimation under SG environment.
- **Week 8 - 9:** Elements of computation and decision support tools: classical optimization methods, evolutionary computational techniques (genetic algorithms, particle swarm and ant colony optimization).
- **Week 10 - 11:** Elements of distributed energy resources (DER) and grid integration: renewable energy, energy storage; solar energy, wind energy, biomass, hydropower, geothermal and fuel cell; effect of electric vehicles (EVs).
- **Week 12 - 13:** Elements of energy management; Supervisory Control and Data Acquisition (SCADA); micro-grids; demonstration projects; case studies.
- **Week 14:** Policy and economic drives of SG systems; environmental implications; sustainability issues; state of SG implementation.
- **Week 15:** Review and Final Examination.

Part of the course will be supported by experimentations that will be conducted using computer simulation and experimental laboratories. Lab topics are:

- Microgrids and distributed generation sources (such as microturbines, reciprocating engines, wind generators, photovoltaic generators, fuel cells, and other technologies)

modeling using simulation tools such as: MATLAB, Power Systems toolbox, Simulink, PowerWorld and Labview.

- Energy Storage Modeling like: batteries, fly-wheels, ultra-capacitors, and other technologies.
- Power electronics interfaces simulation like: multiple and single input DC-DC converters, AC-DC and DC-AC.
- Smart Grids communications and smart house automation simulations.
- Power architectures simulation: distributed or centralized DC and AC distribution systems.
- Smart grid Stability, Faults analysis, control and protections simulation using MATLAB toolboxes, SCADA and PowerWorld software.
- Grid economics estimations (such as Statistical and ANN software) and optimization (Generic Algorithm and Particle Swarm).
- Microgrid interconnection issues simulation like: Reliability, availability and planning.
- Experimental AC/DC Control using Lab-Volt devices: Electronic conversion systems application to renewable energy generation systems, and Wind Power and Photovoltaic Power applications.
- Experimental applications and power system simulation using PSCAD, Power Systems Toolbox and Lab-Volts facilities: Modeling of thyristor-based static Var compensator, Modeling of GTO-Based, Modeling of VSC, Based HVDC Link, and Modeling and performance of SSCC in wind energy application.
- Experimental Electric Systems modeling and systems implementations using Lab-Volts devices: Steady state simulation studies, Load flux, Short-circuit, Electric systems modeling for permanent regime studies, electric systems modeling for simulation in dynamic state, transient state electric systems modeling, line modeling, generation systems modeling and storage devices modeling.

Total students' grade in the course will be based on two exams (15% each) to assess the students understanding level after certain milestones during the semester, a final research project (15%) to test the students understanding of recent advancement in smart-grid applications, a (5%) credit for attendance and participation, weekly Lab projects (20%), and a Final comprehensive exam (30%).

Conclusions

In this paper, a new course in smart-grid technologies is presented. This course is designed to introduce students to new topics related to distributed generation, micro-grids, renewable energy sources, and smart homes applications that are being introduced into the power sector. Topics covered include design, modeling, control, and analysis will provide students with working knowledge of smart-grid systems. Furthermore, concepts dealing with computational intelligence, communication technology, decision support systems, smart metering, cyber security, optimization, and renewable energy sources will be presented. The automation and computational techniques used to ensure smart-grid will also be introduced and discussed. The laboratory component associated with this course will provide students with the hand-on experience in the utilization of smart-grid technologies and equipment. Students completing this course will not only be able to provide solution to real-world energy problems but also to

understand the impact of smart-grid applications in security, entertainment, and the healthcare industry.

References

- 1 D. Mah, P. Hills, Li, V.O.K., Balme, R. (Eds.), "Smart Grid Applications and Developments", Series: Green Energy and Technology, Springer-Verlag Berlin Heidelberg, 2014.
- 2 A. Keyhani, M. Marwali, (Eds.), "Smart power Grids 2011 Book", Series: Power Systems, Springer-Verlag Berlin Heidelberg 2012.
- 3 J. Momoh, "Smart Grid Fundamentals of Design and Analysis," Wiley, 2012.
- 4 A. Keyhani, "Smart Power Grid Renewable Energy Systems," Wiley 2011.
- 5 A. Keyhani, "Integration of Green and Renewable Energy in Electric Power Systems," Wiley, 2010.
- 6 A. El-Shahat, "Artificial Neural Network (ANN): Smart & Energy Systems Applications", Scholar Press Publishing, 2014.
- 7 Internet Home Alliance. Research Review, Topic: "State of the Connected Home Market Study 2008." Continental Automated Buildings Association, Ottawa, Ontario, Canada, 2008.

Adel El-Shahat

Adel El Shahat is currently an Assistant Professor, RLT of Electrical Engineering in the Department of Electrical Engineering at Georgia Southern University. He received his B.Sc. in Electrical Engineering from Zagazig University, Zagazig, Egypt, in 1999. He received his M.Sc. in Electrical Engineering (Power & Machines) from Zagazig University, Zagazig, Egypt in 2004. He received his Ph.D. degree (Joint Supervision) from Zagazig University, Zagazig, Egypt, and The Ohio State University (OSU), Columbus, OH, USA, in 2011. His research focuses on various aspects of Power Systems, Smart Grid Systems, Power Electronics, Electric Machines, Renewable Energy Systems, Energy Storage, and Engineering Education.

Rami J. Haddad

Rami J. Haddad is an Assistant Professor in the Department of Electrical Engineering at Georgia Southern University. He received his B.S. degree in Electronics and Telecommunication Engineering from the Applied Sciences University, Amman, Jordan, his M.S. degree in Electrical and Computer Engineering from the University of Minnesota, Duluth, MN, and his Ph.D. degree from the University of Akron, Akron, OH. His research focuses on various aspects of optical fiber communication/networks, broadband networks, smart grid applications, multimedia bandwidth forecasting and engineering education.

Youakim Kalaani

Youakim Kalaani is an Associate Professor of Electrical Engineering in the Department of Electrical Engineering at Georgia Southern University. Dr. Kalaani received his B.S. degree in Electrical Engineering from Cleveland State University (CSU). He graduated from CSU with M.S. and Doctoral degrees in Electrical Engineering with concentration in power systems. Dr. Kalaani is a licensed professional engineer (PE) and an ABET Program Evaluator (PA). He is a member of IEEE and has research interests in distributed power generations, optimization, and engineering education.