

12 Mar 1991, 10:30 am - 12:00 pm

## In Situ Torsional Cylindrical Shear Test-Laboratory Results

W. Henke

*Dynamic In Situ Geotechnical Testing, Inc., MD*

R. Henke

*Dynamic In Situ Geotechnical Testing, Inc., MD*

Follow this and additional works at: <https://scholarsmine.mst.edu/icrageesd>



Part of the [Geotechnical Engineering Commons](#)

### Recommended Citation

Henke, W. and Henke, R., "In Situ Torsional Cylindrical Shear Test-Laboratory Results" (1991). *International Conferences on Recent Advances in Geotechnical Earthquake Engineering and Soil Dynamics*. 25.  
<https://scholarsmine.mst.edu/icrageesd/02icrageesd/session01/25>

This Article - Conference proceedings is brought to you for free and open access by Scholars' Mine. It has been accepted for inclusion in International Conferences on Recent Advances in Geotechnical Earthquake Engineering and Soil Dynamics by an authorized administrator of Scholars' Mine. This work is protected by U. S. Copyright Law. Unauthorized use including reproduction for redistribution requires the permission of the copyright holder. For more information, please contact [scholarsmine@mst.edu](mailto:scholarsmine@mst.edu).



# In Situ Torsional Cylindrical Shear Test-Laboratory Results

W. Henke

President, Dynamic In Situ Geotechnical Testing, Inc.

R. Henke

Technical Advisor, Dynamic In Situ Geotechnical Testing, Inc.

**SYNOPSIS:** We present results from cyclic tests conducted in the laboratory using a prototype in situ cyclic torsional cylindrical shear geotechnical testing system. The system is intended to advance our ability to design critical systems to resist earthquakes by improving our ability to analytically predict the behavior of soil-structure-equipment systems during earthquakes. It is to do so by providing, more reliably than we feel is now possible, estimates of the in situ cyclic shear stress vs strain characteristics needed by refined earthquake analyses. These characteristics include 1) resistances to initial liquefaction, cyclic degradation, and large cyclic deformations, and 2) undegraded, nonlinear, inelastic characteristics. The testing system was found to be effective under representative controlled laboratory conditions and promising for field use. Test results were found to be reasonable and consistent with published results of laboratory tests of a high quality. Additionally, we did not observe major limitations or encounter abnormal difficulties.

## INTRODUCTION

We present and discuss results from cyclic tests conducted in the laboratory using a prototype in situ torsional cylindrical shear geotechnical testing system (Henke and Henke, 1987; Henke and Henke, 1985; Henke and Henke, 1990). The system is intended to advance our ability to design critical systems to resist earthquakes. The testing system was found to be effective under controlled laboratory conditions and promising for field use. In the following sections we present the proposed testing procedure, the objective of our testing program, test equipment and procedures, test results, conclusions, acknowledgments, and references.

## PROPOSED TESTING PROCEDURE

The in situ cyclic torsional cylindrical shear test is intended to advance our ability to analytically predict the behavior of soil deposits during earthquakes. It is to do so by providing, more reliably than we feel is now possible, estimates of the in situ cyclic shear stress vs strain characteristics needed by refined earthquake analyses. These characteristics include 1) resistances to initial liquefaction, cyclic degradation, and large deformations before and after initial liquefaction, and 2) undegraded, nonlinear, inelastic characteristics. The information to be provided is to be suitable for the advanced stages of the earthquake resistant design of critical systems.

The proposed testing procedure effectively combines attractive features of existing procedures while minimizing shortcomings. As in laboratory tests, earthquake-like cyclic shearing loads are applied to an element of soil. Cyclic shearing behavior expected during

earthquakes is induced. Detailed information is provided. Tests, however, are conducted in situ. Thus, the important effects of in situ conditions are expected to be well-preserved.

Figure 1 shows, schematically, some of the main elements of the probe of the prototype testing system. Basically, two concentric, thin-walled cylinders are carefully penetrated below the base of a borehole. The test soil is the well-defined annular zone of soil between the two cylinders. During our testing program we also tested a version of the probe consisting of only the inner cylinder. A cyclic torque is applied to the active (inner or single) cylinder to induce earthquake-like shear stresses and strains in the test soil. Both torque,  $T$ , and rotation,  $\theta$ , are measured by transducers in the instrumented head. Soil characteristics are inferred by iteratively simulating tests analytically.

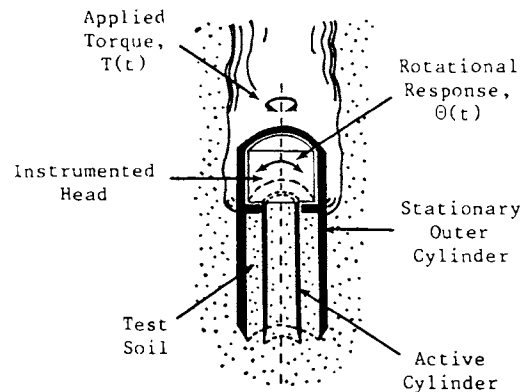

Figure 1: Main Elements of Probe (Without Casing)

The proposed testing procedure offers several important features. Also, several steps are taken to preserve in situ conditions and to improve operability.

Prior to testing, a special casing is penetrated below the base of the borehole. The casing helps preserve the original state of stress and reduce effects of drilling. The casing is shown schematically in Figure 2. Before testing, the casing is carefully cleaned out and the soil at the base is carefully trimmed.

The probe includes an annular piston, shown in Figures 2 and 3. The piston can move longitudinally and applies an appropriate vertical pressure to the test soil. Prior to penetration, the piston is moved to the end of the probe and pressurized. Upon application of penetration force to the probe, the cylinders advance relative to the piston into the test soil. This procedure of penetrating under pressure is expected to help reduce particle movement during penetration and preserve the original in situ state of stress.

During a test, the piston is operated in one of two modes: the constant volume mode or the constant pressure mode. We discuss only the constant volume mode since all tests discussed herein were conducted in this mode. In the constant volume mode, the piston and the probe are locked into vertical position immediately prior to a test. Thus, a condition of relatively constant volume is maintained in the region of the test soil. The volume does not remain completely constant mainly because of soil compressibility.

The constant volume mode allows us to induce, without buildups in porewater pressure, phenomena corresponding to those caused by earthquake-like cyclic loading under saturated undrained conditions (Finn, et al., 1982). These phenomena include degradation and initial liquefaction due to densification, restiffening due to dilation, and large deformations before and after initial liquefaction (including limited strains). Basically, these are caused by changes in effective confining pressure. Such changes occur under conditions of overall constant volume due to the combined tendencies for densification, rebound, and dilation of grain structure caused by cyclic shearing loads.

The proposed testing procedure offers other important features. The inner and outer cylinders have thin walls to avoid excessive disturbances. As shown in Figure 3, the penetrating edges of the cylinders are shaped to minimize disturbances to the test soil during penetration. The surfaces of the cylinders may be grooved longitudinally to reduce slip during testing while minimizing disturbances during penetration. The cylinders may be polished or coated with a low friction material, depending on the soil type, to further reduce disturbances during penetration. We also include features to minimize the influence of the soil within the active cylinder on its motion. The inner wall of the cylinder is smooth and may be coated with a low friction material, soil is diverted away from the inner wall by jugged penetrating edges, and confining pressures on the soil within the active cylinder are minimized by providing

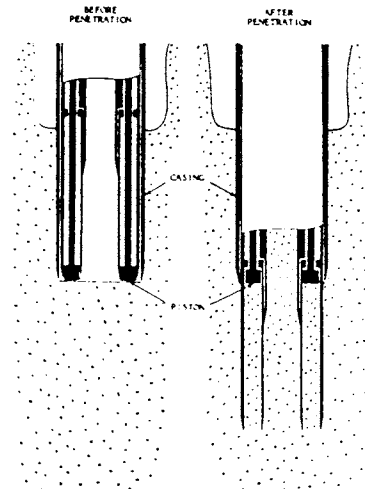

Figure 2: Operation of Piston System

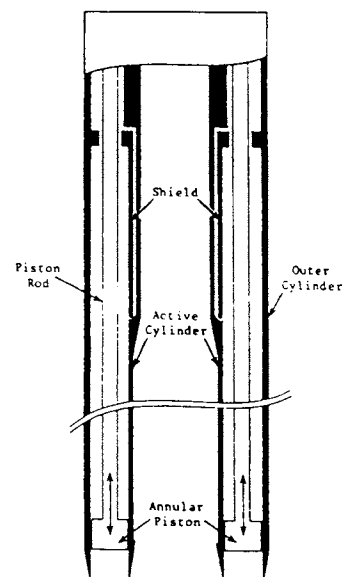

Figure 3: Features of Probe

excess volume. The upper portion of the active cylinder is shielded, as shown in Figure 3; thus, the test soil is located some distance below the bottom of the casing. This reduces effects of unloading and trimming.

#### OBJECTIVE OF TESTING PROGRAM

The main objective of our testing program was to evaluate the effectiveness of the proposed testing procedure under representative controlled laboratory conditions. For this we conducted laboratory tests of a high quality using a laboratory research prototype testing system. If test results were found to be reasonable, interpretable, and consistent with

published results of laboratory cyclic tests of a high quality and if we did not observe major limitations or encounter abnormal difficulties then we would conclude that 1) the proposed procedure is an effective means for estimating cyclic soil characteristics under controlled laboratory conditions and 2) the proposed procedure is promising for field use.

#### TEST EQUIPMENT AND PROCEDURES

Our main pieces of test equipment were the prototype testing system and a large laboratory test chamber designed for testing the system in large uniform samples of sand subjected to representative confining pressures. The sample of sand was 4 ft in diameter and 2.67 ft high. The test chamber and the probe of the prototype testing system are shown in Figure 4.



Figure 4: Test Equipment

The test sand was deposited uniformly in layers by raining from a hopper/roller system which traveled at a constant speed over the chamber. A platform within the chamber was raised to the top of the chamber. Several layers of sand were rained onto the platform. The platform was then carefully lowered by the amount deposited and several more layers were deposited. This process was repeated until the chamber was filled. Thus, the height of fall, which can strongly affect the relative density,  $D_r$ , of a sample, remained reasonably constant. This process provided good repeatability.

After deposition, we applied representative confining pressures to the sample using pressure bags. Lateral pressure was applied by a bag surrounding the sample. Vertical pressure was applied by a bag located on the top of the

sample. The pressure in each bag was independently controlled.

To prepare for a test, a special thin-walled casing was carefully penetrated into the sample. The casing was cleaned out and the soil at the bottom of the casing was carefully trimmed. The probe was penetrated slowly (0.04 cm/sec) into the sample. After penetration, we waited a short period of time before conducting tests to allow grains to readjust.

We tested the prototype system under conditions for which the proposed testing procedure is expected to be of greatest value. Tests were conducted on samples of dry ottawa sand with a distribution of grain sizes that falls within the bounds for the most liquefiable soils (Committee on Earthquake Engineering, et al., 1985). We prepared samples for most tests to medium dense relative densities. Deposits of medium dense sands are common borderline cases. They present the greatest uncertainty in estimating behavior, which can apparently vary greatly. A representative confining pressure of 10 psi (lateral pressure = vertical pressure) was applied to each test sample. This pressure corresponds roughly to the effective confining pressure at a depth of 35 ft in a deposit of normally consolidated, saturated sand. This depth is representative of the shallow depths at which liquefaction generally takes place (Seed, 1976).

Cyclic tests were conducted in the constant volume mode to bring out, in the dry sand, the main effects of cyclic loading under saturated, undrained conditions. We applied a sinusoidal torque of preselected constant amplitude to the active cylinder at a frequency of 1 cps. This frequency is representative of frequencies observed in soil deposits during earthquakes. The applied torque and the angular displacement of the instrumented head were measured. Analog data was displayed on a storage oscilloscope and photographed. Digitized data was also recorded.

#### TEST RESULTS

We present and discuss results from formal tests and informal practice tests conducted using the double cylinder probe. Comparable results were obtained using the single cylinder probe (Henke and Henke, 1990).

##### Formal Cyclic Tests

Results from a series of three formal cyclic tests conducted using the double cylinder probe were found to be reasonable, interpretable, and consistent with published results from comparable laboratory cyclic tests of a high quality conducted on undrained, saturated samples of sand (Committee on Earthquake Engineering, et al., 1985). We did not encounter limitations or abnormal difficulties. The average relative density of the test samples for these tests was 58.1%. The active cylinder was grooved and uncoated, and the outer cylinder was smooth and uncoated.

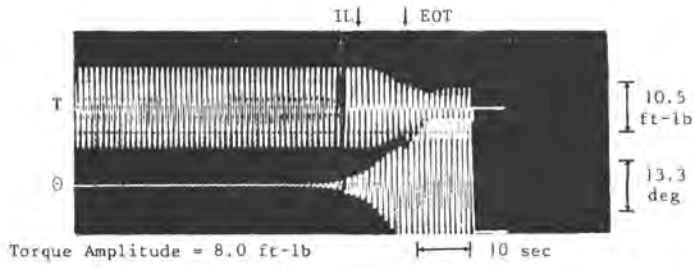

(a) Representative Photographs of Oscilloscope Face

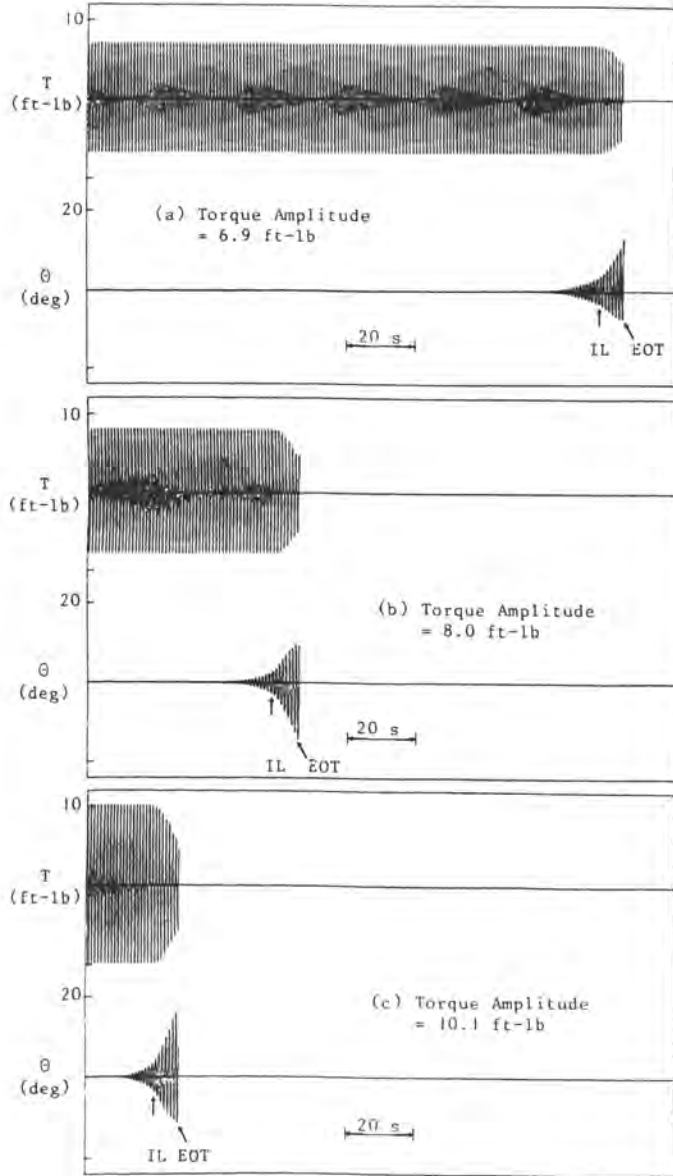

(b) Digitized Traces

Figure 5: Test Results. Average  $D_r = 58.1\%$ .  
 EOT = End of Test due to Striking of Stops.  
 IL = Initial Liquefaction ( $\Delta T/\Delta\theta \approx 0$ ).

Selected results are presented in Figures 5, 6, and 7. The traces of the angular displacement of the instrumented head vs time shown in Figure 5 show an intermediate level of degradation. For each test, the amplitude of the angular displacement increases, at an intermediate rate, to a relatively high level with an increase in the number of cycles of loading. Without the probe's mechanical stops, it seems this amplitude would have reached a limited value due to dilation. Also, the representative torque vs angular displacement curve presented in Figure 6(a) shows nonlinearity, inelasticity, cyclic degradation, behavior corresponding to "initial liquefaction" due to densification, and restiffening due to dilation. The representative curve presented in Figure 6(b) shows the identification of the cycle in which "initial liquefaction" (for prototype, first instance for which torsional stiffness almost zero,  $\Delta T/\Delta\theta \approx 0$ ) occurred. This curve is comparable to corresponding published curves (Committee on Earthquake Engineering, et al., 1985). Figure 7 presents a liquefaction curve. The number of cycles to initial liquefaction decreases as the amplitude of the cyclic torque increases. This curve is consistent with liquefaction curves presented in the literature (Committee on Earthquake Engineering, et al., 1985) for laboratory cyclic tests. This consistency suggests repeatability of test results.

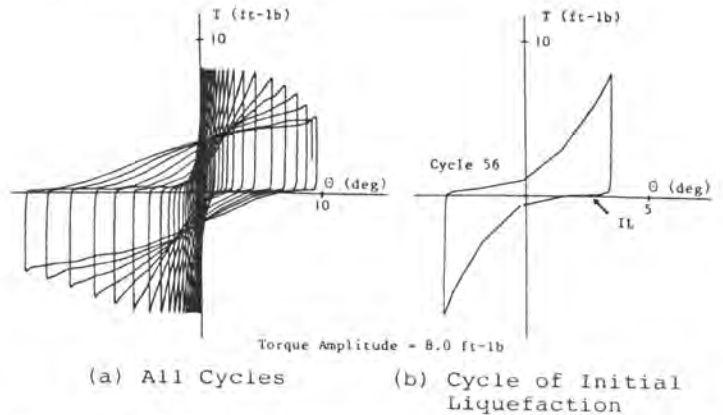

Figure 6: Representative Test Results - Digitized Curves. IL = Initial Liquefaction ( $\Delta T/\Delta\theta \approx 0$ ).

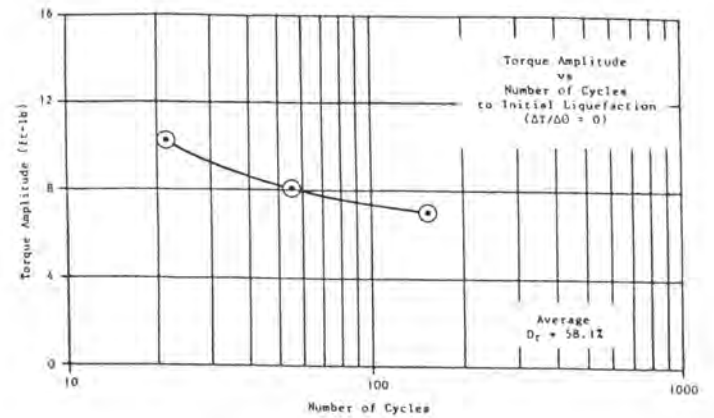

Figure 7: Test Results

Some difficulties were encountered during testing but we feel these are neither abnormal nor insurmountable. We experienced difficulties in measuring accurately the small angular displacements developed during early cycles of loading. Also, we experienced some difficulty with the piston system; the piston did not retract entirely during penetration. These difficulties did not occur with the single cylinder probe. We feel we will be able to overcome these difficulties with further engineering.

#### Practice Cyclic Tests

We present results from selected practice tests. These were conducted informally in preparation for the formal tests discussed above. The practice tests demonstrate behavior not brought out by the formal tests. Results are reasonable, interpretable, and consistent with published results obtained from laboratory cyclic tests of a high quality conducted on saturated, undrained sands (Committee on Earthquake Engineering, et al., 1985).

Results, shown in Figure 8, from one practice test are consistent with the behavior of dense sands (Committee on Earthquake Engineering, et al., 1985). Our results are for a test conducted on a sample having a relative density of 65.2%. Both cylinders were coated and grooved. The curve of the angular displacement of the instrumented head vs time shows degradation. The amplitude of the angular displacement gradually increases with an increase in the number of cycles of loading. Additionally, this amplitude reaches a limited value due to dilation. The torque vs angular displacement curve also shows the development of limited angular displacements.

Results, shown in Figure 9, from a second practice test are consistent with the behavior of loose sands (Committee on Earthquake Engineering, et al., 1985). The relative density of our sample is unknown but was probably low considering the manner in which the soil was deposited. The active cylinder was uncoated and grooved. The outer cylinder was uncoated and smooth. The curve of angular displacement vs time shows a period of mild degradation followed by a sudden large increase in the amplitude of the angular displacement. This sudden increase is interpreted as the onset of liquefaction. No other information was obtained.

#### CONCLUSIONS

The in situ cyclic torsional cylindrical shear test is a promising means for estimating reliably in situ cyclic shear stress vs strain characteristics of soil deposits. These characteristics include 1) resistances to initial liquefaction, degradation, and large deformations before and after initial liquefaction, and 2) undegraded, nonlinear, inelastic characteristics. Estimates of characteristics are expected to be appropriate for use at the advanced stages of the earthquake resistant design of critical systems.

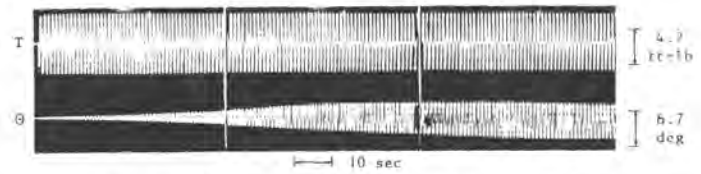

(a) Photographs of Oscilloscope Face

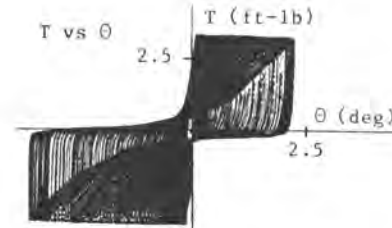

(b) Digitized Curve

Figure 8: Results from Practice Cyclic Test.  
 $D_r = 65.2\%$ .

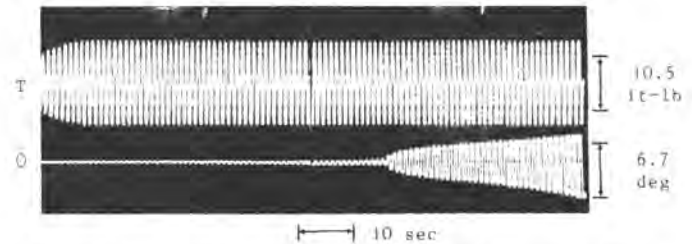

Figure 9: Results from Practice Cyclic Test -  
Photographs of Oscilloscope Face.  
 $D_r$  Unknown but Probably Low.

The in situ cyclic torsional cylindrical shear test was found to be effective under representative controlled laboratory conditions. Results from cyclic tests were found to be reasonable, interpretable, and consistent with published results from laboratory cyclic tests of a high quality and were judged to be repeatable. Cyclic tests were found to bring out important aspects of cyclic shear stress vs strain characteristics of cohesionless soils. These aspects include initial liquefaction, deformations before and after initial liquefaction including limited strains, and undegraded, nonlinear, inelastic characteristics. No abnormal difficulties or major limitations were encountered.

#### ACKNOWLEDGMENTS

The material presented herein is based upon work supported by the National Science Foundation under the Small Business Innovation Research Program (award numbers ISI-8601419 and CEE-8460719). The Department of Energy, through the Energy-Related Inventions Program, supported the construction of the laboratory prototype testing system described herein (grant number DE-FG01-87CE15305). The efforts of the National Institute of Standards and Technology toward the development of the testing system are also gratefully acknowledged.

## REFERENCES

- Committee on Earthquake Engineering, Commission on Engineering and Technical Systems, and the National Research Council (1985), "Liquefaction of Soils During Earthquakes," Report for the National Science Foundation, National Academy Press, Washington, D.C.
- Finn, W.D.L., Bhatia, S.K., and Pickering, D.J. (1982), "The Cyclic Simple Shear Test," Soil Mechanics-Transient and Cyclic Loads, John Wiley and Sons, New York, 583-607.
- Henke, R. and Henke, W. (1987), "Laboratory Prototype of In Situ Cyclic and Dynamic Geotechnical Testing System," Soil Dynamics and Liquefaction, Proceedings, 3rd International Conference on Soil Dynamics and Earthquake Engineering, Princeton University, Princeton, New Jersey, June 22-24, 299-305.
- Henke, R. and Henke, W. (1985), "In Situ Testing Method for Obtaining Cyclic and Dynamic Soil Properties," Soil Dynamics and Earthquake Engineering, Proceedings, 2nd International Conference on Soil Dynamics and Earthquake Engineering, on board the ocean liner Queen Elizabeth 2, sailing from New York to Southampton, June/July, 2-47 to 2-56.
- Henke, W. and Henke, R. (1990), "In Situ Testing Procedure for Obtaining Dynamic and Cyclic Soil Properties," Small Business Innovation Research Phase II Report prepared for the National Science Foundation by Dynamic In Situ Geotechnical Testing, Inc., Lutherville, MD, March.
- Seed, H.B. (1976), "Evaluation of Soil Liquefaction Effects on Level Ground During Earthquakes," State-of-the-Art Paper, Liquefaction Problems in Geotechnical Engineering, Preprint 2752, ASCE Annual Convention, Sept. 27-Oct. 1, Philadelphia, PA, 1-104.