



Missouri University of Science and Technology
Scholars' Mine

International Conferences on Recent Advances
in Geotechnical Earthquake Engineering and
Soil Dynamics

1991 - Second International Conference on
Recent Advances in Geotechnical Earthquake
Engineering & Soil Dynamics

11 Mar 1991, 9:30 am - 10:30 am

Field and Laboratory Determination of Soil Properties at Low and High Strains

R. D. Woods

University of Michigan, Ann Arbor, MI

Follow this and additional works at: <https://scholarsmine.mst.edu/icrageesd>



Part of the [Geotechnical Engineering Commons](#)

Recommended Citation

Woods, R. D., "Field and Laboratory Determination of Soil Properties at Low and High Strains" (1991). *International Conferences on Recent Advances in Geotechnical Earthquake Engineering and Soil Dynamics*. 9.

<https://scholarsmine.mst.edu/icrageesd/02icrageesd/session14/9>

This Article - Conference proceedings is brought to you for free and open access by Scholars' Mine. It has been accepted for inclusion in International Conferences on Recent Advances in Geotechnical Earthquake Engineering and Soil Dynamics by an authorized administrator of Scholars' Mine. This work is protected by U. S. Copyright Law. Unauthorized use including reproduction for redistribution requires the permission of the copyright holder. For more information, please contact scholarsmine@mst.edu.



Field and Laboratory Determination of Soil Properties at Low and High Strains

(State of the Art Paper)

R.D. Woods

Professor, Department of Civil Engineering, University of Michigan, Ann Arbor, MI 48109-2125

SYNOPSIS Over the past quarter century many testing methods have been used to determine soil properties for dynamic analysis. Most methods had been established by the time of the writer's review (Woods, 1978), and since then, changes have been mostly evolutionary. Many field and laboratory techniques are represented in papers submitted to this conference and these are reviewed, but additional citations from literature in the intervening years has been included for completeness. No claim is made that all pertinent literature is included, but that most methods of field and laboratory testing methods are covered with representative citations.

INTRODUCTION

Since the First International Conference on Recent Advances in Geotechnical Earthquake Engineering and Soil Dynamics, April-May, 1981, there have been many changes in the way that soil properties are obtained for dynamic and earthquake analyses. Few of these changes could be considered even remotely revolutionary while all are in some way evolutionary.

Most of the elements of all commonly used laboratory and field tests were incorporated in the writers state-of-the-art paper (Woods 1978). However, several important advances have been made in terms of refinements and sophistication in equipment and in interpretation of the results. In some cases analytical methods have been the cause of changes in testing methods, while in other cases, improved testing techniques have made more accurate analysis possible.

There seems to be no better way to present the laboratory and field testing techniques than to consider them separately, although in practice it is often desirable and even necessary to compare and couple results.

However, one matter which involves all soil testing should be considered first. The geotechnical engineering community has come a long way in their ability to measure soil and rock properties which are needed in dynamic analyses, but geotechnical engineers have developed a habit of calling the properties required and measured "dynamic properties." In the writers opinion, it is time to drop the modifier "dynamic", because the properties to which we refer simply categorize the properties based on "strain amplitude." It has been recognized for decades that the stress-strain behavior of soils is non-linear from very small strains whether the strains come from static or dynamic phenomena, so what we really need to describe is the strain amplitude regime. We have already

found a widely accepted symbol to describe shear modulus for very low strain, G_0 , and a way to describe the changes that take place as a function of strain by using the modulus ratio, G/G_0 .

There are many applications in geotechnical engineering of low strain properties which have nothing to do with "dynamics", and the applications of a broad variety of existing measurement techniques to these problems would be a benefit to the entire profession. It is the writer's hope that the mystique associated with "dynamic" properties can be set aside with full understanding of the usefulness of the same properties in all geotechnical problems.

Cyclic behavior of soils is a separate classification of behavior for which the "cyclic" modifier should be preserved. One salient feature of liquefaction behavior is that associated with the "cyclic" nature of ground shaking, and its cumulative consequences. This must not be ignored. But static cycling of large stresses in soils by other loading mechanisms should also be treated as cyclic in testing and analysis, and nomenclature. "Cyclic" also should not be equated exclusively with dynamic phenomena.

SIGNIFICANT MEETINGS WITH PROCEEDINGS

Since 1981, there have been several technical meetings devoted to topics for which there was a component of laboratory and field measurement of soil properties over a wide range of strain. Some of these have been associated with earthquake problems while others have been of a more general nature. Below are listed some of the meetings for which published proceedings are available and which had a component associated with the topics to be discussed here. It is not intended that this is an exhaustive list, but rather one which has grown out of the writer's literature search, and one which gives representative publications on the topics of interest here.

There are also, of course, many regular publications in which investigators publish their works and these are too numerous to list independently, but these are well represented in the reference list accompanying this review.

A) American Society of Civil Engineers (ASCE)

Specialty conference:

"Earthquake Engineering and Soil Dynamics II, Recent Advances in Ground-Motion Evaluation", Proceedings of the specialty conference sponsored by the Geotechnical Engineering Division, ASCE, Park City, Utah, June 27-30, 1988, Geotechnical Special Publication No. 20, Edited by J.L. Von Thun.

Convention Sessions:

"Measurement and Use of Shear Wave Velocity for Evaluating Dynamic Properties", Proceedings of a session sponsored by the Geotechnical Engineering Division, ASCE, in conjunction with the ASCE Convention, Denver, Colorado, May 1, 1985, Edited by R.D. Woods.

"Vibration Problems in Geotechnical Engineering", Proceedings of a Symposium sponsored by the Geotechnical Engineering Division, ASCE, in conjunction with the ASCE Convention in Detroit, Michigan, October 22, 1985, Edited by G. Gazetas and E.T. Selig.

"Richart Commemorative Lectures", Proceedings of a Session sponsored by the Geotechnical Engineering Division, ASCE, in conjunction with the ASCE Convention, Detroit, Michigan, October 23, 1985, Edited by R.D. Woods.

"Advances in the Art of Testing Soils Under Cyclic Conditions", Proceedings of a session sponsored by the Geotechnical Engineering Division, ASCE, in conjunction with the ASCE Convention, Detroit, Michigan, October 24, 1985, Edited by V. Khosla.

B) International Society for Soil Mechanics and Foundation Engineering (ISSMFE):

International Conferences On Soil Mechanics and Foundation Engineering,

11th, San Francisco, Aug. 1985.
12th, Rio de Janeiro, Aug. 1989.

C) International Association for Earthquake Engineering (IAEE):

World Conferences on Earthquake Engineering,

8th, San Francisco, June 1984.
9th, Tokyo, August 1988.

D) Soil Dynamics and Earthquake Engineering (Computational Mechanics Publications) (and Princeton, University):

International Conferences on Soil Dynamics and Earthquake Engineering,

1st, Southampton, U.K., Aug. 1983.
2nd, Aboard Queen Elizabeth 2, June 1985.
3rd, Princeton, N.J., June 1987.
4th, Mexico City, October 1989.

E) U.S. Air Force Engineering and Services Laboratory, Tyndall AFB, Florida, and U.S. Air Force Armament Laboratory, Eglin AFB, Florida, and U.S. Air Force Weapons Laboratory, Kirtland AFB, New Mexico.

International Symposia on Interaction of Non-Nuclear Munitions with Structures:

2nd, Panama City Beach, April 1985.
3rd, Panama City Beach, April 1987.
4th, Panama City Beach, April 1989.

Because of the large number of papers which the above list of proceedings represents and the additional large volume of papers in separate journals around the world, the papers actually cited herein are intended to be only representative. Each cited paper will open the door to several other sources which the reader may pursue if they are of interest.

PAPERS SUBMITTED TO THIS CONFERENCE (based on abstracts)

The papers submitted to this conference represent a broad range of testing techniques for both laboratory and field. While the statistics associated with this unscientific sampling may not be perfect, these statistics at least represent a broad cross section of research that has been performed recently and the interests of a significant number of attendees to this conference.

Table 1 presents a breakdown of the papers which were designated as part of THEME 1, Field and Laboratory Determination of Dynamic Soil Properties. In some cases papers are included in more than one category because they deal with more than one technique.

The testing methods discussed in this paper include all of those shown in Table 1 plus some methods not represented by papers to this conference.

FIELD TESTING METHODS

One of the important advances in field measurement of soil properties by wave propagation methods has been the improvement in "time of arrival" determination. Two basic methods are available, one is the direct time measurement and the other is the indirect method. Several instruments are available to accomplish timing measurements and these can be subdivided as follows:

Direct Time Resolution

- a) Dual channel oscilloscope with or without a storage feature,
- b) Digital Oscilloscope, two or more channels,
- c) Seismograph (signal enhancement feature),
- d) Wave Form Analyzer.
(last two above are also forms of digital oscilloscopes)

Indirect Time Resolution

- a) Cross correlation,
- b) Automated frequency domain techniques.

TABLE 1
SUMMARY OF PAPERS SUBMITTED

Description of Method	Number of Papers (*)
FIELD METHODS	
Seismic Refraction	1
Seismic Crosshole	2
Seismic Downhole	3
Seismic Cone	2
Spectral-Analysis-of-Surface Waves (SASW)	3
Falling Weight and others	1
Borehole Torsional Excitation	1
SPT, DMT, PMT Correlations/Go	2
LABORATORY METHODS	
Resonant Column	7
Cyclic Torsional Shear	3
Cyclic Simple Shear	3
Cyclic Triaxial	10
Ring Shear	1
Other (shaking box)	1

* All of the papers included in this table are presented in the reference list, but because this paper was written before the proceedings were published, it is not certain that they will all be included in the proceedings. Most of the papers included in this table will also be cited in the following text. In the reference list these papers will have the following citation: "2nd ICRAGEE&SD."

Much has already been written about direct time (or "By Eye") resolution of wave travel time including enhancement by reversed polarity of the source (Woods, 1978). However, indirect time resolution has not yet been widely used in geotechnical engineering applications requiring seismic wave timing. Woods and Stokoe (1985) and Woods (1986) describe the cross correlation and cross spectrum methods for determination of arrival time, and Mancuso et al (1989) describe similar work in Italy.

The indirect method of time resolution makes use of either dedicated Wave Form Analyzers or computer software to perform the required digital calculations. Both of these are readily available now.

With the development of these portable, multi-channel wave form analyzers, another major development in field measurement of ground characterization has become possible, namely, Spectral-Analysis-of-Surface-Waves (SASW) developed by Stokoe and his colleagues (Nazarian & Stokoe, 1984; Stokoe et al, 1989; and Nazarian 1991).

Many other uncertain aspects of shallow seismic testing have resolved over the last

decade. For example issues associated with frequency response of seismic energy receivers and generators have been studied, as described in Woods (1985) and Campanella and Stewart (1991), and found to not present significant problems with typically used equipment.

It is inevitable that electronics must be used in most techniques for measuring soil properties for dynamic applications. Hall (1985) described the limitations of instrumentation which must be recognized when attempting new or modified testing methods.

Other specific developments can be most easily described in association with each type of test listed in Table 1, and that will be done in the following.

-Seismic Refraction-

While seismic refraction was the topic of only one paper (Morris, 1991) to this conference, there is renewed interest in using this well known technique for more detailed ground characterization. Morris contribution may aid in applications of refraction to Geotomography Woods (1985) and Cumerlato et al in SAGEEP (1989). Denver and Steffensen (1989) coupled refraction and downhole in characterizing a broad area (several acres) for seismic analysis.

-Seismic Crosshole-

Although the representation of papers in this conference does not emphasize the seismic cross hole method, this technique is still probably the most widely used of all the shallow seismic methods, Fig. 1. Since 1981 several important papers concerned with crosshole have been published and some of those include:

- < Bodare and Massarch (1984) where several crosshole methods are compared and found to produce the same results,
- < Bouchovalas et al (1989) describe the use of crosshole in "very soft" clay,
- < Carabelli and Superbo (1983) and Crespellani et al (1989) describe uses of crosshole in Italy,
- < Mok et al (1986) describe the use of data from crosshole in determine soil damping,
- < Stokoe et al (1988) show how shear wave velocity from crosshole can be used to judge liquefaction potential (see Fig. 2),
- < Woods (1986) gives a description of several configurations for the crosshole test, and
- < SAGEEP (1989 & 1990) give examples of crosshole in geotomography. (see Fig. 3)

-Seismic Downhole-

Seismic downhole is now coupled closely with the seismic cone, but they will be treated separately here. Interpretation of downhole data has improved over the past decade first with exploratory work by Stokoe and his students as described in Woods (1986) and more recently in Mok, Stokoe and Wilson (1988) where the authors show how to use "inversion" theory to improve on downhole data interpretation (see Figs. 4 & 5).

Because this method requires only one borehole, there is much incentive to use it wherever possible, and by applying all of the

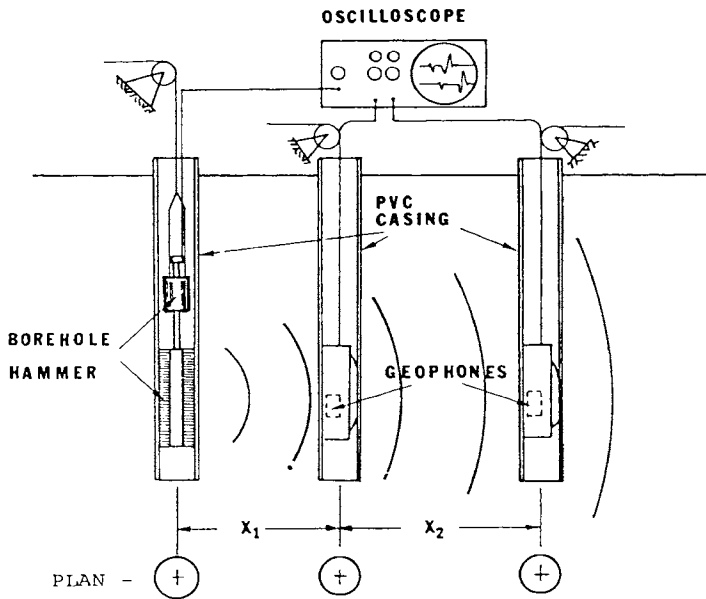

FIGURE 1 - Schematic of 3-hole crosshole array for interval velocity measurements. (from Woods & Stokoe, 1985)

recent analytical techniques, it is a valuable tool for shallow seismic exploration. This method too may be used by itself in a "pseudo geotomography" and in combination with other techniques in true geotomography. In the pseudo sense, several concentric rings of source locations around a borehole can provide for 3-D interpretation near the borehole.

In a related but theoretically different configuration, Uphole Seismic, success has not been achieved because the shear wave does not travel efficiently up the borehole wall. However, for the difficult deep sea environment, successful applications of the uphole approach have been described by Umehara et al (1984).

-Seismic Cone-

The seismic cone is treated separately because it has the fundamental difference that no independent borehole is required. All other aspects of the technique are the same. Robertson et al (1985) present one of the earliest descriptions of the seismic cone test.

The issues of interpretation described above in the papers on downhole can be directly applied, however, there are some issues associated with the complexity of the seismic cone apparatus that required additional investigation. Campanella and Stewart (1991) in a paper to this conference described tests with various sources and receivers in the seismic downhole configuration, and Campanella et al (1989) describe the use of digital filtering as an aid in data interpretation. Stewart and Campanella

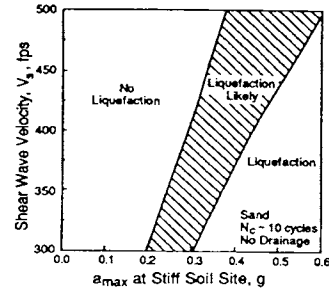

Liquefaction Potential Chart Based on V_s of Sand Layer and 10 Cycles of Strong Motion

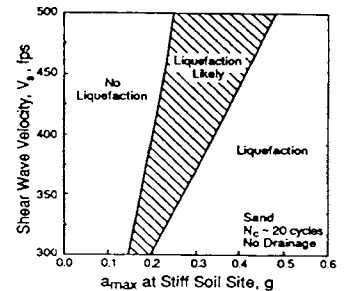

Liquefaction Potential Chart Based on V_s of Sand Layer and 20 Cycles of Strong Motion

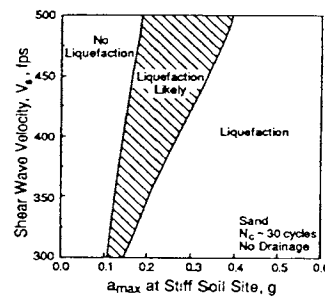

Liquefaction Potential Chart Based on V_s of Sand Layer and 30 Cycles of Strong Motion

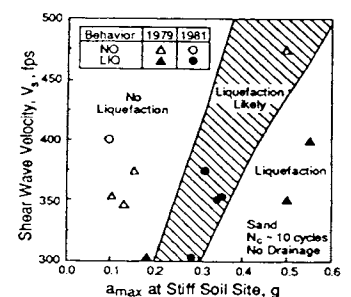

Comparison of Field Performance and Predicted Behavior in Imperial Valley, California

Figure 2 - Liquefaction Potential Linked to Shear Wave Velocity (from Stokoe et al, 1988b)

(1991) in another paper to this conference describe experiments to measure damping with the seismic cone.

Baldi et al (1988) show the use of two cone penetrometer rigs to perform seismic crosshole tests using two seismic cones, Fig. 6. The actual cones are not exactly the same as the one for the source is larger than the one for the receiver, Fig. 7.

Takimatsu (1988) described the use of a standard cone penetrometer for liquefaction analysis, and then described a "vibratory cone" for use in the same kind of study. The ratio of the static cone penetration to the cone penetration with vibration was used to distinguish liquefaction potential.

Considerable efforts are being expended in attempts to correlate seismic cone data (downhole seismic velocities and shear modulus) with CPT and DMT tests as in Thomann and Hryciw (1991) to this conference, Hryciw and Woods (1988) in a paper to ISOPT-1, and Baldi et al (1989).

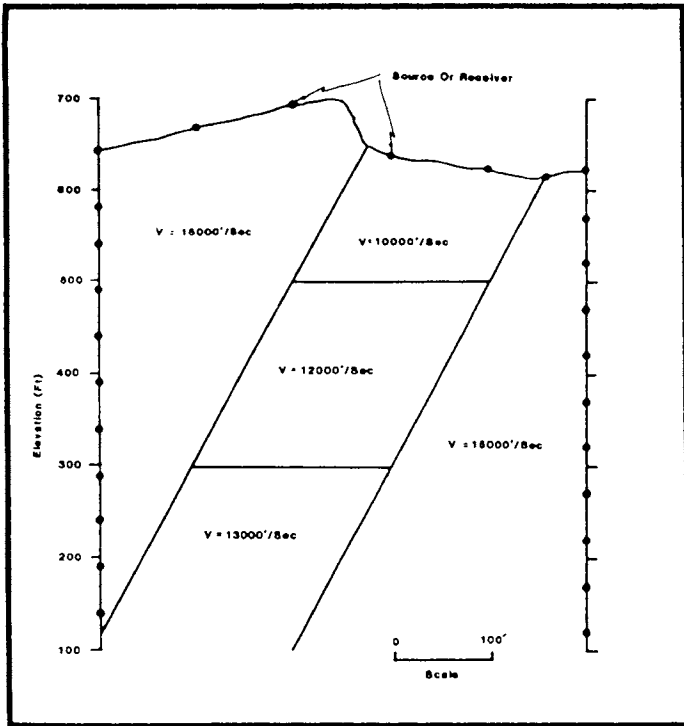

Figure 3a Hypothetical geologic cross section of an intrusive, dike-like feature showing assumed actual velocities. (from SAGEep 1989)

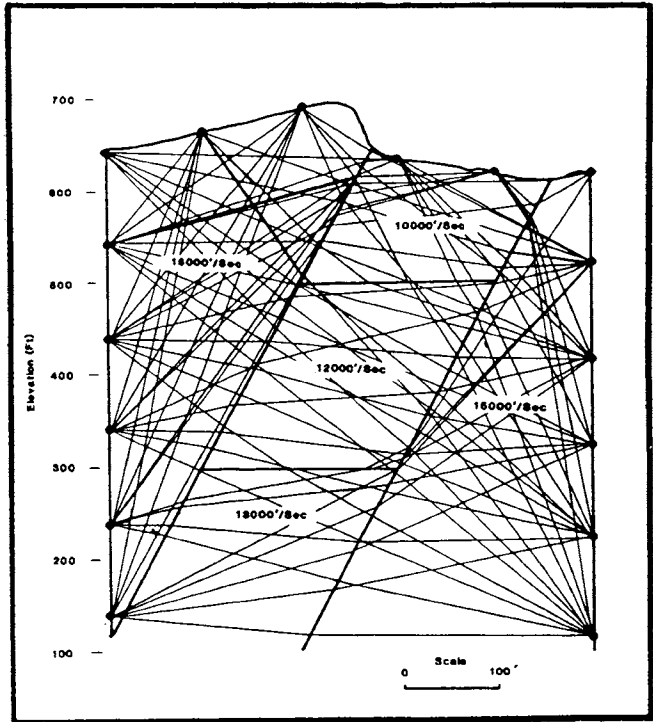

Figure 3b Curved ray path for Figure 3a Ray distortion is not significant where rays cross an interface at a nearly vertical angle of incidence.

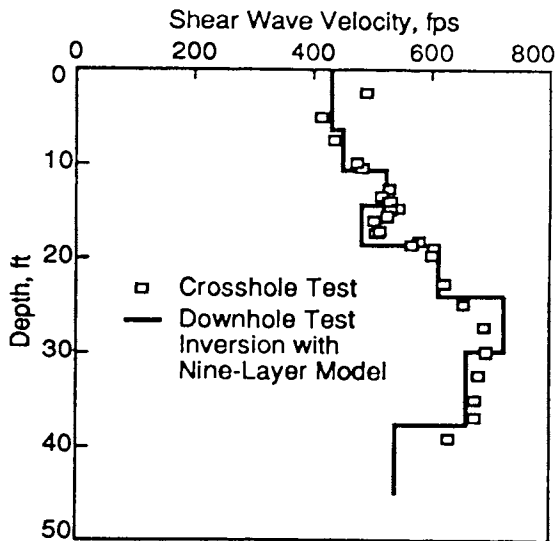

Fig. 4 - Comparison of Velocity Profiles from Crosshole Tests and from Inversion of Downhole Data (from Mok et al, 1988)

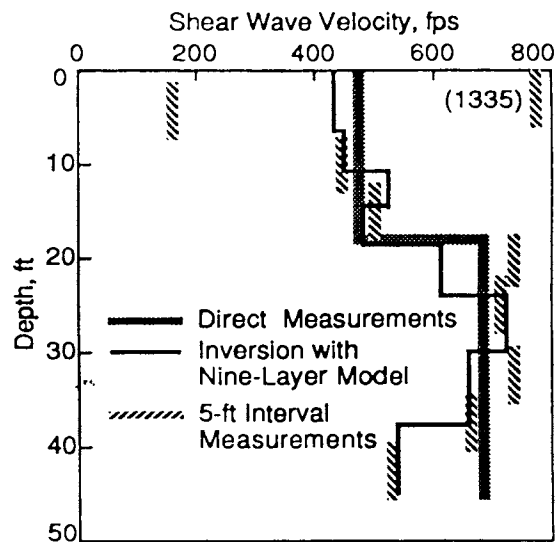

Fig. 5 - Comparison of Velocity Profiles from Downhole Tests Using Direct, and Interval Measurements and Inversion (from Mok et al, 1988)

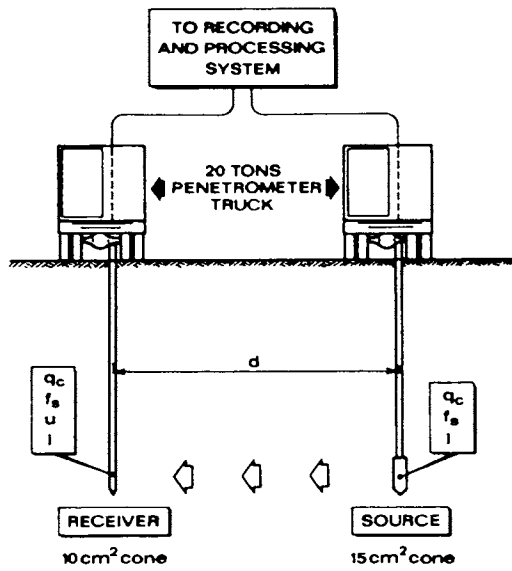

Fig. 6 Test with seismic cone (from Baldi et al, 1988)

The Spectral-Analysis-of-Surface-Waves method represents the most innovative approach to shallow seismic exploration in twenty years. This method, which requires no boreholes, can obtain data on soil layering including thickness of layers and shear modulus of layers, Fig. 8. The basics have been described by Nazarian and Stokoe (1984), Stokoe and Nazarian (1985) and Stokoe et al (1989). In other works, special features of SASW are described:

- < Stokoe et al (1988a) use of SASW in hard to sample soils, i.e. those with a variety of soil densities,
- < Stokoe et al (1988b) use of SASW in evaluation of liquefaction potential,
- < Nazarian (1991) to this conference, evaluates the detection of thin layers with SASW,
- < Hiltunen and Woods (1988) describe comparisons between crosshole and SASW shear wave velocity. (See Fig. 9)

-Falling Weight and Others-

Schneider and Studer (1991), in a paper to this conference, described the interpretation of the response of a falling weight on the trafficability of soils.

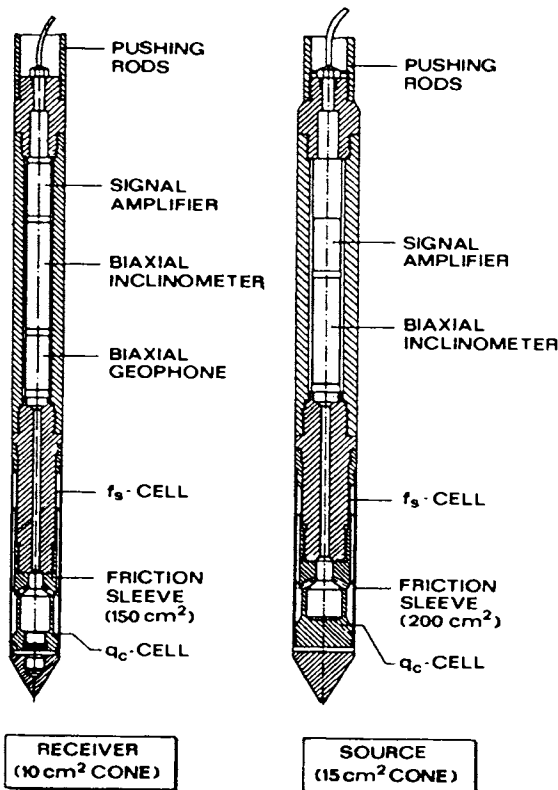
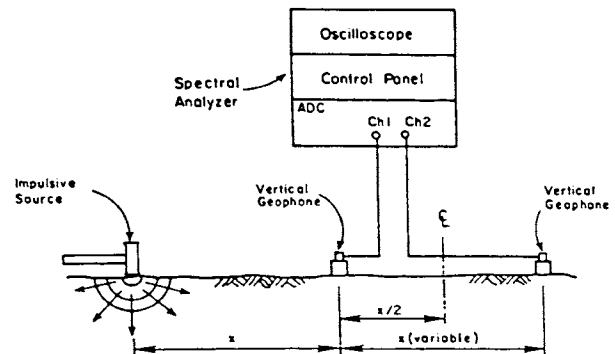

Fig. 7 Seismic cone. Source and receiver (from Baldi et al, 1988)



(a) General Configuration of SASW Tests

		0			Distance, Ft.	Geophone Spacing, Ft.
-24	-16	-8	8	16	24	
						1
						2
						4
						8
						16

(b) Common Receivers Midpoint Geometry

Fig. 8 - Schematic of Experimental Arrangement for SASW Tests. (from Stokoe & Nazarian, 1985)

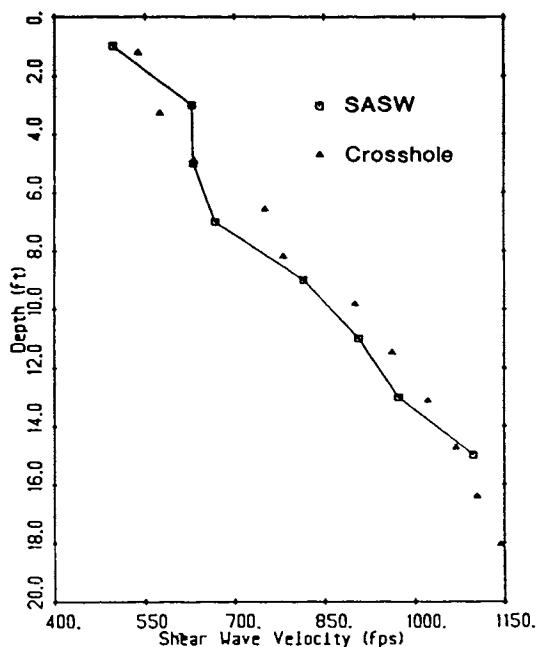

Figure 9 — Comparison of Shear Wave Velocity Profiles from SASW and Crosshole (Corrected) Tests (from Hiltunen & Woods, 1988)

Chang et al (1991) in a paper to this conference describe a method of backcalculation soil properties from microseismic data collected from the Lotung array in Taiwan. In a similar manner, Tokimatsu et al (1989) use strong motion records to determine soil properties by backcalculation. Furthermore, Yamamoto et al (1989) have described a means of determining the profile of the seabed using a gravity wave inversion procedure. These efforts may provide a fresh approach to determining soil properties by remote and non-direct means.

Henke and Henke (1991) describe in this conference a borehole torsional exciter which is intended to determine shear modulus in situ at the depth of the apparatus. This device has been tested in the laboratory and is ready for field trials.

-Correlations-

Many attempts have been made to correlate low amplitude shear modulus with other in situ testing techniques. Byrne (1991) in a paper to this conference described the correlation of G_0 to pressuremeter measurements. Others like Behpoor and Ghahramani (1989) have made recent attempts to correlate SPT with G_0 for clays. Sully and Campanella (1989) described correlations between DMT and G_0 .

-NonSeismic Geophysical-

There is much interest currently in the application of non-seismic geophysical methods in determination of properties for dynamic analysis. Ground penetrating radar (GPR) seems to

be on the threshold of becoming a valuable tool for ground characterization. The writer has had some rather disappointing experiences with the method, but new developments may change that view. Recently, two Proceedings have been published which present applications of Geophysical Methods to engineering and environmental problems, SAGDEEP (1989) and SAGDEEP (1990). The future should bring about a rapid evolution in applications of geophysical methods in geotechnical engineering.

LABORATORY TESTING METHODS

As indicated by Table 1, the most popular laboratory tests to determine soil properties for dynamic application are Resonant Column and Cyclic Triaxial. This does not necessarily mean that these are the best tests, but it does indicate something about the ease of operation and availability of equipment to perform the tests. Much has been written about the boundary conditions in various laboratory apparatus and about the uniformity of stresses within specimens in these apparatus, Woods 1978, Finn 1985 and Saada 1985, for example. The debate on these issues will continue in the literature as long as improvements; to equipment, in specimen preparation, and in data interpretation continue.

Once again representative papers describing various laboratory tests will be presented with full knowledge that equally as many papers have been omitted. There is no intent to show bias with regard to any particular test or configuration, however, tests which are represented by papers to this conference are given priority.

-Resonant Column-

Most resonant column tests are performed with steady state, harmonic excitation. That is not the only way to perform the test as demonstrated by Al-Sanad et al (1984) where they describe tests using random excitation as well as sinusoidal excitation. This group at Univ. of Maryland have been using the random excitation technique for many years. Stoll (1985) described computer aided interpretation technique for complex modulus from the resonant column test. Van Impe and Van Den Broeck (1989) used the free torsional pendulum interpretation of the response of a cylindrical soil specimen. Also, Tawfig et al (1988) modified a resonant column apparatus to apply an impulsive load and correlated results with conventional resonant column data.

Morris (1991) in a paper to this conference describes the determination of damping in the resonant column test using logarithmic increment rather than the more common logarithmic decrement.

Wu and Woods have used the random excitation technique for a large (20 in dia by 40 in high) resonant column apparatus for testing gravel, Fig. 10. Prange (1981b) used this technique for testing rock samples in a large (101mm by 200 to 400mm high) resonant column device in which the sample was supported on a large mass which was in turn supported on a single, central

ball bearing. Prange (1981a) also described a large (1m dia x 2m high) device for testing railroad ballast.

Resonant column apparatus have been used to evaluate the influence of soil reinforcement on shear modulus, Maher and Woods (1990) and Liu and Chang (1991). Bianchini (1985) described non-linear behavior of soils in the resonant column and Coop et al (1991) described comparison of resonant column tests with other laboratory testing methods.

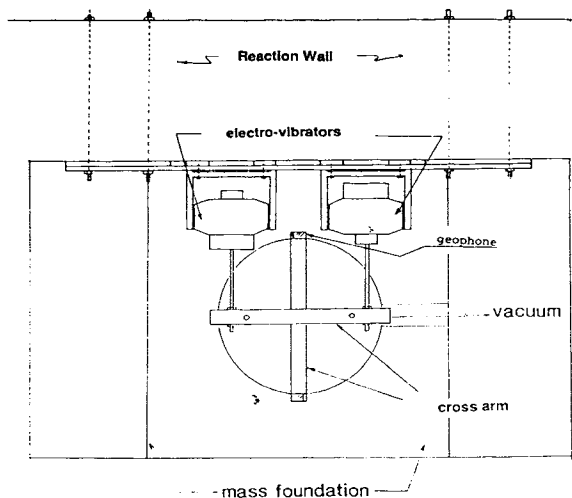

Top View of Apparatus

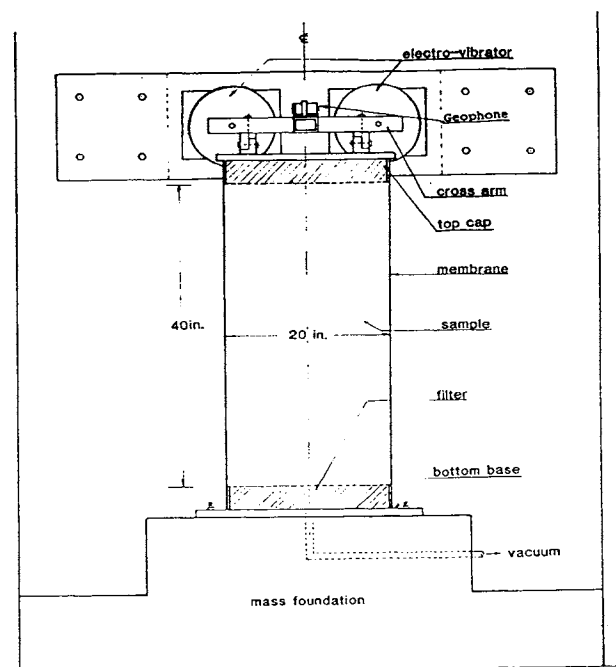

Fig. 10) Front View of Apparatus

Drnevich (1985) described recent developments in resonant column testing and interpretation. Drnevich was also instrumental in writing the ASTM Standard D 4515-87 on Resonant Column Testing of Soils.

Several authors described tests on specific soils using resonant column:

- < Yu and Qin (1991) tests on Fly Ash,
- < Cuellar and Navarro (1991) tests on very dense granular soils,
- < Du et al (1991) tests on Carbonate Sand,
- < Zen and Higuchi (1984) on cohesive soils.

-Cyclic Triaxial-

In 1981 at the First Conference of this series, El-Hosri et al (1981) described attempts to accurately measure low amplitude shearing strains in the cyclic triaxial test. The same research group reported on further advances and experimentation of that type in Hinchey et al (1987). Ladd and Dutko (1985) further confirmed that low shearing strains can be measured in the cyclic triaxial test if proper care and instrumentation is applied.

Bezuijen et al (1987) described cyclic triaxial tests at very low stress levels. These tests pose problems similar to the those requiring low strain levels.

Hugo et al (1987) coupled ultrasonic pulse testing with the cyclic triaxial test to compare modulus measurements by two methods in the same specimen.

Many other authors have reported on testing of specific soil types in cyclic triaxial apparatus:

- < Zen and Higuchi (1984) as reported earlier tested clay in Resonant Column and Cyclic Triaxial,
- < Guettler et al (1987) reported on cyclic hardening of sands,
- < Coop et al (1991) tests on clayey, sandy silt,
- < Chen (1991) tests on soft clay,
- < Lin and Chen (1991) also tests on clay,
- < Matsui et al (1991) also tests on clay,
- < Rahardjo et al (1991) tests on silty sands,
- < Tatsuoka et al (1991) tests on gravels,
- < Matsuzawa and Sugimora (1991) monotonic tests on sands,
- < Raybould and Brown (1991) report the development of new cyclic triaxial device.

-Cyclic Simple Shear-

Much has been written about the uniformity of stress in this test, but with the wire wound membranes, the test has maintained some popularity. Finn (1985) described the advantages of the constant volume cyclic simple shear test. Kovacs and Leo (1981) reported on the influence of diameter to height ratio in this test up to that date.

Ishihara and Nagase (1985) reported on multi-directional shear in a cyclic simple shear apparatus, Fig. 11.

In papers submitted to this conference, some specific soil tests were reported:

- < Lee (1991) reported on deformation of sand under cyclic simple shear,
- < Tatsuoka et al (1991) also reported on settlement of sand in this test,
- < Teachavorasinskun et al (1991) reported on cyclic vs monotonic tests on sand,
- < Zimmie and Normandeau (1991) described tests on sandy silt in cyclic simple shear.

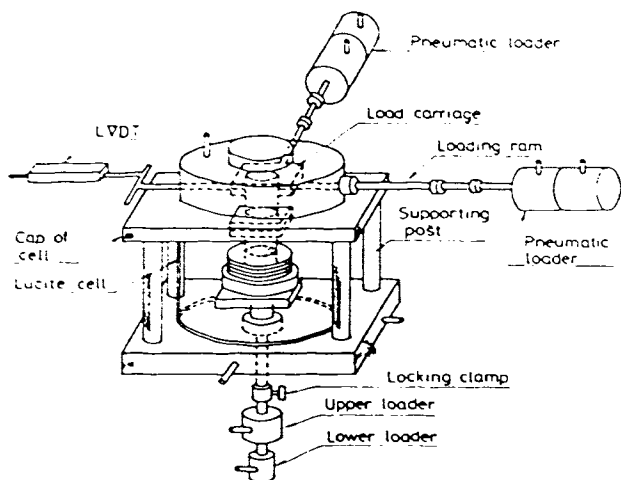

Fig. 11 Simple shear test device
(from Ishihara & Nagase, 1985)

-Cyclic Torsional Shear-

Both solid and hollow specimens can be tested in cyclic torsional shear. The stress and strain distribution in such specimens is more uniform than in most other common testing arrangements. Saada (1985) has presented the arguments for the advantages of this specimen configuration. Woods (1978) described the similarity of the stresses on an element of a hollow cylindrical specimen to the stresses in the ground under earthquake excitation as reported by Hardin and Drnevich in earlier publication.

This configuration of specimen has been adapted to resonant column and cyclic simple shear. Woods (1978) described work by Drnevich

in performing high amplitude resonant column devices with hollow cylinders and work continued on developing combined resonant column/cyclic torsional shear, Ray and Woods (1988). Alarcon-Guzman (1986) further described a new apparatus designed, built, and described by Drnevich (1985), Fig. 12. Maher and Woods (1990) describe tests on reinforced sand with another version of the Drnevich combined resonant column and torsional shear apparatus.

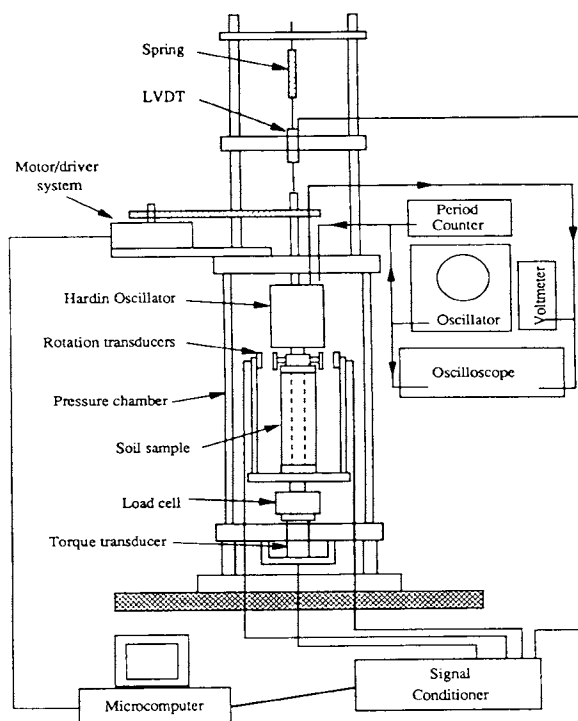

Figure 12 Quasi Static Torsional Shear - Resonant Column (QSTS-RC) Device
(Built by Soil Dynamics Instruments)

Dobry et al (1985) described evaluation of liquefaction behavior of silty sands using the cyclic torsional apparatus. Ishibashi et al (1985) described more than a decade of testing with cyclic torsional shear devices of various configurations. Bhatia et al (1985) describe comparative studies using three cyclic type tests: cyclic simple shear, cyclic torsional shear and cyclic triaxial tests.

Papers submitted to this conference describe work with this type of device:

- < Stephenson et al (1991) describe results of large prestraining on Ottawa Sand,
- < You and Chang (1991) describe tests on sand with a large diameter (10" O.D. by 8" I.D.) hollow cylinder apparatus.

-High Pressure Tests-

Shock loadings on soils produce response which is controlled by properties which are somewhat different that those used in conven-

tional analyses. These have been measured in various ways mainly by the military labs. The results of some of these tests using shock tubes to load soils are reported by Vander Kogel et al (1981). Charlie et al (1985), Veyera and Charlie (1987), and Felice et al (1985) reported on the use of the split Hopkinson bar to shock load a soil, and Farr and Woods (1988) describe the use of a blasting cap loading test to determine the compression characteristics of soils under very rapid and very high pressure loading.

-Bender Elements_

While not a testing device itself, the piezo-electric bender element is becoming a valuable tool in evaluating low strain properties of soils in a wide variety of configurations. Dyvik and Madshus (1985) described the use of bender elements in triaxial, direct simple shear and oedometer devices, Fig. 13. Dyvik and Olsen (1989) described measurement of G_0 in the oedometer device in clay and Thomann and Hryciw (1990) describe a similar application in an oedometer for sands, Fig. 14.

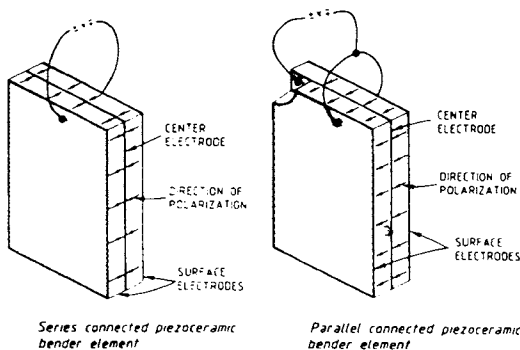

Figure 13 Parallel and series connected piezoceramic bender elements (Dyvik and Madshus, 1985).

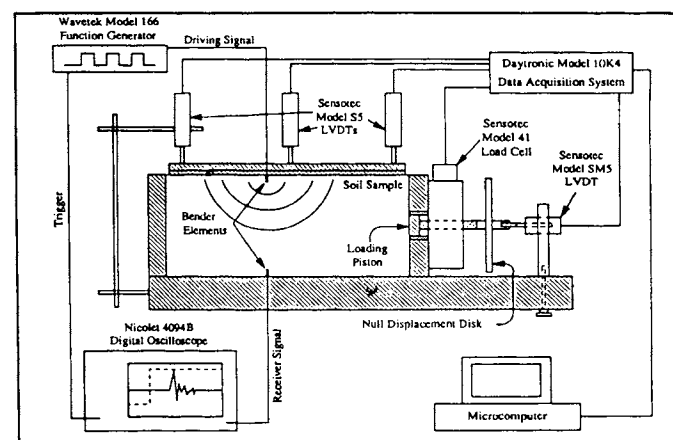

Figure 14 Bender Element - Oedometer (BEO) (Thomann & Hryciw, 1990)

-Miscellaneous Tests-

Bencat (1991) describes a comparison between static and dynamic soil parameters using a "Box Test." Kousho (1984) described liquefaction analysis compared with shake table tests. Lemos and Vaughan (1991) report on results of tests using a ring shear apparatus determining shear under rapid loading. Pamukcu and Suhayda (1987) described tests on clay using a triaxial vane device.

ACKNOWLEDGEMENTS

The writer wants to acknowledge the continuing inspiration and encouragement of his colleagues, Prof. D.H. Gray and Prof. Roman Hryciw. He further recognizes the importance to the contributions of two generations of doctoral students, and specially the current candidates, N. Gucunski, X. Qian, L. Ali and N. Al Shayea. Finally, no work on properties for dynamic analysis would have come about without the early inspiration and direction of Prof. Emeritus F.E. (Bill) Richart, Jr.

REFERENCES

- Alarcon-Guzman, A. (1986), "Cyclic Stress-Strain and Liquefaction Characteristics of Sands," Ph.D. Thesis, Purdue University.
- Al-Sanad, H. and Aggour, M.S. (1984), "Dynamic Soil Properties From Sinusoidal and Random Vibrations," Proceedings of the 8th World Conference on Earthquake Engineering, San Francisco, July 21-28, Vol III, pp. 15-22.
- Baldi, G.; Bruzzi, D.; Superbo, S.; Battaglio, M. and Jamiolkowski, M. (1988), "Seismic Cone in Po River Sand," Penetration Testing 1988, Proceedings of the First International Symposium on Penetration Testing/ISOPT-1, Orlando 20-24 March, Vol. 2, pp. 643-650.
- Baldi, G.; Bellotti, R.; Ghionna, V.N.; Jamiolkowski, M. and Lopresti, D.C.F. (1989), "Modulus of Sands from CPT's and DMT's," Proceedings of the Twelfth International Conference on Soil Mechanics and Foundation Engineering, Rio de Janeiro, Aug. 13-18, Vol 1, pp 165-170.
- Behpoor, L. and Ghahramani, A. (1989), "Correlation of SPT to Strength and Modulus of Elasticity of Cohesive Soils," Proceedings of the Twelfth International Conference on Soil Mechanics and Foundation Engineering, Rio de Janeiro, Aug. 13-18, Vol 1, pp 175-178.
- Bencat, J. (1991), "Verification by Comparison Between Static and Dynamic Engineering Soil Parameters Evaluated by Means of Box Tests," 2nd ICRAEE&SD.
- Bezuijen, A.; Hjortnaes-Pedersen, A.G.I.; and Molenkamp, P. (1987), "Cyclic Triaxial Tests At Low Stresses For Parameter Determination," Soil Dynamics and Liquefaction. Developments in Geotechnical Engineering 42, Elsevier, from 3rd International Conference on Soil Dynamics and Earthquake Engineering, Princeton, N.J., June 22-24, pp. 283-297.

- Bhatia, S.; Schwab, J. and Ishibashi, I. (1985), "Cyclic Simple Shear, Torsional Shear, and Triaxial-A Comparative Study," ADVANCES IN THE ART OF TESTING SOILS UNDER CYCLIC CONDITIONS, Proceedings of a session sponsored by the Geotechnical Engineering Division in conjunction with the ASCE Convention in Detroit, Mi, Oct. 24, pp. 232-286.
- Bianchini, G. (1985), "Evaluating Nonlinear Soil Behavior Using the Resonant Column," ADVANCES IN THE ART OF TESTING SOILS UNDER CYCLIC CONDITIONS, Proceedings of a session sponsored by the Geotechnical Engineering Division in conjunction with the ASCE Convention in Detroit, Mi, Oct. 24, pp. 197-231.
- Bodare, A. and Massarch, K.R. (1984), "Determination of Shear Wave Velocity by Different Cross-Hole Methods," Proceedings of the 8th World Conference on Earthquake Engineering, San Francisco, Vol. III, pp. 39-45.
- Bouchovalas, G.; Kalteziotis, N.; Sabatakakis, N. and Zervogiannis, C. (1989), "Shear Wave Velocity in a Very Soft Clay-Measurement and Correlations," Proceedings of the Twelfth International Conference on Soil Mechanics and Foundation Engineering, Rio de Janeiro, Aug. 13-18, Vol 1, pp 191-194.
- Byrne, P.M. and Salgado, F. (1991), "Maximum Shear Modulus Values for Sand From Pressuremeter Tests," 2nd ICORAGE&SD.
- Campanella, R.G.; Baziw, E.J. and Sully, J.P. (1989), "Interpretation of Seismic Cone Data Using Digital Filtering Techniques," Proceedings of the Twelfth International Conference on Soil Mechanics and Foundation Engineering, Rio de Janeiro, Aug. 13-18, Vol 1, pp 195-198.
- Campanella, R.G. and Stewart, W.P. (1991), "Determination of Shear Wave Velocity Using a Variety of Sources, Receivers, and Calculation Methods," 2nd ICORAGE&SD.
- Carabelli, E. and Superbo, S. (1983), "Caratterizzazione dinamica dei terreni di fondazione mediante misure in sito della velocita di propagazione di onde di volume, A.G.I. XV, Conf. Naz. Geot., Spoleto, Vol. I, pp. 77-83.
- Chang, C-Y., Mok, C.M., Power, M.S., Tang, Y.K. and Tang, H.T. (1991), "Development of Shear Modulus Reduction Curves Based on Lotung Down-hole Ground Motion Data," 2nd ICORAGE&SD.
- Charlie, W.A.; Abt, S.R. and Veyera, G.E. (1985) "Dynamic Pore Pressure Response of Saturated Soil Under Shock Loading," Proceedings of the Second Symposium on The Interaction of Non-Nuclear Munitions With Structures, April 15-18, Panama City Beach, Florida.
- Chen, Z. (1991), "The Dynamic Properties of Soft Clay," 2nd ICORAGE&SD.
- Coop, M.R., Silvestri, F., Viggiani, F. and Vinale, F. (1991), "Mechanical Behavior of a Clayey Sandy Silt Using Different Static, Cyclic and Dynamic Testing Procedures," 2nd ICORAGE&SD.
- Crespellani, T.; Ghinelli, A. and Vannucchi, G. (1989), "An Evaluation of the Dynamic Shear Modulus of a Cohesive Deposit Near Florence, Italy," Proceedings of the Twelfth International Conference on Soil Mechanics and Foundation Engineering, Rio de Janeiro, Aug. 13-18, Vol 3, pp 1935-1940.
- Cuellar, V. and Navarro, F. (1991), "Elasto-Plastic Behavior of a Very Dense Granular Material Under Earthquake Type of Loading," 2nd ICORAGE&SD.
- Denver, H. and Steffensen, H. (1989), "Ground Moduli Determined by Seismic Methods," Proceedings of the Twelfth International Conference on Soil Mechanics and Foundation Engineering, Rio de Janeiro, Aug. 13-18, Vol. 1, pp 215-222.
- Doanh, T. (1991), "Undrained Cyclic Tests on Hollow Cylinder," 2nd ICORAGE&SD.
- Dobry, R., Vasquez-Herrera, A., Mohamad, R. and Vucetic, M. (1985), "Liquefaction Flow Failure of Silty Sand by Torsional Cyclic Tests," ADVANCES IN THE ART OF TESTING SOILS UNDER CYCLIC CONDITIONS, Proceedings of a session sponsored by the Geotechnical Engineering Division in conjunction with the ASCE Convention in Detroit, Mi, Oct. 24, pp. 29-50.
- Drnevich, V.P. (1985), "Recent Developments in Resonant Column Testing," RICHART COMMEMORATIVE LECTURES, Proceedings of a session sponsored by the Geotechnical Engineering Division, in conjunction with the ASCE Convention Detroit, MI, Oct. 23, pp. 79-107.
- Du, J., Zhu, L-G. and Wu, X-F. (1991), "The Dynamic Properties of Carbonate Sand," 2nd ICORAGE&SD.
- Dyvik, R. and Olsen, T.S. (1989), "Gmax Measured in Oedometer and DSS Tests Using Bender Elements," Proceedings of the Twelfth International Conference on Soil Mechanics and Foundation Engineering, Rio de Janeiro, Aug. 13-18, Vol 1, pp 39-42.
- El-Hosri, M.S.; Biarez, J. and Hicher, P.Y. (1981), "Dynamic Triaxial and Vibratory In-Situ Behavior of Cohesive Soil," Proceedings of the International Conference on Recent Advances in Geotechnical Earthquake Engineering and Soil Dynamics, St. Louis, April 26-May 3, 1981, Vol. III, pp. 897-907.
- Farr, J.V. and Woods, R.D. (1988), "A Device For Evaluating One-Dimensional Compressive Loading Rate Effects," Geotechnical Testing Journal, GTHODJ, ASTM, Vol. 11, No. 4, June, pp. 269-275.
- Felice, C.W.; Brown, J.A.; Gaffney, E.S. and Olsen, J.M. (1985). "An Investigation Into The High Strain-Rate Behavior of Compacted Sand Using the Split-Hopkinson Pressure Bar Technique," Proceedings of The Second Symposium on The Interaction of Non-Nuclear Munitions with Structures, April 15-18, Panama City Beach, Florida.

- Finn, W.D.L. (1985), "Aspects of Constant Volume Cyclic Simple Shear," ADVANCES IN THE ART OF TESTING SOILS UNDER CYCLIC CONDITIONS, Proceedings of a session sponsored by the Geotechnical Engineering Division in conjunction with the ASCE Convention in Detroit, Mi, Oct. 24, pp. 74-98.
- Guettler, U.; Thiel, G. and Jessberger, H.L. (1987), "Cyclic Hardening of Sand During Earthquake Events," Soil Dynamics and Liquefaction, Developments in Geotechnical Engineering 42, Elsevier, from 3rd International Conference on Soil Dynamics and Earthquake Engineering, Princeton, N.J., June 22-24, pp. 107-122.
- Hall, J.R. (1985), "Limits on Dynamic Measurements and Instrumentation," RICHART COMMEMORATIVE LECTURES, Proceedings of a session sponsored by the Geotechnical Engineering Division, in conjunction with the ASCE Convention Detroit, MI, Oct. 23, pp. 108-119.
- Henke, W. and Henke, R. (1991), "Cyclic Tests Conducted Using Laboratory Prototype of In situ Geotechnical Testing System," 2nd ICRAGEE&SD.
- Hicher, P.Y.; El Hosri, M.S. and Homsy, M. (1987), "Cyclic Properties of Soils Within A Large Range of Strain Amplitude," Soil Dynamics and Liquefaction, Developments in Geotechnical Engineering 42, Elsevier, from 3rd International Conference on Soil Dynamics and Earthquake Engineering, Princeton, N.J., June 22-24, pp. 365-378.
- Hiltunen, D.R. and Woods, R.D. (1988), "SASW and Crosshole Test Results Compared," EARTHQUAKE ENGINEERING AND SOIL DYNAMICS II - RECENT ADVANCES IN GROUND-MOTION EVALUATION, Geotechnical Special Publication No. 20, ASCE, Specialty Conference, June 27-30, Park City, Utah, pp. 264-278.
- Hryciw, R.D. and Woods, R.D. (1988), "DMT-Cross Hole Shear Correlations," Penetration Testing 1988, Proceedings of the First International Symposium on Penetration Testing/ISOPT-1, Orlando 20-24 March, Vol. 1, pp. 117-136.
- Hugo, F.; Engelbrecht, J.C. and DuToit, J. (1989), "Correlation of Elastic Engineering Parameters Obtained from Dynamic Triaxial Tests With Ultrasonic Tests," Proceedings of the Twelfth International Conference on Soil Mechanics and Foundation Engineering, Rio de Janeiro, Aug. 13-18, Vol 1, pp 233-238.
- Ishibashi, I., Kawamura, M. and Bhatia, S. (1985), "Torsional Simple Shear Apparatus for Drained and Undrained Cyclic Testing," ADVANCES IN THE ART OF TESTING SOILS UNDER CYCLIC CONDITIONS, Proceedings of a session sponsored by the Geotechnical Engineering Division in conjunction with the ASCE Convention in Detroit, Mi, Oct. 24, pp. 51-73.
- Ishihara, K. and Nagase, H. (1985), "Multi-Directional Irregular Loading Tests on Sand," ADVANCES IN THE ART OF TESTING SOILS UNDER CYCLIC CONDITIONS, Proceedings of a session sponsored by the Geotechnical Engineering Division in conjunction with the ASCE Convention in Detroit, Mi, Oct. 24, pp. 99-119.
- Kousho, T. (1984), "Liquefaction Analysis Compared With Shake Table Test," Proceedings of the 8th World Conference on Earthquake Engineering, San Francisco, July 21-28, Vol III, pp. 135-142.
- Kovacs, W.D. and Leo, E. (1981), "Cyclic Simple Shear of Large Scale Sand Samples: Effects of Diameter to Height Ratio," Proceedings of the International Conference on Recent Advances in Geotechnical Earthquake Engineering and Soil Dynamics, St. Louis, April 26-May 3, 1981, Vol. III, pp. 897-907.
- Ladd, R.S. and Dutko, P. (1985), "Small Strain Measurements Using Triaxial Apparatus," ADVANCES IN THE ART OF TESTING SOILS UNDER CYCLIC CONDITIONS, Proceedings of a session sponsored by the Geotechnical Engineering Division in conjunction with the ASCE Convention in Detroit, Mi, Oct. 24, pp. 148-165.
- Lee, C-J. (1991), "The Deformation of Sand Under Cyclic Simple Shear Loading," 2nd ICRAGEE&SD.
- Lemos, L.J.L. and Vaughan, P.R. (1991), "Shear Strength of Shear Surfaces Under Rapid Loading," 2nd ICRAGEE&SD.
- Lin, M-L. and Chen, J-Y. (1991), "Degradation Behavior of Normally Consolidated Clay Under Cyclic Loading Condition," 2nd ICRAGEE&SD.
- Liu, H.C. and Chang, N.Y. (1991), "Static and Dynamic Properties of a Geotextile Reinforced Sand," 2nd ICRAGEE&SD.
- Lord, A.E., Jr. and Koerner, R.M. (1982), "Electromagnetic Methods in Subsurface Investigations," Updating Subsurface Samplings of Soils and Rocks and Their In-Situ Testing, Engineering Foundation, New York, Proceedings of Conference, Santa Barbara, CA, Jan. 3-8, pp. 113-134.
- Maher, M.H. and Woods, R.D. (1990), "Dynamic Response of Sand Reinforced With Randomly Distributed Fibers," Journal of Geotechnical Engineering, ASCE, Vol. 116, No. 7, July, pp. 1116-1131.
- Mancuso, C.; Simonelli, A.L. and Vinale, F. (1989), "Numerical Analysis of In Situ S-Wave Measurements," Proceedings of the Twelfth International Conference on Soil Mechanics and Foundation Engineering, Rio de Janeiro, Aug. 13-18, Vol 1, pp 277-280.
- Matsui, T., Abe, N., and Bahr, M.A. (1991), "Degradation of Saturatged Clays After Cyclic Loading," 2nd ICRAGEE&SD.

- Matsuzawa, H. and Sugimura, M. (1991), "Cyclic Undrained Behavior of Saturated Sand Under Monotonic Loading," 2nd ICARGE&SD.
- Mok, Y.J.; Sanchez-Salinero, I.; Stokoe, K.H. II and Roesset, J. (1986), "In Situ Damping Measurements by Crosshole Seismic Method," Use of In Situ Tests in Geotechnical Engineering, Geotechnical Special Publication No. 6, Proceedings of an ASCE Specialty Conference, Virginia Tech, Blacksburg, VA, June 23-25, pp. 336-375.
- Mok, Y.J.; Stokoe, K.H. II and Wilson, C.R. (1988), "Analysis of Downhole Seismic Data Using Inverse Theory," Proceedings of the 9th World Conference on Earthquake Engineering, Aug. 2-9, Vol. III, pp. 65-70.
- Morris, D. (1991), "A Simple Algorithm for Obtaining Dynamic Soil Properties with Depth from Surface Refraction Data," 2nd ICARGE&SD.
- Morris, D. and Bakas, G.J. (1991), "Soil Damping by the Logarithmic Increment Method," 2nd ICARGE&SD.
- Nazarian, S. and Stokoe, K.H. II (1984), "In Situ Shear Wave Velocities From Spectral Analysis of Surface Waves," Proceedings of the 8th World Conference on Earthquake Engineering, San Francisco, July 21-28, Vol III, pp. 31-38.
- Nazarian, S. (1991), "Resolution of Surface Wave Method in Determining Stiffness of Thin Layers," 2nd ICARGE&SD.
- Pamukcu, S. and Suhayda, J.N. (1987), "High Resolution Measurement of Shear Modulus of Clay Using Triaxial Vane Device," Soil Dynamics and Liquefaction, Developments in Geotechnical Engineering 42, Elsevier, from 3rd International Conference on Soil Dynamics and Earthquake Engineering, Princeton, N.J., June 22-24, pp. 307-321.
- Prange, B. (1981a), "Resonant Column Testing of Railroad Ballast," Proceedings of the Xth International Conference on Soil Mechanics and Foundation Engineering, Stockholm, June 15-19, Vol. 3, pp. 273-278.
- Prange, B. (1981b), "Stochastic Excitation of Rock Masses," Oral Discussion, Proceedings of the Xth International Conference on Soil Mechanics and Foundation Engineering, Stockholm, June 15-19, Vol. 4, pp. 879-880.
- Rahardjo, P.P., Brandon, T.L., and Clough, G.W. (1991), "Laboratory Study of the Undrained Behavior of Silty Sands," 2nd ICARGE&SD.
- Ray, R.P. and Woods, R.D. (1988), "Modulus and Damping Due to Uniform and Variable Cyclic Loading," Journal of the Geotechnical Engineering, Vol. 114, No. 8, Aug., pp. 861-875.
- Raybould, M.J. and Brown, S.F. (1991), "Development of a Triaxial Testing Facility to Determine the Dynamic Properties," 2nd ICARGE&SD.
- Robertson, P.K.; Campanella, R.G.; Gillispie, D. and Rice, A. (1985), "Seismic CPT to Measure In-Situ Shear Wave Velocity," MEASUREMENT AND USE OF SHEAR WAVE VELOCITY FOR EVALUATING DYNAMIC SOIL PROPERTIES, Proceedings of a session sponsored by the Geotechnical Engineering Division in conjunction with the ASCE Convention in Denver, CO, May 1, pp. 18-34.
- Saada, A.S. (1985), "On Cyclic Testing With Thin Long Hollow Cylinders," ADVANCES IN THE ART OF TESTING SOILS UNDER CYCLIC CONDITIONS, Proceedings of a session sponsored by the Geotechnical Engineering Division in conjunction with the ASCE Convention in Detroit, Mi, Oct. 24, pp. 1-28.
- SAGEEP (1989), Proceedings of the Symposium on the Application of Geophysics to Engineering and Environmental Problems, Colorado School of Mines, Golden, CO., March 13-16, 489 p.
- SAGEEP (1990), Proceedings of the Symposium on the Application of Geophysics to Engineering and Environmental Problems, Colorado School of Mines, Golden, CO., March 12-15, 367 p.
- Schneider, H.R. and Studer, J.A. (1991), "Impact Apparatus for the Characterization of Soil Properties to Predict Offroad Trafficability," 2nd ICARGE&SD.
- Silver, M.L. (1981), "Load, Deformation, and Strength Behavior of Soils under Dynamic Load," Proceedings of the International Conference on Recent Advances in Geotechnical Earthquake Engineering and Soil Dynamics, St. Louis, April 26-May 3, 1981, Vol. III, pp. 873-895.
- Stephenson, R.W., Stringer, S.K., and Sutterer, K. (1991), "The Influence of Large Prestrains on Dynamic Properties of Sand," 2nd ICARGE&SD.
- Stewart, W.P. and Campanella, R.G. (1991), "In-Situ Measurement of Damping in Sands and Silts," 2nd ICARGE&SD.
- Stokoe, K.H. II; Lee, S.H.H. and Knox, D.P. (1985), "Shear Moduli Measurements Under True Triaxial Stresses," ADVANCES IN THE ART OF TESTING SOILS UNDER CYCLIC CONDITIONS, Proceedings of a session sponsored by the Geotechnical Engineering Division in conjunction with the ASCE Convention in Detroit, Mi, Oct. 24, pp. 166-185.
- Stokoe, K.H. II and Nazarian, S. (1985), "Use of Rayleigh Waves in Liquefaction Studies," MEASUREMENT AND USE OF SHEAR WAVE VELOCITY FOR EVALUATING DYNAMIC SOIL PROPERTIES, Proceedings of a session sponsored by the Geotechnical Engineering Division in conjunction with the ASCE Convention in Denver, CO, May 1, pp. 1-17.
- Stokoe, K.H. II; Nazarian, S.; Rix, G.; Sanchez-Salinero, I.; Sheu, J-C. and Mok, Y-J. (1988a), "In Situ Seismic Testing of Hard-To-Sample Soils by Surface Wave Method," EARTHQUAKE ENGINEERING AND SOIL DYNAMICS II - RECENT ADVANCES IN GROUND-MOTION EVALUATION, Geotechnical Special Publication No. 20, ASCE, Specialty Conference, June 27-30, Park City, Utah, pp. 264-278.

- Stokoe, K.H. II; Roesset, J.M.; Bierschwale, J.G. and Aouad, M. (1988b), "Liquefaction Potential of Sands From Shear Wave Velocity," Proceedings of the 9th World Conference on Earthquake Engineering, Aug. 2-9, Vol. III, pp. 213-218.
- Stokoe, K.H. II; Rix, G.J. and Nazarian, S. (1989), "In Situ Seismic Testing With Surface Waves," Proceedings of the Twelfth International Conference on Soil Mechanics and Foundation Engineering, Rio de Janeiro, Aug. 13-18, Vol. 1, pp 331-334.
- Stoll, R.D. (1985), "Computer-Aided Studies of Complex Soil Modulus," MEASUREMENT AND USE OF SHEAR WAVE VELOCITY FOR EVALUATING DYNAMIC SOIL PROPERTIES, Proceedings of a session sponsored by the Geotechnical Engineering Division in conjunction with the ASCE Convention in Denver, CO, May 1, pp. 18-34.
- Sully, J.P. and Campanella, R.G. (1989), "Correlation of Maximum Shear Modulus With DMT Test Results in Sand," Proceedings of the Twelfth International Conference on Soil Mechanics and Foundation Engineering, Rio de Janeiro, Aug. 13-18, Vol. 1, pp 339-343.
- Tatsuoka, F.; Sasaki, T. and Yamada, S. (1984), "Settlement in Saturated Sands Induced by Cyclic Undrained Simple Shear," Proceedings of the 8th World Conference on Earthquake Engineering, San Francisco, July 21-28, Vol III, pp. 95-102.
- Tatsuoka, F., Yasuda, M., Yamada, K., Yamada, S., and Manabe, S. (1991), "Cyclic Undrained Behavior of an Undisturbed Gravel for Aseismic Design of a Bridge Foundation," 2nd ICRAGEE&SD.
- Tawfiq, K.S.; Aggour, M.S. and Al-Sanad, H.A. (1988), "Dynamic Properties of Cohesive Soils From Impulse Testing," Proceedings of the 9th World Conference on Earthquake Engineering, Aug. 2-9, Vol. III, pp. 11-16.
- Teachavorasinskun, S., Shibuya, S., Tatsuoka, F. and Horii, N. (1991), "Stiffness of Sand in Simple Shear: Cyclic Versus Monotonic Loadings," 2nd ICRAGEE&SD.
- Thomann, T.G. and Hryciw, R.D. (1990), "Laboratory Measurement of Small Strain Modulus Under Ko Conditions," Geotechnical Testing Journal, GTJODJ, ASTM, Vol. 13, No.2, June, pp. 79-105.
- Thomann, T.G. and Hryciw, R.D. (1991), "Seismic Downhole, CPT and DMT Correlations in Sand," 2nd ICRAGEE&SD.
- Tokimatsu, K. (1988), "Penetration Tests for Dynamic Problems," Penetration Testing 1988, Proceedings of the First International Symposium on Penetration Testing/ISOPT-1, Orlando 20-24 March, Vol. 1, pp. 117-136.
- Tokimatsu, K.; Midorikawa, S. and Yoshimi, Y. (1989), "Dynamic Soil Properties Obtained From Strong Motion Records," Proceedings of the Twelfth International Conference on Soil Mechanics and Foundation Engineering, Rio de Janeiro, Aug. 13-18, Vol 3, pp 2015-2018.
- Umehara, Y.; Ohneda, H. and Matsumoto, K. (1984), "In-Situ Soil Investigation and Evaluation of Dynamic Properties of Sandy Soils in Very Deep Sea," Proceedings of the 8th World Conference on Earthquake Engineering, San Francisco, July 21-28, Vol III, pp. 71-78.
- Van Impe, W.F. and Van Den Broeck, M. (1989), "Developments and Modeling of the Free Torsion Pendulum Test," Proceedings of the Twelfth International Conference on Soil Mechanics and Foundation Engineering, Rio de Janeiro, Aug. 13-18, Vol 1, pp 131-137.
- Vander Kogel, H.; Van Loon-Engels, C.H. and Ruygrok, P.A. (1981), "Wave Propagation in Porous Media, Shock Tube Experiments," Proceedings of the Xth International Conference on Soil Mechanics and Foundation Engineering, Stockholm, June 15-19, Vol. 3, pp. 253-256.
- Veyera, G.E. and Charlie, W.A. (1987), "Liquefaction of Shock Loaded Saturated Sand," Soil Dynamics and Liquefaction, Developments in Geotechnical Engineering 42, Elsevier, from 3rd International Conference on Soil Dynamics and Earthquake Engineering, Princeton, N.J., June 22-24, pp. 283-297.
- Whitman, R.V. and Ishihara, K. (1981), "Soil Dynamics - General Report (Preliminary)," Proceedings of the Xth International Conference on Soil Mechanics and Foundation Engineering, Stockholm, June 15-19, Supplementary Volume, General Reports, State-of-the-Art Reports, and Lectures, pp. 127-140.
- Woods, R.D. (1978), "Measurement of Dynamic Soil Properties," Proceedings of the Earthquake Engineering and Soil Dynamics Conference, ASCE, Pasadena, CA, Vol. 1, June 19-21, pp. 91-178.
- Woods, R.D. (1986), "In Situ Tests for Foundation Vibrations," Use of In Situ Tests in Geotechnical Engineering, Geotechnical Special Publication No. 6, Proceedings of an ASCE Specialty Conference, Virginia Tech, Blacksburg, VA, June 23-25, pp. 336-375.
- Woods, R.D. and Stokoe, K.H. Jr. (1985), "Shallow Seismic Exploration in Soil Dynamics," RICHART COMMEMORATIVE LECTURES, Proceedings of a session sponsored by the Geotechnical Engineering Division, in conjunction with the ASCE Convention Detroit, MI, Oct. 23, pp. 120-156.
- Yamamoto, T.; Turgut, A. and Trevorrow, M. (1989), "Seabed Shear Modulus Profiles Using a Gravity Wave Inversion," Proceedings of the Twelfth International Conference on Soil Mechanics and Foundation Engineering, Rio de Janeiro, Aug. 13-18, Vol 1, pp 359-362.
- You, Z.X. and Chang, N.Y. (1991), "Effects of Repeated Rotation of Principal Stress Directions on Cyclic Behavior of Monterey No. 0 Sand," 2nd ICRAGEE&SD.
- Yu, P. and Qin, W. (1991), "Dynamic Properties of Fly Ashes," 2nd ICRAGEE&SD.

Zen, K and Higuchi, Y. (1984), "Prediction of Vibratory Shear Modulus and Damping Ratio for Cohesive Soils," Proceedings of the 8th World Conference on Earthquake Engineering, San Francisco, July 21-28, Vol III, pp. 23-30.

Zimmie, T.F. and Normandeau, D.E. (1991), "The Effect of the Frequency of Cyclic Loading on San Fernando Sandy Silt," 2nd ICARGE&SD.