

13 Mar 1991, 1:30 pm - 3:30 pm

## Experimental Studies on an Embedded Soil-Structure Interaction in a Case of Hard Supporting Ground

Tomoyuki Inukai  
*Takenaka Corporation, Japan*

Masanori Izumi  
*Tohoku University, Japan*

Tamio Imazawa  
*Takenaka Corporation, Japan*

Eisuke Tanimoto  
*Nuclear Power Engineering Test Center, Japan*

Follow this and additional works at: <https://scholarsmine.mst.edu/icrageesd>



Part of the [Geotechnical Engineering Commons](#)

---

### Recommended Citation

Inukai, Tomoyuki; Izumi, Masanori; Imazawa, Tamio; and Tanimoto, Eisuke, "Experimental Studies on an Embedded Soil-Structure Interaction in a Case of Hard Supporting Ground" (1991). *International Conferences on Recent Advances in Geotechnical Earthquake Engineering and Soil Dynamics*. 18. <https://scholarsmine.mst.edu/icrageesd/02icrageesd/session05/18>

This Article - Conference proceedings is brought to you for free and open access by Scholars' Mine. It has been accepted for inclusion in International Conferences on Recent Advances in Geotechnical Earthquake Engineering and Soil Dynamics by an authorized administrator of Scholars' Mine. This work is protected by U. S. Copyright Law. Unauthorized use including reproduction for redistribution requires the permission of the copyright holder. For more information, please contact [scholarsmine@mst.edu](mailto:scholarsmine@mst.edu).

# Experimental Studies on an Embedded Soil-Structure Interaction in a Case of Hard Supporting Ground

Tomoyuki Inukai  
Research Engineer, Takenaka Corporation, Japan

Masanori Izumi  
Professor, Department of Architecture, Tohoku University, Japan

Tamio Imazawa  
Research Engineer, Takenaka Corporation, Japan

Eisuke Tanimoto  
Technical Department, Nuclear Power Engineering Test Center, Japan

**SYNOPSIS :** In order to investigate the embedment effects exerted on the vibration behavior of reactor buildings, a series of tests is being carried out employing the use of a large-scale test model constructed on hard ground. This paper describes the embedment effects obtained from the forced vibration tests, for the following items; 1) dynamic characteristics of soil-structure interaction system, 2) dynamic ground impedance, 3) soil pressure and so on.

## INTRODUCTION

With regard to nuclear reactor buildings, a part or the greater parts of the building are usually embedded in the ground due to the condition of the site, or the layout of the plant. It is an important subject from the view point of a seismic design to accurately understand how the embedment of the building has an influence upon the vibration characteristics. The embedment effects on dynamic soil-structure interaction are as follows: "increase of radiational damping", "increase of soil spring constant" and "variation of effective input motion".

In recent years, the experimental and analytical studies regarding the embedment effects have been forwarded and the basic data necessary for a seismic design are accumulated. However, there have been few examples in which a study concerning the embedment effects through forced vibration test or earthquake observation using a large scale model constructed on actual ground is conducted.

Both the forced vibration tests and the earthquake observations were planned and carried out since 1986 using a large-scale test model constructed on actual ground. The objectives of the test are understanding the embedment effects on dynamic soil-structure interaction problem, and accumulating the data required for the improvement of earthquake-proof performance. This paper will report on the results obtained from the forced vibration tests completed.

## TESTING METHOD

### Test Model and Soil Conditions

The large-scale test model is a reinforced concrete frame structure with shear walls constructed on the hard rock site with a shear wave velocity ( $V_s$ ) of about 1000m/sec. This test model with a height of 10m was designed as a model of the PWR type reactor buildings constructed in Japan. The non-dimensional frequency  $a_0$  for the foundation width of  $b$  is approximately 0.5 ( $a_0 = \omega_n \cdot b / V_s$

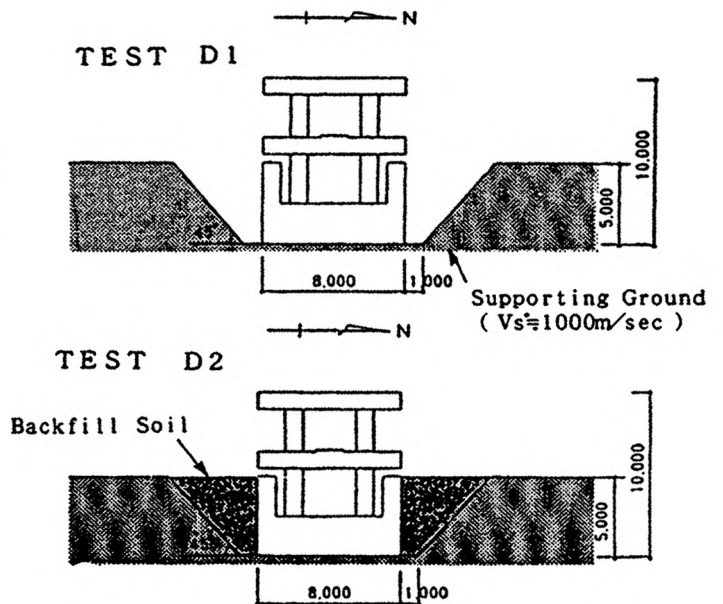

Fig. 1 D-Test Models

where  $\omega_n$ : natural circular frequency of soil-structure interaction system). The total weight of this test model is about 920ton. In order to investigate the embedment effects, Test D1 which was not embedded was conducted in 1988, and Test D2 employing the same model embedded in a depth of 5m was conducted next year. Figure 1 shows the test models. The backfill work was carried out by hopper, spread uniformly by hand and subjected to compaction. Each layer thickness for once work is 15 cm and the target shear wave velocity is about 130 m/sec (125-135m/sec).

### Forced Vibration Test

As the forced vibration test, sinusoidal wave steady-state excitation was conducted by each frequency through use of exciter. The frequency range for excitation was from 1Hz to 33Hz, and the frequency pitch was set to 0.1~0.2 Hz. The eccentric moment of exciter was properly set within 60~400kg·cm so that the backfill soil and the surrounding ground were within linear condition. The exciter was installed on the top floor of the model (RF-excitation) or the upper side of the foundation (BF-excitation).

### Measuring Method

The measurements were carried out in order to obtain the following data:

- 1) Displacement of the test model
- 2) Displacement of the backfill soil and the surrounding ground
- 3) Soil pressure of both the bottom and the side of the foundation
- 4) Acceleration in the backfill soil and the surrounding ground

The measurements in a steady-state were made for the response amplitude and the phase-lag from the exciting force. The location of the measurement points is mapped in Figure 2 to Figure 4. Table 1 shows the number of the measurement point.

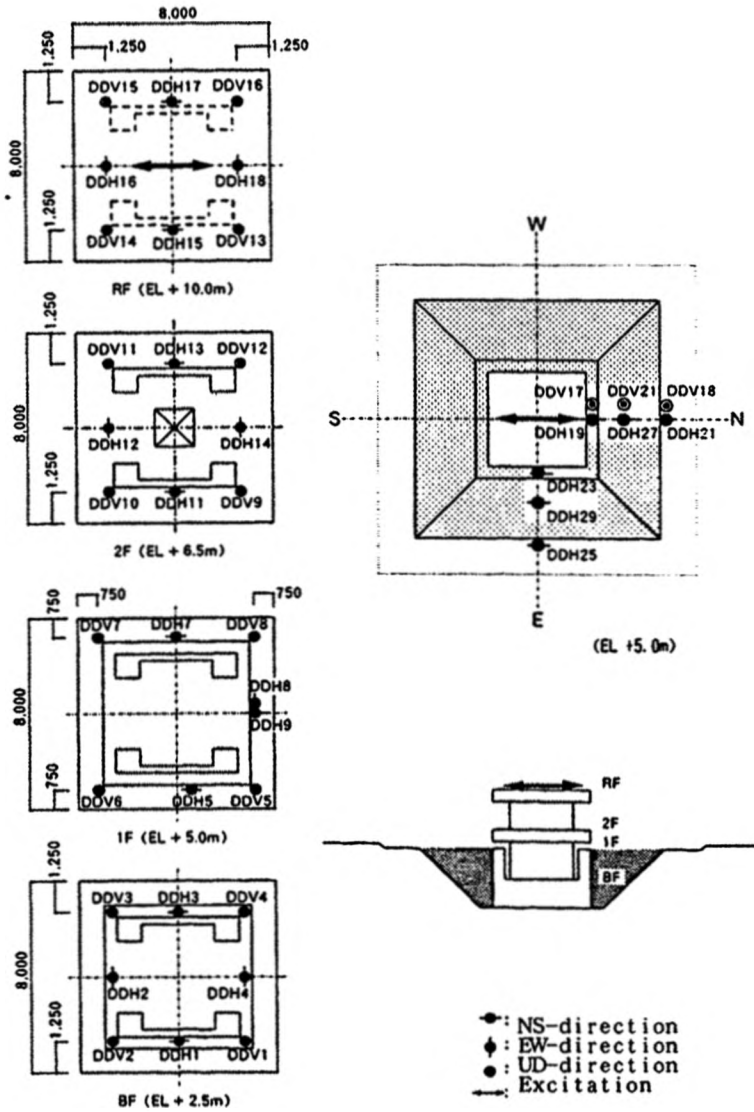

Fig. 2 Location of Displacement Measuring Points (D2 - RF - NS)

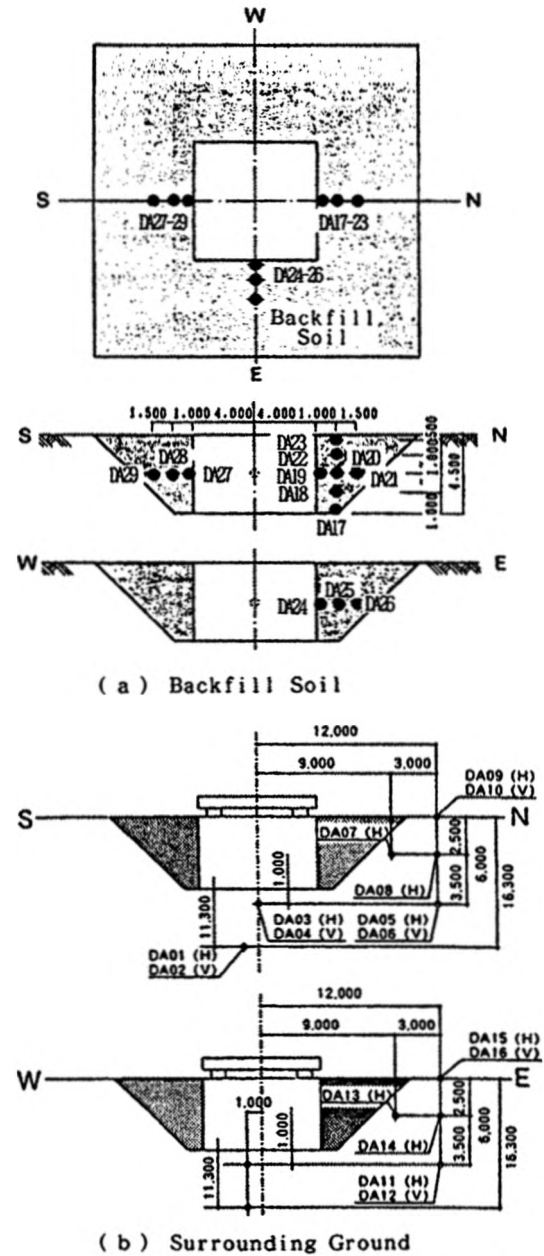

Fig. 3 Location of Acceleration Measuring Points

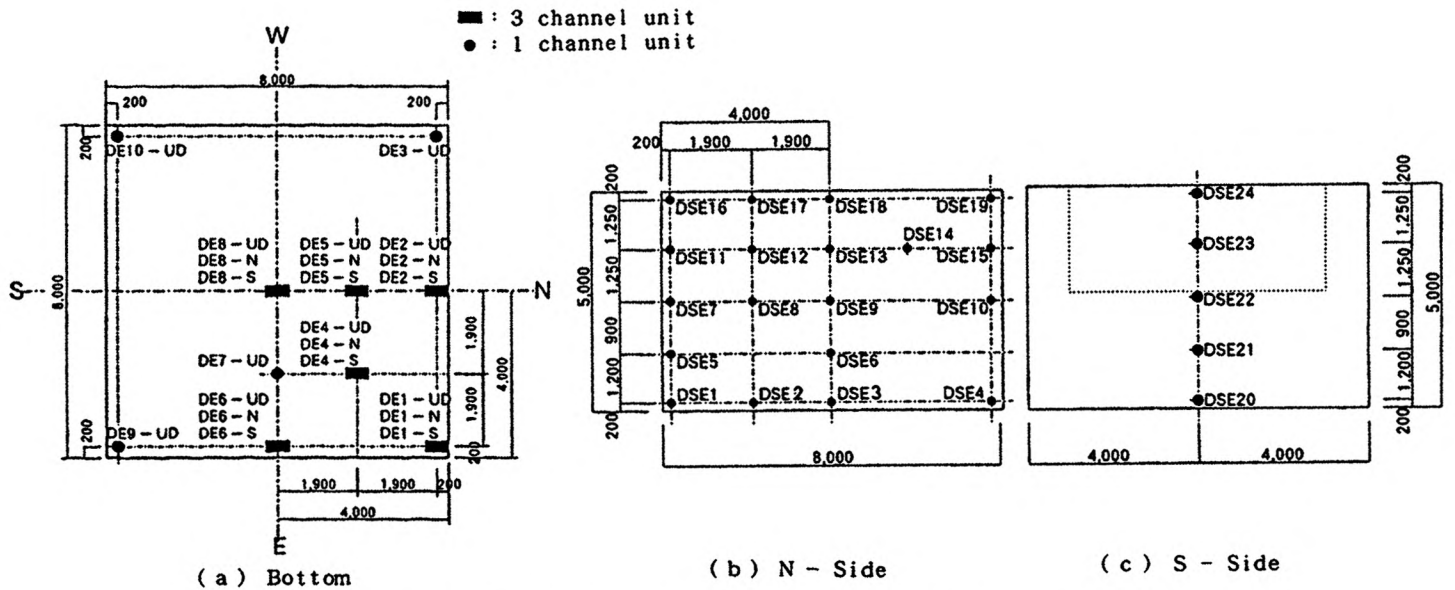

Fig. 4 Location of Soil Pressure Measuring Points

Table 1 Number of Measuring Point (Test D2)

Test	Location of Exciter	Direction of Excitation	Displacement (Model & Ground)			Soil Pressure		Acceleration			Total
								Surrounding Soil		Backfill Soil	
			NS	EW	UD	Bottom	Side	NS	UD	NS	
D2	RF	NS	15	7	19	22	24	10	6	13	116
	BF	NS	15	7	19	22	24	10	6	13	116
	RF	EW	7	15	19	10	0	0	6	0	57

Table 2 Dynamic Characteristics at Natural Frequencies

Test	Location of Exciter	Direction of Excitation	Order	Natural Frequency (Hz)	Damping Factor $\phi$	Contribution Ratio				
						Meas. Point	Disp ( $\mu$ /ton)	Sway $\%$	Rocking $\%$	Deform $\%$
D 1 Embedment 0 m	R F	N S	1st	11.0	1.9	R F	206.7	9	41	50
						B F	39.8	47	53	--
		E W	1st	8.4	1.1	R F	540.0	5	25	70
						B F	60.0	44	56	--
	B F	N S	1st	11.0	1.9	R F	39.1	9	41	50
						B F	7.5	47	53	--
D 2 Embedment 5 m	R F	N S	1st	11.3	4.4	R F	83.0	10	38	52
						B F	15.9	49	51	--
		E W	1st	8.65	1.5	R F	346.0	5	21	74
						B F	35.8	49	51	--
	B F	N S	1st	11.3	4.5	R F	6.3	--	--	--
						B F	2.0	--	--	--
B F	N S	1st	11.3	4.5	R F	15.3	10	39	51	
					B F	3.0	50	50	--	

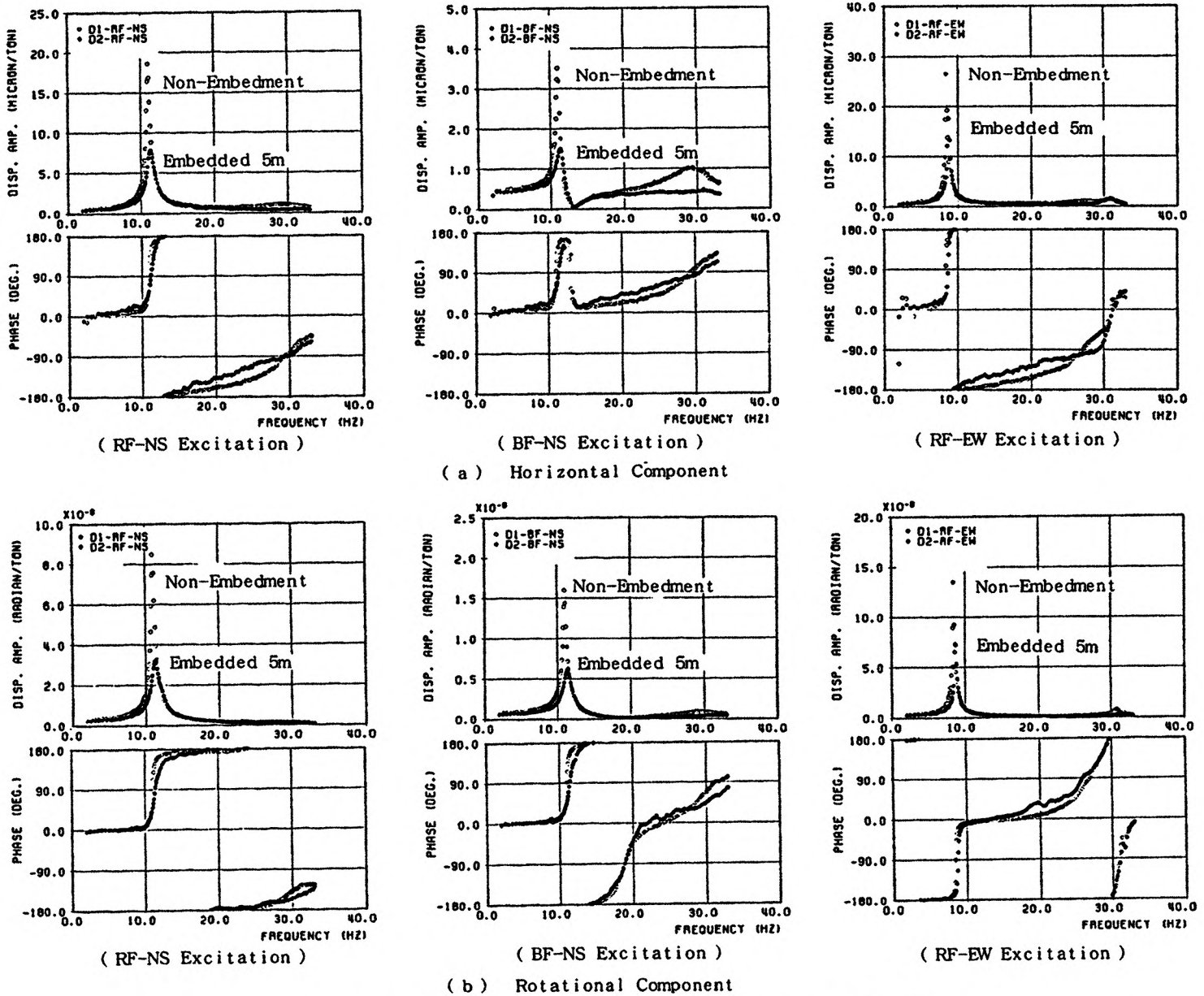

Fig. 5 Resonance Curves of Displacement at Center of Bottom  
(Comparison between D1 and D2)

## TEST RESULT

### Response of the Test Model

Table 2 shows the vibration characteristics of the test model at the natural frequencies obtained from the horizontal component of the resonance curve at RF. The resonance curves of the displacement at the center of the model foundation base, which is shown in Figure 5, indicate the difference of the test results obtained from the embedded case (Test D2) and the non-embedment case (Test D1). Figure 6 shows the comparison of the sway-rocking ratio at the center of the base. For the embedment effects exerted upon the vibration behaviors of the test model supported on the hard rock site, the followings can be clarified from the results mentioned above:

- 1) The resonance amplitude of the model for a unit force decreases to a large extent in both NS and EW directions. However, the natural frequencies of this interaction system does not change so much.
- 2) Due to the fact that the radiational damping effect is added from the side wall of the model in the embedded case, the damping factor at the natural frequencies increases. This tendency is found to be predominate in NS direction.
- 3) The test model used in the D-test series is supported on the hard ground. And the contribution ratio of the super-structure elastic deformation at the natural frequency is high. Therefore, the change in

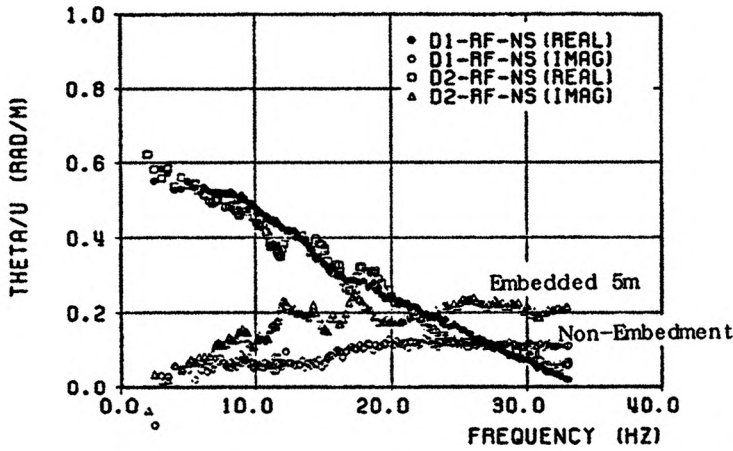
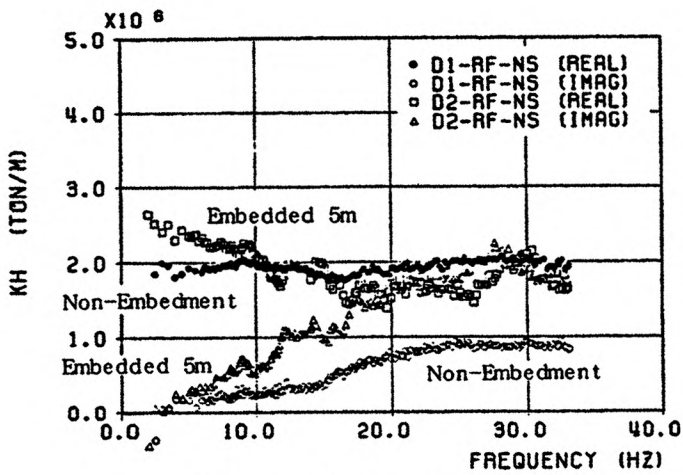
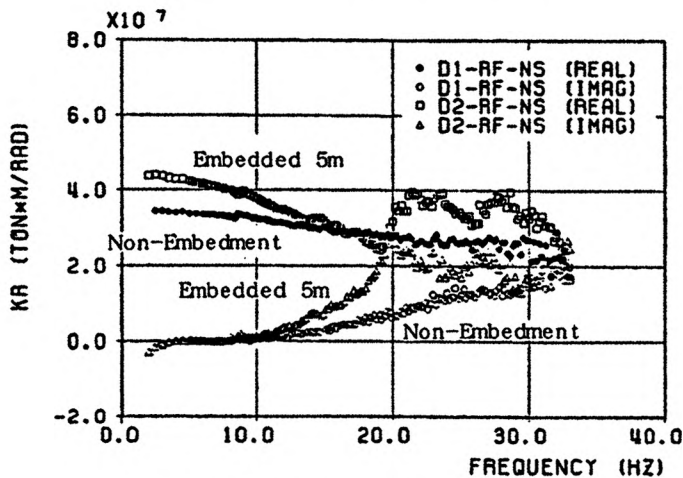

Fig. 6 Sway-Rocking Ratio at Bottom  
(Comparison between D1 and D2)



(a) Horizontal Component



(b) Rotational Component

Fig. 7 Dynamic Ground Impedance  
(Comparison between D1 and D2)

- the displacement contribution ratio at the top of the model induced by embedment is small.
- 4) The differences of the sway-rocking ratio at the model bottom caused by embedment, are found only at the imaginary part.
- 5) In the vicinity of the natural frequency, the gradient of the phase-lag curves become gentle corresponded to that the damping ratio increase due to the embedment effects.
- 6) In the embedded case, some elastic waves propagate through the backfill soil. Due to this, the resonance curves of the test model change slightly depending on the frequency.

Dynamic Ground Impedance

Figure 7 shows the comparison of the dynamic ground impedances between Test D1 and Test D2. The comparison is made in the case of the NS direction excitation at RF. From the figures, the followings are clarified:

- 1) With regard to the impedance, it is recognized that the stiffness increases with in low frequency range in both the horizontal and rotational component due to the binding effect of backfill soil. However, due to the wave propagation through the backfill soil, there are a few cases where the stiffness becomes rather small compared with the non-embedment case.
- 2) The imaginary part, which indicates the radiational damping effect, increases because of the embedment. This tendency is outstanding in the horizontal component of the impedance.

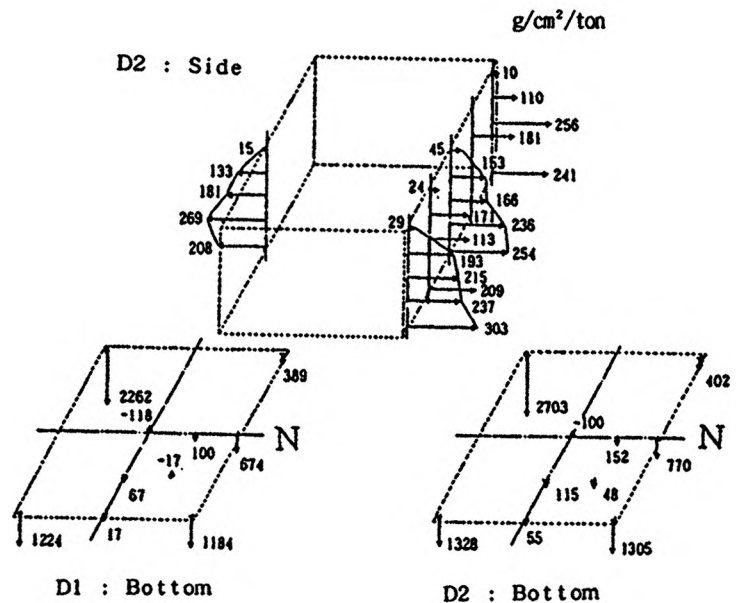

Fig. 8 Static Soil Pressure Distribution

Static and Dynamic Soil Pressure

Figure 8 shows the static soil pressure distribution on the bottom and side of the test model in the case of D1 (non-embedment) and D2 (embedded 5m). The soil pressure on the bottom obtained from the total weight of the model, under the assumption of homogeneous distribution is 1440g/cm<sup>2</sup>. The simple average values obtained from the results of D1 and D2 tests were 578g/cm<sup>2</sup> and 678g/cm<sup>2</sup> respectively. The values don't correspond very well to each other due to inevitable difficulty for installation of soil pressure cell in the hard ground. The distribution shapes of the static soil pressure are close to that of the rigid plate assumption, and the value is small at the NW corner. The static soil pressure value on the side of the test model has to increase accordingly to the depth. The side soil pressure at a depth of 5m comes to 450g/cm<sup>2</sup>, as the static soil pressure coefficient is fixed at 0.5. However, the value obtained from the result of D2 is 303g/cm<sup>2</sup> at a maximum, which is relatively small.

Figure 9 indicates the comparison of the resonance curves of the vertical component of the dynamic soil pressure on the bottom between D1 and D2. The dynamic soil pressure distributions of the bottom and the side at the natural frequency for D1 and D2 are shown in Figure 10.

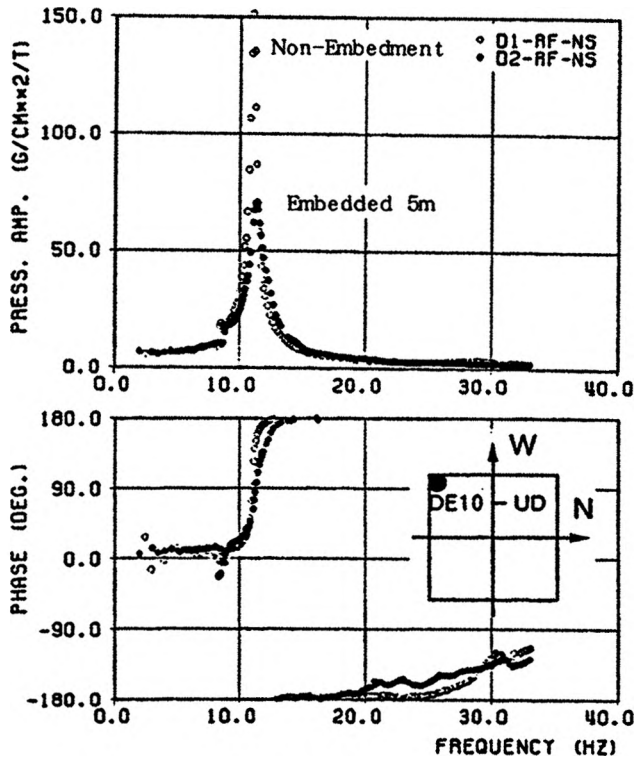
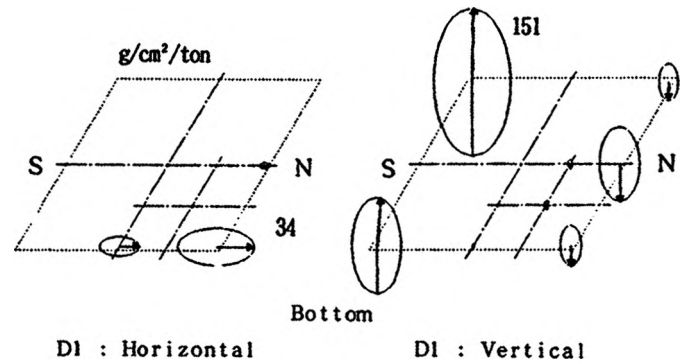

Fig. 9 Resonance Curves of Soil Pressure (Comparison between D1 and D2)

From the results mentioned above, it is recognized that the difference of the dynamic soil pressure distribution shapes on the bottom caused by the embedment is small, although the response amplitude decrease according to the vibration behavior of the test model. The shapes of the dynamic soil pressure distribution at the natural frequency is close to that of the rigid plate assumption. The dynamic soil pressure distribution on the side has a tendency to become large near the surface of backfill soil in accordance with the rocking motion. Since the test model is directly supported on the hard ground, the soil pressure reaction for the total inertia force of the model induced at the natural frequency is shared mostly by the vertical component on the bottom.



Bottom

D1 : Horizontal

D1 : Vertical

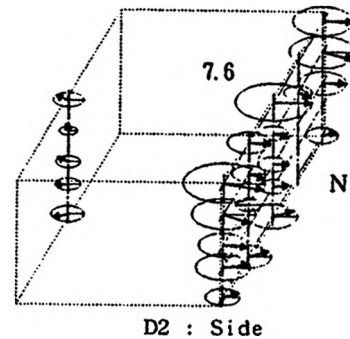

D2 : Side

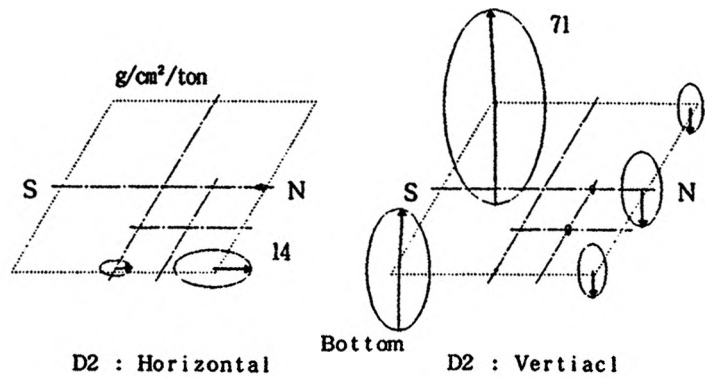

D2 : Horizontal

D2 : Vertical

Fig. 10 Dynamic Soil Pressure Distribution

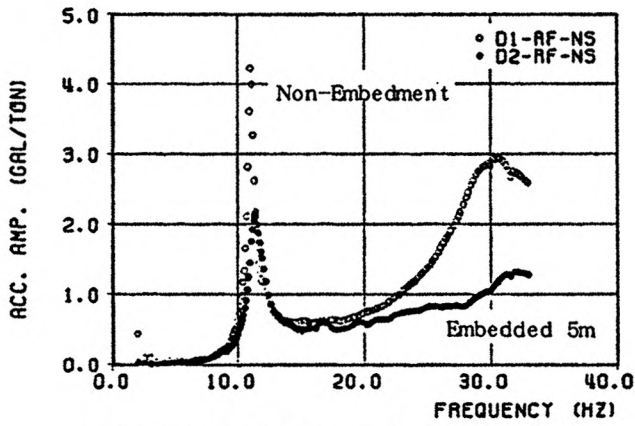

(a) Just Below the Model (DA03)

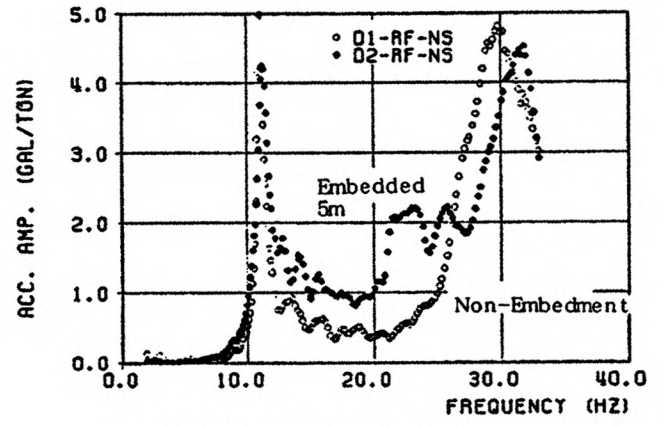

(b) Top of Slope (DA09)

Fig. 11 Resonance Curves of Surrounding Ground (Comparison between D1 and D2)

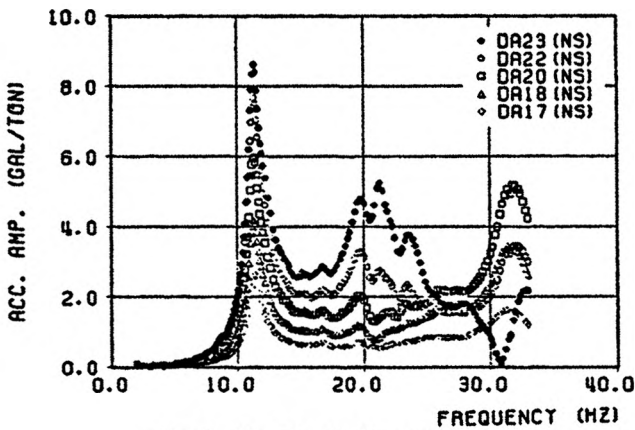

(a) Vertical Direction

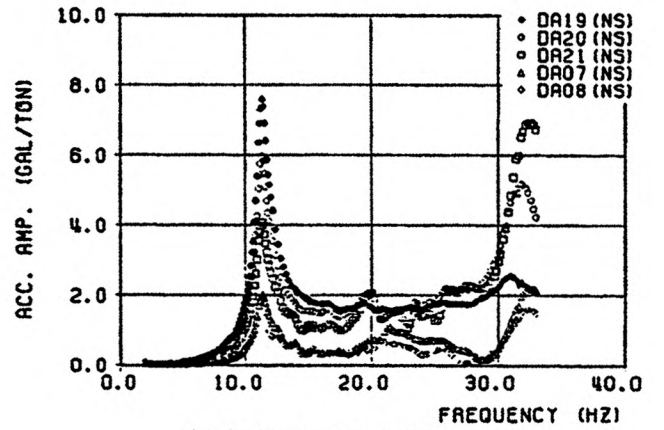

(b) Horizontal Direction

Fig. 12 Resonance Curves of Groud (Test D2)

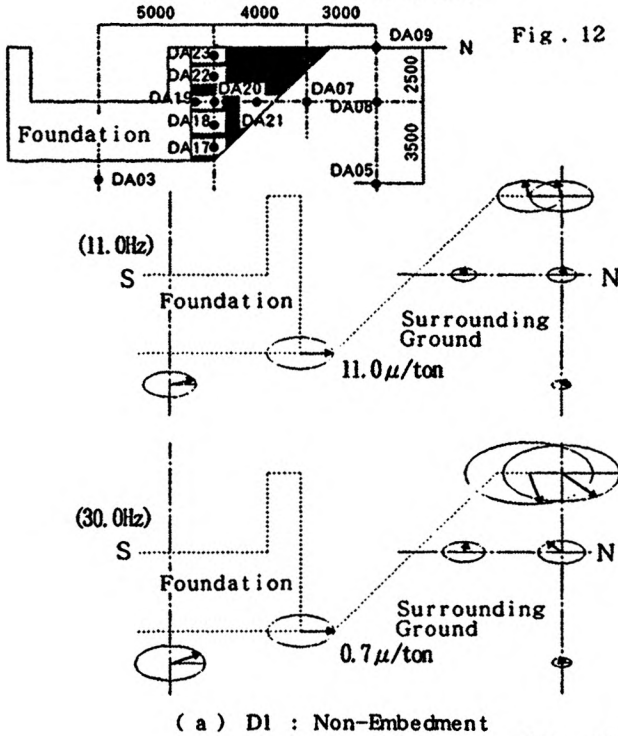

(a) D1 : Non-Embedment

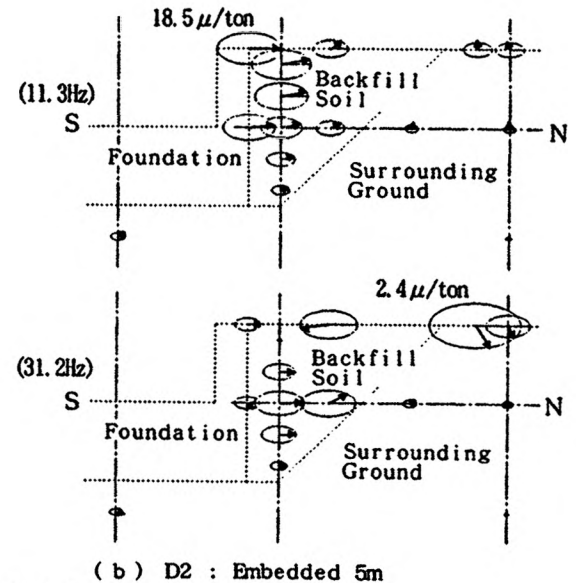

(b) D2 : Embedded 5m

Fig. 13 Mode Shape of Groud



## Backfill Soil and Surrounding Ground

Figure 11 shows the comparison of the acceleration resonance curves of the surrounding ground between D1 (non-embedment) and D2 (embedded 5m). Figure 12 indicates the resonance curves of the backfill soil and the surrounding ground in the case of D2. In these figures, (a) shows a trend in vertical direction according to the measuring disposition and (b) shows the horizontal direction respectively. The vibration modes are shown in Figure 13, where the values of the displacement amplitude are converted from the measured acceleration amplitude.

From those results, the followings can be made clear:

- 1) The response tendency of the ground just below the test model corresponds to that of the model bottom behavior. And due to the embedment effects, the amplitudes of the ground at the resonant frequencies decrease.
- 2) The resonant frequency of the top of the slope at about 30Hz becomes high due to the binding effect of the backfill soil.
- 3) The amplitudes of the backfill soil increase as it nears the surface. And at nearly 20Hz, some peaks of the resonance curves caused by the resonance of backfill soil appear.

## CONCLUSIONS

From the results obtained from the forced vibration tests through the use of the large scale test model constructed on the actual hard ground, the following conclusions have come to light as the embedment effects which exert an influence upon the vibration behavior of the structures.

- 1) When a structure is supported on hard ground and the vibration behavior of the upper structure becomes prominent, the change of the natural frequencies by the embedment effects is small. However, the amplitude for the unit excitation force at the resonant frequencies greatly decreases due to the embedment effects.
- 2) The real part of the dynamic ground impedance, which represents the stiffness, increases within the low frequency range due to the embedment effects. While the imaginary part indicating the radiation-damping effects increases due to the embedment. This tendency is remarkable in the horizontal component.
- 3) In the case of the structure constructed on the hard ground, the total inertia force of the structure at the natural frequency is shared mostly by the vertical component of the soil pressure at the structure bottom.
- 4) The distribution shapes of both the static and the dynamic soil pressure are close to that of the rigid plate assumption.

In the future, in order to reflect the embedment effects which exert influence upon the dynamic ground impedance on a seismic design, an analytical study for the forced vibration tests, described in this paper, will be carried out.

## ACKNOWLEDGEMENT

This work was carried out as the entrusted project sponsored by the Ministry of International Trade and Industry in Japan. This work was supported by "Sub-Committee of Model Tests on Embedment Effect on Reactor Building" under "Committee on Seismic Verification Test" of Nuclear Power Engineering Test Center. The authors wish to express their gratitude for the co-operation and valuable suggestions given by the members of committee.

## REFERENCES

- Izumi, M et al., "Model Tests on Embedment Effect on Reactor Building - Field Test (Part 1 - 5)", Summaries of Annual Meeting AIJ, 1989, vol. C, 1065-1074, (in Japanese)
- Izumi, M et al., "Model Tests on Embedment Effect on Reactor Building - Field Test (Part 7 - 12)", Summaries of Annual Meeting AIJ, 1990, vol. C, (Submitting), (in Japanese)