



Missouri University of Science and Technology  
Scholars' Mine

---

International Conference on Case Histories in  
Geotechnical Engineering

(1984) - First International Conference on Case  
Histories in Geotechnical Engineering

---

11 May 1984, 8:00 am - 10:30 am

## Construction of the Key Lake Tailings Facility

R. B. Knight

*Knight and Piesold Ltd., Consulting Engineers, Vancouver, Canada*

J. P. Haile

*Knight and Piesold Ltd., Consulting Engineers, Vancouver, Canada*

Follow this and additional works at: <https://scholarsmine.mst.edu/icchge>

 Part of the [Geotechnical Engineering Commons](#)

---

### Recommended Citation

Knight, R. B. and Haile, J. P., "Construction of the Key Lake Tailings Facility" (1984). *International Conference on Case Histories in Geotechnical Engineering*. 8.

<https://scholarsmine.mst.edu/icchge/1icchge/1icchge-theme9/8>

This Article - Conference proceedings is brought to you for free and open access by Scholars' Mine. It has been accepted for inclusion in International Conference on Case Histories in Geotechnical Engineering by an authorized administrator of Scholars' Mine. This work is protected by U. S. Copyright Law. Unauthorized use including reproduction for redistribution requires the permission of the copyright holder. For more information, please contact [scholarsmine@mst.edu](mailto:scholarsmine@mst.edu).

# Construction of the Key Lake Tailings Facility

**R. B. Knight**

President, Knight and Piesold Ltd., Consulting Engineers, Vancouver, B.C.

**J. P. Haile**

Director, Knight and Piesold Ltd., Consulting Engineers, Vancouver, B.C.

**SYNOPSIS** Construction of the Tailings Storage Facility for the Key Lake Project, a major uranium mine in northern Saskatchewan, Canada, was completed in June, 1983. Principal design features of the tailings facility are an underseal and underdrainage system over the entire area, systematic deposition of the tailings in thin layers using the sub-aerial technique, and continuous removal and recycling of all surface water and underdrainage outflows to the mill for treatment. These features are designed to achieve a consolidated, drained tailings deposit suitable for immediate decommissioning on completion of milling, and with a minimal potential of long term seepage. The design has used naturally occurring materials as far as possible, with the underseal constructed by modification of the natural till with imported bentonite. Design requirements, specifications and quality control procedures during construction are described, together with initial deposition of the tailings slurry.

## INTRODUCTION

The Key Lake Project is a major uranium mine and mill complex located in northern Saskatchewan, Canada. The project site is located approximately 240 km north of La Ronge on the southern boundary of the Athabasca Sandstone Formation. The area is typified by undulating hills and drumlins, and numerous small lake-filled depressions. Vegetation is generally stunted spruce and jackpine typical of sub-arctic regions. Mean annual precipitation and potential evaporation for the site are 460 mm and 508 mm respectively.

The uranium at Key Lake is contained in two orebodies located at the sandstone basement contact beneath extensive deposits of outwash sands, at depths of up to 100 metres. The orebodies have an average grade of approximately 2.5%  $U_3O_8$ , and are associated with high percentages of Nickel and Arsenic. (Clarke et. al. (1980)) Principal environmental concerns for the tailings facility were concentrated on potential leaching of the Nickel, Arsenic and Radium in the tailings, and resulting on-going seepage into the surrounding environment. The principal design objectives of the facility were therefore to achieve a system whereby seepage discharge to the environment will be reduced to negligible proportions during operation, and the tailings will be fully drained and consolidated at decommissioning such that immediate construction of a surface seal will eliminate any long term seepage.

The principal design features of the tailings storage facility are as follows:

- (i) The base of the entire facility is covered by underseal constructed to grades by modification of the natural till material with bentonite. Overlying the underseal is a sand filter blanket and perforated drainage pipe system to intercept and remove all vertical seepage from the tailings.

- (ii) The tailings slurry is deposited over the filter blanket in thin layers from a spray-bar system to produce a tailings beach sloping towards the main embankment. This 'sub-aerial' deposition enhances liquid solid separation and produces a laminated tailings deposit with a low coefficient of vertical permeability, and a high runoff coefficient for precipitation.
- (iii) The main embankment incorporates a pervious upstream zone to continuously decant supernatant water from the tailings beach. A pump station outside the main embankment recycles the supernatant water and underdrainage outflows to water reservoirs at the plant site, where the water is treated prior to release to the environment.
- (iv) At decommissioning a surface seal will be constructed over the tailings and the underdrainage system will serve as a monitoring system for long term seepage, should any appear.

A schematic section through the tailings storage facility is given in Fig. 1. A detailed description of sub-aerial tailings deposition and the design concepts of the tailings storage facility for the Key Lake Project, and for another project, have been previously presented by Knight and Haile (1983).

Construction of the Key Lake tailings facility was started in March 1982 and completed in June 1983, with mine start-up and initial tailings deposition in September, 1983.

## CONSTRUCTION MATERIALS AND SPECIFICATIONS

The tailings facility is located approximately 1.5 km west of the mill site on a broad ridge

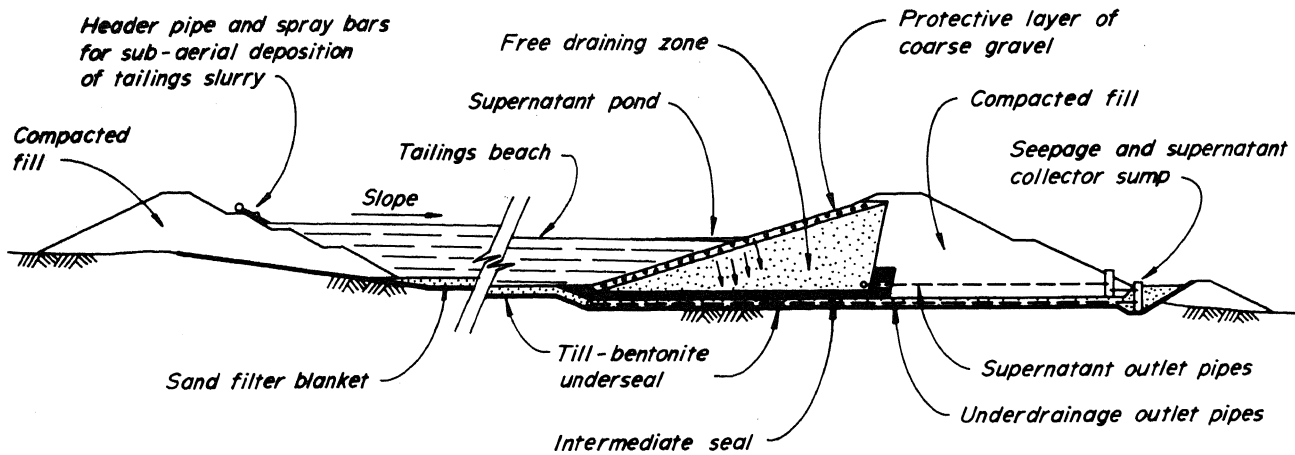

Fig. 1. Schematic Section through Tailings Storage Facility

with a slope of approximately 2 percent towards the north-east. The general stratigraphy over the area consists of medium dense to very dense sandy till overlying sandstone at an average depth of 8 metres, which in turn overlies the crystalline basement of granitic gneiss.

A site investigation program was carried out to define the general site conditions, and included detailed investigation of geological, hydrogeological and geotechnical conditions. The scope of work included the following:

- 4 diamond drill holes to investigate two geophysical anomalies beneath the proposed facility.
- 12 hydrogeological boreholes to define bedrock stratigraphy and hydrogeological conditions.
- A comprehensive series of test trenches and test pits for overburden classification and sampling for detailed geotechnical testing.

The till overburden material is fairly consistent throughout the site with an average gradation of 30 percent gravel, cobbles and boulders, 60 percent sand and 10 percent silt and clay. The till forms the principal structural material in the construction of the tailings facility.

Overburden materials above the orebody, which were to be excavated in the first open pit development, had been investigated in detail in the design of the dewatering and mining plans. The material is generally a clean outwash sand interbedded with occasional silt lenses, with an increasing gravel content with depth. With selective excavation, large quantities of the open pit overburden material were available and suitable for use in the tailings facility as a filter blanket and in drainage zones.

The design of the underseal and intermediate seal for the facility required the use of naturally occurring materials for long-term durability, with an objective for the coefficient of permeability of  $1 \times 10^{-9}$  m/s for adequate control of

initial vertical seepage from the tailings. No naturally occurring clay materials were available near the project site and, after suitable testing, it was decided to import commercial bentonite from a source near Regina, Saskatchewan, approximately 750 km to the south. Laboratory testing indicated that the design permeability objective could be achieved by blending in approximately 3 percent bentonite with the natural till material. Further testing was carried out to study the chemical compatibility of the bentonite underseal with the gypsum saturated seepage solutions from the tailings. No adverse effects were indicated.

Geotechnical parameters for the basic construction materials are summarised in Table I.

TABLE I. Construction Material Parameters

Material	Compaction		Strength		Permeability k (m/s)
	ASTM Test	$\gamma_d$ max. (t/m <sup>3</sup> )	opt. m/c (%)	c' $\phi'$	
Till	D2049	2.09	-	0 42.4+ 0 41.5++	$3 \times 10^{-6}$
Sand	D2049	1.89	-	0 35.0x	$4 \times 10^{-4}$ *
Till/ Bentonite	D1557	2.13	6.7	-	$< 1 \times 10^{-9}$ **

All compaction tests on minus 20 mm fraction.

- + Consolidated Undrained Triaxial Test
- ++ Consolidated Drained Triaxial Test
- x Shear Box Test
- \* Compound pump test on open pit overburden
- \*\* Design objective (Approximately 3 percent bentonite)

Specifications for materials handling during construction, while being too extensive for detailed coverage in this paper, were based on a method specification, with detailed descriptions of required materials handling procedures. Control of layer thickness, compaction passes, bentonite addition, moulding moisture content, and

selection of sand overburden excavated from the open pit, was retained directly by the Consultant, and specified on an on-going basis. In particular, the following procedures were specified for construction of the underseal and intermediate seals:

- level and grade till overburden to the required final profiles, removing plus 100 mm oversize particles,
- spread the bentonite using a mechanical spreader at the designated application rate,
- blend in the bentonite to a depth of 200 mm using a pulvimixer prior to any water addition,
- moisture condition the blended till bentonite with a minimum of 2 passes of the pulvimixer with water addition,
- level using a grader, and compact with the specified number of passes using a 10 tonne smooth drum vibrating roller.

Specific procedures were developed for calculation of the bentonite application rate and moulding moisture content on the basis of standard laboratory control tests, which are described in the following section.

Density objectives for the fill material and underseal were 95% of maximum density as determined by ASTM D2049 and D1557, respectively. In general, 8 passes of the specified rollers were required to achieve these objectives throughout the progress of the work.

A summary of the basic material quantities for the work is given in Table II.

TABLE II. Summary of Material Quantities

Type	Location	Unit	Quantity
Fill Material	Embankments	m <sup>3</sup>	1,650,000
Filter Material	Filter Blanket	m <sup>3</sup>	300,000
	Main Embankment	m <sup>3</sup>	350,000
Coarse Filter Material	Main Embankment	m <sup>3</sup>	20,000
Till/Bentonite	Intermediate Seal	m <sup>3</sup>	60,000
	Underseal	ha	50
Bentonite	Intermediate Seal plus Underseal	t	10,000

#### QUALITY CONTROL ON UNDERSEAL

Construction of the underseal constituted the most important component of the overall construction program. In the design stage of the work it was recognised that some variability in the material to be modified with bentonite would be encountered, and hence a procedure was developed for designating bentonite application rates on the basis of a modified Proctor compaction test (ASTM D1557 Method D) on the base material. The procedure was also required for similar un-

derseals, which included a leak detection system beneath the water storage reservoirs and under-drainage systems beneath the ore stockpiles, constructed elsewhere on the site.

The procedure used was as follows:

- (i) Calculate the porosity of the base material at the maximum D1557 density:
- (ii) By introducing a 'swell factor',  $s$ , and allowing for the density of dry bentonite as approximately equal to 1 t/m<sup>3</sup>, calculate the weight of bentonite per unit volume required to fill the voids:

$$\text{wt. of bentonite} = \frac{n}{s} \times 1 \text{ (t/m}^3\text{)} \quad (1)$$

- (iii) For a 200 mm thickness of underseal, calculate the resulting application rate:

$$\begin{aligned} \text{Application rate} &= \frac{n}{s} \times .2 \times 1000 \\ &= \frac{200n}{s} \text{ (kg/m}^2\text{)} \quad (2) \end{aligned}$$

- (iv) Calculate the percentage bentonite addition on the basis of the maximum D1557 density:

$$\text{Bentonite addition} = \frac{n}{s} \times \frac{100}{\gamma_d \text{ max}} \text{ (%) } \quad (3)$$

On the basis of laboratory tests carried out on actual materials from the site, it was found that by ascribing a value of  $S = 4$ , permeability results of less than  $1 \times 10^{-9}$  m/s would be assured. This value of  $S$  was subsequently used during construction, with the intention of making suitable adjustments on the basis of results achieved. It is the authors' contention that a value of  $S$  equal to the Activity value of the clay (P.I./% minus 2 microns) can be used with the above procedure for determining an initial application rate for blended clay materials to achieve the design objective of  $k$  less than  $1 \times 10^{-9}$  m/s.

The designated moulding moisture content was determined, on the basis of the initial laboratory tests, as being that required to achieve 90% saturation at the maximum D1557 density:

$$\text{Moulding moisture content} = \frac{90n}{\gamma_d \text{ max}} \text{ (%) } \quad (4)$$

In practice this value worked out to be approximately the optimum moisture content plus 2 percent.

Record tests on completed areas of underseal comprised the following series of tests:

- In-situ density (water replacement method)
- Laboratory maximum density (ASTM D1557)

- In-situ permeability test
- Laboratory permeability test

The frequency of record tests was one set of tests for every 2500 m<sup>2</sup> of completed underseal.

Due to the low permeability of the compacted underseal, standard methods of permeability testing, such as the Earth Manual field permeability test (Designation E-36), were considered inappropriate for achieving any feedback into the construction operation. Therefore, in order to obtain accurate and reliable permeability test results in a short enough time period to allow for proper control of the construction operation, both in-situ and laboratory permeability tests were carried out using methods based on the air-entry permeameter suggested by Bouwer (1966).

The air-entry permeameter provides a means for rapid calculation of the coefficient of permeability, by measuring suction pressures influencing the initial rate of infiltration into unsaturated soils above the water table. A schematic diagram of the apparatus is shown on Fig. 2. Water is introduced into the sealed test ring and the infiltration rate measured on a graduated cylinder. After a sufficient period of time to allow the wetting front to advance approximately 1 cm, the water supply is closed off, and the resulting maximum suction pressure that develops within the apparatus is measured. This value yields the air-entry value,  $P_a$ , of the soil ( $P_a = P_{min} + G + L_f$ ), which is approximately twice the water-entry value, or suction pressure, at the wetting front (Bouwer (1978)). The coefficient of permeability can be calculated from the following equation:

$$k = \frac{(dV/dt) \cdot L_f}{A(H_r + L_f - 0.5 P_a)} \quad (5)$$

where  $\frac{dV}{dt}$  = the infiltration rate corresponding to  $L_f$

- A = area of the test ring
- $H_r$  = applied head
- $P_a$  = air-entry pressure of the soil
- $L_f$  = depth of the wetting front

Various procedures have been suggested for measuring the depth of the wetting front, by visual examination or pushing in a rod (Bouwer (1978)), or by using tensiometers (Topp and Binns (1976)). At Key Lake, none of these procedures were practical due to the very high compacted density of the seal material, and a procedure was adopted for calculating the advance of the wetting front on the basis of the total volume of water infiltrated, the measured porosity and the initial saturation of the soil. By assuming all infiltration travels only within the pore air spaces, a conservative (large) estimate of  $L_f$  was made.

Some difficulties were also experienced in effecting a good seal around the perimeter of the test ring for in-situ tests. For this reason laboratory air-entry permeameter tests were also carried out on samples brought directly from the field and compacted in a standard compaction

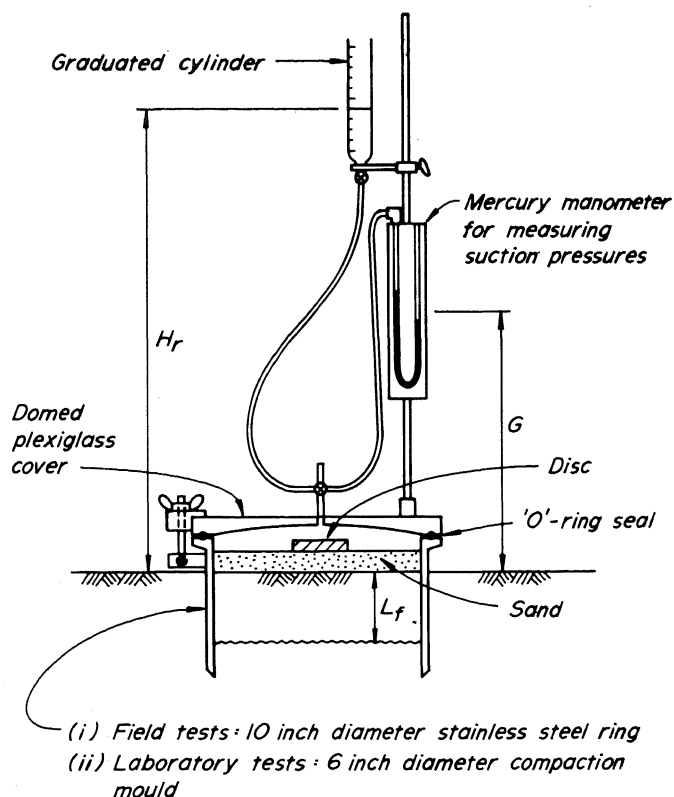

Fig. 2. Air-entry Permeameter

mould to the field density.

Additional permeability testing, carried out to verify the air-entry permeameter results, involved constant head tests on recompacted samples in a 6 inch diameter triaxial cell, and falling head tests on recompacted samples in a standard falling-head permeameter. Of all tests carried out, the triaxial tests were considered to be the most reliable.

Results of the permeability tests carried out on the underseal are shown on Fig. 3, with the exception of the in-situ air-entry permeameter tests. Of 133 in-situ tests carried out 35 tests gave results higher than the design objective of  $1 \times 10^{-9}$  m/s and were assumed to be associated with leaks around the perimeter of the test ring. With reference to Fig. 3, all laboratory air-entry tests gave results well below the design objective, the triaxial tests gave a median value of  $2.7 \times 10^{-10}$  m/s, and a single falling head test gave a value of  $5.1 \times 10^{-10}$  m/s.

The above results were achieved with an average bentonite addition of 3 % (12 kg/m<sup>2</sup>). The results could have been further improved, or bentonite addition reduced, by better control on moisture conditioning. Fig. 3 indicates a large proportion of test results with actual moisture contents below the average designated value of optimum plus 2 percent. The influence of increased moulding moisture content on permeability is

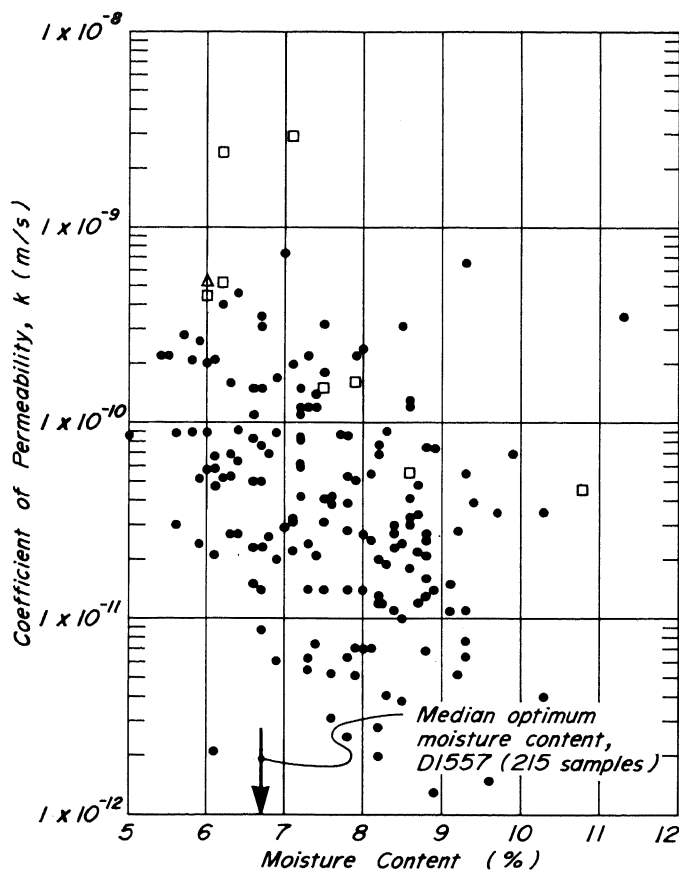

- Results of laboratory air-entry permeameter tests
- Results of laboratory triaxial cell tests
- △ Results of falling head permeameter test

Fig. 3. Results of Permeability Tests on Underseal

clearly shown by the pronounced trend of test results on Fig. 3.

Additional record tests on the underseal involved density testing and gradation analyses. Results of the density tests are summarised in Table III, and typical record test gradation analyses are shown in Fig. 4. In practice, the Contractor experienced difficulty in removing oversize (plus 100 mm) particles from the in-situ material and elected to screen out all plus 75 mm particles.

#### QUALITY CONTROL ON FILL AND FILTER MATERIALS

Fill material for the facility was obtained from the necessary excavations and from a designated borrow area immediately west of the facility. The material required conformance with a specified gradation envelope with a provision for a limited number of oversize particles in the fill, and the remainder being incorporated on the exposed outer faces of the embankments.

Fill material was placed in 300 mm horizontal lifts, spread and levelled with a motor grader, and compacted with the designated number of pas-

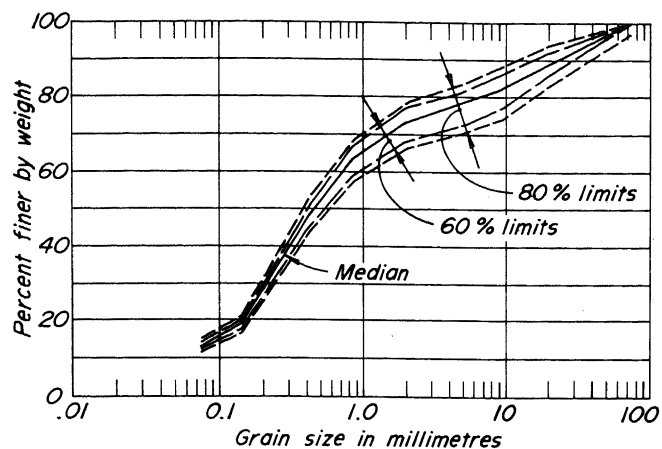

Fig. 4. Typical Record Test Gradation Analyses for Underseal (88 samples)

TABLE III. Underseal Density Test Results

Testing Period	No. of tests	Median field dry density+ (t/m <sup>3</sup> )	Mean % compaction* (%)	Standard deviation (%)	Coeff. of variation (%)
<b>1982</b>					
Jun/Jul	42	2.03	95.9	5.2	5.4
Aug	67	2.07	97.8	4.4	4.5
Sept	90	2.08	97.6	9.8	3.9
Oct	60	2.03	96.2	3.6	3.8
<b>1983</b>					
May/June	18	2.02	95.7	2.3	2.4

+ Minus 20 mm fraction.

\* based on maximum density by ASTM D1557 Method D.

ses of the specified compaction equipment. No moisture conditioning of the fill material was required although a maximum permissible moisture content of the material at placing of 8% was imposed. The number of passes of the compaction equipment was designated by the Consultant on the basis of record test results and general performance. Compaction time was paid for on the basis of actual hours worked as designated by the Consultant.

The specified equipment for normal compaction was a smooth drum vibratory roller with a total static weight of not less than 10 tonnes, and capable of developing a centrifugal force of not less than 18 tonnes at 1250 vibrations per minute.

Quality control testing for fill placing consisted of control tests, carried out on material prior to compaction to ensure compliance with material specifications, and record tests carried out on the compacted fill to measure the densities achieved, and to allow for on-going modifi-

cation of placing and compaction procedures.

Control tests for fill material consisted of gradation analyses and moisture content determinations on selected samples. Due to the consistently acceptable gradation and moisture content of the material established by frequent initial testing, the number of control tests carried out during the latter part of the work was minimal. The initial frequency of control test sampling was one test for every 4000 m<sup>3</sup> of material excavated.

Record tests for fill material consisted of in-situ measurements of field dry density and moisture content, laboratory determinations of maximum dry density and gradation analyses on the actual samples for each test.

Specified testing methods consisted of using a 350 mm diameter density ring and the water replacement method for field density measurements, and the vibrating table method for determination of laboratory maximum dry density (ASTM D2049). The field density objective was for a minimum of 95% of the laboratory maximum dry density. The frequency of record tests was one test for every 4000 m<sup>3</sup> of fill material placed.

A total of 390 fill record tests were taken during construction between April and October of 1982, and May and July of 1983. A summary of the results achieved is shown on Table IV. Gradation analyses of the fill material were in general very similar to Fig. 4 for the underseal, with the exclusion of the additional bentonite.

During the first three months of construction in 1982 the number of compaction passes was increased from 5 to 8 in response to low compaction results and poor layer thickness control in the field. The median percent compaction increased during this period from approximately 91%, equivalent to 96% using the D1557 method, to 99.5%. General quality control was somewhat erratic over the period, and was partially a result of variability of the fill material being placed.

From July through to the end of October 1982 the number of compaction passes was maintained at 8, and fairly consistent compaction was achieved, with monthly medians of percent compaction varying between 96.8% and 99.0%. Monthly coefficients of variation for field dry density, and percent compaction were consistently between 5 and 6, indicating reasonable quality control and fairly uniform fill material.

For the 1983 construction period, high densities were achieved on the fill material in the main embankment with monthly medians of percent compaction from May to July of 97.4%, 97.8% and 100.5%, respectively. The required number of compaction passes was maintained at 8, however, the Contractor generally applied additional passes throughout 1983 construction season. Monthly coefficients of variation for field dry density and percent compaction were consistently below 5, indicating fairly good quality control on the fill material.

Filter material for the tailings facility was obtained by selective excavation of the outwash sand overburden material during open pit deve-

lopment of the first orebody. Since overburden stripping for the open pit was carried out under a separate contract, and in advance of the tailings facility construction, stockpiling of the selected material was required.

Selective overburden excavation was directed by the Consultant on a routine basis with the objective of eliminating silt lenses in the overburden, and maintaining a silt fraction of less than 5 percent in the sand stockpile. In practice, this required frequent sampling within the pit, and direction of the excavation by flagging of approved areas. Stockpiling of a total of 850,000 m<sup>3</sup> of material was required for use both in the tailings facility, and in other applications on the site. Control tests for gradation of material stockpiled were taken on a frequency of one test for every 4000 m<sup>3</sup>.

Under the contract for the tailings facility construction, the Contractor was required to excavate the filter material directly from the stockpile with no responsibility for material selection. The filter material was placed and spread in 250 mm lifts over the underseal, with material spread from an advancing layer of previously dumped material to prevent traffic of equipment on the underseal. Only nominal compaction of the filter material was required.

TABLE IV. Fill Material Density Test Results

Testing Period	No. of tests	Median field dry density (t/m <sup>3</sup> ) <sup>x</sup>	Mean % compaction (%) <sup>*</sup>	Standard deviation (%) (of % compaction)	Coeff. of variation
<u>1982</u>					
April	24	1.95	96.0+	3.6	3.7
May	57	1.95	92.0++	4.6	4.9
June	25	2.01	99.5	6.4	6.6
July	45	1.99	96.8	5.3	5.5
Aug	64	2.05	98.5	5.7	5.8
Sept	24	2.06	99.0	5.1	5.1
Oct	15	2.03	98.0	5.1	5.1
<u>1983</u>					
May	39	1.97	96.6+++	4.4	4.6
June	32	2.00	97.0	4.6	4.9
July	25	2.02	99.1	4.5	4.6

x Minus 20 mm fraction

\* All tests refer to ASTM D2049 and 8 compaction passes except as noted.

+ Results based on maximum density by ASTM D1557 and 5 compaction passes.

++ 33 tests at 5 compaction passes, 16 at 6 passes and 8 at 8 passes.

+++ 28 tests on maximum density by ASTM D1557 and field density by sand cone method.

Typical record test results for the gradation of the filter material placed in the facility are

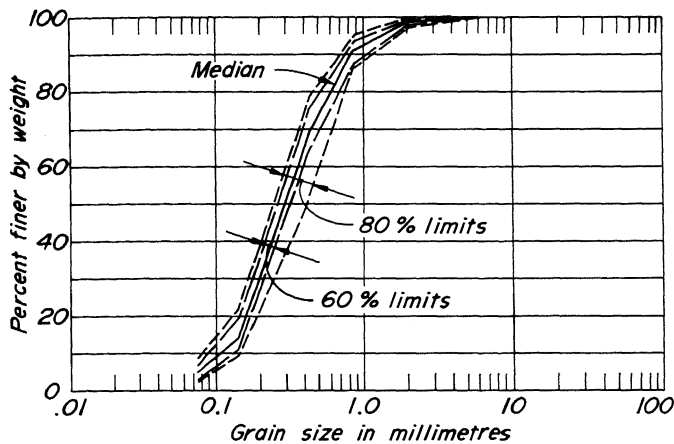

Fig. 5. Typical Record Tests Gradation Analyses for Filter Material (116 samples)

shown on Fig. 5. The median percentage passing the No. 200 sieve was slightly less than 5 percent, with the 60 and 80 percent upper limits exceeding the specified maximum by up to 4 percent. In practice this resulted in a small lowering of the coefficient of permeability with a measured median value of approximately  $6 \times 10^{-5}$  m/s.

#### INSTRUMENTATION

Instrumentation has been included in the tailings storage facility to monitor the various operational and environmental aspects of the design. The basic instrumentation allows for monitoring of the following components:

- (i) Tailings Flow Rates and Solids Content.
- (ii) Underdrainage and Supernatant Water Outflows.
- (iii) Pore Pressures within the Main Embankment.
- (iv) Regional Groundwater.

The tailings flow rate and solids content at discharge into the facility are continuously recorded by means of flow meters and density meters on the tailings pipelines. All water recovery from the facility is also continuously recorded by flow meters at the supernatant pumphouse, which allow for separate recording of underdrainage and supernatant flows. This information, together with meteorological data and an annual sampling program of tailings densities and moisture contents within the facility, will allow for annual water balance calculations to be made as an ongoing verification of the design.

Instrumentation within the main embankment for monitoring of pore pressures consists of pneumatic and standpipe piezometers on two instrumentation planes. The main embankment is designed as a free draining structure and it is extremely unlikely that it will be subjected to any significant hydraulic loading. The primary purpose of the instrumentation is to monitor the performance and efficiency of the various drainage systems. Since unsaturated conditions are

likely to frequently exist within the drainage systems, the pneumatic piezometers have been specially adapted to allow for periodic de-airing of the tips. Provision has also been made for the installation of similar tips within the tailings upstream of the embankment after an initial period of deposition.

Regional groundwater monitoring will be carried out by means of standpipe piezometers installed upstream and downstream of the facility with respect to the regional groundwater regime. Baseline hydrogeological data was collected during site investigations. Routine monitoring will include sampling and analysing for conductivity, and calcium and sulphate ion concentrations to indicate the presence of any seepage from the facility. Detailed monitoring on a less frequent basis will include analyses for specific heavy metals and radionuclides. Design studies have indicated that as a result of retardation by the underseal and underlying geological units, the impact of any potential seepage from the facility will be negligible.

#### INITIAL TAILINGS DEPOSITION

Mill start-up and initial tailings deposition at Key Lake commenced in September 1983. Normal start-up fluctuations resulted in some initial variations in tailings flow rates and solids content. However, by early November, 1983, some consistency in tailings feed rate and thickener operation had been achieved resulting in a uniform viscous tailings slurry with a solids content in the order of 38%.

The tailings solids are made up of 70% leach residues and 30% amorphous hydroxide precipitates and gypsum. A solids content of between 35% and 40% represents the maximum practical value that can be achieved using conventional thickeners for the leach residue, and a lamella thickener and drum filters for the precipitates. The design tailings slurry flow rate is between 50 and  $80 \text{ m}^3/\text{hr}$ .

Initial tailings deposition has achieved good laminar flow conditions from the spraybars with almost complete liquid solid separation taking place in the first 300 meters of beach.

Water recovery from the tailings facility has been entirely from the underdrainage system, and will continue to be so until the filter blanket is completely covered by tailings. Return water flow rates have been temporarily increased due to the recycling of contaminated water, stored in the tailings facility prior to start-up of the water treatment facilities. Recycling of the excess water is substantially complete at the time of writing.

Routine monitoring procedures have been implemented in accordance with the operating requirements. Monitoring has so far indicated that the tailings facility is performing as anticipated, albeit within a limited time period of readings.



## SUMMARY

The paper describes quality control and testing procedures used in the construction of the tailings facility for the Key Lake Project. Significant features of the design and results achieved are summarised as follows:

- (i) The underseal beneath the facility and intermediate seal in the main embankment were constructed by modification of the natural till material with bentonite. Using the specified procedures and a bentonite addition of approximately 3% by weight, a median coefficient of permeability of  $3 \times 10^{-10}$  m/s was achieved.
- (ii) Fill material for the facility consisted of till from the necessary excavations and an adjacent borrow pit. By using a method specification, quality control on fill placing resulted in median compaction results in excess of 95% of the maximum density as determined by ASTM D2049.
- (iii) Filter material for the filter blanket and the pervious upstream zone of the main embankment was selectively excavated during the open pit stripping operation. Selection procedures resulted in an average silt content in the filter material of approximately 5%.
- (iv) Tailings deposition into the facility commenced in September, 1983. The tailings are deposited in thin layers by the sub-aerial technique to achieve substantial liquid solid separation during deposition and to produce a drained laminated tailings deposit with a low coefficient of vertical permeability.
- (v) Instrumentation of the facility includes flow monitoring of the tailings input and water recovery from the supernatant and underdrainage recovery systems, pore pressure monitoring in the main embankment, and regional groundwater monitoring using standpipe piezometers. Most of the instrumentation is installed and present indications are that initial performance of the facility is in conformance with design objectives.

## REFERENCES

- Bouwer, H. (1966), "Rapid field measurement of air-entry value and hydraulic conductivity of soil as significant parameters in flow system analysis", *Water Resour. Res.* 2: 729-738.
- Bouwer, H. (1978), "Groundwater Hydrology", McGraw-Hill Book Company.
- Clarke, P.J., Jantzon, F.G.H., Neven, M., Weir, D.R., Masters, I.M., Berezowsky, R.M.G.S. and Day, M.D. (1980), "The Key Lake Uranium Process", 19th Annual Conference of Metallurgists of the CIM, Halifax, N.S., Canada, August.

Knight, R.B. and Haile, J.P. (1983), "Sub-aerial Tailings Deposition", 7th Panamerican Conference on Soil Mechanics and Foundation Engineering, Vancouver, B.C., Canada, June.

Topp, G.C. and Binns, M.R. (1976), "Field measurements of hydraulic conductivity with a modified air-entry permeameter", *Can. J. Soil. Sci.* 56: 139-147.