



Missouri University of Science and Technology
Scholars' Mine

International Conference on Case Histories in Geotechnical Engineering (2008) - Sixth International Conference on Case Histories in Geotechnical Engineering

14 Aug 2008, 4:30pm - 6:00pm

Calculation of Features of Many Row Pile Landslide Protection Structures

A. L. Gotman
Institute "BashNIIstroy", Ufa, Russia

M. A. Suvorov
Institute "BashNIIstroy", Ufa, Russia

Follow this and additional works at: <https://scholarsmine.mst.edu/icchge>



Part of the [Geotechnical Engineering Commons](#)

Recommended Citation

Gotman, A. L. and Suvorov, M. A., "Calculation of Features of Many Row Pile Landslide Protection Structures" (2008). *International Conference on Case Histories in Geotechnical Engineering*. 13. <https://scholarsmine.mst.edu/icchge/6icchge/session02/13>

This Article - Conference proceedings is brought to you for free and open access by Scholars' Mine. It has been accepted for inclusion in International Conference on Case Histories in Geotechnical Engineering by an authorized administrator of Scholars' Mine. This work is protected by U. S. Copyright Law. Unauthorized use including reproduction for redistribution requires the permission of the copyright holder. For more information, please contact scholarsmine@mst.edu.



CALCULATION OF FEATURES OF MANY ROW PILE LANDSLIDE PROTECTION STRUCTURES

A.L. Gotman

Institute "BashNIIstroy"
Konstituzii str., 3 Ufa, Russia, 450064

M.A. Suvorov

Institute "BashNIIstroy"
Konstituzii str., 3 Ufa, Russia, 450064

ABSTRACT

Results of investigation of pile many row landslide protection structures are shown. Experimental investigations of the behaviour of many row landslide protection structures are carried out on models in trays with the sandy soil under the action of the lateral landslide soil pressure. Based on results of the experimental investigations, the design scheme is improved and the method of calculation of many row pile landslide protection structures is worked out.

INTRODUCTION

In construction practice, more and more often there are cases when large soil masses on slopes or slopes with the given inclination angle need to be kept in stable condition when sport or cultural and entertaining structures as well as highways construction. Just the same problems are solved when constructing high retaining walls (10 m and more), deep trenches and tunnel portals enclosures, etc. Stability disturbance provokes the displacement of the large volumes of soil masses along the sliding surface at the significant depth, i.e. a deep shear takes place. One of the most effective methods of this problem solving is the engineering of landslide protection structures consisting of pile groups combined with the solid raft on slopes. Landslide pressure can reach great values and to provide stability of such soil masses many-row pile groups with the great number of piles are demanded.

In most cases pile structures are economically efficient and do not demand permanent maintenance and repair, they can be additionally used as buildings and structures foundations. Landslide protection pile structure (fig. 1) can be of different configuration in plan.

One row construction can be in kind of a continuous pile row (piles are situated close to each other) or with some distance between pile rows (fig. 1a). Such a construction is less efficient as piles are of pure bending behaviour. If in a continuous pile row the piles are moved apart to form 2, 3 or more rows (fig. 1 b,c), i.e. a many row structure is formed without pile number increase, the constructive scheme of a landslide protection structure can be essentially improved and many column strip frame in a soil is formed. In such a structure the lateral displacement, and the bending moments in piles are decreased (in comparison to the one row scheme) due to redistribution of forces in piles and a raft.

FEATURES OF A DESIGN SCHEME AND PROBLEMS OF THE EXPERIMENTAL INVESTIGATION

A scheme of behaviour of the linear landslide protection many row pile structure under the landslide soil pressure essentially differs from the traditional scheme with the loads (M, N and P) action through the column at the upper edge of the raft. Here the lateral load due to the sliding soil acts directly on pile shafts, and the vertical load and the bending moment are absent or insufficient. That's why the stressed-deformed state of the whole system will depend on the regularities of the landslide pressure distribution between the pile rows.

The soil pressure can be distributed to all pile rows (fig. 1b) or to several rows if the number of pile rows is large enough (fig. 1c). A design scheme should be constructed proceeding just from these regularities. The existing decisions use the simplified scheme which do not take a series of important factors into account thus decreasing the reliability of design results. Thus, in paper (Glotov, 1975) it is taken that all lateral load is transferred only to the first pile row from the side of the landslide pressure effect, i.e. the soil performance between piles is excluded. This contradicts the idea of soil mechanics about the soil behaviour as the compressible deformable medium. The passive soil pressure above the slid-

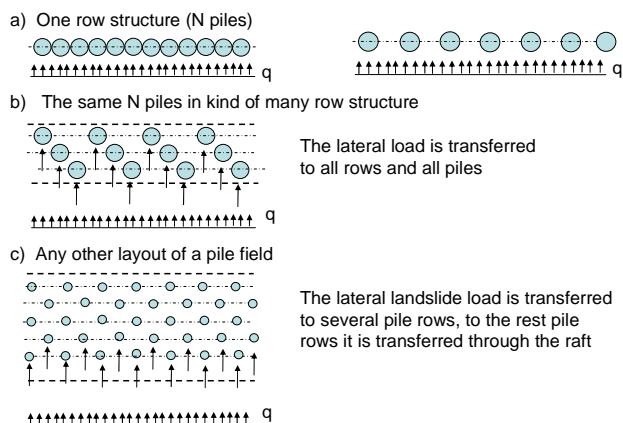

Fig. 1. Constructive scheme of landslide protection structures

ing surface is taken into account in a design scheme, although the necessity of this account is not quite clear.

That's why, to specify and improve the design scheme, it was decided to carry out the experimental investigations of the many row pile landslide protection structures on the models. The aim of these investigations is the evaluation of:

- the character of the landslide pressure distribution between pile rows;
- the optimum layout of the pile field;
- the necessity and extent of taking the passive soil pressure above the sliding surface into account.

EXPERIMENTAL INVESTIGATIONS

To obtain a qualitative pattern of a system pile-soil behaviour, as well as to compare the taken design scheme and a real behaviour in the landslide soil mass, a series of model tests of pile landslide protection structures under the landslide soil pressure was planned and carried out.

The tests were carried out in trays filled with the fine grained uniform sand. Pile models were hollow duralumin tubes of 28 mm diameter and 2.1 m length. One or two piles in a row were equipped with strain gauges with the sensitivity range $\sigma = 20\text{-}250$ MPa (fixed to the outside surface of the duralumin tubes by both sides), pile spacing $a = 200$ mm. Piles with strain gauges are shown in figure 2.

Piles with a free head were tested. The landslide pressure on the piles was initiated with a pressure of the laterally displacing soil in the upper movable tray. The lateral forces were applied to the movable tray with a jack into a thrust between the fixed and movable trays filled with the sand. Figure 3 shows the test scheme and the general view of the laboratory unit.

The lateral load was applied by steps. At each step of load data were recorded. As a criterion of the artificial deformations stabilization, the velocity of the lateral shear of the movable tray with sand was taken at each step of the lateral load application not exceeding 0.1 mm the last 15 minutes of watching the devices at the level of the load application.

The jack force was transferred mainly to the model piles and partially to the sand in the tray and the tray itself. To determine the exact model pile load value, the force provoking the displacement of the tray with the sand without the piles should be evaluated. The evaluation of the above force was carried out 4 times till the displacement reached 30 mm at the level of the load application. Then, after the processing of the initial data, diagrams of the dependence "load-displacement" were plotted and the displacement force was evaluated. The average displacement force for the tray with the compacted sand without piles was 245 ± 5 kg.

Tests were carried out with different number of pile rows, different pile spacing in a row and different pile row spacing. The following values were evaluated:

- dependence of the pile head displacement u_0 and the angle of its rotation ψ_0 at the level of soil surface upon landslide pressure;
- dependence of moments in the pile section upon the lateral load applied to the soil mass being displaced;

- regularity of distribution of landslide pressure between pile rows.



Fig.2 Appearance of piles equipped with strain gauges

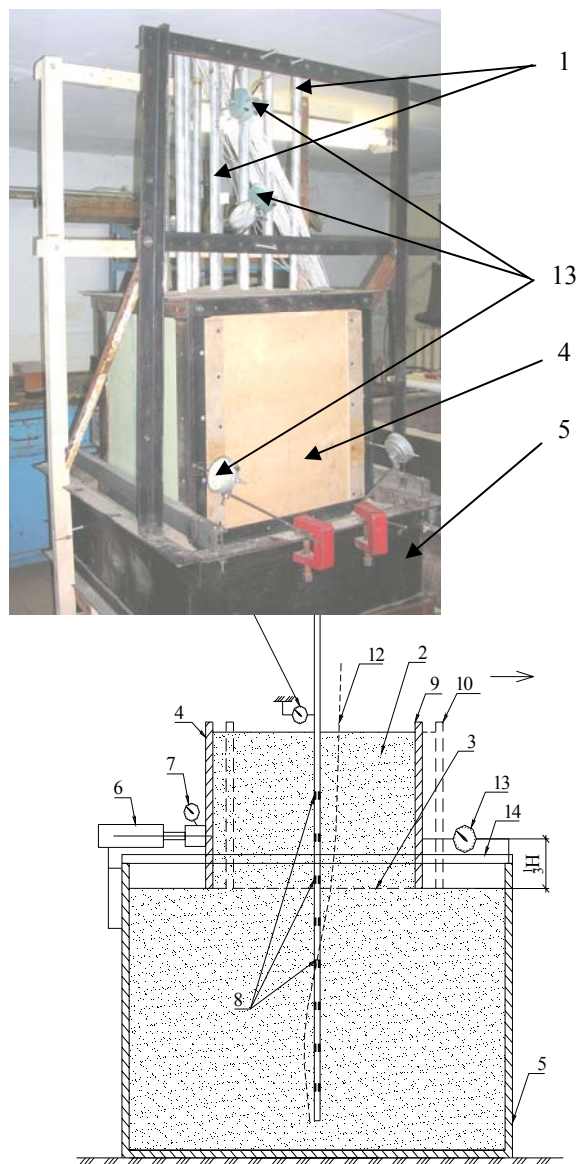

Fig.3. Scheme of three row construction and one row piling
1 - pile model; 2 - soil (uniform fine grained sand); 3 - artificial sliding surface; 4 - movable tray with sand; 5 - fixed tray with sand; 6 - jack; 7 - compression dynamometer; 8 - strain gauges; 9 - initial position of the movable tray; 10 - position of the movable tray after shear; 11 - direction of the shear; 12 - contour of pile model after shear; 13 - dial indicators; 14 - guides for the movable tray.

As a result, diagrams of dependence "load-displacement" and "load-rotation angle" were plotted. By strain gauges data, bending moment diagrams were plotted along the pile length for each step of loading. By results of model tests, dependences "landslide pressure-rotation angle" and "landslide pressure- lateral displacement" were plotted for each pile. It was obtained that the displacements of piles at the level of soil surface exceed that of movable tray, i.e. pile model was flexible and was bending in the process of loading. Figure 4 shows an example of one of diagrams for testing the two row pile structure with pile spacing and row spacing $3d$.

The tests showed the insufficient difference between the displacement of separate piles in the landslide protection structure, including that in different rows with many row pile arrangement.

To estimate the different pile structures, they were compared according to load data and the value of pile displacements. The comparison was carried out with the equal displacement of the movable tray of 30 mm.

By results of analysis of pile displacements, dependences of one pile load upon different configuration of pile arrangement are obtained. Figures 5-6 show the dependence of one pile load upon the pile row number and the dependence of one pile load upon the pile spacing in the row.

Table 1 shows relations of loads and displacements for different experimental schemes of pile structure.

Table 1. Comparison of loads and displacements

test No	Pile row spacing	Pile spacing in a row	Medium pile load	Pile displacement
One row structures				
1	-	$1d$	$(0,5\pm 0,1)\times P_1$	$(1,0\pm 0,1)\times U_1$
2	-	$2d$	P_1	U_1
3	-	$3d$	$(0,90\pm 0,1)\times P_1$	$(1,05\pm 0,1)\times U_1$
4	-	$4d$	$(0,94\pm 0,1)\times P_1$	$(1,07\pm 0,1)\times U_1$
Two row structures				
14	$2d$	$2d$	P_2	$U_2\pm 10\%$
15		$3d$	$(1,55\pm 0,15)\times P_2$	
16		$4d$	$(1,70\pm 0,15)\times P_2$	
5	$3d$	$2d$	P_3	$U_3\pm 10\%$
6		$3d$	$(1,20\pm 0,1)\times P_3$	
7		$4d$	$(1,80\pm 0,15)\times P_3$	
Three row structures				
11	$2d$	$2d$	P_4	U_4
12		$3d$	$(1,0\pm 0,1)\times P_4$	
13		$4d$	$(0,8\pm 0,1)\times P_4$	
8	$3d$	$2d$	P_5	displacements are non-uniform
9		$3d$	$(1,0\pm 0,1)\times P_5$	
10		$4d$	$(1,5\pm 0,25)\times P_5$	

Data of strain gauges for each test at each step of loading and unloading were recorded. By results of data processing, moment diagrams in piles at the different load were plotted. Figure 7 shows moment diagrams for one of piles for the test of two row pile structure with pile spacing $3d$ and row spacing $4d$.

The investigation of regularities of changes of bending moment values between pile rows showed that the maximum moment in a pile appeared in a row opposite to a point of load application.

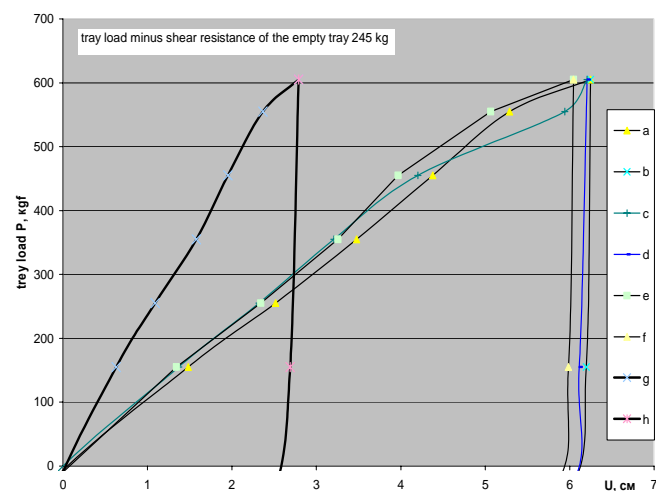

Fig. 4. Diagram of dependences "load-displacement" Two row structure (test No.7), 4 piles in the first row from the side of loading and 3 piles in the second row. a) pile 1 in the first row from the side of loading; b) pile 1 under unloading; c) pile 2 in the second row; d) pile 2 under unloading; e) pile 3 in the first row; f) pile 3 under unloading, g) tray displacement, h) tray displacement under unloading

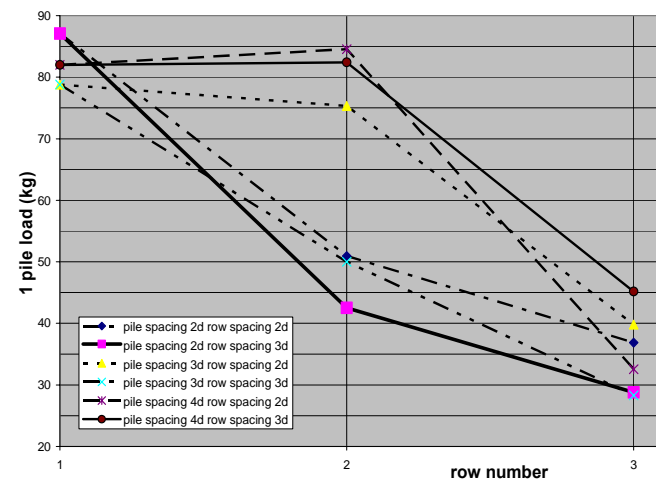

Fig.5. Dependence of one pile load on the number of pile rows

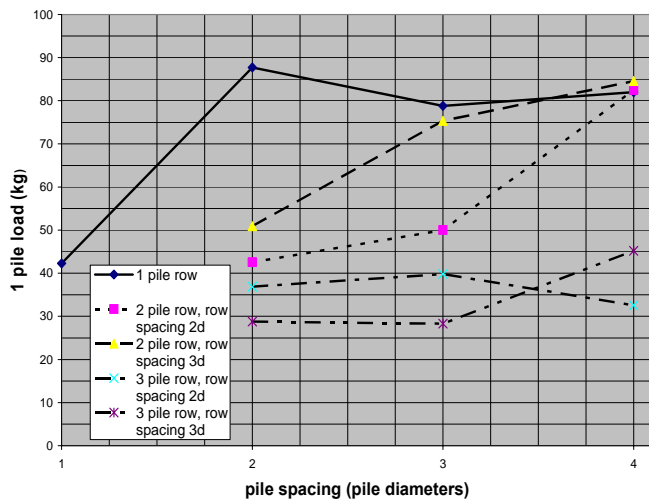

Fig. 6. Dependence of one pile load on pile spacing in a row

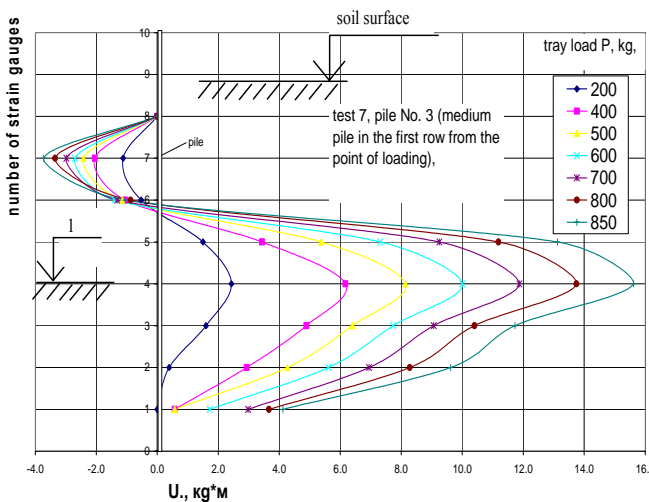

Fig. 7. Bending moment diagram with different tray loads
1- displacement line (bottom of movable tray); tray load minus displacement resistance of the empty tray 245 kg

ANALYSIS OF TEST RESULTS

The following conclusions can be done proceeding from the results of displacements evaluation given on diagrams:

Displacements of pile models in different rows in cohesionless soils even without combining them rafts are practically the same, especially in cases of close pile arrangement. The values of bending moments in piles of different rows differ not more than 10-13%.

When comparing landslide protection structures loads without a raft with the 30mm displacement of soil mass, the greatest value of displacement is shown in one row structures with pile spacing $2d$. The less value of displacement is with two row structures with pile spacing $4d$. The least effective are 3 row pile structures. With the continuous piling and equal soil displacement, one pile load is twice less than that of one row structure with pile spacing $2d$.

The best relation between pile load and displacement is when one row pile structure in cohesionless soil with the pile spacing $2d$.

The most single pile resistance for two row pile structure in cohesionless soil is noted to be with pile spacing in a row $4d$ (i.e. distance between the pile axis of the first and second row is $2d$).

Three row structures on the whole are less efficient; one pile load here is twice less than that in one- and two row structures.

The greatest efficient pile use for two row pile structure in cohesionless soil is with pile spacing in a row $4d$ (i.e. distance between the pile axis of the first and second row is $2d$).

The bending moments in pile rows differ not more than 10-13%.

On the whole, taking some soil homogeneity into consideration, the load distribution between rows can be taken uniform with the sufficient accuracy.

As figure 7 shows, partial restraint of a pile in a shear soil mass is observed in the upper part of a pile that proves the transfer of passive pressure of the shear soil mass to a pile even in case of a shear.

Thus, the model pile test showed the possibility and advisability of taking the soil resistance above the shear surface into account when calculation of a pile landslide protection structure under the lateral pressure.

The following should be noted. The model tests have been carried out with the lateral soil surface of the shear soil mass. This is practically never met on the landslide dangerous territories but it is possible with multilevel location of landslide protection structures.

For the case of the lateral surface of the shear soil mass and by results of the model pile structures test, it is shown that the passive soil pressure in sands is in the upper one third of the moving soil mass strata. The bottom two thirds of the soil mass height have an active shear pressure.

When considering the moment diagrams along the pile length it is evident that the lateral shear load is applied in kind of force distributed along the pile length.

Undoubtedly, data of model tests in sands can not be fully spread to all kinds of soils without the extra investigations.

For the inclined sites, it is necessary to take the decrease of the passive pressure into attention in the upper part of the slope for the inclined sites. The value of this decrease should become the point of the additional investigation.

DESIGN METHOD

According to results of experimental investigations, take the design scheme in general kind for the case when the lateral soil pressure is transmitted onto all pile rows. Such a scheme will take place in the cohesionless soils or in clay soils if

pile spacing in each row more than 4-5 d (where d - dimension of the pile cross-section) and a group is arranged with a chess pile location.

As the landslide protection structure is designed as a symmetrical one relative to a plane of the lateral load action, the design can be made from a flat scheme.

Write a system of equations of a raft equilibrium under the landslide pressure according to the symbols in figure 8.

$$M - \sum_{i=1}^m n_i (M_{ci} + N_{ci} y_i) = 0; \quad H - \sum_{i=1}^m n_i Q_{ci} = 0 \quad (1)$$

where n_i - number of piles in the i -th row;
 m - number of pile rows

$$M = \frac{1}{3} h_p \cdot E_a; \quad H = E_a \quad (2)$$

The rule of signs is evaluated from the condition that the moment, the horizontal load and the corresponding displacements u_o , the angle of piles rotation ψ_i as well as the abscissa of conjugate point y_i of the pile with the raft to the right of the rotation axis are positive.

Taking that the bending moment M_{ci} and the lateral force Q_{ci} in place of conjugation of the i -th pile with the raft are proportional to the horizontal displacement and the angle of the raft rotation in this point and considering the lateral force Q_q and the bending moment M_q due to the pile lateral soil pressure, obtain:

$$\begin{aligned} Q_{ci} &= -Q_{qi} + \rho_{2i} u_o - \rho_{3i} \psi_o \\ M_{ci} &= M_{qi} - \rho_{3i} u_o + \rho_{4i} \psi_o \end{aligned} \quad (3)$$

where ρ_{ki} - reaction of the k -th pile in i -th row with the unit displacements of its top;

U_o and ψ_o - the horizontal displacements and the angle of the raft rotation at the level of its base.

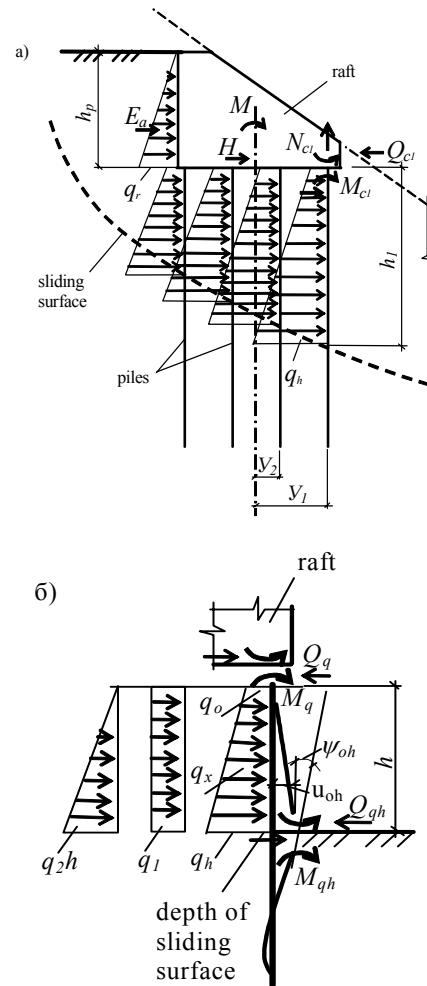

Fig.8. Design scheme of:
a) many row pile structure; b) a pile above the sliding surface of a soil mass

To evaluate the forces Q_{qi} and M_{qi} , the calculation scheme of the pile is presented (fig.8) as the rod bent due to the sliding soil pressure q_x , the upper end of the rod is rigidly restrained in the raft, the low end is elastically restrained at the level of the sliding surface of the slumping soil mass. The depth of the sliding surface h_i can be different for the different pile rows.

Taking into account that the raft base in the problem under solution is always lower than the soil surface, the pile pressure diagram will be of a trapezoidal form. Now, divide this diagram into two diagrams - uniformly distributed q , (dimensions t/m) and linearly increasing by depth with the abscissa in the level of the sliding surface q_2h (dimensions q_2 -t/m²).

According to design scheme in fig. 8, the boundary conditions are written.

At the depth of h from the raft base, the pile displacement u_{oh} and the rotation angle ψ_{oh} are evaluated by formulas

$$u_{oh} = M_{qh} \delta_{HM} + Q_{qh} \delta_{HH} \quad (4)$$

$$\psi_{oh} = M_{qh} \delta_{MM} + Q_{qh} \delta_{MH}$$

where δ_{HM} , δ_{MM} and $\delta_{MH} = \delta_{HM}$ are displacements and the rotation angle of a pile in the level of the sliding surface due to the bending moment $M_{qh} = 1$ and the lateral force $Q_{qh} = 1$.

Having written an equation of a beam bending with account of the boundary conditions (4) and conditions of pile head restraint into a raft, a system of four equations is obtained with M_q , Q_q , M_{qh} and Q_{qh} being unknown quantities.

$$\begin{cases} \frac{M_q h^2}{2} + \frac{Q_q h^3}{6} + \frac{q_1 h^4}{8} + \frac{q_2 h^5}{30} = EJ(M_{qh} \delta_{HM} + Q_{qh} \delta_{HH}) \\ -(M_q h + Q_q h^2 + \frac{q_1 h^3}{6} + \frac{q_2 h^4}{24}) = EJ(M_{qh} \delta_{MM} + Q_{qh} \delta_{MH}) \\ M_q + Q_q h + \frac{q_1 h^2}{2} + \frac{q_2 h^3}{6} = M_{qh} \\ Q_q + q_1 h + \frac{q_2 h^2}{2} = Q_{qh} \end{cases} \quad (5)$$

After solving the system of equations (5) obtain:

$$M_q = \frac{h}{A} (q_1 B + q_2 h C); Q_q = \frac{h}{A} (q_1 D + q_2 h F) \quad (6)$$

where:

$$\begin{aligned} A &= \frac{h^4}{12} + EJh \left(\frac{h^2}{3} \delta_{MM} + h \delta_{HM} + \delta_{HH} \right) + (EJ)^2 \delta_o \\ B &= \frac{h^5}{144} + \frac{1}{3} EJh^2 \left(\frac{5}{8} h \delta_{HM} + \frac{7}{8} h^2 \delta_{MM} + \delta_{HH} \right) + \frac{15}{16} (EJ)^2 h \delta_o \\ C &= \frac{h^5}{360} + \frac{1}{12} EJh^2 \left(\frac{7}{5} h \delta_{HM} + \frac{7}{30} h^2 \delta_{MM} + \frac{5}{2} \delta_{HH} \right) + \frac{1}{3} (EJ)^2 h \delta_o \\ D &= \frac{h^4}{24} + EJh (\delta_{HH} + \frac{5}{24} h^2 \delta_{MM} + (EJ)^2 \delta_o) \\ F &= \frac{h^4}{80} + \frac{1}{2} EJh \left(\frac{3}{4} h \delta_{HM} + \frac{3}{20} h^2 \delta_{MM} + \delta_{HH} \right) + \frac{1}{2} (EJ)^2 \delta_o \\ \delta_o &= \delta_{HM} \delta_{MM} - \delta_{MH}^2 \end{aligned} \quad (7)$$

EJ - flexural rigidity of the pile lateral section.

Substituting (3) and (6) into (1), obtain the expressions for the evaluation of the displacement u_o and the rotation angle ψ_o due to soil pressure q :

$$u_o = \frac{M_r A_1 - H_r A_2}{\eta}; \quad \psi_o = \frac{M_r B_1 - H_r B_2}{\eta} \quad (9)$$

where:

$$M_r = \frac{1}{3} h_p E_a + \sum_{i=1}^m M_{qi} n_i; H_r = E_a + \sum_{i=1}^m Q_{qi} n_i \quad (10)$$

$$A_1 = \sum_{i=1}^m n_i \rho_{3i}; A_2 = -\sum_{i=1}^m n_i (\rho_{4i} + y_i^2 \rho_{1i}) \quad (11)$$

$$B_1 = -\sum_{i=1}^m n_i \rho_{2i}; B_2 = \sum_{i=1}^m n_i \rho_{3i}$$

$$\eta = B_2 A_1 - B_1 A_2$$

Substituting u_o and ψ_o from formulas (9) into (3), the forces Q_{oi} and M_{oi} can be evaluated while pile restraint into the raft. Then the forces M_z and Q_z under Q_{oi} and M_{oi} action and under the sliding soil pressure are calculated for each separate pile by the known method.

The values of pile reactions at the level of their restraint into the raft ρ_1 , ρ_2 , ρ_3 and ρ_4 are evaluated in piles unit displacements at the level of the sliding surface by formulas:

$$\rho_1 = \frac{F}{7 \cdot 10^{-3}}; \rho_2 = \frac{\delta_1}{\rho_o}; \rho_3 = \frac{\delta_2}{\rho_o}; \rho_4 = \frac{\delta_3}{\rho_o} \quad (12)$$

where δ_1 , δ_2 and δ_3 are the lateral displacements and the angle of a pile rotation with the free upper end at the level of the raft base due to $M_{qh} = 1$ and $Q_{qh} = 1$ applied at the same level;

F - a vertical load limit pile base resistance. Values δ_1 , δ_2 , δ_3 and ρ_o are evaluated by formulas:

$$\delta_1 = \frac{h}{EJ} + \delta_{MM}; \delta_2 = \frac{h^2}{2EJ} + \delta_{MM} h + \delta_{MH} \quad (13)$$

$$\delta_3 = \frac{h^3}{3EJ} + \delta_{MM} h^2 + 2\delta_{MH} h + \delta_{HH}; \rho_o = \delta_3 \delta_1 - \delta_2^2 \quad (14)$$

The values of the unit displacements δ_{HH} , δ_{MM} , and $\delta_{MH} = \delta_{HM}$ are evaluated by means of lateral load calculation of the low pile part embedded into soil in a linear deformable medium. Just the specificity of pile behaviour in landslide protection structures under "deep" shear should be taken into account. In such structures large diameter and large length bored piles are used in order pile shaft below the sliding surface resists the lateral load due to the sliding soil mass. Here the pile shaft works at a larger depth and hence, the possible heterogeneity of the base by its length should be taken into account in the design scheme, i.e. it is advisable to consider the multilayer base with the constant subgrade ratio within each layer.

Such a design scheme was realized with the finite element method in paper (Gotman, 2000) and used in given method of calculation.

According to given design method, the computer program is

worked out, which allows to evaluate the lateral displacement and the rotation angle of the raft, bending moment and the lateral force in piles of each row including in place of a pile restraint into a raft and along the pile shaft.

CONCLUSIONS

1. Different constructive schemes of many row landslide protection structures for slopes are considered and necessity of development of the effective method of their calculation under the lateral landslide soil pressure with the deep shear is validated.
2. Based on results of the experimental investigations on models, some regularities of pile many row landslide protection structures under the influence of landslide soil pressure are developed, including:
 - with three and two row pile arrangement, the lateral sliding soil pressure distributed between rows is roughly uniform;
 - the optimum values of pile spacing in a row and distance between rows are diagnosed.
 - when pile landslide protection structures calculation, it is advisable to take passive pressure of the moving soil mass onto the pile into attention. Calculation of piles above the line of shear as cantilever leads evidently to a significant rise in price of landslide protection structure.
3. A design scheme of the pile many row landslide protection structure is improved, in which all landslide pressure is transferred directly to the piles shafts and distributed among all rows uniformly. Design method is worked out and recommended for the practical use by specialists-designers of the landslide protection structures.

REFERENCES

Glotov, N.M., Luga, A.A., Silin, K.E. and Zavriev, K.S. [1975]. "Pile foundations", *Publishes Transport*, Moscow, p.432.

Gotman, A.L. [2000]. "Calculation of the influence of the mutual action of vertical and lateral loads on the variable section piles with finite element method, "*Bases, foundations and soil mechanics* ", Moscow, No.1, pp.6-12.