



Missouri University of Science and Technology
Scholars' Mine

International Conference on Case Histories in Geotechnical Engineering (1993) - Third International Conference on Case Histories in Geotechnical Engineering

03 Jun 1993, 10:30 am - 12:30 pm

Investigation of Collapse of an Apartment Building Due to Differential Filling

N. N. Som
Jadavpur University, Calcutta, India

R. B. Sahu
Jadavpur University, Calcutta, India

Follow this and additional works at: <https://scholarsmine.mst.edu/icchge>

 Part of the [Geotechnical Engineering Commons](#)

Recommended Citation

Som, N. N. and Sahu, R. B., "Investigation of Collapse of an Apartment Building Due to Differential Filling" (1993). *International Conference on Case Histories in Geotechnical Engineering*. 8.
<https://scholarsmine.mst.edu/icchge/3icchge/3icchge-session08/8>

This Article - Conference proceedings is brought to you for free and open access by Scholars' Mine. It has been accepted for inclusion in International Conference on Case Histories in Geotechnical Engineering by an authorized administrator of Scholars' Mine. This work is protected by U. S. Copyright Law. Unauthorized use including reproduction for redistribution requires the permission of the copyright holder. For more information, please contact scholarsmine@mst.edu.



Investigation of Collapse of an Apartment Building Due to Differential Filling

N. N. Som

Professor of Civil Engineering, Jadavpur University, Calcutta, India

R. B. Sahu

Lecturer in Civil Engineering, Jadavpur University, Calcutta, India

SYNOPSIS Investigation of collapse of a five storey residential building in Calcutta is described. The failure occurred soon after construction but, fortunately, before occupation. Detailed soil investigation revealed that a bowl-shaped depression, 5.5 m deep, existed in the collapsed building area which was subsequently filled up. The foundation raft was placed 5.325 m below ground level and the subsequent filling put an overburden pressure of varying magnitude resulting in non-uniform pressure on the subsoil. This was apparently not considered in design. Factor of safety was found to be low against bearing capacity failure and the building tilted towards the heavier load concentration. This caused over-stressing, in structural elements which gradually failed and ultimately led to the collapse of the building.

INTRODUCTION

A six-storey apartment building collapsed soon after construction near Calcutta in June 1990. The building was one of a group of 13 buildings being built for a residential complex. It was in its finishing stages and was soon to be occupied. Fortunately, no loss of life occurred. A detailed failure investigation was carried out to ascertain the cause of collapse of the building - particularly with a view to determining if the remaining buildings at the site would be safe for occupation.

LAYOUT OF BUILDINGS

Fig. 1 shows the layout plan of the building complex at 5/7 Buroshibtala Main Road in south-west Calcutta. In all, there were thirteen buildings in various stages of construction, Table I.

TABLE I. Buildings at 5/7 Buroshibtala Main Road

Building No.	Condition of the Building
1	Reported complete.
2, 3, 6, 10, 11, 12, 13	Under construction.
4	Building collapsed.
5	Building partially collapsed and subsequently demolished.
	Construction yet to be started.
9	Only foundation work done.

NATURE OF COLLAPSE

The collapsed building, No. 4, formed part of a group of three buildings which were built almost touching one another near the eastern part of the

site. The building had collapsed towards the north-west corner - one late evening. Although the adjacent building 3 was found to remain unaffected the northern part of building 5 was severely damaged during the collapse.

A visit to the site after the collapse revealed that the building had tilted heavily towards the N-W corner prior to collapse and had dragged along with it a part of building 5 which had to be demolished later.

METHOD OF INVESTIGATION

An investigation of failure was commenced soon after the collapse of the building with the following terms of reference :

- Detailed soil exploration would be done to determine the subsoil profile at the site and its variation at building locations and to ascertain the engineering properties of different strata.
- Excavation would be done to expose the foundation of the collapsed building to determine the type of foundations provided for the building.
- Foundation analysis would be done to investigate the status of foundations and to determine if the collapse was due to any deficiency in the foundation.

SOIL INVESTIGATION

Soil exploration was done with 12 nos. 15-25 m deep boreholes, 14 nos. 10 m deep dynamic cone penetration tests, in-situ standard penetration tests within boreholes and laboratory tests on disturbed/undisturbed samples collected from the boreholes.

The boreholes were done at locations indicated in Fig. 1 to determine the subsoil stratification at the building site and to collect disturbed/undisturbed samples for testing. The borehole locations were so chosen as to get sufficient

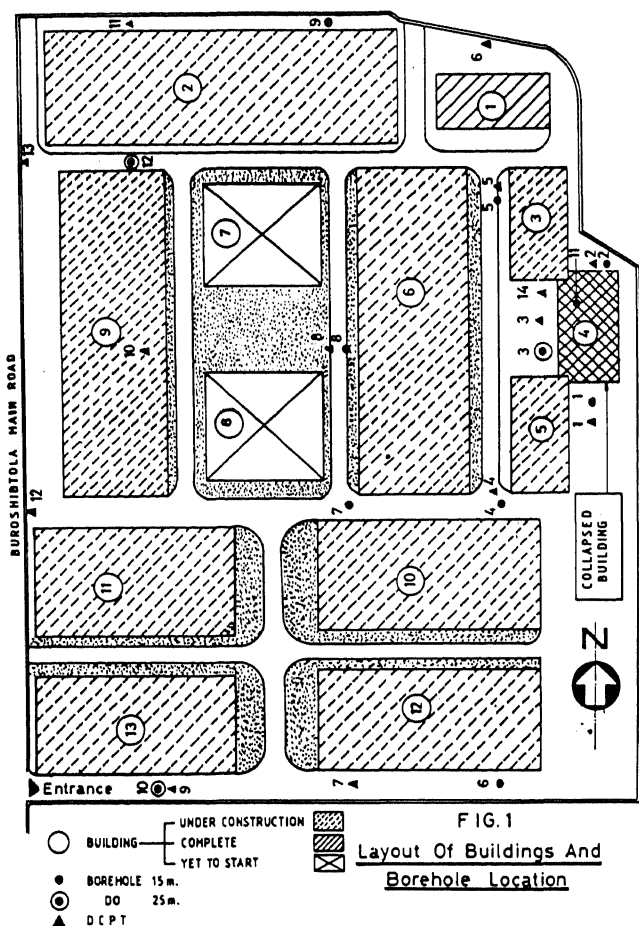

TABLE II. Depth of Fill at Borehole Locations

Borehole No.	Depth of Fill (m)
1	2.0
2	1.5
3	5.5
4	4.0
5	1.7
11	4.0

- which occupies most of the area immediately beneath the top soil is found to exist in the collapsed building area with a well-defined bowl-shaped profile.

It was apparent that a bowl-shaped depression existed in the vicinity of the collapsed building which was later filled up. The major component of the fill was a light-weight dark grey granular material with very soft consistency. It was not a geological material in the sense that it did not come from a naturally occurring soil. From visual observation and from elementary tests like, burning the material appeared to a factory waste, predominantly rice husk.

The depth of fill at different locations could be obtained from the borehole and the SPT data. Further information could be obtained from the DCPT results which, when correlated with the borehole observations give indications of the depth of fill at locations where no boreholes were done. Table III gives the depth-wise variation of DCPT data at 14 locations. The N_c values are particularly low (less than 2) down to some depth in locations 1, 2, 3, 4, 5 and 14 while the values are considerably higher in other locations.

TABLE III. Summary of DCPT Data: N_c (blows/30 cm)

Depth (m)	Test Location													
	1	2	3	4	5	6	7	8	9	10	11	12	13	14
1.5	3	2	2	3	2	3	3	4	12	3	3	3	3	6
3.0	2	4	1	2	2	6	7	8	3	4	4	6	5	1
6.0	7	8	1.5	4	6	10	8	9	5	6	7	10	7	3
8.0	8	7	3	11	8	20	9	15	14	7	7	14	9	9
10.0	9	20	10	15	15	20	10	20	15	10	10	15	15	18

A comparative study of the borehole data as well as the SPT and DCPT values clearly show the presence of filled up soil in the area surrounding the collapsed building. The rest of the area did not give evidence of any filled up soil. There, of course, was a top soil at all borehole and DCPT locations of thickness varying from 0.5-1.5 m.

An attempt has been made to draw an approximate contour plan of the bottom of the fill in the collapsed building area - based on the field observations. The plan, thus obtained, is shown in Fig. 4. Although some interpolation had to be made to draw the contour plan it gives a fair representation of the depth of fill at different locations. It is apparent that the fill extended over most of the area covered by the three buildings in the collapsed zone. The maximum depth of fill, 5.5 m, was, however, found just west of the collapsed building. The depth of fill varied from 5 m to 2 m from west to east under the collapsed building.

data for analysis of collapsed building and to determine the status of foundation of the others.

The dynamic cone tests were done to ascertain the variation of soil strata within the top 10 m particularly in the vicinity of the collapsed building. These data along with the borehole observations, would give the nature and extent of filling, if any, near the different building blocks.

The soil profiles as revealed by the boreholes are shown in Figs. 2 and 3. Fig. 2 gives the soil profile in the area surrounding the collapsed building, while Fig. 3 gives the soil profile in the rest of the area. There appears to be some distinct difference in the soil profile in the vicinity of the collapsed building and in the rest of the area.

The subsoil in the collapsed building area, consisted of a heterogenous fill of brickbats, rubbish, fine sand and a black/dark grey peat-like substance with high organic content. This was followed by successive layers of silty clay/clayey silt overlying medium to dense sand approx. 12 m below ground surface. The depth of fill at various locations near the collapsed building is shown in Table II. The fill was maximum near Borehole 3 (5.5 m) and gradually decreased on all sides.

The soil stratification in the rest of the area was fairly uniform with some variation in the thickness of individual stratum.

A comparative study of the soil profiles in the collapsed building area and the rest of the site showed remarkable similarity of soil stratification below 6 m depth. Even the soil of Stratum II

Fig. 5 shows the soil properties in the collapsed building area as obtained from laboratory tests.

The ground water table, on average, was 2 m below G.L.

FOUNDATION ANALYSIS

All the buildings at 5/7 Buroshibtala Main Road had similar structural arrangement with R.C.C. frames supported on two-way interconnected strip foundations. However, the subsoil condition in the collapsed building area being different from the rest of the area separate foundation analysis was done for the collapsed building.

The plan of the collapsed building is shown in Fig. 6. The building covered an area of 8 m x 18.5 m having symmetry about the staircase block. There

were 12 columns in the building frame. The foundation details were obtained from excavation done at the site after the collapse, Fig. 7. The columns were supported on 1.2 m wide R.C.C. strips running east-west with interconnection in the N-S axis. The columns on either side of the staircase block were placed on a 6 m x 4 m grid (approx.) with a 2 m wide cantilever in the northern and southern faces. The vertical loads on the columns of the building frame as calculated from structural details are shown in Table IV.

It will be evident from the foundation details shown in Fig. 7, that - although the columns of the building frame were supported on two-way interconnected strips - the foundation as a whole would behave almost as a raft foundation placed 5.325 m below existing G.L. The equivalent raft covered a plan area of 9.2 m x 15.7 m with four

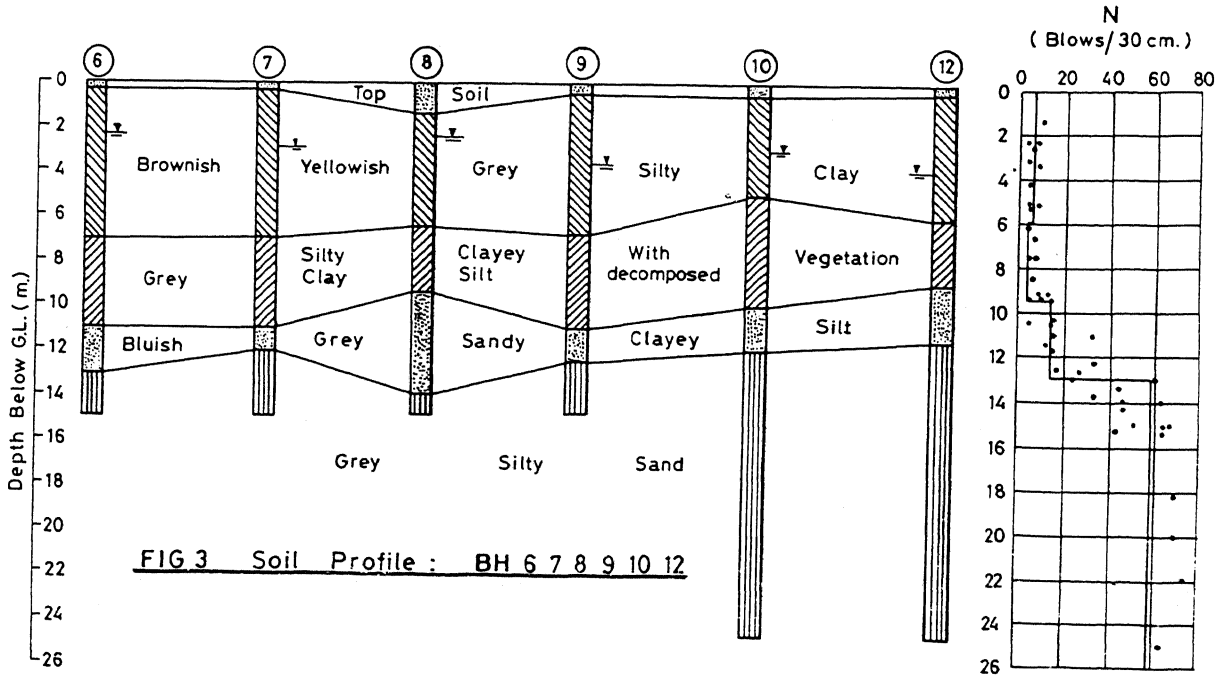
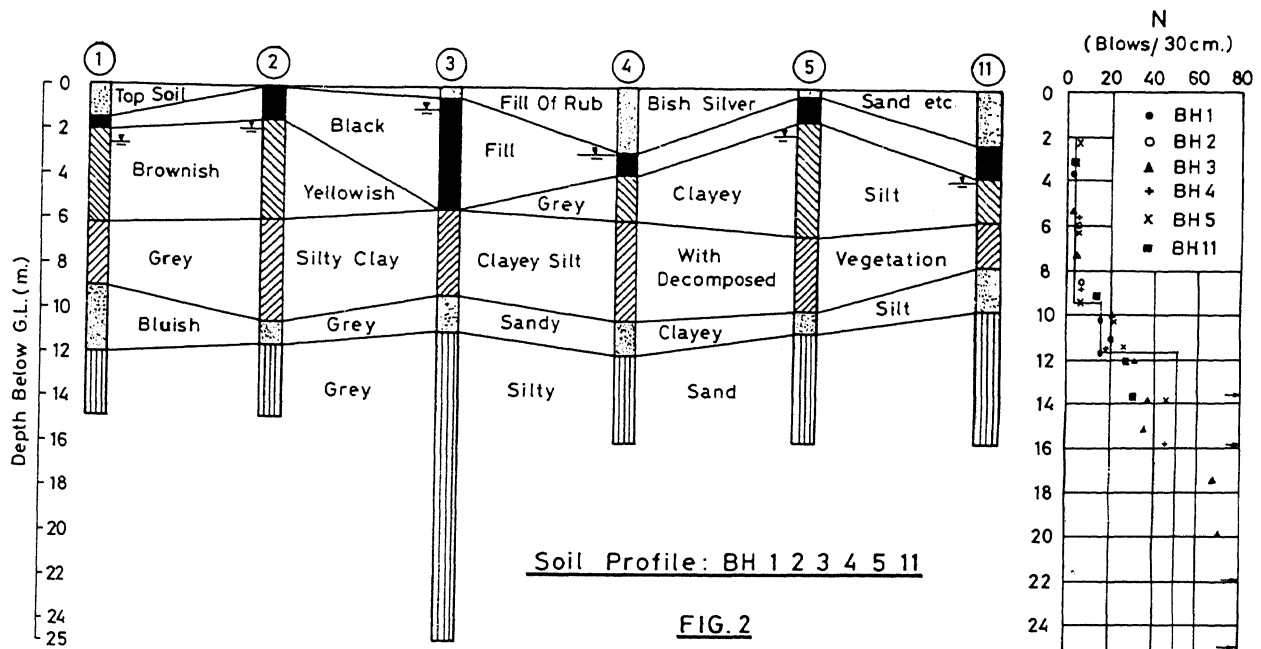

TABLE IV. Loading data

Col. Mkd.	D.L.	60% L.L.	Design Load
C ₁	97.1	9.5	106.5
C ₂	66.2	10.7	77.0
B ₁	153.5	15.4	168.9
B ₂	119.5	15.6	135.1
A ₁	75.0	9.2	84.2
A ₂	84.4	5.9	90.3

rectangular openings of 4.8 m x 2.8 m each. The openings covered only 37% of the area of the raft. The pressure in the subsoil from the strip footings would overlap within a shallow depth below the footings thereby giving the effect of a raft foundation so far as the stresses in the subsoil were concerned. It was further observed from the foundation details that the underside of the raft was placed 5.325 m below existing ground level. The area under the collapsed building - as already pointed out - had a bowl-shaped depression which was subsequently filled up. From the contour plan of the bottom of the fill, Fig. 4, it is possible to draw the original ground profile in the E-W direction under the collapsed

building area, Fig. 8. It would appear that the depth of the fill varied from 5 m on the western face to 2 m on the eastern face. The foundation raft was placed at 0.325 m below original G.L. at the western face of the building and excavation of varying depth - upto a maximum of 2 m at the eastern side - was made to build the foundation. The area was subsequently filled up with the factory waste to arrive at the finished ground level. With regard to the net foundation loading, therefore, a fill of varying depth - 5 m on the western side to 2 m on the eastern side - is to be considered on the foundation raft. This would give additional foundation pressure of 7.5 t/m² to 3 t/m² due to the overburden. The backfill upto the original ground profile was actually a replacement of the excavated soil and need not be considered as an additional load on the subsoil. The net foundation pressure below the raft may thus be obtained by considering the superstructure load and the backfill load separately. The data are shown diagrammatically in Fig. 8.

Bearing Capacity and Settlement Analysis

The influence zone beneath a 15.7 m x 9.2 m raft foundation - for bearing capacity analysis - would extend to about 7 m below the underside of the raft, i.e. 12.3 below present G.L. This would involve essentially the soil of Strata III and IV. The ultimate bearing capacity of the foundation may be worked out at 18.6 t/m² from the properties of Stratum III (C_u = 3 t/m²) which is the dominant stratum within the influence zone. The factor of safety on the average foundation pressure may then be obtained as shown in Table V.

TABLE V. Factor of Safety

Loading condition	q _{ult} (n) (t/m ²)	q _{net} (t/m ²)	F.S.
D.L. only (incl. backfill)	18.6	13.5	1.40
DL + LL (incl. backfill)	18.6	14.4	1.30

The calculated factors of safety are well below the minimum value 2.5 normally adopted for building foundations. Even considering that the live load in the building was yet to be applied the factor of safety with respect to dead load only was no greater than 1.4.

It is to be appreciated here that a factor of safety of 1.4, although not acceptable, should not automatically mean collapse of the foundation. However, considerable yielding of the soil would have taken place beneath the edge of the foundation resulting in significant plastic deformation of the soil. This would lead to tilting of the building towards the heavier stress concentration. It is likely, therefore, that the building soon after construction began to tilt towards the heavily loaded western side consequent upon the low factor of safety against bearing capacity failure.

The total settlement of foundations on clay designed with adequate factor of safety against bearing capacity failure is given by the sum of the immediate (elastic) settlement and long term

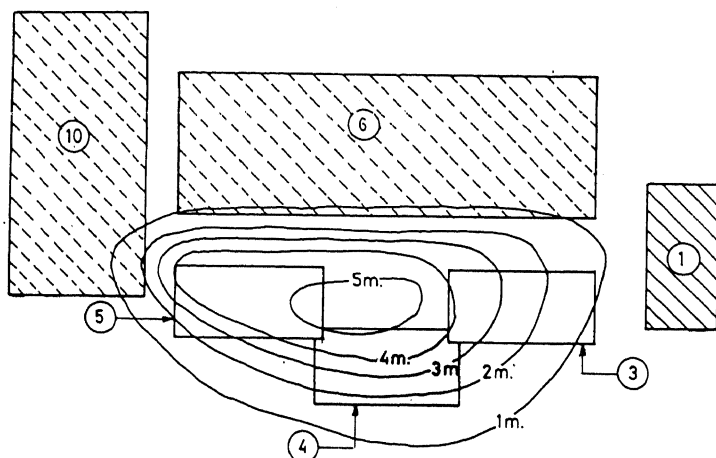

FIG.4 Contour Plan Of Bottom Of Filled Up Soil

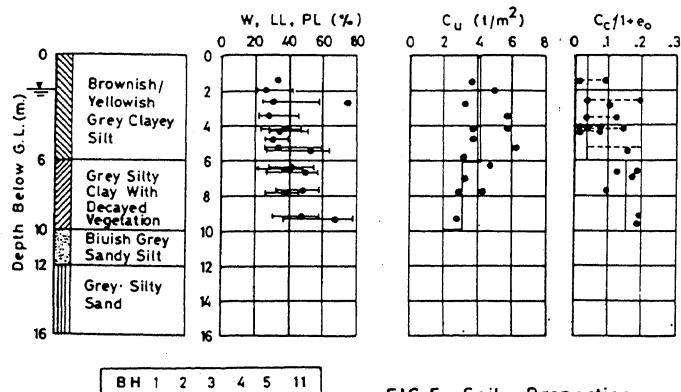

FIG.5 Soil Properties

consolidation settlement.

The immediate settlement of the foundation of the collapsed building would consist of the elastic deformation of Stratum III and the settlement of the sandy soil of Strata IV and V enclosed within the influence zone.

The immediate (elastic) settlement of the foundation due to the cohesive soil of Stratum III has been obtained by Boussinesq analysis. Calculations have been made separately for the uniformly distributed load of 11.3 t/m² and a triangular loading. The settlement, thus calculated, has been added to the deformation caused by the sandy soil of Strata III and IV, to get the immediate settlement of the foundation as 43 mm in the eastern face and 37 mm in the western face.

The long-term consolidation settlement of the foundation is given by the compression of all relevant strata enclosed within the influence zone,

i.e. 0.7 m of Stratum II and 4 m of Stratum III - the compression of the sandy soil of Strata IV and V being already included in the immediate settlement. Calculations were made separately for the eastern and western faces of the foundation to account for the variable loading and subsoil condition. The final consolidation settlement of the western and eastern faces of the building worked out as 416 mm and 240 mm respectively.

The estimated total settlement of two sides of the building is summarised in Table VI.

TABLE VI. Total Settlement

Side	Settlement (mm)			Diff. δ	Angular distortion
	Imme- diate P_i	Consoli- dation P_c	Total ($P_i + P_c$)		
West	41	416	457	180	$\frac{1}{51}$
East	37	240	277		

It may be seen that the estimated final settlement as well as the final angular distortion of the building would go far beyond the permissible limits for a conventional framed structure. Therefore, the foundation as provided for the collapsed building was inadequate to support the combined loading of the building and the filled-up soil. The effect of the latter was, perhaps, not considered at all.

Status of Settlement at the Time of Collapse

The estimated settlement of the foundation, as given in Table VI, would occur as a long term phenomenon after full consolidation of the soil under the applied load is over. In the present case, however, the building collapsed shortly after construction when the full consolidation settlement was yet to occur. The building took one year for construction and six months after construction it collapsed. This would give an approximate period of one year during which the dead load of the building had been acting on the foundation. An analysis of the rate of settlement shows that nearly 60% of the consolidation settlement may have occurred during this period. The estimated settlement of the building at the time of collapse is shown in Table VII.

TABLE VII. Settlement of Foundation at the Time of Collapse

Side	Settlement (mm)			Angular distortion (E-W)
	Imme- diate	Consoli- dation	Total	
West	41	240	281	$\frac{1}{86}$
East	37	138	175	

An examination of the settlement data summarised in Table VII shows that the building had already undergone considerable differential settlement and the angular distortion was as high as 1/86 at the time of collapse. This is far in excess of the permissible angular distortion for conventional framed buildings where no specific design is made to take account of excessive angular

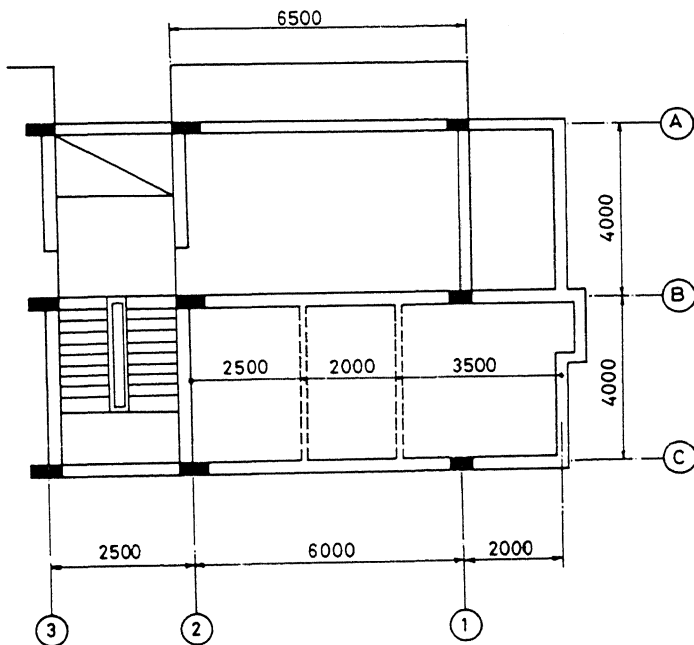

FIG. 6 Structural Plan: Building 4

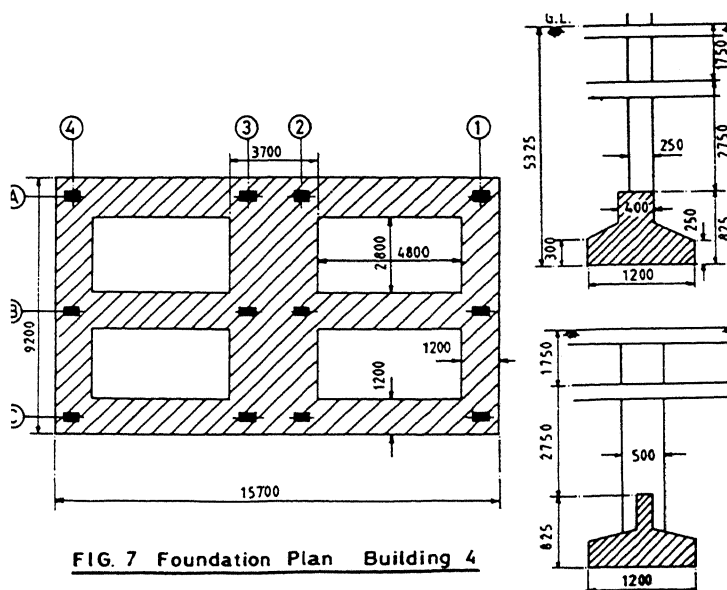

FIG. 7 Foundation Plan Building 4

distortion. Further, the angular distortion would be higher than that indicated in Table VII because of the yielding of the soil under low factor of safety against bearing capacity failure. The structural calculations had shown that the beams and columns of the building frame were not adequately designed even for dead load and live load only. The structural members, would, therefore, have no capacity to withstand the additional stresses due to angular distortion. They would have failed under the excessive differential settlement leading finally to the collapse of the building.

CAUSE OF COLLAPSE

The R.C.C. framed building had collapsed soon after construction. The investigation clearly suggested the following cause of collapse of the building :

a. The columns of the building frame were supported on 1.2 m wide R.C.C. strip footings but the dimensions of the strip and two-way interconnection provided at site indicate that the entire foundation behaved more or less as a raft foundation of size 9.2 m x 15.7 m.

b. The soil in the collapsed building area had a bowl-shaped depression with a maximum depth of 5.5 m just west of the building. Differential

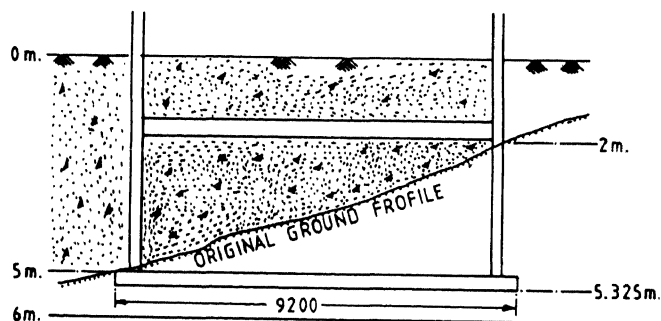

GREY SILTY CLAY WITH DECAYED WOOD

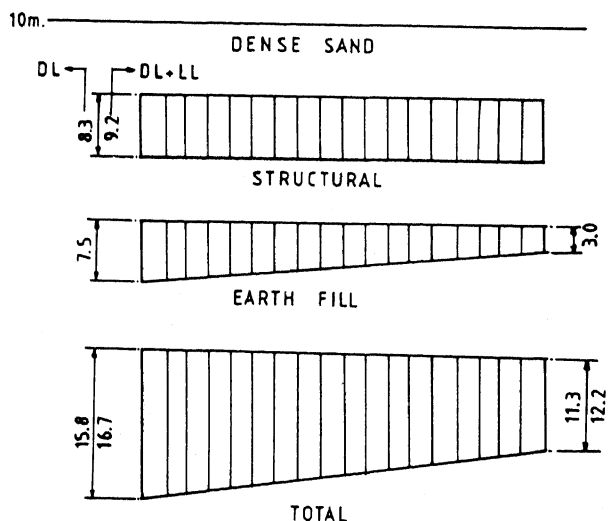

FIG. 8 Foundation Pressure Building 4 (t/m^2)

excavation was made across the building (E-W) from the then existing ground profile to locate the foundation at a depth of 5.325 m and the area was subsequently filled up. This resulted in differential filling on the foundation raft giving a non-uniform pressure of 16 t/m^2 on the western side and 11 t/m^2 on the eastern side of the foundation. The effect of differential filling was, perhaps, not taken into consideration in the foundation design.

c. The foundation as provided at site did not have adequate factor of safety against bearing capacity failure. Even for D.L. only, the factor of safety was as low as 1.4. This would lead to excessive yielding of the subsoil and the building must have tilted towards the western face due to heavier stress concentration.

d. Although the consolidation settlement of the foundation did not occur fully at the time of collapse, analysis of rate of settlement suggests that nearly 60% of the consolidation settlement would have occurred in one year after construction. Further, the settlement would be appreciably more in the western side because of non-uniformity of subsoil condition and differential load distribution. All these resulted in an estimated settlement of 281 mm on the western side and 175 mm on the eastern side. These settlements are very high and they led to an estimated angular distortion as high as 1/86 towards the western side of the building.

e. The above would affect the stability of the building and introduce excessive secondary stresses in the building frame. The structural elements did not have the capacity to withstand these stresses. They gradually failed and led to the ultimate collapse of the building.

f. Other buildings in the area did not have the same situation. There was no major filling in these areas and the foundations provided appeared adequate.

CONCLUSION

The collapse of a five-storey residential building soon after construction occurred due to non-uniform foundation pressure caused by differential filling on the foundation raft. Factor of safety against bearing capacity failure was low. This led to appreciable yielding of the subsoil towards the region of heavier stress concentration. Consequent over-stressing of the structural elements led to their gradual failure and ultimate collapse of the building.

ACKNOWLEDGEMENT

The investigation was carried out on behalf of an Enquiry Committee set up by the Government of West Bengal, India.