



Missouri University of Science and Technology
Scholars' Mine

International Conference on Case Histories in
Geotechnical Engineering

(2004) - Fifth International Conference on Case
Histories in Geotechnical Engineering

13 Apr 2004 - 17 Apr 2004

Success and Failure in Predicting Pile Performance

Harry G. Poulos

Coffey Geosciences Pty Ltd. / University of Sydney, Australia

Follow this and additional works at: <https://scholarsmine.mst.edu/icchge>

 Part of the [Geotechnical Engineering Commons](#)

Recommended Citation

Poulos, Harry G., "Success and Failure in Predicting Pile Performance" (2004). *International Conference on Case Histories in Geotechnical Engineering*. 4.

<https://scholarsmine.mst.edu/icchge/5icchge/session00f/4>

This Article - Conference proceedings is brought to you for free and open access by Scholars' Mine. It has been accepted for inclusion in International Conference on Case Histories in Geotechnical Engineering by an authorized administrator of Scholars' Mine. This work is protected by U. S. Copyright Law. Unauthorized use including reproduction for redistribution requires the permission of the copyright holder. For more information, please contact scholarsmine@mst.edu.



SUCCESS AND FAILURE IN PREDICTING PILE PERFORMANCE

Harry G. Poulos

Coffey Geosciences Pty Ltd. Sydney, &
University of Sydney, Australia

ABSTRACT

This paper reviews the anatomy of predictions for pile and pile group performance, and discusses the various facets of the prediction process. A series of case histories is presented in which successful predictions were made of the pile performance. Most of these cases involve a single pile or a small group of piles. A further series of case histories is then discussed in which the predictions were far less successful. Most of these cases involve larger pile groups. The reasons for the success or otherwise of the predictions are discussed, and it is concluded that successful predictions require a combination of good ground characterization, a sound theory which reflects the mechanisms of behavior, appropriate selection of the necessary geotechnical parameters, and a good knowledge of the applied loadings, together with a measure of good fortune.

INTRODUCTION

In his Rankine Lecture dealing with geotechnical predictions, Lambe (1973) has stated that “The soil engineer may be the master predictor. He must work with incomplete, widely scattering and varying data; he frequently has the opportunity to compare his prediction with the predicted event; and he must usually take responsibility for his prediction”.

Case histories in geotechnical engineering serve a number of useful purposes, one of which is to provide real data against which designers can test their predictions of behaviour. There is ample evidence to indicate that, despite the many advances made in geotechnical engineering and engineering science in the past three decades since Lambe’s Rankine Lecture, the geotechnical designer’s ability to predict behaviour accurately has not increased. The reasons for this apparent lack of improvement are numerous, and perhaps it will always be as difficult to make accurate geotechnical predictions as it is to make predictions of human behaviour.

In an attempt to understand why some predictions are successful and others are not, this paper considers a number of case histories related to deep foundations. An attempt is made to identify factors which may have contributed to predictions which were reasonably successful, and those which may have led to a lack of predictive success. Attention is focused on pile and pile group response to vertical loading.

THE PREDICTION PROCESS

Lambe (1973) has set out a logical “anatomy” of the geotechnical prediction process, which involves the following six steps:

- Determine the field situation;
- Simplify this situation;
- Determine mechanisms of behavior;
- Select a method of analysis and the relevant parameters;
- Manipulate the method and parameters to obtain the prediction;
- Portray the prediction.

In addition to these steps, it is highly desirable to be able to compare predictions with actual measured performance, and hence there are some further desirable steps in the process:

- Instrumentation and monitoring of performance;
- Interpretation and portrayal of the measurements;
- Comparisons between the measurements and the predictions;
- Assessment of the reasons for the success or otherwise of the predictions;
- Improvements to the prediction process employed, on the basis of the lessons learned.

Implicit in Lambe’s philosophy is the fact that lack of success may be due to one or more of the factors listed above, not just the method of analysis. Also implicit is the possibility that a successful prediction may in some cases be the result of cancelling errors, and may represent more good luck than good engineering.

Focht (1994) has re-visited Lambe's philosophical approach, and added a further essential ingredient for prediction success, namely, the application of judgment and intuition to review the predictions and the conclusions derived from them. He has indicated that, in four out of six cases that he examined, a lack of proper judgment was the major cause of poor predictions.

In the following sections, an attempt will be made to present a number of cases in which predictions were either successful or unsuccessful. In each case, an attempt will be made to explain the success or otherwise of the predictions, with respect to the various components of the prediction process. A number of cases will involve "Class A" predictions, as classified by Lambe, that is, predictions made prior to the performance measurements being known. However, some "Class C" cases will also be presented (i.e. those in which the calculations were made after the measurements were obtained and revealed). An honest assessment of such cases can also be instructive in identifying the strengths and weaknesses of the prediction processes employed.

SOME SUCCESSFUL PREDICTIONS

Single Pile Behaviour for the Emirates Project, Dubai

Introduction. The Emirates Project is a twin tower development in Dubai, one of the United Arab Emirates. The towers are triangular in plan form with a face dimension of approximately 50 m to 54 m. The taller Office Tower has 52 floors and rises 355 m above ground level, while the shorter Hotel Tower is 305 m tall. These towers are more than double the height of the nearby World Trade Centre, which was once the tallest building in Dubai. The Office Tower is presently the 8th tallest building in the world, while the Hotel Tower is the 17th tallest. The twin towers are located on a site of approximately 200 000 m², which also incorporates low level retail and parking podium areas.

The foundation system for both towers involved the use of large diameter piles in conjunction with a raft. The opportunity arose to make Class A predictions for a series of single test piles, loaded axially and laterally, as well as predicting the overall settlement of each of the buildings during construction. The single pile predictions will be discussed in this section, while those for the buildings will be presented later. Poulos (2003a) gives more details of this project.

Field Situation. The main geotechnical investigation involved the drilling of 23 boreholes, to a maximum depth of about 80m. It was found that the stratigraphy was relatively uniform across the whole site, so that it was considered adequate to characterize the site with a single geotechnical model. The groundwater level was relatively close to the surface.

Because of the relatively good ground conditions near the surface, it was assessed that a piled raft system would be

appropriate for the foundation of each of the towers. The design of such a foundation system requires information on both the strength and stiffness of the ground. As a consequence, a comprehensive series of in-situ tests was carried out, together with both conventional and advanced laboratory testing. A feature of this latter testing was a series of constant normal stiffness (CNS) direct shear tests to assess the ultimate skin friction of the bored piles and the effects of cyclic loading on the skin friction. The principles of the CNS test are described by Lam and Johnston (1982) and Ooi and Carter (1987).

From the viewpoint of the foundation design, some of the relevant findings from the in-situ and laboratory testing were as follows:

- The site uniformity borehole seismic testing did not reveal any significant variations in seismic velocity, thus indicating that it was unlikely that major fracturing or voids would be present in the areas tested.
- The cemented materials were generally very weak to weak, with unconfined compressive strength (UCS) values ranging between about 0.2 MPa and 4 MPa, with most values lying within the range of 0.5 to 1.5 MPa.
- Cyclic triaxial tests indicated that one of the upper sand deposits had the potential to generate significant excess pore pressures under cyclic loading, and to accumulate permanent deformations under repeated one-way loading. It could therefore be susceptible to earthquake-induced settlements.
- The constant normal stiffness (CNS) shear tests indicated that cyclic loading had the potential to significantly reduce or degrade the skin friction after initial static failure, and that a cyclic stress of 50% of the static resistance could cause failure during cyclic loading, resulting in a very low post-cyclic residual strength.

Figure 1 summarizes the values of Young's modulus obtained from the following tests:

- seismic data (reduced by a factor of 0.2 to account for a strain level appropriate to the foundation);
- resonant column tests (at a strain level of 0.1%);
- laboratory stress path tests;
- unconfined compression tests (at 50% of ultimate stress).

While inevitable scatter exists among the different values, there is a reasonably consistent general pattern of variation of modulus with depth. Figure 1 also shows the profile of modulus adopted for design. Considerable emphasis was placed on the laboratory stress path tests, which, it was felt, reflected realistic stress and strain levels within the various units. The values for the upper two units were obtained from correlations with SPT data.

Figure 2 shows the ultimate static shear resistance derived from the CNS test data, as a function of depth below the surface. With the exception of one sample, all tests showed a maximum shear resistance of at least 500 kPa. The measured values from the CNS tests were within and beyond the range of design values of static skin friction of piles in cemented soils suggested tentatively by Poulos (1988).

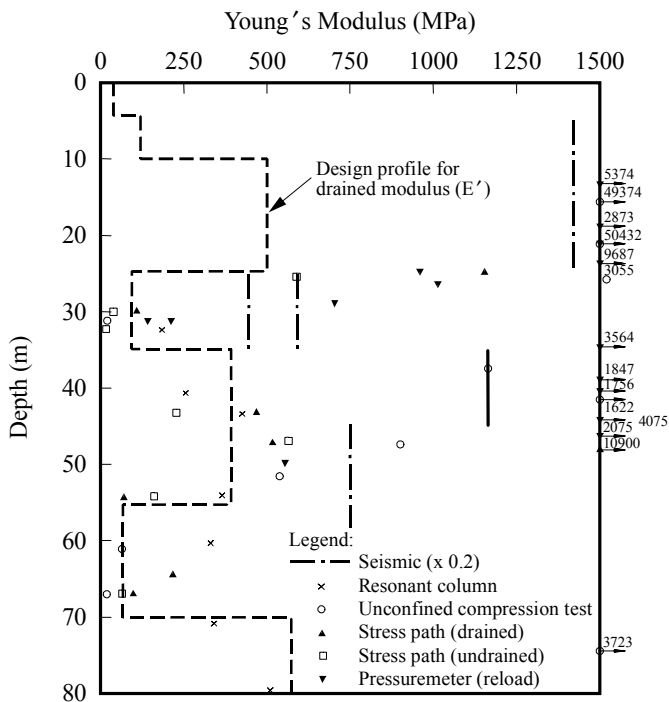

Fig. 1. Emirates project – summary of Young's Modulus values.

Simplification. The geotechnical model for foundation design under static loading conditions was based on the relevant available in-situ and laboratory test data, and is shown in Fig. 3. The ultimate skin friction values were based largely on the CNS data, while the ultimate end bearing values for the piles were assessed on the basis of correlations with UCS data (Reese and O'Neill, 1988) and also previous experience with similar cemented carbonate deposits (Poulos, 1988). The values of Young's modulus were derived from the data summarized in Fig. 3.

Mechanism of Behavior. While the building foundations were piled raft systems, each of the single test piles were subjected to applied head loading. Thus, the mechanism of behavior was straight-forward in this case.

Selection of Method and Parameters, and Manipulation. In order to provide some guidance on the expected behaviour of the piles during the test pile program, "Class A" predictions of the load-deflection response of the test piles were carried out and communicated to the main consultant prior to the commencement of testing. The geotechnical model was similar to that used for design (Fig. 3), with some minor modifications to allow for the specific stratigraphic conditions at the test pile locations, as revealed during installation of the test piles. The following programs were used to make the predictions:

1. Static compression and tension tests – PIES (Poulos, 1989);
2. Cyclic tension test – SCARP (Poulos, 1990).
3. Lateral load test – ERCAP (CPI, 1992).

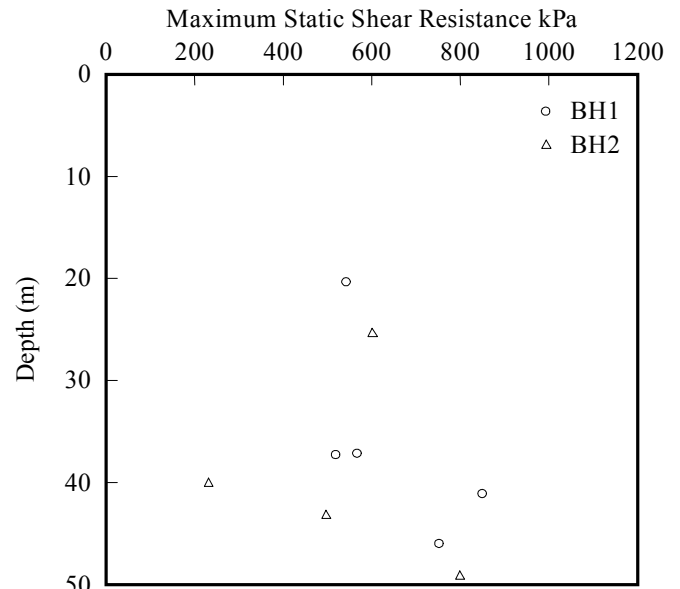

Fig. 2. Summary of ultimate shaft friction from CNS tests.

	E_u MPa	E' MPa	ν'	f_s kPa	f_b MPa	P_u MPa	Unit
0							
0	40	30	0.2	18	0.15	0.1	1
10	125	100	0.2	73	1.5	1.5	2
20	700	500	0.1	200	2.3	2.3	3
30	125	100	0.2	150	1.9	1.9	4
40	500	400	0.2	450	2.7	2.7	5
50							
60	90	80	0.3	200	2.0	2.0	6
70							
80	700	600	0.3	450	2.7	2.7	7

Fig. 3. Geotechnical model adopted for design.

All three programs were capable of incorporating non-linear pile-soil response, and of considering the effects of the reaction piles. The input parameters for the predictions were those used for the design, as shown in Fig. 3. SCARP however required data on

cyclic degradation characteristics for skin friction and end bearing. Some indication on skin friction degradation was available from the CNS test data, but some of the parameters had to be assessed via judgement and previous experience with similar deposits. It was therefore expected that the predictions for the cyclic tension test would be less accurate than for the static tests.

Instrumentation and Monitoring. Figure 4 shows the test setup for the 0.9 m diameter test piles. For the compression tests, the loading was supplied by a series of jacks, while the reaction was provided by 22 anchors drilled into the underlying calcisiltite. The anchors were connected to the test pile via two crowns (a larger one above a smaller unit) located above the jacks and load cells. For the tension tests, the reaction was supplied by a pair of reaction piles 12 m long, with a cross-beam connecting the heads of the test and reaction piles. In the lateral load tests, the test pile was jacked against the adjacent 0.9m diameter compression test pile.

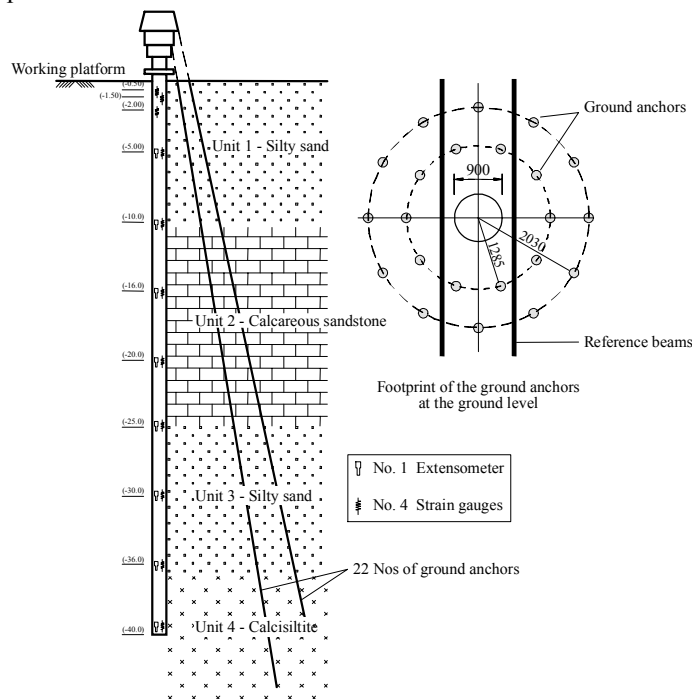

Fig. 4. Setup for compression pile tests.

Four main types of instrumentation were used in the test piles:

- Strain gauges (concrete embedment vibrating wire type) to allow measurement of strains along the pile shafts, and hence estimation of the axial load distribution.
- Rod extensometers, to provide additional information on axial load distribution with depth.
- Inclinometers – the piles for the lateral load tests had a pair of inclinometers, at 180 degrees, to enable measurement of rotation with depth, and hence assessment of lateral displacement with depth.
- Displacement transducers, to measure vertical and lateral displacements.

Comparisons Between Prediction and Performance.

(a) Compression Tests

Comparisons between predicted and measured test pile behaviour were made after the results of the tests were made available. Figure 5 compares the measured and predicted load-settlement curves for Test P3(H), and reveals a fair measure of agreement in the early stages. The predicted settlements exceed the measured values, and the maximum load of 30 MN reached exceeded the estimated ultimate load capacity of about 23 MN. The corresponding comparison for the Office Tower test pile P3(O), revealed excellent agreement, with the predicted ultimate load capacity of 23 MN being exceeded.

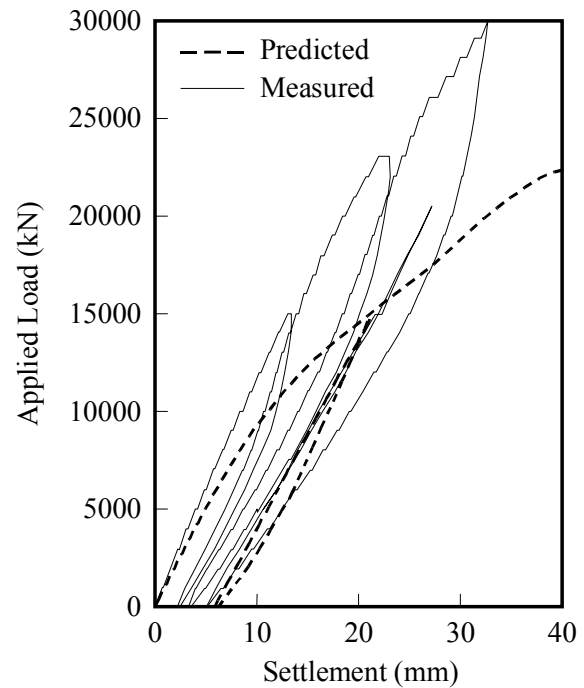

Fig. 5. Predicted and measured load-settlement behaviour for pile P3(H).

Figure 6 shows the measured and predicted distributions of axial load with depth, for two applied load levels. The agreement at 15 MN load is reasonable, but at 23 MN, the measured loads at depth are less than those predicted, indicating that the actual load transfer to the soil (i.e. the ultimate shaft friction) was greater than predicted.

(b) Static Tension Tests

Figure 7 compares the measured and predicted load-displacement curves, and indicated good agreement up to about 2 MN load. At higher loads, the actual displacement exceeded the predicted value, but the maximum load reached of 5.5 MN exceeded the predicted ultimate value of about 4.7 MN. For the Office Tower test pile, a similar measure of agreement was obtained, although the maximum load in that case was about 7.5 MN, because the

test pile had a larger diameter (700mm) than the originally planned 600mm upon which the predictions were based.

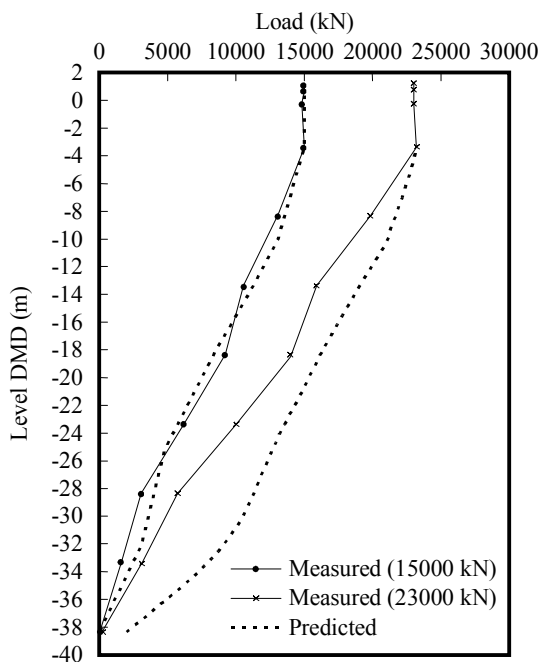

Fig. 6. Predicted and measured axial load distribution for pile P3(H).

Figure 8 shows the values of ultimate skin friction inferred from the axial load distribution measurements, for both the compression and tension tests. Also shown are the design values, and these are in reasonable agreement with the measured values; indeed, the design values appear to be comfortably conservative. It is interesting to note that the design values were substantially larger (by about a factor of 2) than the design values commonly used in the UAE prior to the project. It appears that the CNS tests, which were used as the primary basis for selecting the design values of skin friction, holds great promise as a means of measuring relevant pile skin friction characteristics in the laboratory.

(c) Cyclic Tension Tests

Figure 9 shows the results of the cyclic tension test for the Hotel Tower pile (P2(H)). Four parcels of one-way cyclic load were applied, and for each parcel there was an accumulation of displacement with increasing number of cycles, this accumulation being more pronounced at higher load levels. The predictions from the SCARP analysis are also shown in Fig. 9, and while the predictions at loads less than 1 MN are reasonable, the theory significantly under-estimates the accumulation of displacement at higher load levels. A similar (and limited) level of agreement was obtained for the test on the Office Tower test pile (P2(O)). It had been anticipated that predictions of cyclic response may not be accurate, and this expectation was borne out by the

comparisons. Nevertheless, from a practical viewpoint, the important feature of the cyclic tension tests was that a load of about 50% of the static ultimate load could be applied without the pile failing (i.e. reaching an upward displacement of the order of 5-10% of diameter).

(d) Lateral Load Tests

Figure 10 shows the predicted and measured load-deflection curves for the Hotel Tower test pile. Both the test pile and the reaction pile responses are plotted. The agreement in both cases is reasonably good, although there is a tendency for the predicted deflections to be smaller than the measured values as the load level increases. A similar measure of agreement was found for the Office Tower pile, although the initial prediction had to be modified to allow for the larger as-constructed diameter of the test pile. It should be noted that the predictions took account of the interaction between the test pile and the reaction pile. Had this interaction not been taken into account, the predicted deflections would have been considerably larger than those measured.

Figure 11 shows the predicted and measured deflection profiles along the Hotel test pile, at an applied load of 150 kN. The agreement is generally good, although the measurements indicate a reversal of direction of deflection at about 3.5 m depth, a characteristic which was not predicted.

Assessment of the Predictions. Class A predictions of the performance of the test piles were found to be in good agreement with the measurements. In particular, the values of ultimate skin friction along the pile inferred from the load tests were in good agreement with the values used for design, which were derived from Constant Normal Stiffness (CNS) laboratory tests. The reasons for the success of these predictions may include the following:

- The comprehensive investigation and testing program for the Emirates Project enabled the site to be characterized in a more complete manner than is usually possible with many projects.
- Modern methods of in-situ and laboratory testing were used in conjunction with advanced methods of foundation analysis;
- The mechanisms of behavior were relatively straight-forward.

ESOPT II Prediction Exercise

Introduction. In conjunction with the European Conference on Penetration Testing (ESOPT II) held in Amsterdam in 1982, a case study involving the prediction of the driveability and bearing capacity of a single driven pile was devised. The pile was precast concrete, 0.25m square in section, and approximately 15m long, and was driven at the site with a Delmag D12 diesel hammer.

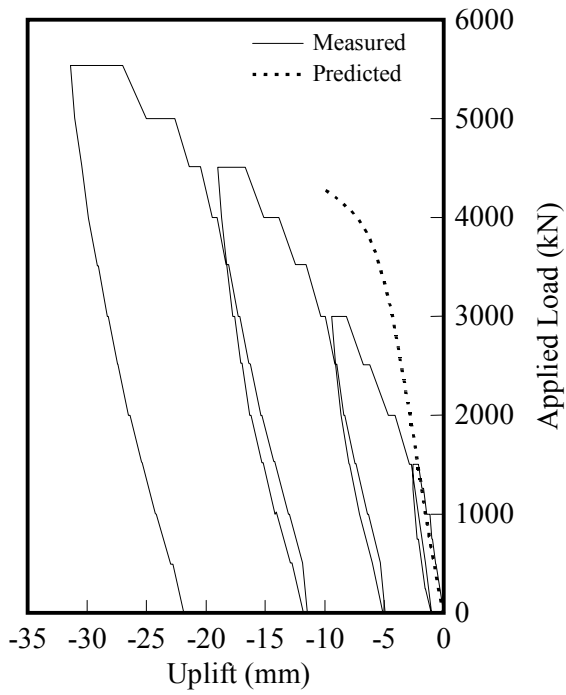

Fig. 7. Predicted and measured load-uplift behaviour for tension test on pile P1(H).

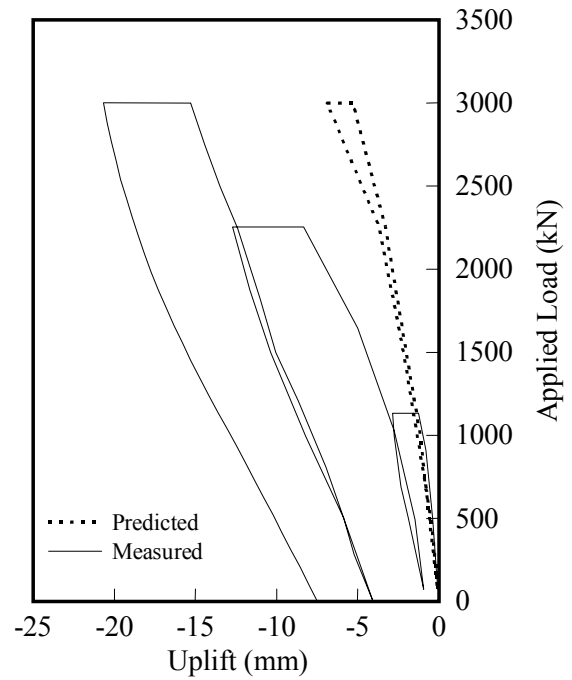

Fig. 9. Measured and predicted load-uplift behaviour for cyclic uplift test- pile P2(H).

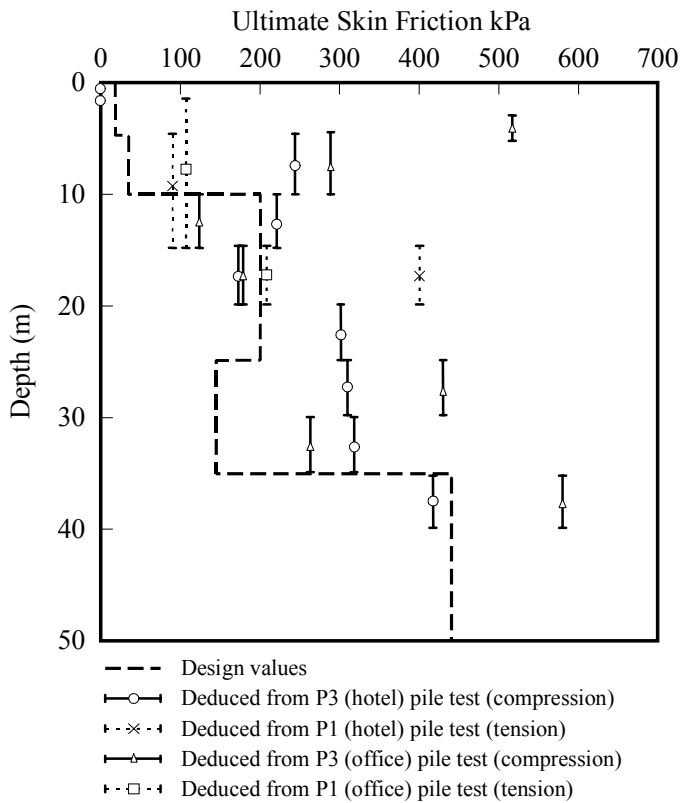

Fig. 8. Ultimate skin friction values – design values and values derived from load tests.

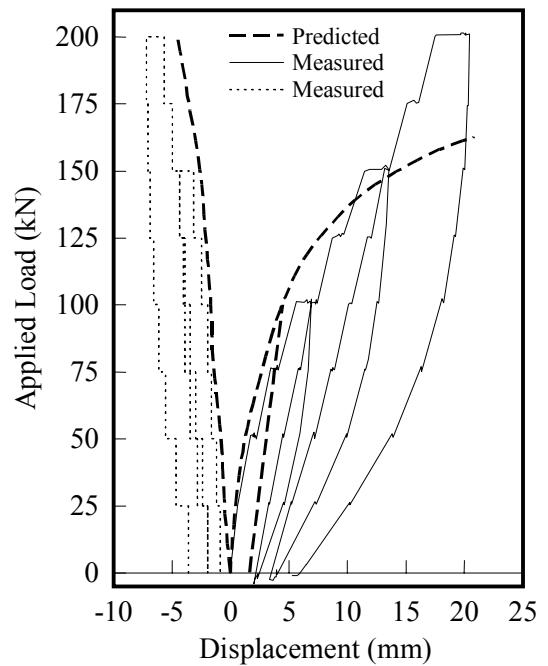

Fig. 10. Measured and predicted lateral load versus deflection – pile P2(H).

Field Situation, Simplification and Mechanisms. Figure 12 summarizes the geotechnical data available at the time of the prediction. The upper 10-12 m was loose and /or soft, and the pile was to be driven to an underlying dense sand layer. Cone penetration and SPT data were available for the site, but the author chose to use the CPT data. The stratigraphy and the CPT profile were simplified as shown in Fig. 12

As with the Emirates case, the mechanisms of behavior were straight-forward, involving only pile-soil interaction under vertical loading and under dynamic impact loading during installation.

Selection of Method of Analysis and Parameters, and Manipulation. Three aspects of behavior were predicted:

- Ultimate axial capacity
- Load-settlement behavior
- Blowcounts during installation.

The ultimate axial capacity was estimated by summation of the base and shaft resistances. The base resistance was taken to be equal to the average cone resistance within a distance of 25 cm above the pile tip, and 75 cm below the tip. The ultimate shaft resistance was computed from the measured local friction values obtained from CPT tests. A number of other alternative approaches were tested prior to the adoption of this method. The resistance within the top 1m of the pile shaft was ignored. Some approximate allowance was made for the reduction in capacity due to the repeated loading during the test, using (somewhat inappropriately) data for a clay from the Sydney region in Australia.

The load-settlement behavior was predicted using a simplified boundary element analysis. Allowance was made for slip at the pile-soil interface, using the ultimate shaft friction values computed from the sleeve friction data. The soil modulus along and beneath the shaft was estimated from correlations with the cone resistance q_c , using values of $7.5q_c$ for sand, $10q_c$ for clay and clayey sand, and $15q_c$ for peat. Again, allowance was made for the possible effects of repeated loading during the test, although this was in fact found to be small.

The behavior during driving, i.e. the blowcount at various penetration depths, was estimated from a wave equation analysis. The ultimate capacity versus depth was calculated, as described above, and it was assumed that the resistance during driving would equal the ultimate static resistance of the pile. A number of assumptions were made in the wave equation analysis, including the quake, damping, hammer efficiency (taken as 75%), and the capblock and cushion stiffnesses and coefficients of restitution. Most of these were chosen on the basis of published information available at the time.

Comparisons Between Predicted and Measured Behavior. To the author's knowledge, only the pile head load-settlement behavior

was measured, as the focus was on ultimate capacity. Figure 13 shows the predicted and measured load-settlement curves. The agreement is fair, with the predicted load-settlement curve being conservative at typical working loads, and over-predicting the ultimate capacity by about 20%. The absence of detailed load distribution data precludes an explanation for the discrepancy, but it is suspected that the values of shaft friction derived directly from the sleeve friction data were too large. The modulus values adopted for the soil appear to have been comfortably conservative.

Figure 14 compares the predicted and measured blowcounts. The predicted blowcounts are somewhat higher than those measured, although the overall agreement is not unreasonable. At least part of the reason for the larger predicted blowcounts is the fact that the ultimate pile capacity was almost certainly over-predicted at intermediate elevations, as well as at the final penetration.

Assessment of Predictions. The overall agreement between prediction and measurement in this case was reasonable, if not close. This may be attributed to the relative simplicity of the mechanisms involved, a reasonable characterization of the site, the accumulated published experience with local soil conditions, and some measure of good fortune in selecting soil modulus values based on the CPT data. It is also believed that the calculation methods employed were reasonable, and the author would still use these methods today if a similar prediction were to be made.

The discrepancy in ultimate load estimates can be attributed to the use of the uncorrected sleeve resistance results. It is now generally accepted that some correction (usually involving a reduction) needs to be made to these values to obtain relevant values for a pile.

Pile Group Tests of Kaino and Aoki (1985)

Introduction. This case involved a "Class C" prediction of the settlement of a relatively small pile group, in that the calculations were carried out when there was full knowledge of the monitoring results. Nevertheless, it does demonstrate some useful points in relation to factors which aid success in pile performance prediction.

Field Situation and Simplification. The available geotechnical data and the pile group configuration are shown in Fig. 15 (see Poulos, 1993). The soil profile consisted of layers of alluvial clay underlain by interbedded sand and clay layers. The piles were 24 m long and 1 m in diameter, and were constructed using the reverse circulation method.

Mechanism. The mechanism of behavior was seen to be relatively straight-forward, and involved pile-soil-pile interaction within a 5-pile group.

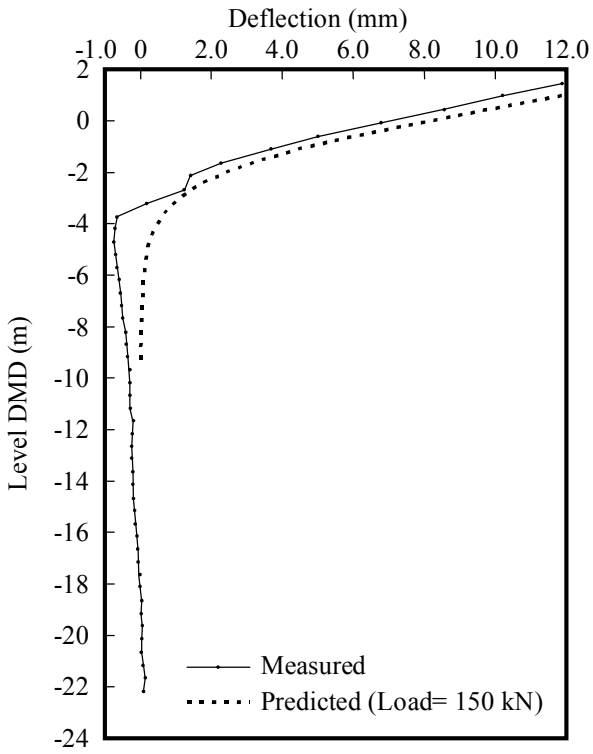

Fig. 11. Measured and predicted deflection distributions – pile P2(H).

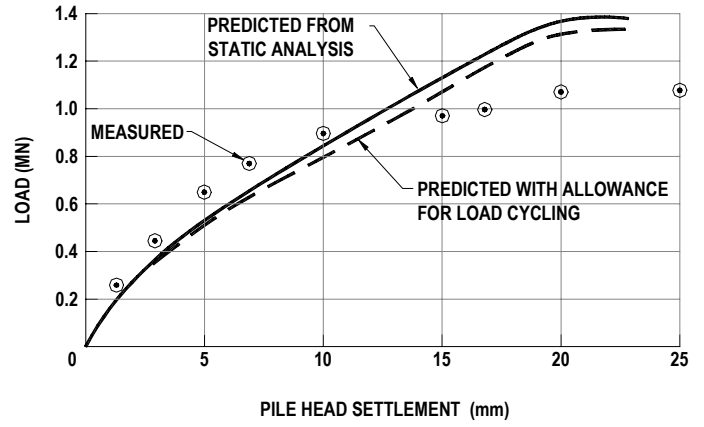

Fig. 13. Predicted load-settlement behaviour for pile head.

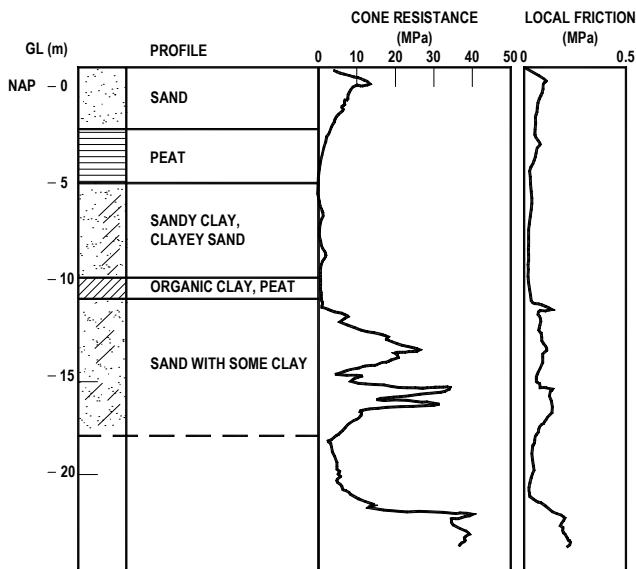

Fig. 12. Soil profile and cone penetration data for ESOPT II case.

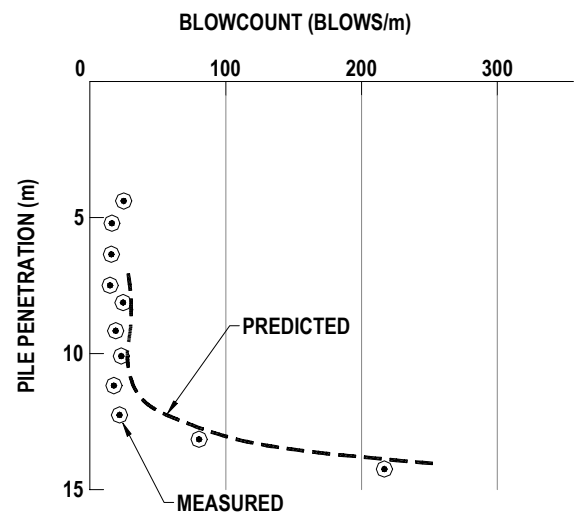

Fig. 14. Predicted blowcount during driving.

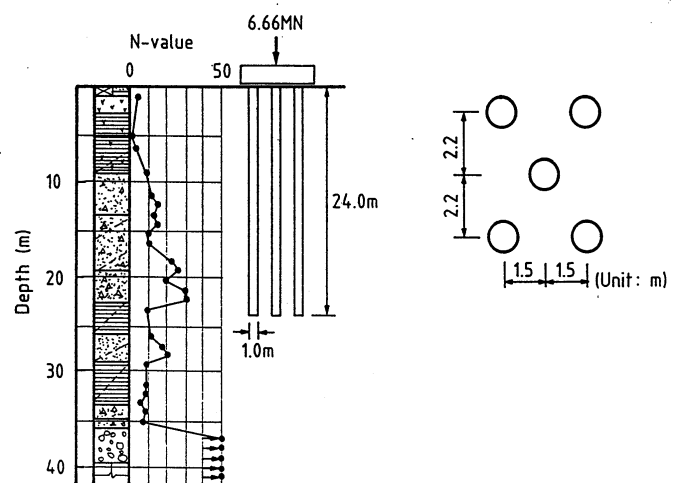

Fig. 15. Soil profile for case history of Kaino & Aoki (1985).

Method of Analysis and Selection of Parameters. The interaction factor method was used to analyze the settlement and load distribution within the group, using the computer program DEFPIG. Each pile was divided into 10 shaft elements and a single base element, and values of Young's modulus of the soil were selected on the basis of correlations with the SPT data. The modulus values ranged from about 12 MPa near the surface to about 74 MPa along the lower parts of the pile, while the value at the pile tip was taken as 38 MPa. A rigid base was assumed to be present at a depth of 35 m below the surface. For the calculation of interaction factors, the ratio of small-strain to near-pile soil modulus was taken to be 3.

Results and Comparisons with Measurements. The computed group settlement under a working load of 6.66 MN was 3.9 mm. This agreed remarkably well with the measured value of 3.8 mm. In addition, the distributions of axial load along the centre and corner piles were computed and compared with the measured distributions. The comparison is shown in Fig. 16 and reveals very good agreement.

Assessment of Predictions. The predictions of settlement and load distribution were in good agreement with the measurements, and this agreement may be attributed to the allowance for the stiffer soil between the piles in computing interaction factors, and a possibly fortuitous selection of Young's modulus values for the soil along and below the piles. Because the piles were relatively closely spaced, and because the number of piles was small, the possible inaccuracies in the theoretical interaction factors for large spacings did not play a role in these predictions.

SOME UNSUCCESSFUL PREDICTIONS

Emirates Project. Piled Raft Foundation Behavior

Field Situation and Simplification. The ground conditions have already been described in relation to the single pile Class A predictions. The same geotechnical model was used for the prediction of the settlement of the buildings themselves.

In the final design, the piles were primarily 1.2 m diameter, and extended 40 or 45 m below the base of the raft. In general, the piles were located directly below 4.5 m deep walls which spanned between the raft and the Level 1 floor slab. These walls acted as "webs" which forced the raft and Level 1 slab to act as the flanges of a deep box structure. This deep box structure created a relatively stiff base to the tower superstructure, although the raft itself was only 1.5 m thick. Figures 17 and 18 show the foundation layout for the two towers, with the piles being generally located beneath the load bearing walls.

Mechanisms. The mechanisms of behaviour for the foundation involved pile-soil-raft interaction, as well as interaction with the

superstructure. The latter was not taken into account, but the geotechnical aspects of pile-soil-raft interaction were incorporated into the analysis, as described below.

Analysis Methods, Selection of Parameters, and Manipulation.

Conventional pile capacity analyses were used to assess the ultimate geotechnical capacity of the piles and raft. For the piles, this capacity was taken as the sum of the shaft and base capacities. For the raft, account was taken of the layering of the geotechnical profile, and the large size of the foundation, and a value of 2.0 MPa was adopted for the ultimate bearing capacity. In these conventional analyses, it was assumed that the portion of the raft effective in providing additional bearing capacity had a diameter of 3.6m (3 pile diameters) around each pile.

In addition to the conventional analyses, more complete analyses of the foundation system were undertaken with the computer program GARP (Poulos, 1994). GARP (Geotechnical Analysis of Raft with Piles) utilizes a simplified boundary element analysis to compute the behaviour of a rectangular piled raft when subjected to applied vertical loading, moment loading, and free-field vertical soil movements. The raft is represented by an elastic plate, the soil is modelled as a layered elastic continuum, and the piles are represented by hyperbolic springs which can interact with each other and with the raft. Beneath the raft, limiting values of contact pressure in compression and tension can be specified, so that some allowance can be made for non-linear raft behaviour. In addition to GARP, the program DEFPIG (Poulos and Davis, 1980) was used for the pile stiffness values and pile-pile interaction factors, and for computing the lateral response of the piles.

For the analysis of settlements under the design loads, the same values of Young's modulus were used as for the single piles, whose behavior had been quite well-predicted. For the non-linear GARP analysis, the unfactored values of estimated raft bearing capacity and ultimate pile load capacity were used.

Comparison Between Predictions and Measurements. Table 1 summarizes the computed maximum settlement and angular rotation under serviceability loading conditions. These computed values were relatively large, but were nevertheless acceptable for the project. It was found that the settlements showed a "dishing" pattern, with the settlements near the centre being significantly greater than those near the edge of the foundation.

Table 1. Computed Maximum Settlement and Angular Rotation Serviceability Limit State

Tower	Max. Settlement mm	Max. Angular Rotation
Office	134	1/384
Hotel	138	1/378

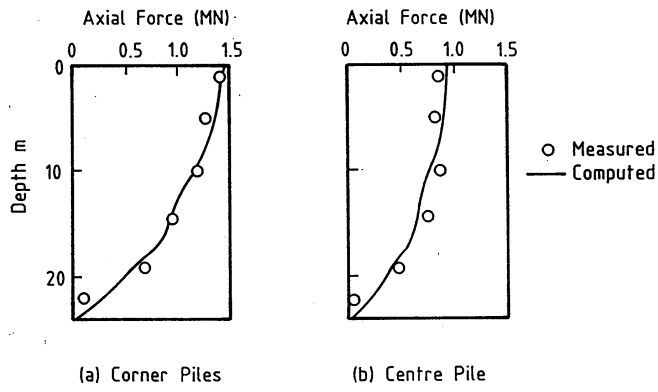

Fig. 16. Measured and computed load distributions along piles.

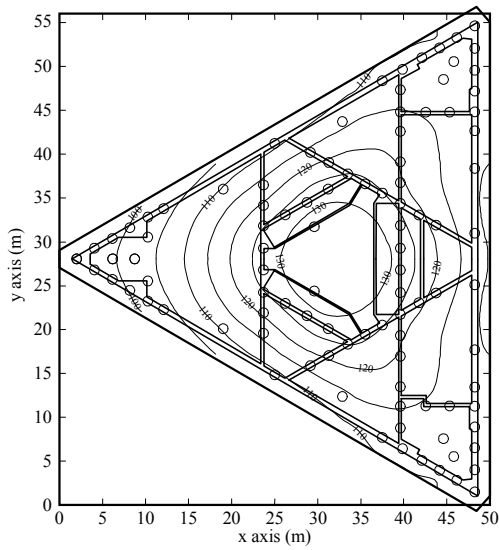

Fig. 17. Foundation layout and computed settlement contours for Office Tower.

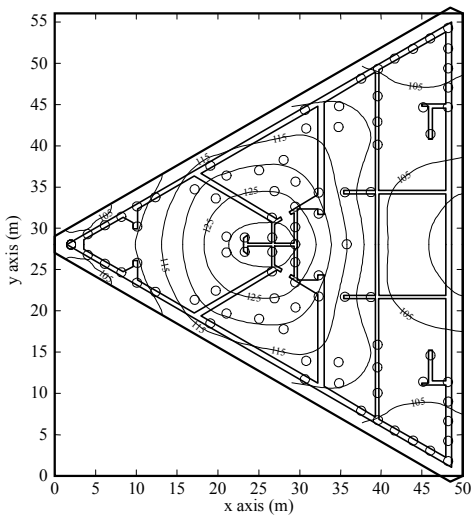

Fig. 18. Foundation layout and computed settlement contours for Hotel Tower.

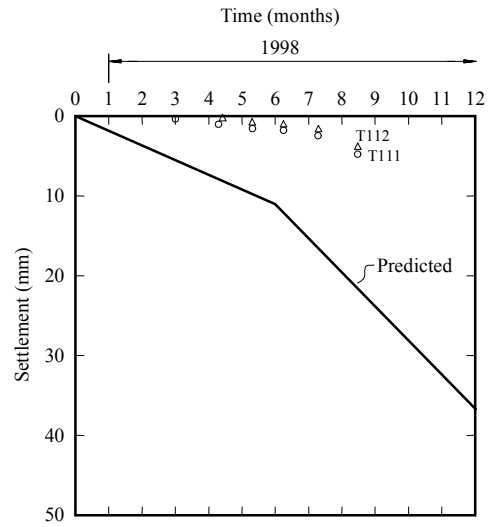

Fig. 19. Predicted and measured settlement vs time – Office Tower.

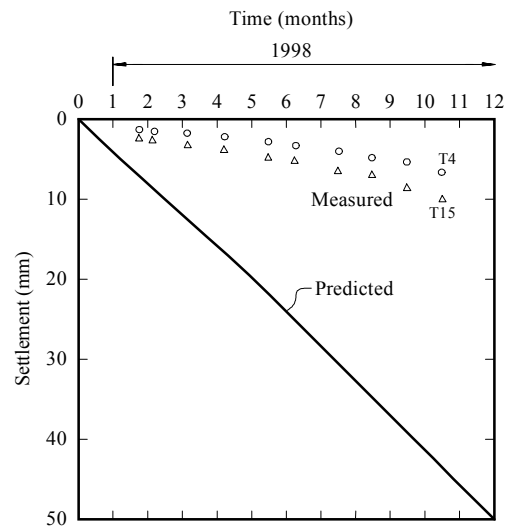

Fig. 20. Predicted and measured settlement vs time – Hotel Tower.

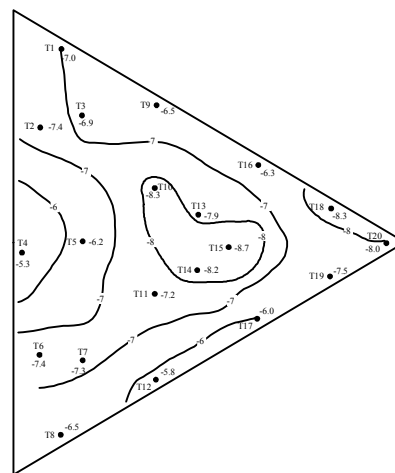

Fig. 21. Measured settlement contours – Hotel Tower.

The generally good agreement between measured and predicted performance of the test piles gave rise to expectations of similar levels of agreement for the entire tower structure foundations. Unfortunately, this was not the case. Measurements were available only for a limited period during the construction process, and these are compared with the predicted time-settlement relationships in Figures 19 and 20, for typical points within the Office Tower and the Hotel Tower respectively. The time-settlement predictions were based on the predicted final settlement, an assumed rate of construction, and a rate of settlement computed from three-dimensional consolidation theory.

Figures 19 and 20 show, that for both towers, the actual measured settlements were significantly smaller than those predicted, being only about 25% of the predicted values after 10-12 months. Figure 21 shows the contours of measured settlement at a particular time during construction for the hotel tower. Although the magnitude of the measured settlements was far smaller than predicted, the distribution was similar to that predicted. Thus, despite the considerable thickness of the raft and the apparent stiffness of the structure, the foundation experienced a “dishing” distribution of settlement more characteristic of a flexible foundation. It is interesting to note that similar “dishing” has been measured on some other high-rise structures on piled raft foundations, particularly the Messe Turm Tower in Frankfurt, Germany (Sommer, 1993; Franke et al, 1994).

Assessment of Predictions - Possible Reasons for Discrepancies.

The disappointing lack of agreement between measured and predicted settlement of the towers prompted a “post-mortem” investigation of possible reasons for the poor predictions. At least four reasons were suggested:

1. Some settlements may have occurred prior to the commencement of measurements;
2. The assumed time-load pattern may have differed from that assumed;
3. The rate of consolidation may have been much slower than predicted;
4. The interaction effects among the piles within the piled raft foundation may have been over-estimated.

Of these, based on the information available during construction, the first two did not seem to be likely, and the last was considered to be the most likely cause. Calculations were therefore carried out to assess the sensitivity of the predicted settlements to the assumptions made in deriving interaction factors for the piled raft analysis with GARP. In deriving the interaction factors originally used, it had been assumed that the soil or rock between the piles had the same stiffness as that around the pile, and that the rock below the pile tips had a constant stiffness for a considerable depth. In reality, the ground between the piles is likely to be stiffer than near the piles, because of the lower levels of strain, and the rock below the pile tips is likely to increase significantly with depth, both because of the increasing level of overburden stress and the decreasing level of strain. The program DEFPIG was therefore used to compute the interaction factors for a series of alternative (but credible)

assumptions regarding the distribution of stiffness both radially and with depth. The ratio of the soil modulus between the piles to that near the piles was increased to 5, while the modulus of the material below the pile tips was increased from the original 70 MPa to 600 MPa (the value assessed for the rock at depth). The various cases are summarized in Table 2.

Figure 22 shows the computed relationships between interaction factor and spacing for a variety of parameter assumptions. It can be seen that the original interaction curve used for the predictions lies considerably above those for more realistic assumptions. Since the foundations analyzed contained many piles, the potential for over-prediction of settlements is considerable, since small inaccuracies in the interaction factors can translate to large errors in the predicted group settlement (for example, Poulos, 1993).

Revised settlement calculations, on the basis of these interaction factors, gave the results shown in Table 2. The interaction factors used clearly have a great influence on the predicted foundation settlements, although they have almost no effect on the load sharing between the raft and the piles. The maximum settlement, for Case 4, is reduced to 29% of the value originally predicted, while the minimum settlement is only 25% of the original value. If this case was used for the calculation of the settlements during construction, the settlement at Point T15 would be about 12 mm, which is in much closer agreement with the measured value of about 10 mm than the original predictions.

Curve No.	Modulus of Layer below MPa	Modulus of Soil between Piles to Near-Pile Values
1	90	1.0
2	90	5.0
3	200	5.0
4	700	5.0
5	700	1.0

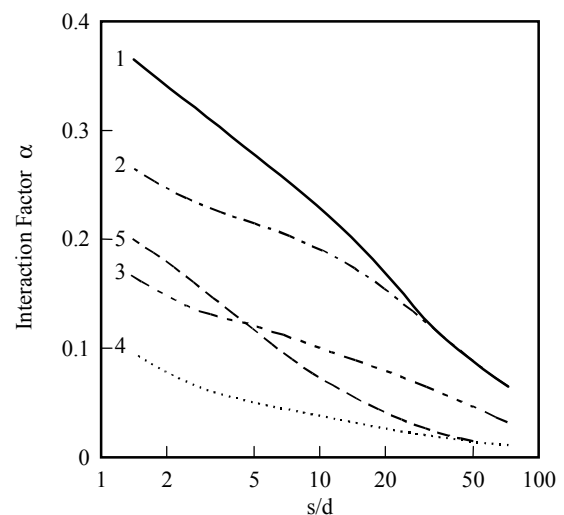

Fig. 22. Sensitivity of computed interaction factors to analysis assumptions.

The importance of proper assessment of the geotechnical model in order to compute the effects of group interaction has again been emphasized by this case history. In addition, there was probably an inadequate appreciation of the real mechanisms of pile-soil-raft behavior, and the potential problems of applying interaction factors to large pile groups, at the time of the predictions. In addition, in contrast to the single pile tests, the calculations were done for the purposes of design, rather than prediction, and consequently tended to be conservative.

Table 2. Summary of Revised Calculations for Hotel Tower

Case	Modulus below 53 m MPa	Ratio of max. to near-pile modulus	Max. Settlement mm	Min. Settlement mm	% Load on Piles
Original calcul- ations	80	1	138	91	93
Case 2	80	5	122	85	93
Case 3	200	5	74	50	92
Case 4	600	5	40	23	92
Case 5	600	1	58	32	92

Large Pile Group Supporting Grain Terminal

Introduction. This case is again a Class C prediction for a published case history (Goosens and van Impe, 1991). In this project, a block of 40 cylindrical reinforced concrete silos, each 52 m high and 8 m in diameter, covered a rectangular area 34 m by 84 m. A 75 m high tower block was also constructed adjacent to the silos.

Field Situation and Simplification. The silos were built on a 1.2 m thick foundation slab which was supported by a total of 697 driven cast-in-situ reinforced concrete piles. The pile length was 13.4 m and the shaft diameter was 0.52 m. The diameter of the expanded base was variable, but was judged to have an average value of 0.8 m. The average pile load under operating conditions was estimated to be about 1.3 MN.

A simplified geotechnical profile near the centre of the site is shown in Fig. 23, together with average values of the static cone resistance.

Mechanisms. The mechanisms involved in this case involve pile-soil-pile interaction among a very large number of piles. This mechanism dominated the author's original thinking and dictated the method of analysis chosen at that time. If one views the foundation system to scale, the piles, together with the soil between them, appear to simply act as a deeper "raft" or mat foundation. There may have been some measure of interaction

between the foundation and the structure, but this was ignored in the calculations. Thus, there was an element of flawed judgment by the author in this case.

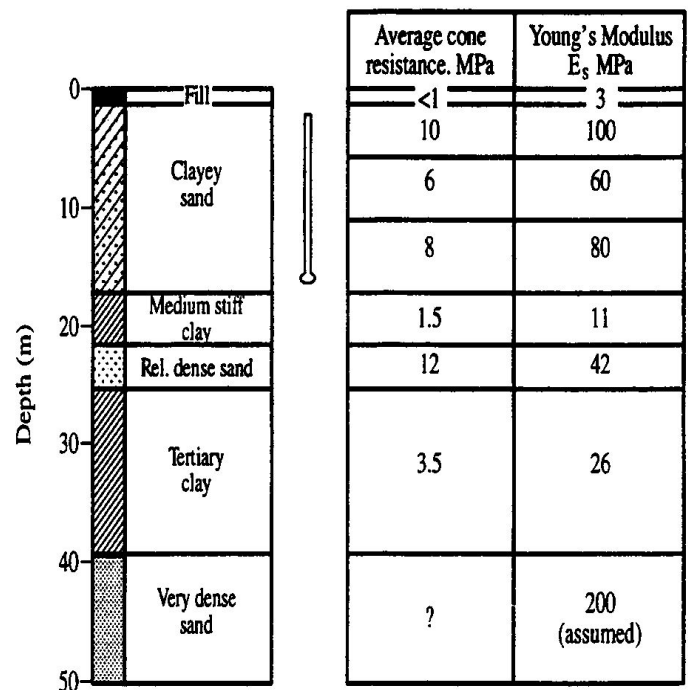

Fig. 23. Geotechnical profile and model for case of Goosens and van Impe (1991).

Method of Analysis and Selection of Parameters. The program DEFPIG was selected for the original analysis. Values of soil Young's modulus were assessed from the cone resistance values, and are shown in Fig. 23. The ratio of modulus to cone resistance ranged from 3.5 in the dense sand to 10 in the upper clayey sand layers. The ratio of small-strain to near-pile Young's modulus of the soil was taken to be 3.

Because of the large number of piles, it was not possible to directly analyze all 697 piles. Therefore, calculations were carried out for groups of 16 and 25 piles, and the results were extrapolated for 697 piles. It was found that the settlement ratio increased with the number of piles to the power 0.743, giving a settlement ratio of about 130. The computed single pile settlement under the average load of 1.3 MN was 5.0 mm, which was larger than the measured settlement of 2.8 mm from two pile load tests. A correction was made to the calculated group settlement to allow for the fact that the measured settlements were along the outer edge of the silo. Thus, the computed maximum settlement of the outer edge was 440 mm.

Comparisons with Measured Values. The measured settlements along the edge of the silo foundation are shown in Fig. 24. The

maximum settlement is 185 mm, which is significantly less than the computed value from DEFPIG of 440 mm. In addition to the DEFPIG analysis, an equivalent raft analysis was carried out, and the computed settlements from this simple analysis gave remarkably good agreement with the measured values, as shown in Fig. 24.

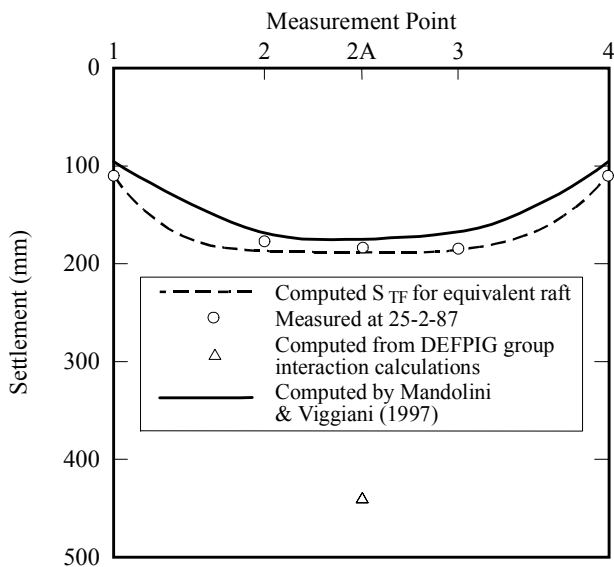

Fig. 24. Computed and measured settlements along edge of silo.

Assessment of Predictions – Possible reasons for Discrepancies.

The settlement computed from DEFPIG severely over-predicted the settlement. The contributing factors to this over-prediction may have been:

- The use of theoretical interaction factors for analyzing a very large group of piles. Despite taking account of the stiffer soil between the piles, it was not possible to account for the effects of intervening piles themselves in reducing interaction between two widely-spaced piles;
- The extrapolation process employed was probably flawed, as it was based on only relatively small groups of piles;
- The computed single pile settlement was larger than the measured value. Had the settlement ratio been applied to this measured settlement (and correction made for the edge location of the measurements), the computed settlement would have been 246 mm, still larger than the measured, but much more respectably so;
- The computed settlement ratio was applied to the whole single pile settlement, whereas it may be argued that it should be applied only to the linear elastic component of the settlement. When the problem was re-visited by Mandolini and Viggiani (1997), using the latter approach, they obtained excellent agreement with the measurements.

It would therefore appear that the poor predictions were caused by a combination of conservative Young's modulus values for

the soil, an inappropriate extrapolation of the results for smaller pile groups, and the application of the settlement ratio to both the elastic and non-elastic components of the single pile settlement. The fact that the settlement computed from the equivalent raft method was in good agreement with the measurements suggests that the chosen Young's modulus values were perhaps more relevant to a shallow foundation than to a pile foundation.

CONCLUSIONS

After reviewing the various case histories discussed in this paper, there appear to be a number of common characteristics in both the successful and the unsuccessful predictions. The successful predictions were characterized by the following:

1. A relatively simple and well-understood mechanism.
2. Adequate ground characterization.
3. Appropriate selection of the geotechnical parameters.
4. The use of reasonably sound methods of calculation, neither over-simple nor over-complex.

In contrast, the unsuccessful predictions had the following characteristics:

1. The mechanisms of behavior were more complex and were not fully accounted for in the calculations.
2. The ground conditions may not have been taken fully into account; while this was not a major factor in the cases considered here, there are several other cases in which improper characterization can lead to poor predictions (see, for example, Poulos, 2003b).
3. Thus, the analysis method did not reflect all the important aspects of reality.
4. The choice of geotechnical parameters was questionable.

They may also have suffered to some extent from a lack of appropriate judgment and intuition.

While stoutly acknowledging the great value of comparing prediction and actual performance, Lambe (1973) pointed out that field cases rarely permit a conclusive evaluation of any predictive technique, because it is unusual to find a case in which the field situation and the mechanisms involved have been fully identified, and because there is almost certainly considerable judgment exercised by the predictor at various stages in the prediction. Despite these misgivings, it is clear that lessons will continue to be learned from properly executed and interpreted case histories involving piles and pile groups. The more detailed the field measurements are, the more demanding will be the task of the predictor to make a successful prediction. For example, it is more difficult to make good predictions of load – settlement behaviour, load distribution among the piles in the group, and the detailed distribution of load along each pile, than it is simply to make a prediction of the settlement at the working load. Thus, in future cases in which monitoring is to be carried out, steps should be taken to measure as many aspects of behaviour as possible. In this way, it will become easier to distinguish between a fortuitously successful prediction and one that is successful because the mechanisms, analysis and geotechnical parameters

have been selected appropriately, and manipulated and interpreted correctly.

ACKNOWLEDGEMENT

The author is grateful to Dr. T. William Lambe for his early encouragement of the author to consider the vagaries and dubious rewards of making "Class A" geotechnical predictions.

REFERENCES

- CPI [1992]. ERCAP Users Manual, Coffey Partners International, Sydney.
- Franke, E., Lutz, B. and El-Mossalamy, Y. [1994]. "Measurements and Numerical Modelling of High-Rise Building on Frankfurt Clay". ASCE Spec. Pub. No. 40, 2:1325-1336.
- Focht, J.A. [1994] "Lessons Learned from Missed Predictions". *Jnl. Geot. Eng.*, 120(10): 1653-1683.
- Goosens, D. & van Impe, W.F. [1991]. "Long term settlements of a pile group foundation in sand, overlying a clayey layer". *Proc. 10th Eur. Conf. Soil Mechs. Found. Eng.*, Florence, 1: 425-428.
- Kaino, T. and Aoki, H. [1985]. "Vertical load test of cast-in-place concrete pile group (1st Report). Rep. of Struct. Des. Office of JNR, No. 84: 19-23 (in Japanese).
- Lam, T.S.K. and Johnston, I.W. [1982]. "A Constant Normal Stiffness Direct Shear Machine". *Proc. 7th S.E. Asian Conf. on Soil Eng.*, Hong Kong, 805-820.
- Lambe, T.W. [1973]. "Predictions in soil engineering". 13th Rankine Lecture, *Geotechnique*, 23(2): 149-202.
- Mandolini, A. and Viggiani, C. [1997]. "Settlement of piled foundations". *Geotechnique*, 47(4): 791-816.
- Ooi, L.H. and Carter, J.P. [1987]. "A Constant Normal Stiffness Direct Shear Device for Static and Cyclic Loading". *Geot. Testing Jnl.*, ASTM, 10:3-12.
- Poulos, H.G. [1988]. "The Mechanics of Calcareous Sediments". John Jaeger Memorial Lecture, Aust. Geomechanics, Spec. Edition, 8-41.
- Poulos, H.G. [1989]. "Pile behaviour – theory and application". 29th Rankine Lecture, *Geotechnique*, 39(3): 365-415.
- Poulos, H.G. [1993]. "*Settlement prediction for bored piles and pile groups*". Deep Foundations on Bored and Auger Piles, van Impe (Ed), Balkema, Rotterdam, 103-117.

Poulos, H.G. [1994]. "An Approximate Analysis of Pile-Raft Interaction". *Int. Jnl. Num. Anal. Meths, in Geomechs.*, 18: 73-92.

Poulos, H.G. [2003a]. "Pile Performance Prediction for Emirates Project, Dubai". *Soil and Rock America, Proc. Pan-American Conf. SMGE*, Boston.

Poulos, H.G. [2003b]. "*The Significance of Ground Characterization for Foundation Deformation Prediction*". Chin Funbg Kee Lecture, *Geotechnical Eng.*, Ed. K.K. Ho and K.S. Li, Balkema, Rotterdam, 3: 125-145.

Poulos, H.G. and Davis, E.H. [1980]. "*Pile foundation analysis and design*". John Wiley, New York.

Reese, L.C. and O'Neill, M.W. [1988]. "Drilled Shafts: Construction Procedures and Design Methods". Pub. No. FHWA-H1-88-042, US Dept. Transportation.

Sommer, H. [1993]. "Development of Locked Stresses and Negative Shaft Resistance at the Piled Raft Foundation in Messeturm, Frankfurt Main". *Deep Foundations on Bored and Auger Piles*, BAPII, Ed. W.F. van Impe, Balkema, Rotterdam, 347-349.